



US00D873185S

(12) **United States Design Patent**
Hall

(10) **Patent No.:** **US D873,185 S**

(45) **Date of Patent:** **** Jan. 21, 2020**

- (54) **FRONT AUTOMOBILE GRILLE**
- (71) Applicant: **Stephen R. Hall**, Draper, UT (US)
- (72) Inventor: **Stephen R. Hall**, Draper, UT (US)
- (73) Assignee: **Hall Labs LLC**, Provo, UT (US)
- (**) Term: **15 Years**
- (21) Appl. No.: **29/628,753**
- (22) Filed: **Dec. 7, 2017**
- (51) **LOC (12) Cl.** **12-16**
- (52) **U.S. Cl.**
USPC **D12/163**
- (58) **Field of Classification Search**
USPC D12/86, 90-92, 98, 163, 169, 196, 216
CPC ... B60R 19/50; B60R 19/52; B60R 2019/525;
B60K 11/08; B62B 9/16
See application file for complete search history.

2017/0320525 A1* 11/2017 Hall B60R 19/52
 2017/0334259 A1* 11/2017 Hall B60G 3/06
 2018/0086163 A1* 3/2018 Hall B60G 3/20
 2018/0111413 A1* 4/2018 Hall B60B 3/085

(Continued)

OTHER PUBLICATIONS

<https://vanderhallusa.com/3-wheel-car/> Sep. 18, 2017 (Year: 2017).*

(Continued)

Primary Examiner — Leanne Was-Englehart

(57) **CLAIM**

The ornamental design for a front automobile grille, as shown and described.

DESCRIPTION

FIG. 1 is a front elevation view of a front automobile grille showing our new design;
 FIG. 2 is a front and left-side perspective view thereof;
 FIG. 3 is a front left-side perspective view showing where the closeup for FIG. 4 is located;
 FIG. 4 is a close-up of the front and left-side perspective view thereof;
 FIG. 5 is a front and right-side perspective view thereof;
 FIG. 6 shows where the closeup for FIG. 7 is located;
 FIG. 7 is a close-up of the front and right-side perspective view thereof.
 FIG. 8 shows where the closeup for FIG. 9 is located;
 FIG. 9 is a close-up of a bottom and front left-side perspective view thereof;
 FIG. 10 shows where the closeup for FIG. 11 is located; and,
 FIG. 11 is a closeup of a bottom and front right-side perspective view thereof.
 The evenly spaced broken lines depict portions of the front automobile grille that form no part of the claimed design. The dot-dashed broken lines depict the limits of the enlarged view and form no part of the claimed design.

(56) **References Cited**

U.S. PATENT DOCUMENTS

| | | | |
|-------------------|---------|---------------|-------------------------|
| D81,795 S * | 8/1930 | Irving et al. | D12/165 |
| 2,033,376 A * | 3/1936 | Hanson | B60R 19/52 52/662 |
| 2,044,610 A * | 6/1936 | Herreshoff | B62D 25/105 180/54.1 |
| 2,073,581 A * | 3/1937 | Morrison | B60R 19/52 180/69.2 |
| D185,791 S * | 8/1959 | Le Bron | D12/163 |
| D442,517 S * | 5/2001 | Hoogenraad | D12/16 |
| D504,849 S * | 5/2005 | Pfeiffer | D12/163 |
| D541,711 S * | 5/2007 | Golden | D12/169 |
| D620,534 S * | 7/2010 | Ramaciotti | D12/92 |
| D683,267 S * | 5/2013 | Cook | D12/92 |
| 9,643,656 B1 * | 5/2017 | Hall | B62D 25/12 |
| 9,919,589 B1 * | 3/2018 | Hall | B60J 7/106 |
| 10,112,652 B2 * | 10/2018 | Hall | B62D 21/152 |
| 2017/0274939 A1 * | 9/2017 | Hall | B62D 27/023 |

1 Claim, 11 Drawing Sheets

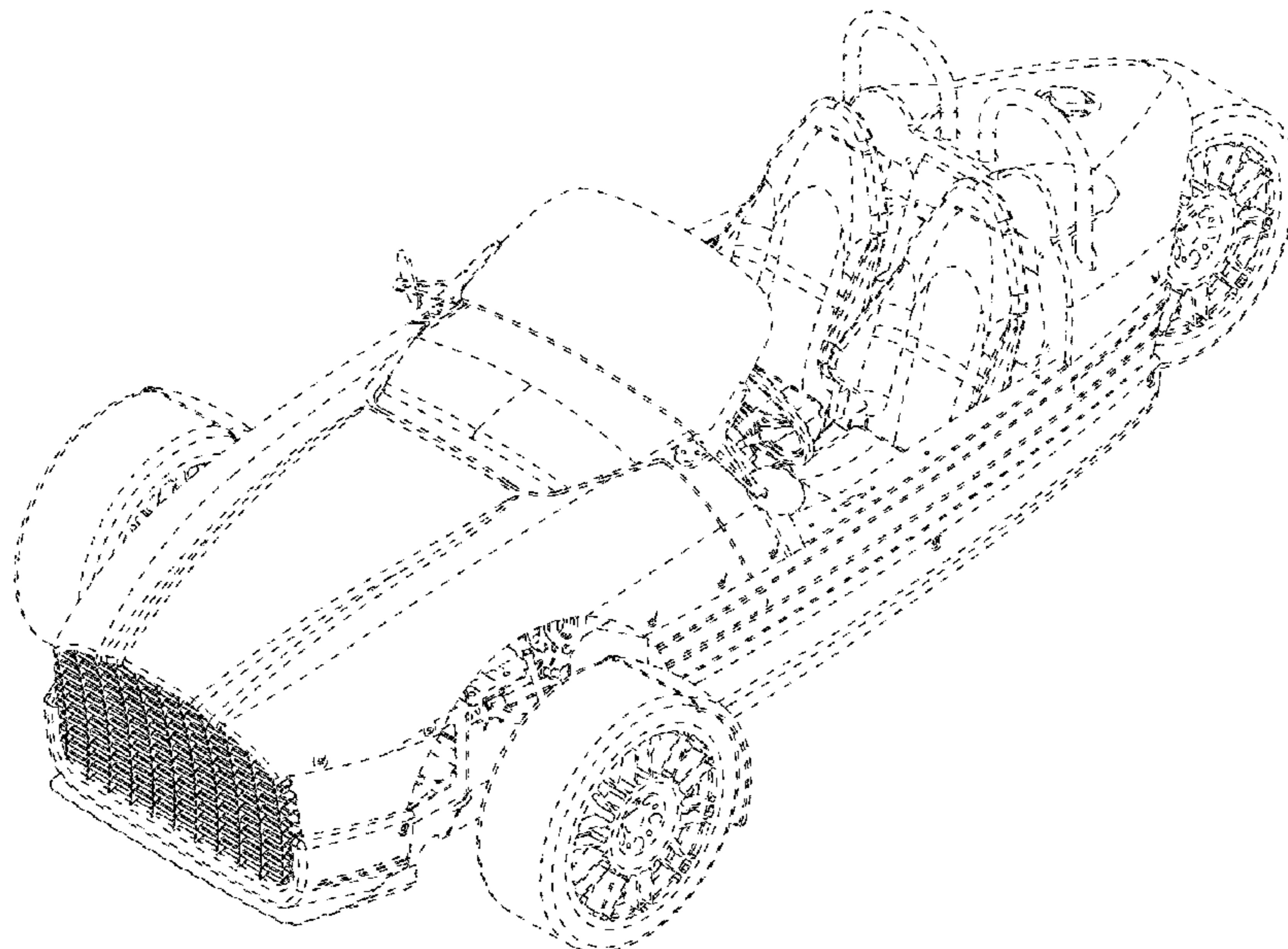

(56)

References Cited

U.S. PATENT DOCUMENTS

2018/0128605 A1* 5/2018 Hall G01B 11/275
2018/0134325 A1* 5/2018 Hall B62D 27/02
2018/0154942 A1* 6/2018 Hall B62D 21/152
2018/0186222 A1* 7/2018 Hall B60J 7/1628
2018/0229774 A1* 8/2018 Hall B62D 25/081
2018/0251172 A1* 9/2018 Hall B62D 65/00

OTHER PUBLICATIONS

http://www.prestigeelectriccar.com/en/news/2287/Vanderhall_Edison_2_electric_three-wheeler_from_America Nov. 21, 2017 (Year: 2017).*

<https://newatlas.com/vanderhall-edison2-auto-cycle/52265/> Nov. 20, 2017 (Year: 2017).*

<https://vanderhallusa.com/edison/> Dec. 2017 (Year: 2017).*

* cited by examiner

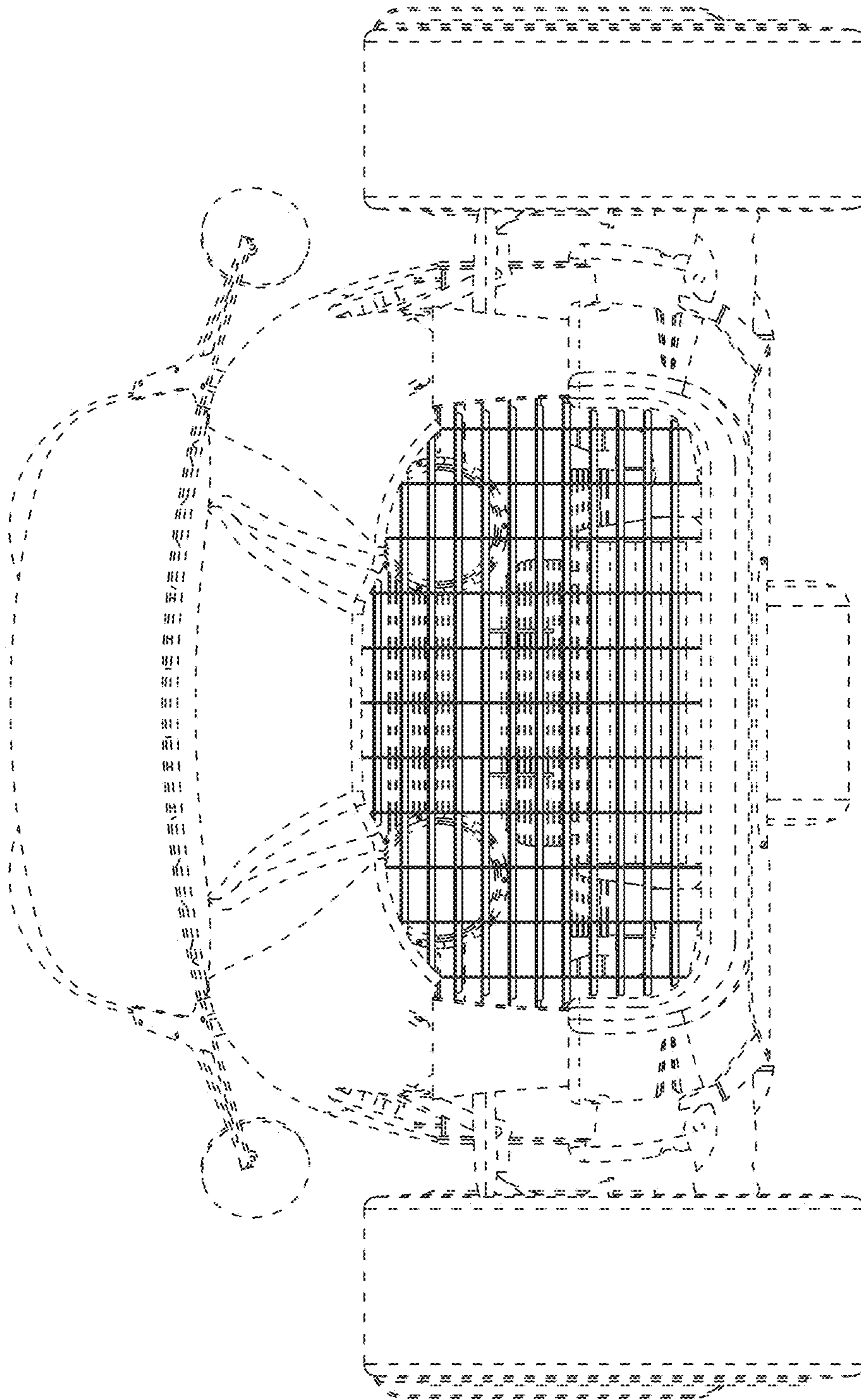

FIG. 1

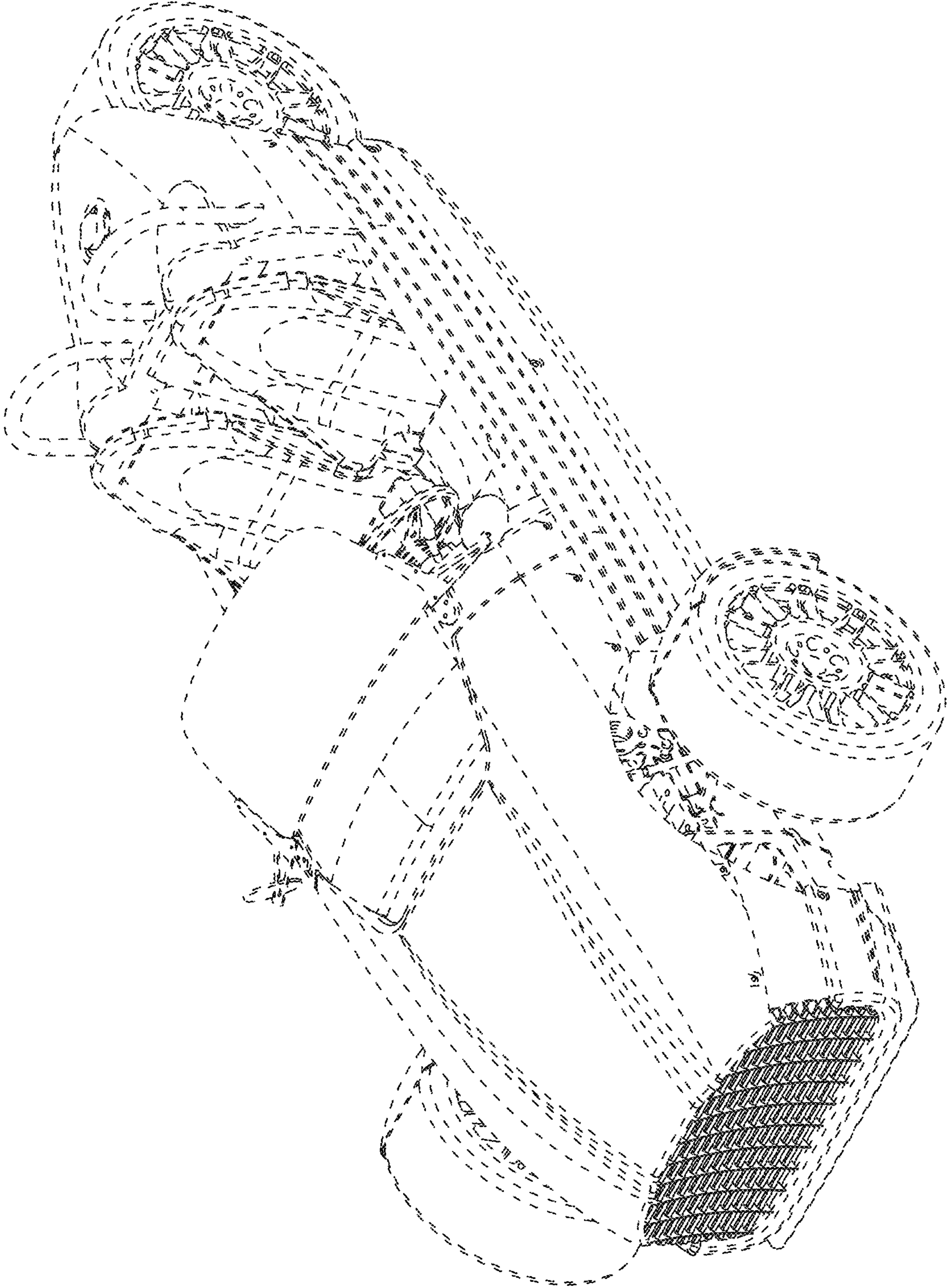

FIG. 2

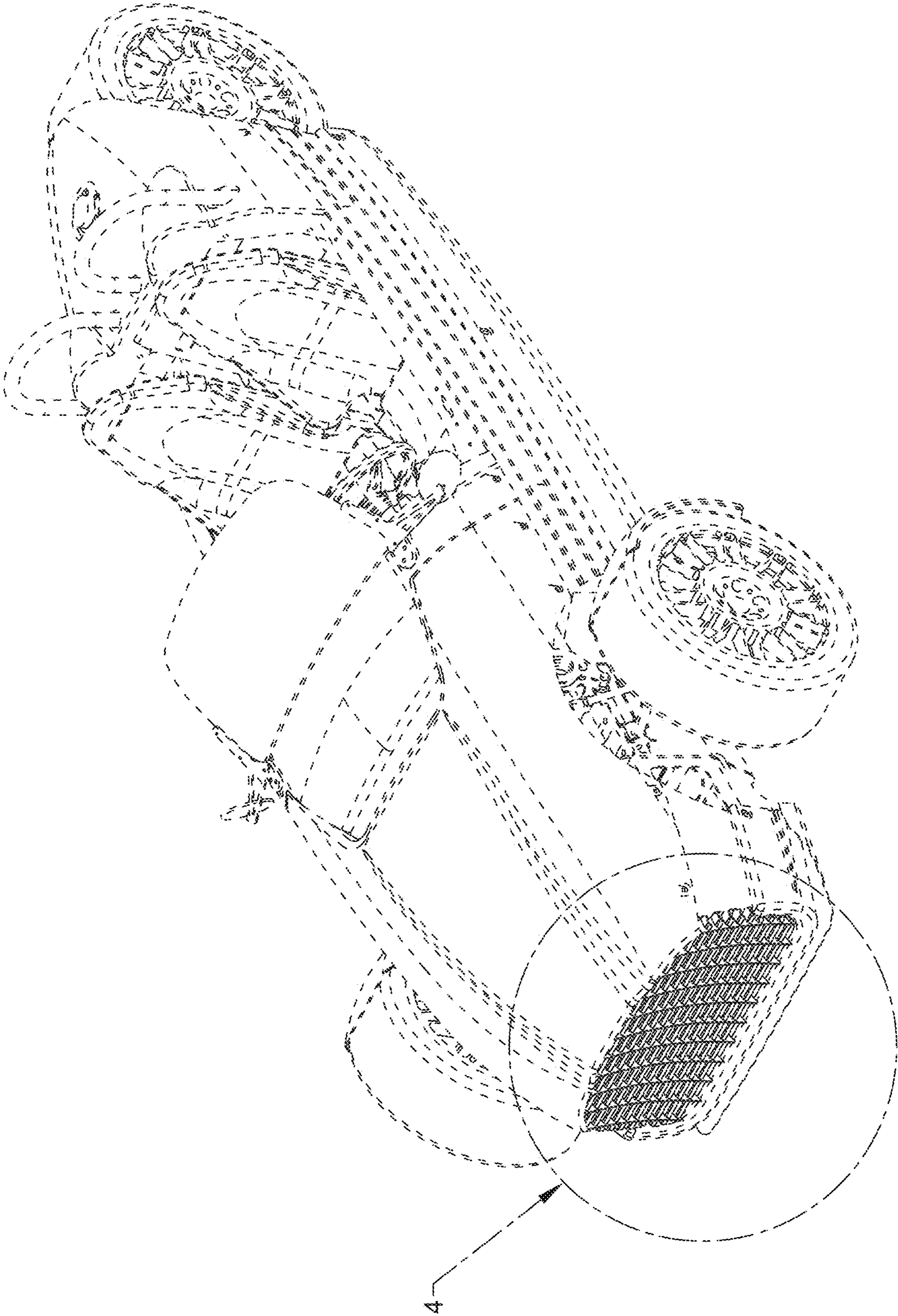

FIG. 3

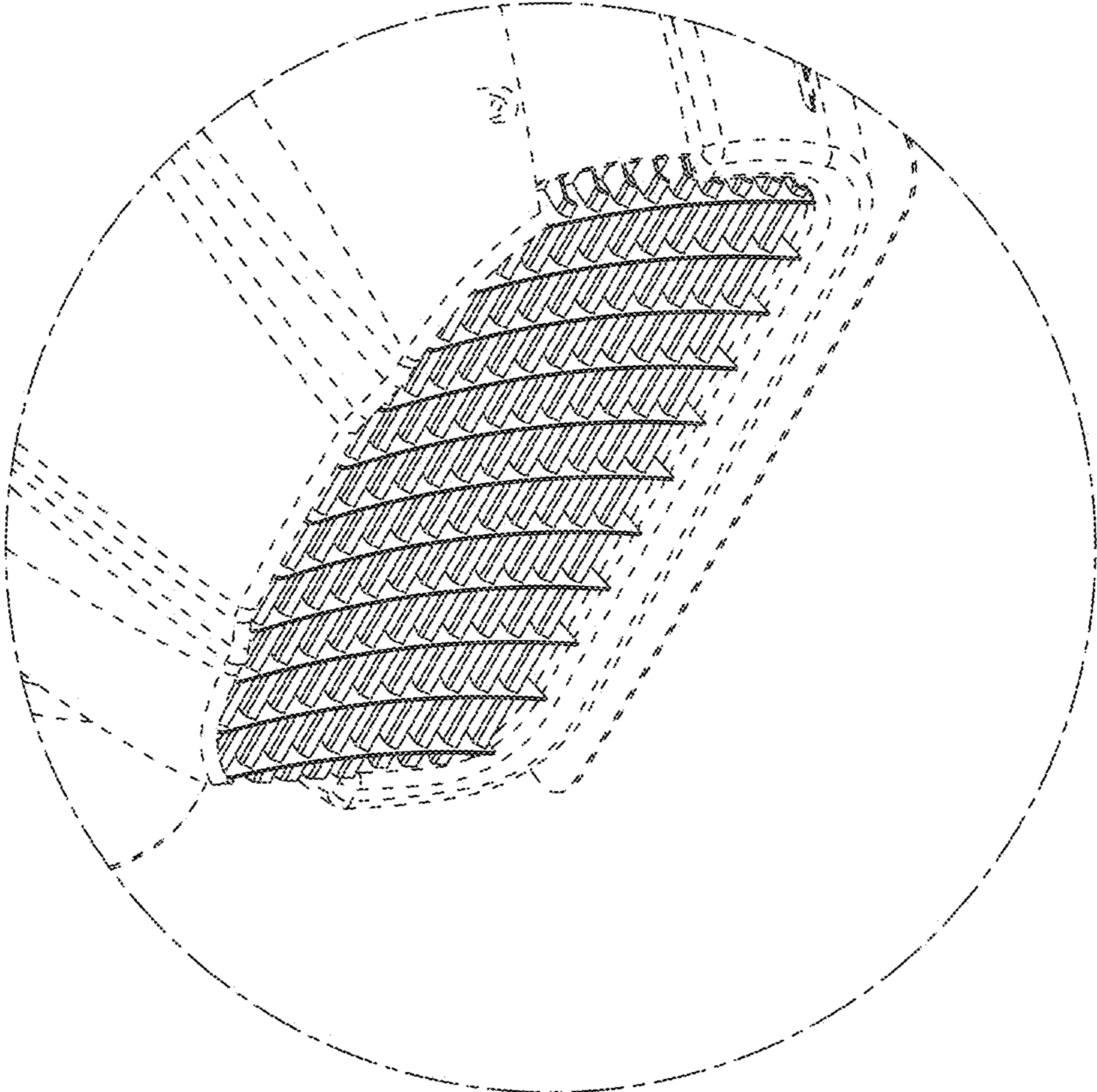

FIG. 4

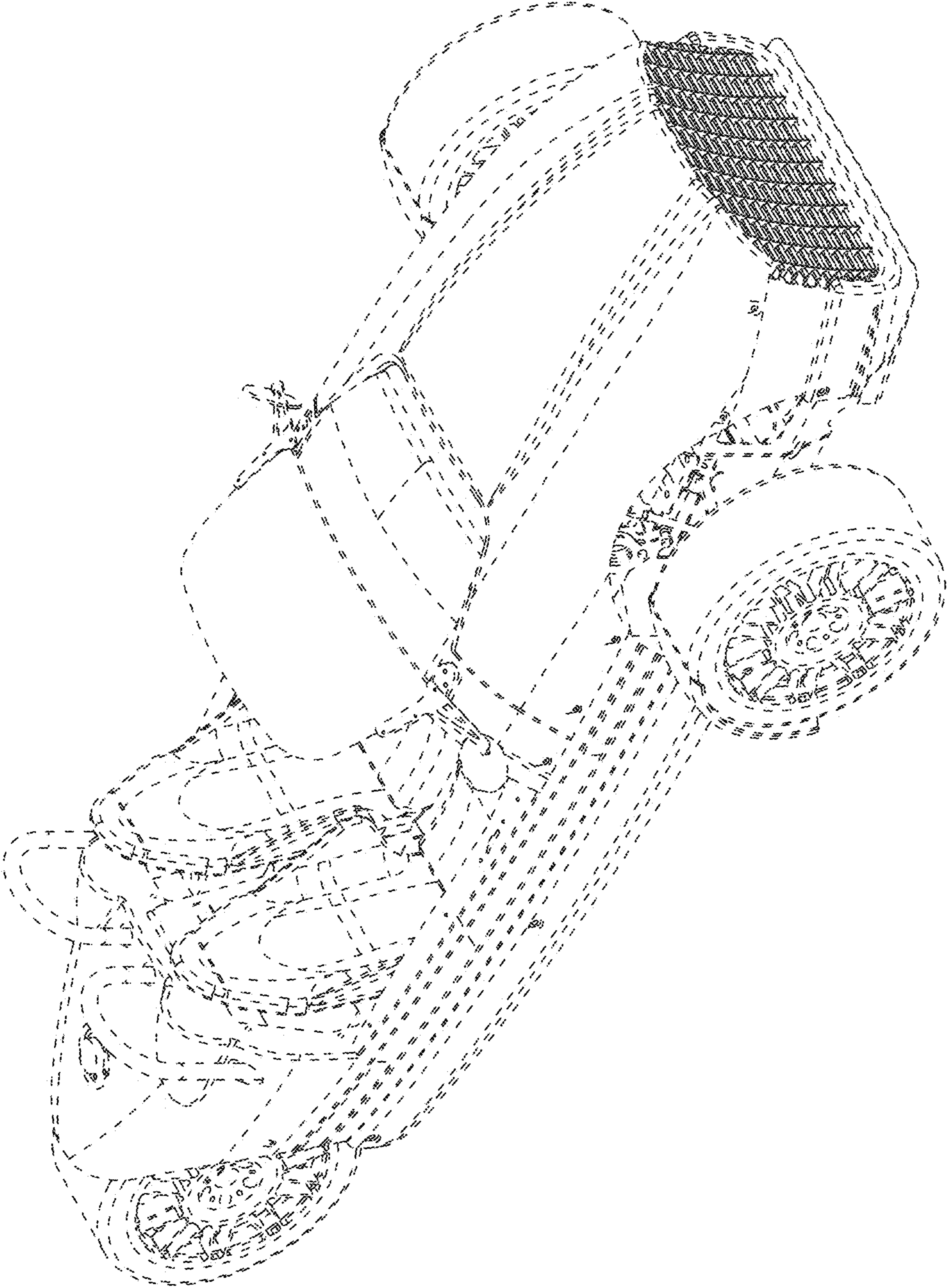

FIG. 5

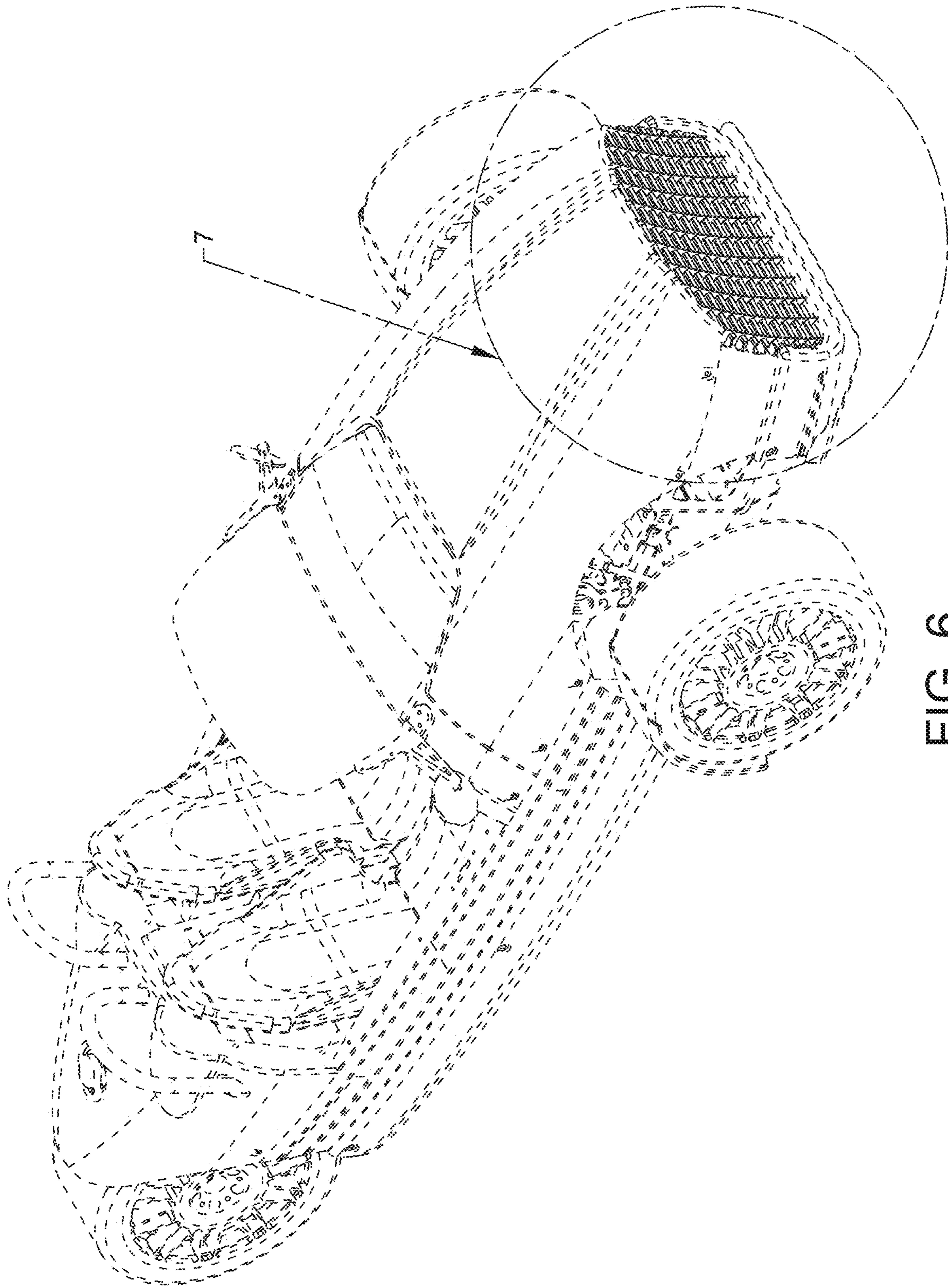

FIG. 6

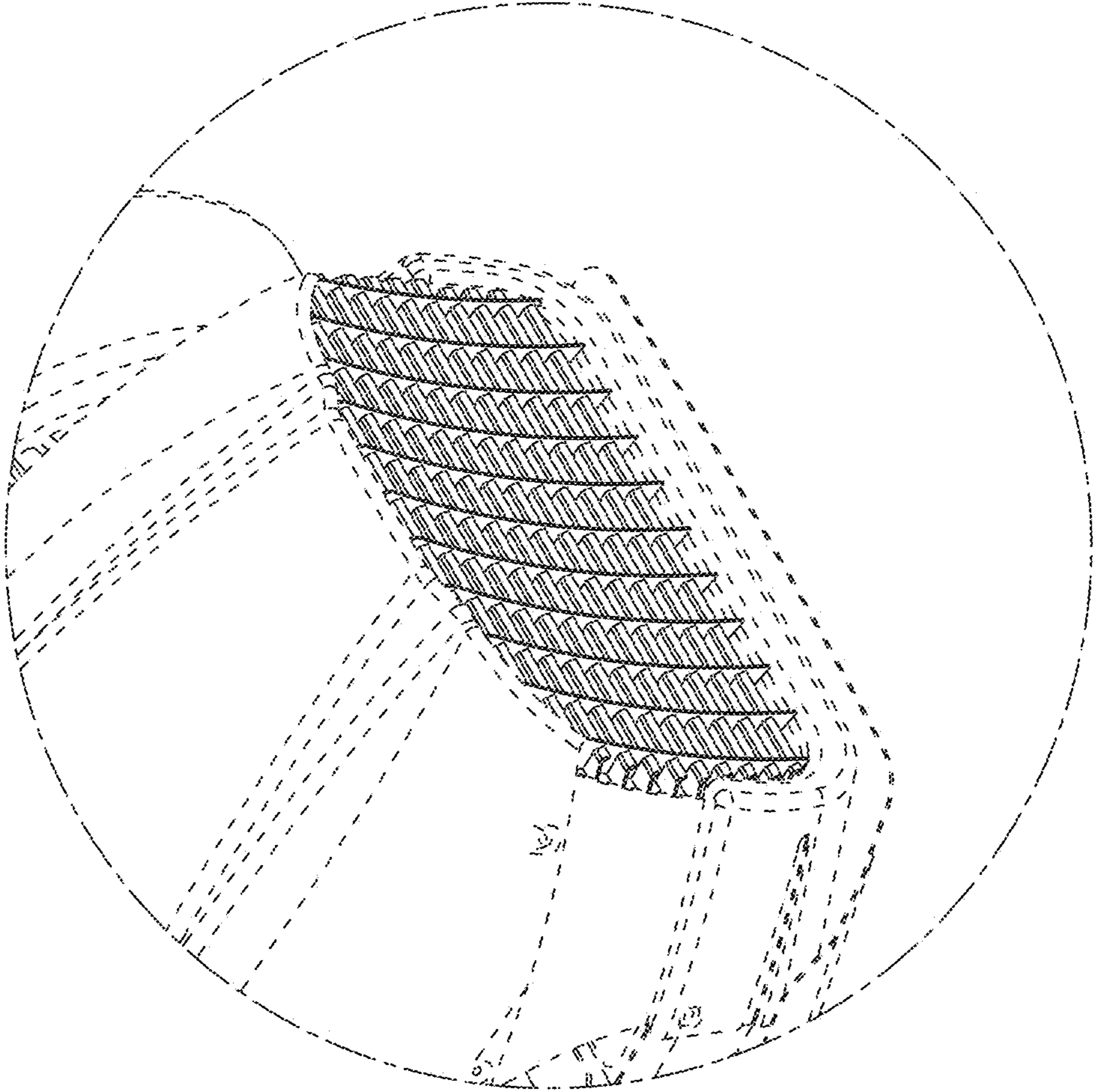

FIG. 7

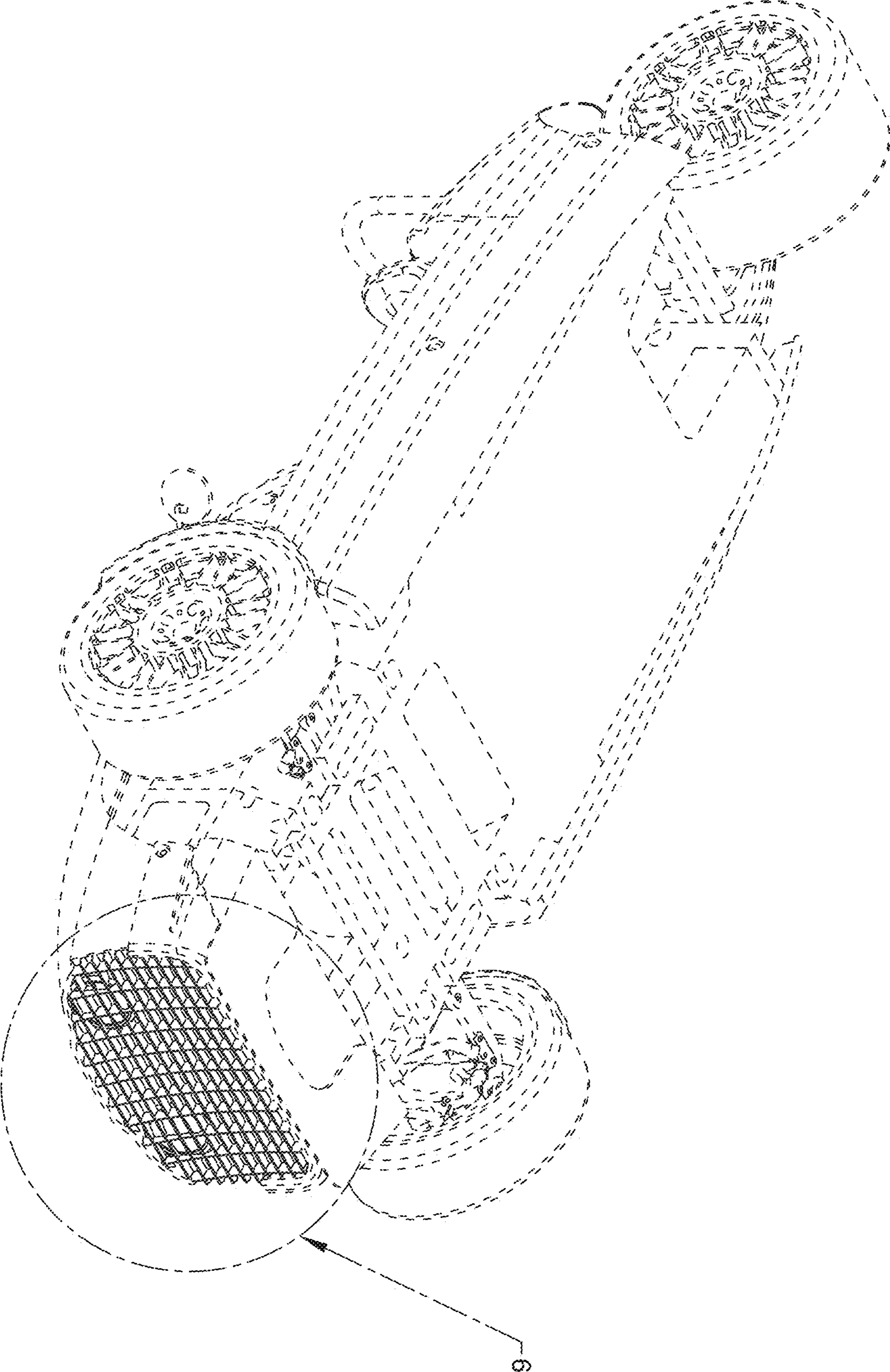

FIG. 8

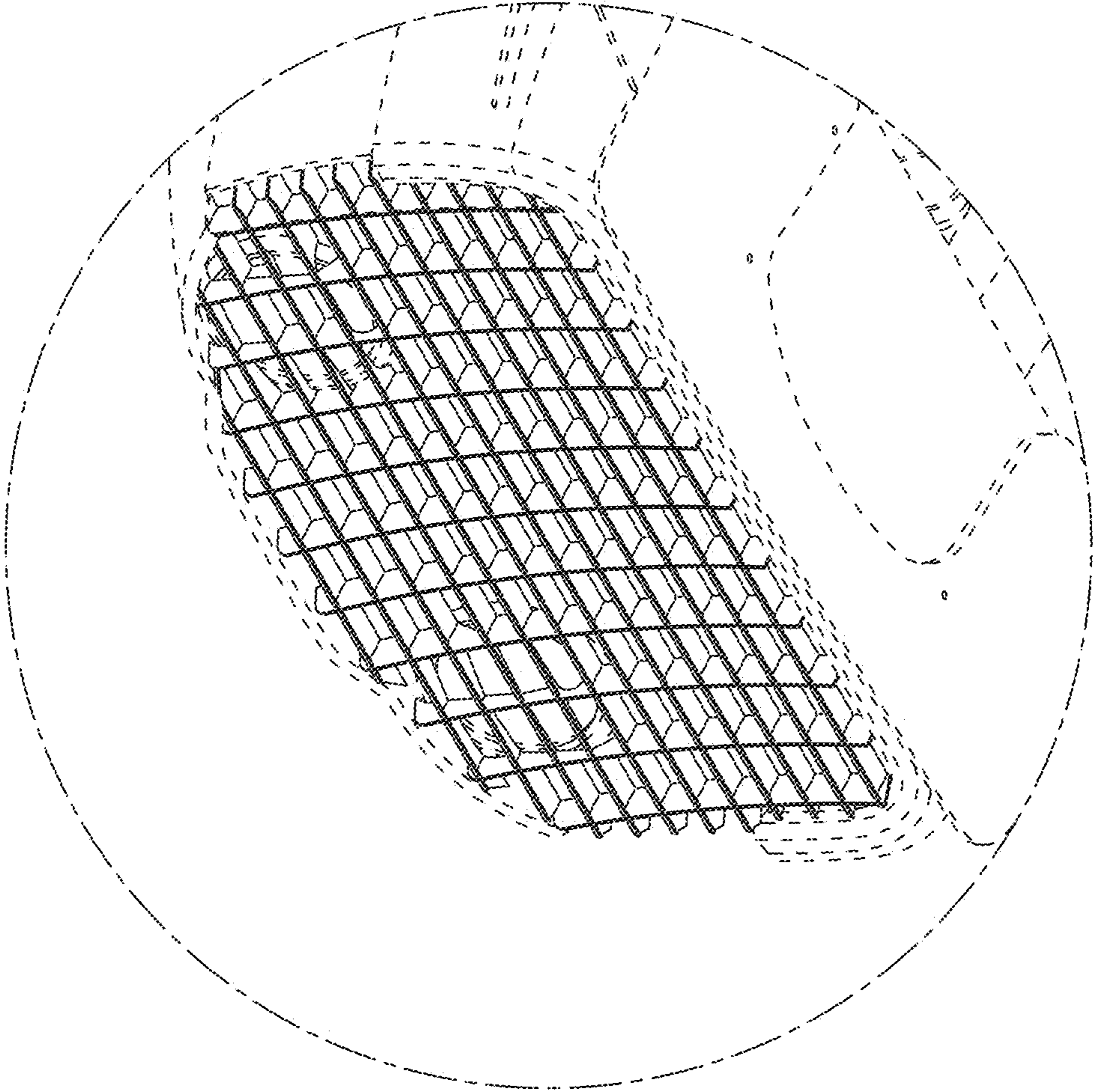

FIG. 9

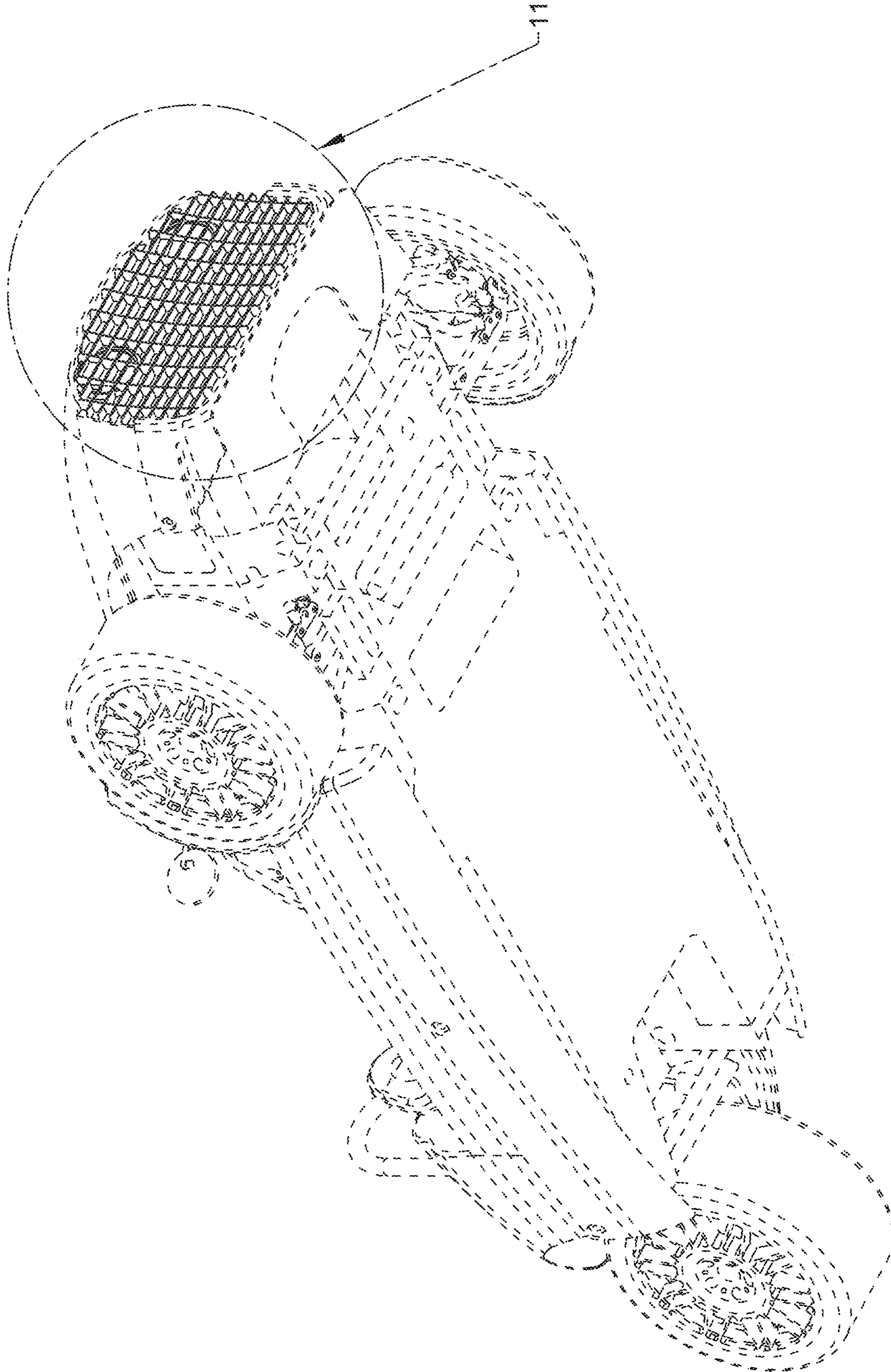

FIG. 10

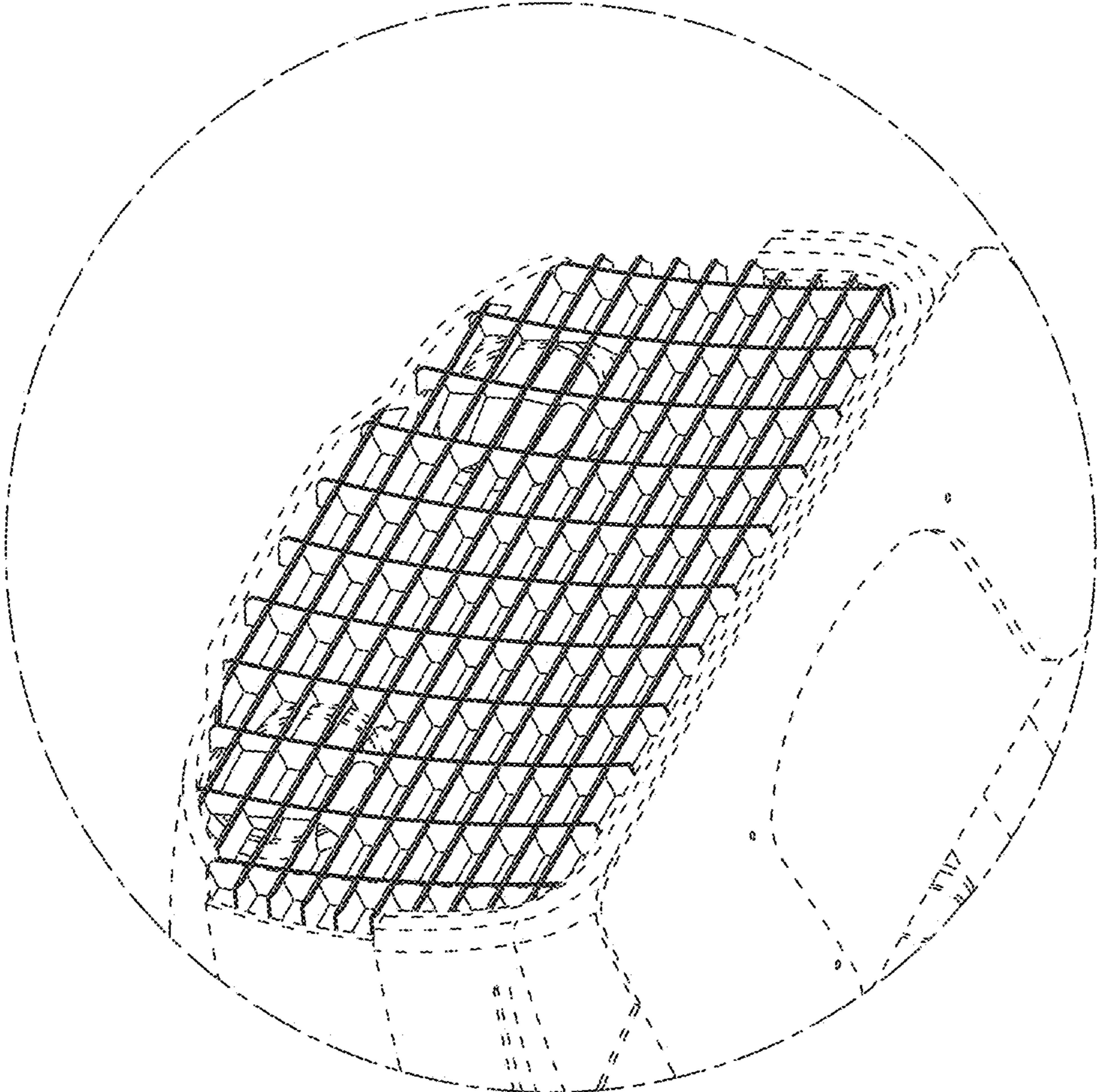

FIG. 11