



US00D872681S

(12) **United States Design Patent**
Tzarnotzky et al.

(10) **Patent No.:** **US D872,681 S**
(45) **Date of Patent:** **** Jan. 14, 2020**

- (54) **AIRCRAFT**
- (71) Applicant: **Cora Aero LLC**, Mountain View, CA (US)
- (72) Inventors: **Uri Tzarnotzky**, Sunnyvale, CA (US);
James Joseph Tighe, San Jose, CA (US); **Herve Martins-Rivas**, Mountain View, CA (US)
- (73) Assignee: **CORA AERO LLC**, Mountain View, CA (US)

- D190,004 S 3/1961 Doak
- D190,534 S 6/1961 Smolinski
- D192,195 S 2/1962 Stepniewski
- D192,337 S 3/1962 Skaggs
- D192,665 S 4/1962 Stepniewski
- D193,122 S 6/1962 Walker
- D193,369 S 8/1962 Walker
- D193,452 S 8/1962 Rellis
- D194,817 S 3/1963 Paxhia
- D195,794 S 7/1963 Dancik
- D196,213 S 9/1963 Paxhia
- D201,892 S 8/1965 Katz

(Continued)

- (**) Term: **15 Years**
- (21) Appl. No.: **29/673,461**
- (22) Filed: **Dec. 14, 2018**

FOREIGN PATENT DOCUMENTS

- EM 0055188260001 7/2018
- EM 0055188260002 7/2018

OTHER PUBLICATIONS

New autonomous flying car reveals in NZ by motoring. dated Mar. 15, 2018. found online [Oct. 12, 2018] <https://www.motoring.com.au/new-autonomous-flying-car-revealed-in-nz-111606/>.

Primary Examiner — Marissa J Cash
(74) *Attorney, Agent, or Firm* — Kilpatrick Townsend & Stockton LLP

Related U.S. Application Data

- (63) Continuation of application No. 29/640,152, filed on Mar. 12, 2018, now Pat. No. Des. 843,306.
- (51) **LOC (12) Cl.** **12-07**
- (52) **U.S. Cl.**
USPC **D12/329**; D12/16.1; D12/326
- (58) **Field of Classification Search**
USPC D12/1-4, 16.1, 319-345; D21/436-454
CPC B64C 39/024; B64C 13/16; B64C 19/00;
B64C 2201/021; B64C 2201/141; B60H
1/3442

See application file for complete search history.

(57) **CLAIM**

We claim the ornamental design for an aircraft, as shown and described.

DESCRIPTION

FIG. 1 is a perspective view taken from a top, front, and left side of an aircraft.
FIG. 2 is a front view of the aircraft of FIG. 1.
FIG. 3 is a rear view of the aircraft of FIG. 1.
FIG. 4 is a left view of the aircraft of FIG. 1.
FIG. 5 is a right view of the aircraft of FIG. 1.
FIG. 6 is a top view of the aircraft of FIG. 1; and,
FIG. 7 is a bottom view of the aircraft of FIG. 1.

- (56) **References Cited**
- U.S. PATENT DOCUMENTS**
- D91,444 S 1/1934 Shelton
- D119,714 S 3/1940 Hibbard
- D145,680 S 10/1946 Sebold
- D148,673 S 2/1948 Boyes
- D162,517 S 3/1951 Burnelli
- 2,752,114 A 6/1956 Calvy
- D183,383 S 8/1958 Projo De Asis

1 Claim, 7 Drawing Sheets

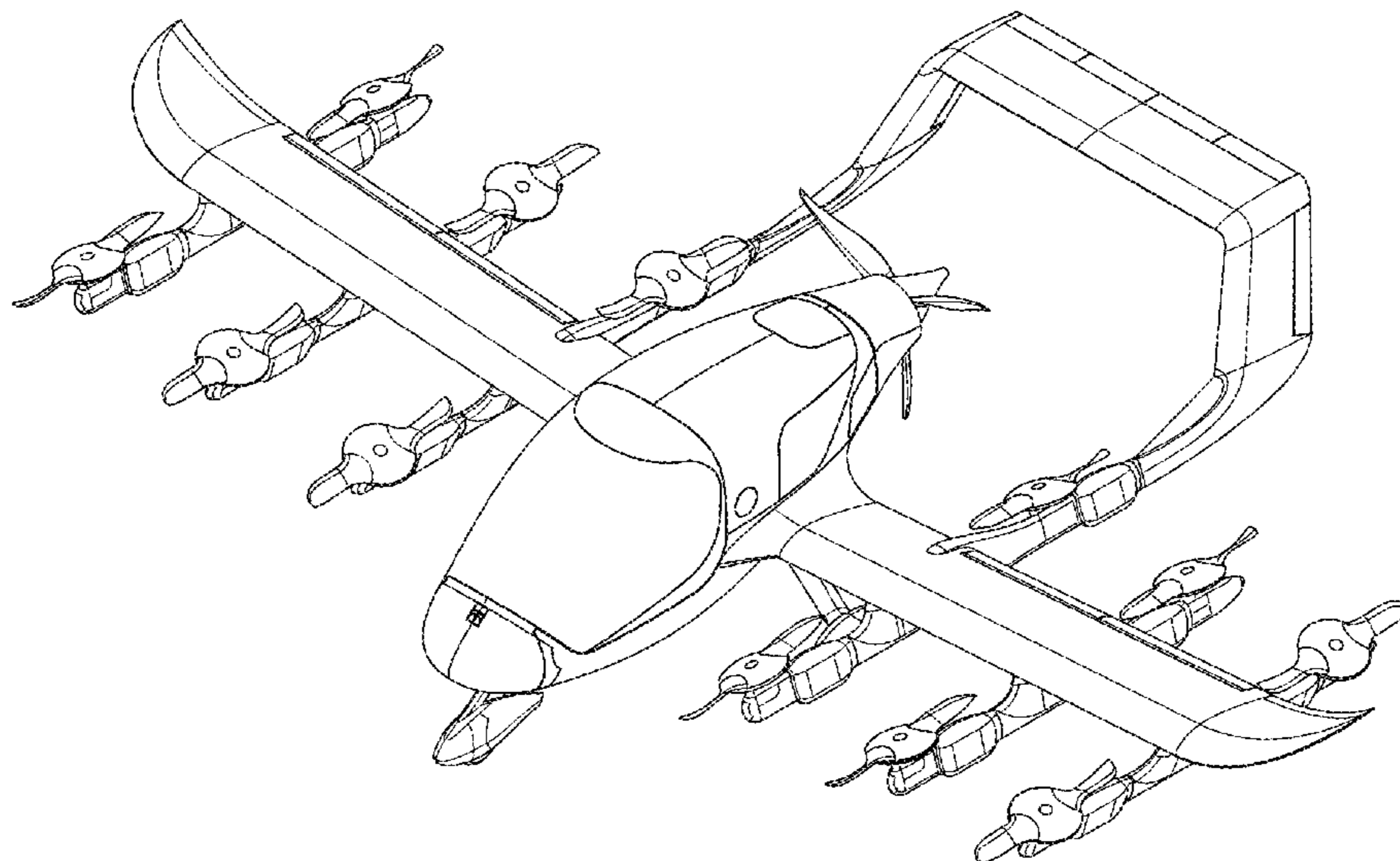

(56)

References Cited

U.S. PATENT DOCUMENTS

D203,283 S	12/1965	Woods	9,764,833 B1	9/2017	Tighe	
3,360,217 A	12/1967	Trotter	9,783,288 B1	10/2017	Moore	
D217,402 S	4/1970	Miller	D801,856 S	11/2017	Zhou	
D223,869 S	6/1972	Hurkamp	D803,724 S	11/2017	Zhou	
D232,711 S	9/1974	Kirchner	9,845,150 B2	12/2017	Kroo	
D239,522 S	4/1976	Wheatley	D808,328 S	1/2018	Ivans	
D240,909 S	8/1976	Whitener	D808,329 S	1/2018	Parks	
D267,794 S	2/1983	Krojer	D809,970 S	2/2018	Zhou	
D292,194 S	10/1987	Moller	D810,653 S	2/2018	Hu	
4,746,082 A	5/1988	Syms	9,898,033 B1	2/2018	Long	
4,757,962 A	7/1988	Grant	9,944,386 B1	4/2018	Reichert	
4,848,702 A	7/1989	Riggins	D816,547 S	5/2018	Cui	
D319,805 S	9/1991	Wiegert	D816,583 S	5/2018	Dutertre	
D326,255 S	5/1992	Graham	9,957,042 B1	5/2018	Vander Lind	
5,115,996 A	5/1992	Moller	9,975,631 B1	5/2018	McLaren	
D446,182 S	8/2001	Adam, Jr.	D821,263 S	6/2018	Goldy	
D454,109 S	3/2002	Moshier	D822,579 S	7/2018	Lienhard	
D493,411 S	7/2004	Fong	10,011,348 B1	7/2018	Wong	
D498,201 S	11/2004	Moller	D824,804 S	8/2018	Tian	
D500,729 S	1/2005	Wilding	D832,141 S *	10/2018	Ferner	D12/16.1
D500,981 S	1/2005	Wilding	D843,305 S *	3/2019	MacAndrew	D12/319
D516,008 S	2/2006	Vigieron	D843,306 S *	3/2019	Tzarnotzky	D12/329
D573,939 S	7/2008	Las Heras	D843,889 S *	3/2019	Merrill	D12/16.1
D592,582 S	5/2009	Tamm	D843,919 S *	3/2019	Tzarnotzky	D12/329
D605,576 S	12/2009	Posva	D852,092 S *	6/2019	Woodworth	D12/16.1
D612,317 S	3/2010	Stinemetze	2006/0016930 A1	1/2006	Pak	
D634,257 S	3/2011	Alexander	2008/0142643 A1	6/2008	Yoeli	
D665,333 S	8/2012	Oliver	2008/0283673 A1	11/2008	Yoeli	
D678,169 S	3/2013	Kennelly	2010/0181414 A1	7/2010	Lopez, Jr.	
D696,618 S	12/2013	Wang	2012/0043413 A1	2/2012	Smith	
D708,272 S	7/2014	Schmelter	2012/0091257 A1	4/2012	Wolff	
D717,227 S	11/2014	Herzberger	2012/0234968 A1	9/2012	Smith	
D724,001 S	3/2015	Garreau	2014/0339372 A1	11/2014	Dekel	
9,120,560 B1	9/2015	Armer	2016/0144956 A1	5/2016	Parks	
D740,201 S	10/2015	Wang	2016/0167780 A1	6/2016	Giovenga	
D741,247 S	10/2015	Brody	2016/0200436 A1	7/2016	North	
D741,751 S	10/2015	Klaptocz	2016/0229531 A1	8/2016	Robertson	
D743,868 S	11/2015	Cummings	2016/0236774 A1	8/2016	Niedzballa	
D747,775 S	1/2016	Colin	2016/0244158 A1	8/2016	Fredericks	
D751,025 S	3/2016	Howell	2017/0210481 A1	7/2017	Bak	
D761,690 S	7/2016	Friesmuth	2017/0300065 A1	10/2017	Douglas	
D778,371 S	2/2017	Barajas	2017/0300067 A1	10/2017	Douglas	
D779,595 S	2/2017	Xiao	2017/0349281 A1	12/2017	Quinlan	
D789,248 S	6/2017	Ketcher	2017/0369161 A1	12/2017	Alzahrani	
9,694,911 B2	7/2017	Bevirt	2018/0057157 A1	3/2018	Groninga	
			2018/0162525 A1	6/2018	St Clair	
			2018/0290735 A1	10/2018	Uptigrove	

* cited by examiner

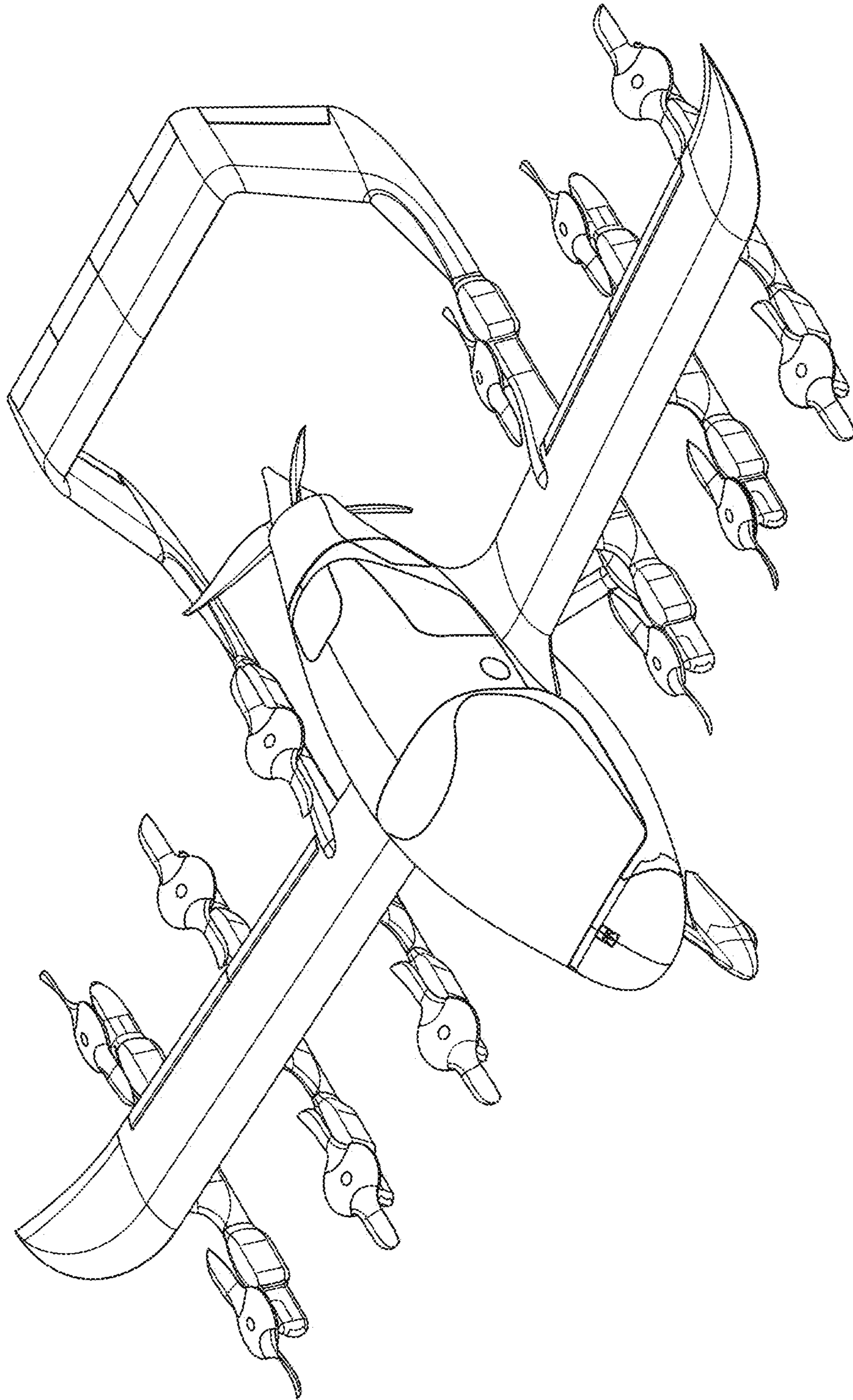

FIG. 1

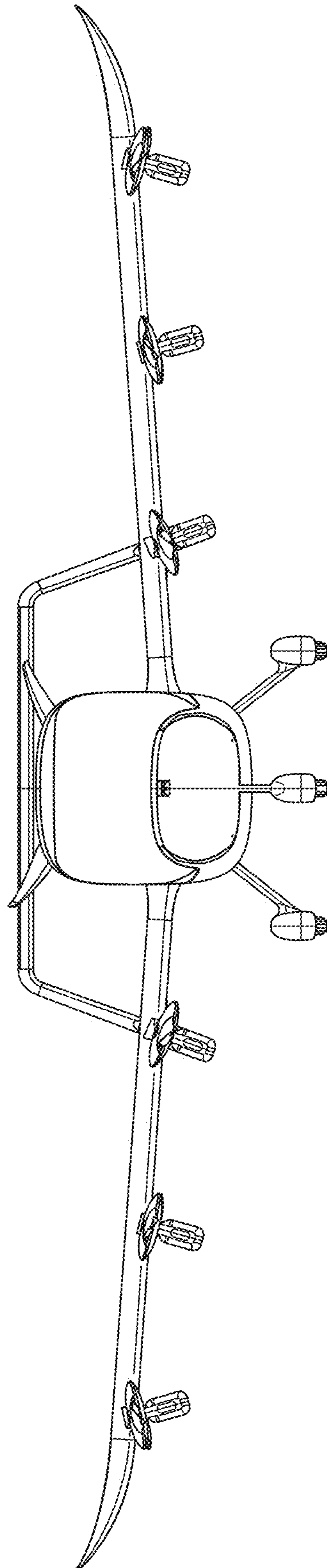

FIG. 2

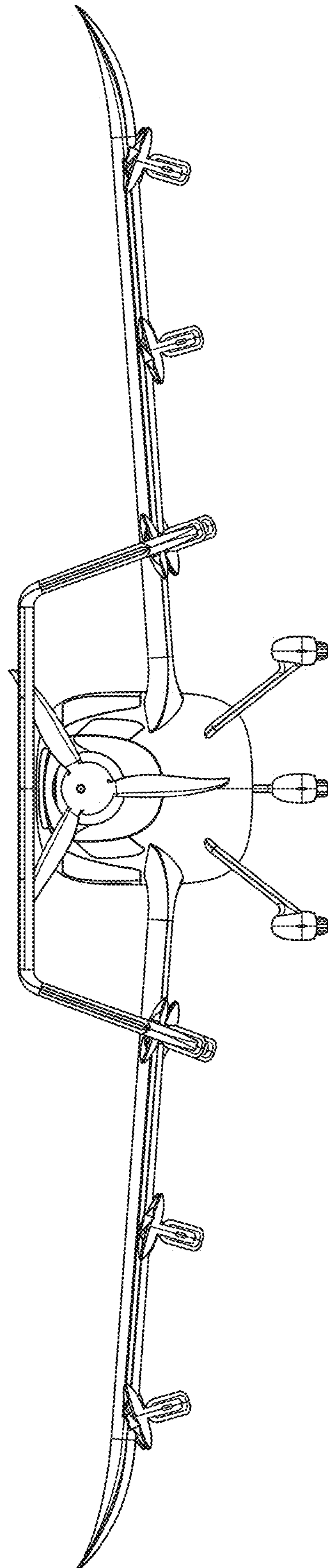

FIG. 3

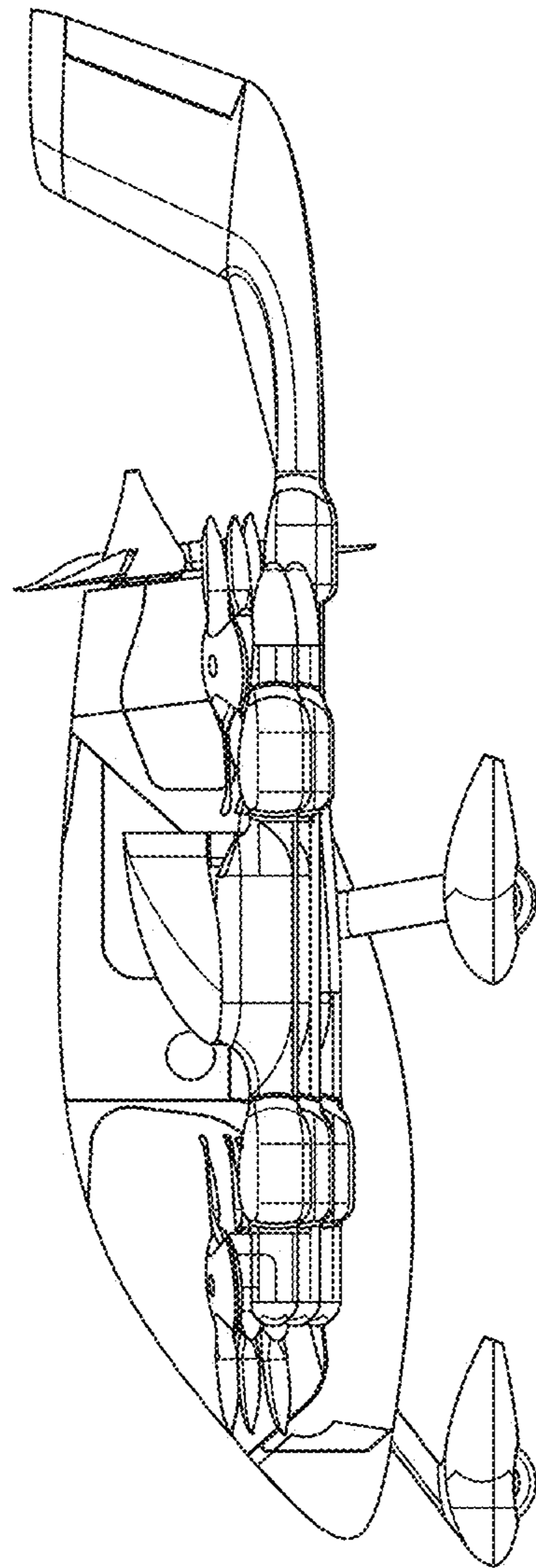

FIG. 4

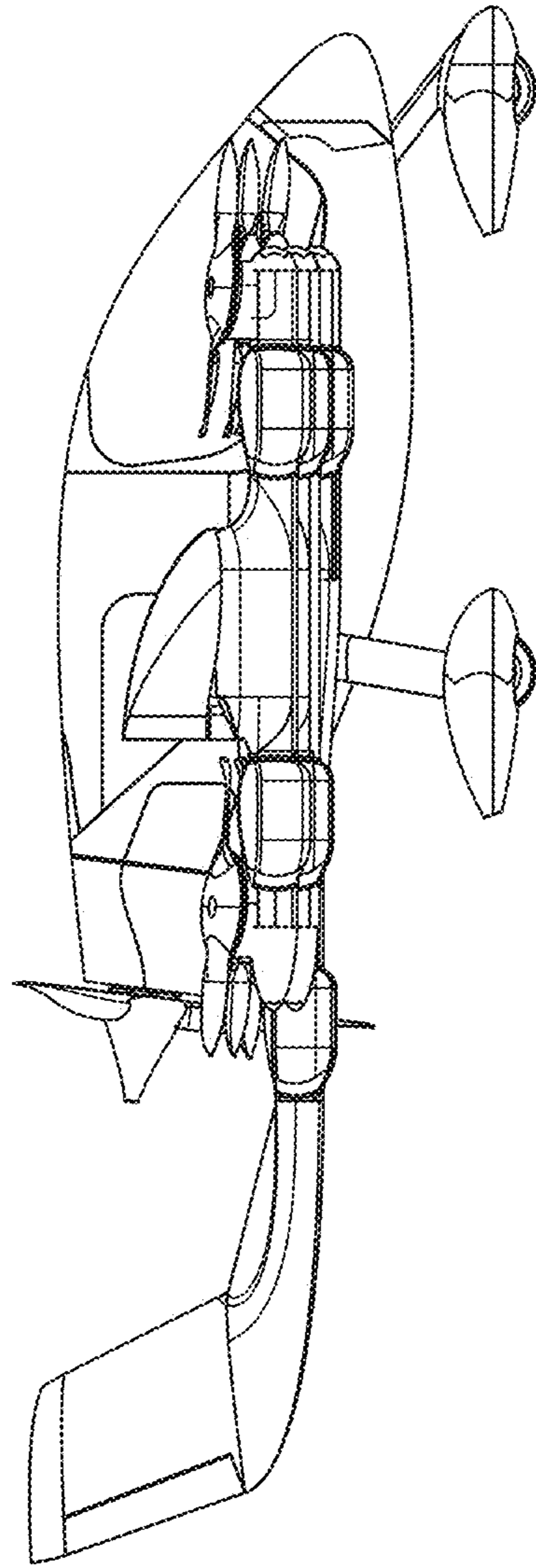

FIG. 5

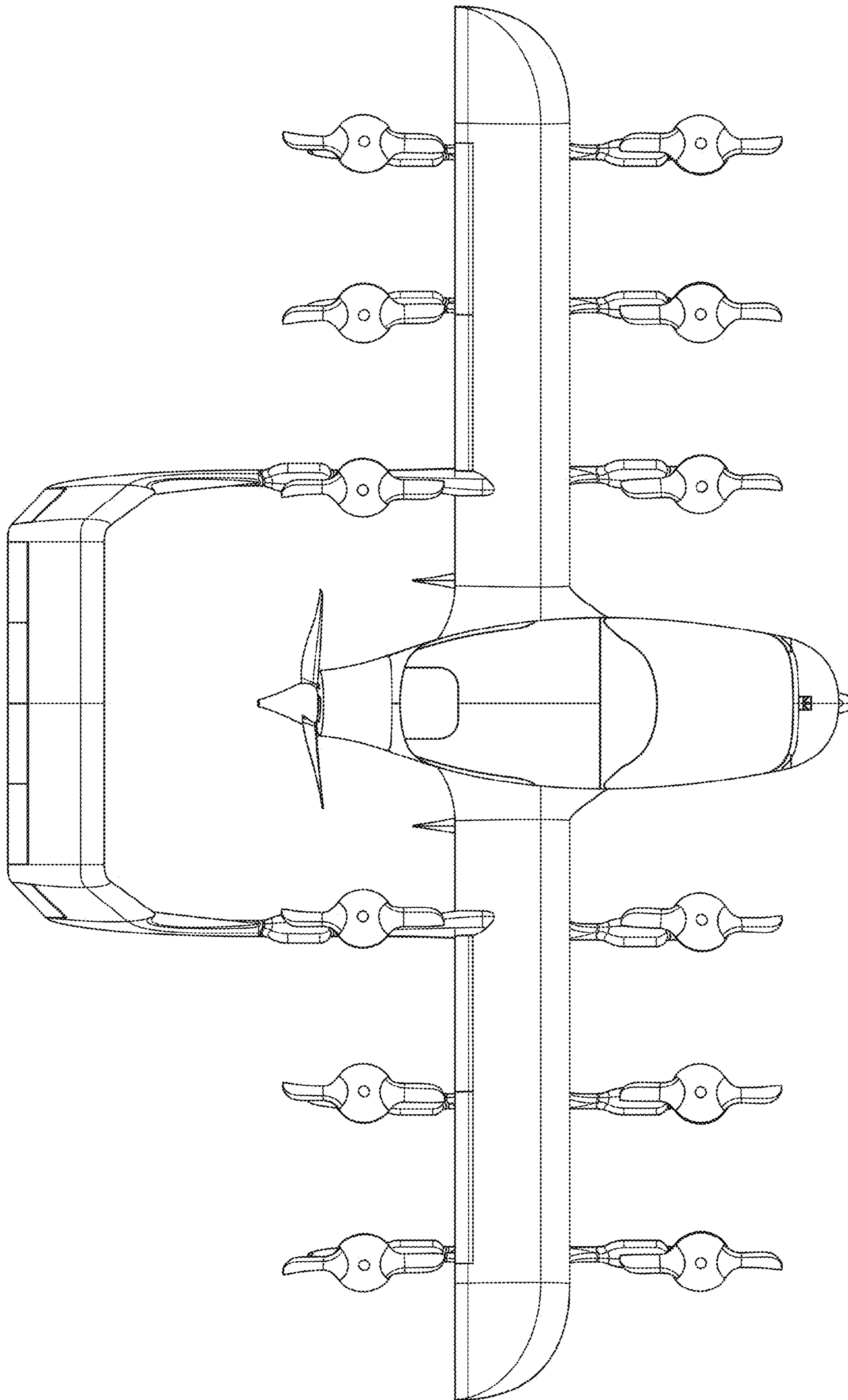

FIG. 6

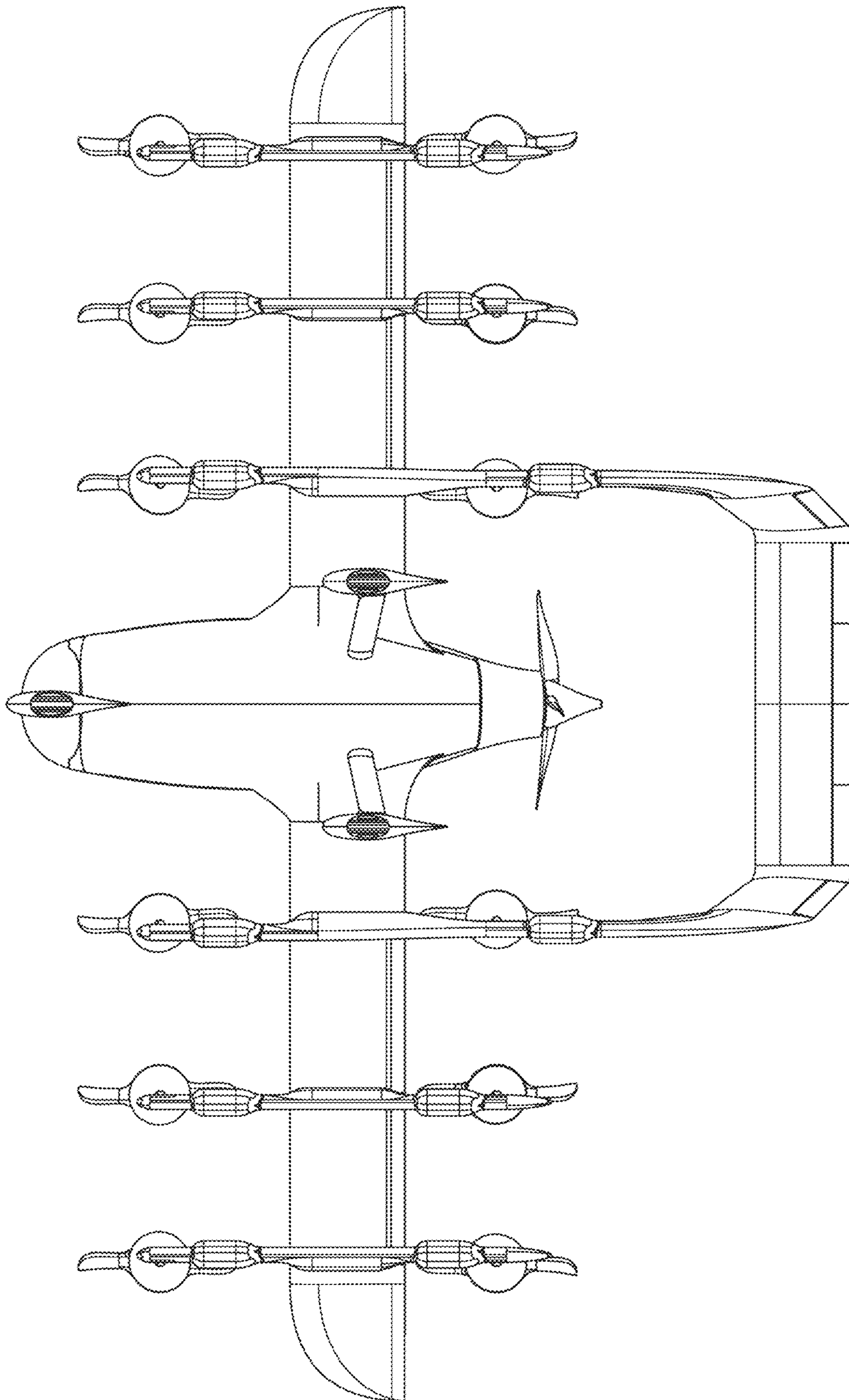

FIG. 7