



US00D872145S

(12) **United States Design Patent** (10) **Patent No.:** **US D872,145 S**  
**Maeno et al.** (45) **Date of Patent:** **\*\* Jan. 7, 2020**

(54) **CUTTING TOOL**

(74) *Attorney, Agent, or Firm* — Baker Botts L.L.P.;  
Michael A. Sartori

(71) Applicant: **SUMITOMO ELECTRIC  
HARDMETAL CORP.**, Itami-shi (JP)

(57) **CLAIM**

(72) Inventors: **Hideo Maeno**, Itami (JP); **Yosuke  
Shimamoto**, Itami (JP); **Naoki  
Matsuda**, Itami (JP)

The ornamental design for a cutting tool, as shown and  
described.

(73) Assignee: **SUMITOMO ELECTRIC  
HARDMETAL CORP.**, Itami-shi (JP)

**DESCRIPTION**

(\*\*) Term: **15 Years**

FIG. 1 is a front view of a cutting tool in accordance with  
Embodiment 1 of the present design;  
FIG. 2 is a rear view thereof;  
FIG. 3 is a top view thereof;  
FIG. 4 is a bottom view thereof;  
FIG. 5 is a right side view thereof;  
FIG. 6 is a left side view thereof;  
FIG. 7 is a perspective view thereof;  
FIG. 8 is an enlarged view of 8-8 portion of FIG. 3;  
FIG. 9 is an enlarged perspective view of 8-8 portion of FIG.  
3;

(21) Appl. No.: **29/670,674**

(22) Filed: **Nov. 19, 2018**

FIG. 10 is an enlarged front view of 8-8 portion of FIG. 3;  
FIG. 11 is an enlarged rear view of 8-8 portion of FIG. 3;  
FIG. 12 is an enlarged left side view of 8-8 portion of FIG.  
3;

**Related U.S. Application Data**

(62) Division of application No. 29/592,600, filed on Jan.  
31, 2017.

FIG. 13 is a cross sectional view taken along line 13-13 of  
FIG. 3;

(30) **Foreign Application Priority Data**

Jun. 17, 2016 (JP) ..... 2016-013008

Jun. 17, 2016 (JP) ..... 2016-013009

(Continued)

FIG. 14 is a cross sectional view taken along line 14-14 of  
FIG. 3;

(51) **LOC (12) Cl.** ..... **15-03**

(52) **U.S. Cl.**  
USPC ..... **D15/139**

FIG. 15 is a cross sectional view taken along line 15-15 of  
FIG. 8;

(58) **Field of Classification Search**  
USPC ..... D15/131, 138, 139, 140; D8/70

(Continued)

FIG. 16 is a cross sectional view taken along line 16-16 of  
FIG. 8;

(56) **References Cited**

**U.S. PATENT DOCUMENTS**

D503,181 S \* 3/2005 Kasperik ..... D15/139

D522,025 S \* 5/2006 Niebauer ..... D15/139

(Continued)

FIG. 17 is a cross sectional view taken along line 17-17 of  
FIG. 8;

FIG. 18 is a cross sectional view taken along line 18-18 of  
FIG. 8;

FIG. 19 is a cross sectional view taken along line 19-19 of  
FIG. 8;

FIG. 20 is a referential enlarged perspective view of 8-8  
portion of FIG. 3;

FIG. 21 is a front view of a cutting tool in accordance with  
Embodiment 2 of the present design;

FIG. 22 is a rear view thereof;

(Continued)

*Primary Examiner* — Khawaja Anwar

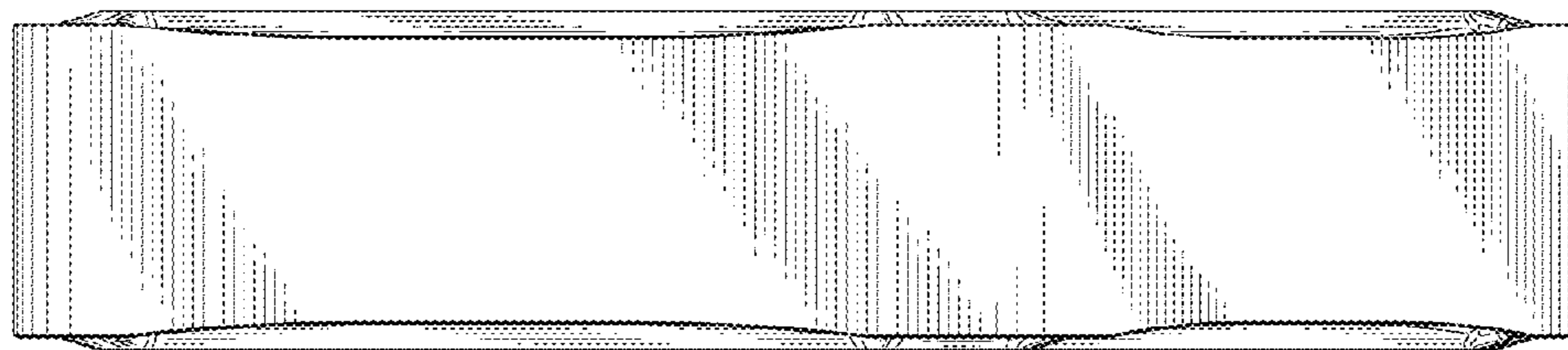

FIG. 23 is a top view thereof;  
 FIG. 24 is a bottom view thereof;  
 FIG. 25 is a right side view thereof;  
 FIG. 26 is a left side view thereof;  
 FIG. 27 is a perspective view thereof;  
 FIG. 28 is an enlarged view of 28-28 portion of FIG. 23;  
 FIG. 29 is an enlarged perspective view of 28-28 portion of FIG. 23;  
 FIG. 30 is an enlarged front view of 28-28 portion of FIG. 23;  
 FIG. 31 is an enlarged rear view of 28-28 portion of FIG. 23;  
 FIG. 32 is an enlarged left side view of 28-28 portion of FIG. 23;  
 FIG. 33 is a cross sectional view taken along line 33-33 of FIG. 23;  
 FIG. 34 is a cross sectional view taken along line 34-34 of FIG. 23;  
 FIG. 35 is a cross sectional view taken along line 35-35 of FIG. 28;  
 FIG. 36 is a cross sectional view taken along line 36-36 of FIG. 28;  
 FIG. 37 is a cross sectional view taken along line 37-37 of FIG. 28;  
 FIG. 38 is a cross sectional view taken along line 38-38 of FIG. 28;  
 FIG. 39 is a cross sectional view taken along line 39-39 of FIG. 28; and,  
 FIG. 40 is a referential enlarged perspective view of 28-28 portion of FIG. 23.

**1 Claim, 20 Drawing Sheets**

(30) **Foreign Application Priority Data**

Jun. 17, 2016 (JP) ..... 2016-013010  
 Jun. 17, 2016 (JP) ..... 2016-013011  
 Jun. 17, 2016 (JP) ..... 2016-013012

(58) **Field of Classification Search**

CPC ..... B23C 5/207; B23C 5/06; B23C 2200/125;  
 B23C 5/202; B23C 2200/203; B23C  
 2200/208; B23C 2210/168; B23C 5/109;  
 B23C 2200/128; B23C 2200/205; B23C  
 2200/367; B23C 5/20; B23C 5/2221;  
 B23C 2200/286; B23C 2200/0461; B23C  
 2200/0494; B23C 2200/085; B23C  
 2200/165; B23C 2200/201; B23C  
 2210/045; B23C 5/10; B23C 2200/0411;

B23C 2200/0416; B23C 2200/0455;  
 B23C 2200/123; B23C 2210/0457; B23C  
 5/006; B23C 5/2247; B23C 5/28; B23C  
 2200/0422; B23C 2200/0433; B23C  
 2200/0444; B23C 2200/045; B23C  
 2200/0477; B23C 2200/0483; B23C  
 2200/08; B23C 2200/086; B23C  
 2200/126; B23C 2200/164; B23C  
 2200/168; B23C 2200/28; B23C  
 2200/366; B23C 2210/16; B23C  
 2210/161; B23C 2220/16; B23C 2228/10;  
 B23C 2250/12; B23C 5/08; B23C 5/16;  
 B23C 5/205; B23C 5/2213; B23C 5/2273;  
 B23C 2200/0466; B23C 2200/12; B23C  
 2200/16; B23C 2200/161; B23C  
 2200/167; B23C 2200/206; B23C  
 2200/243; B23C 2200/246; B23C  
 2200/283; B23C 2200/326; B23C  
 2200/361; B23C 2200/368; B23C  
 2210/02; B23C 2210/03; B23C  
 2210/0414; B23C 2210/0428; B23C  
 2210/163; B23C 2210/202; B23C  
 2210/244; B23C 2210/28; B23C 2210/66;  
 B23C 2220/44; B23C 2220/56; B23C  
 2220/60; B23C 2222/28; B23C 2222/32;  
 B23C 2224/04; B23C 2224/28; B23C  
 2224/36; B23C 2226/125; B23C 2226/18;  
 B23C 2228/04; B23C 2240/24; B23C  
 2240/245; B23C 2240/32; B23C 2250/04;  
 B23C 2260/28; B23C 2265/08; B23C  
 3/12; B23C 5/003; B23C 5/1027; B23C  
 5/1045; B23C 5/18; B23C 5/22; B23C  
 5/2204; B23C 5/2208; B23C 5/2239;  
 B23C 5/2269; B23C 5/2406; B23C 5/241;  
 B23C 5/242; B23C 5/2462; B23C 5/2472

See application file for complete search history.

(56) **References Cited**

U.S. PATENT DOCUMENTS

D523,040 S \* 6/2006 Niebauer ..... D15/139  
 D632,320 S \* 2/2011 Chen ..... D15/139  
 D718,357 S \* 11/2014 Park ..... D15/139  
 D794,103 S \* 8/2017 Jeong ..... D15/139  
 D806,150 S \* 12/2017 Komiyama ..... D15/139  
 D816,744 S \* 5/2018 Lee ..... D15/139  
 D822,080 S \* 7/2018 Oh ..... D15/139  
 D822,731 S \* 7/2018 Yoshida ..... D15/139  
 D829,785 S \* 10/2018 Sakai ..... D15/139

\* cited by examiner

FIG.1

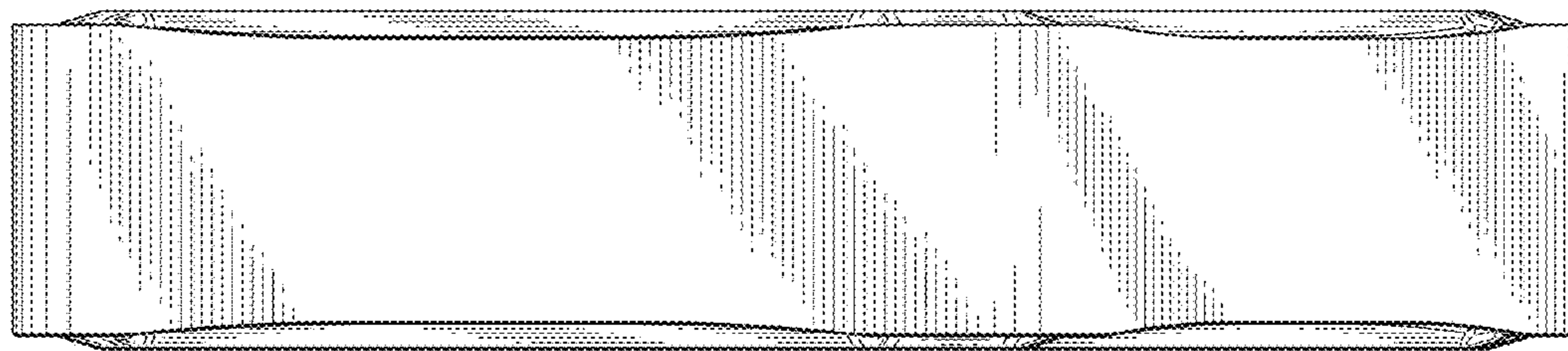

FIG.2

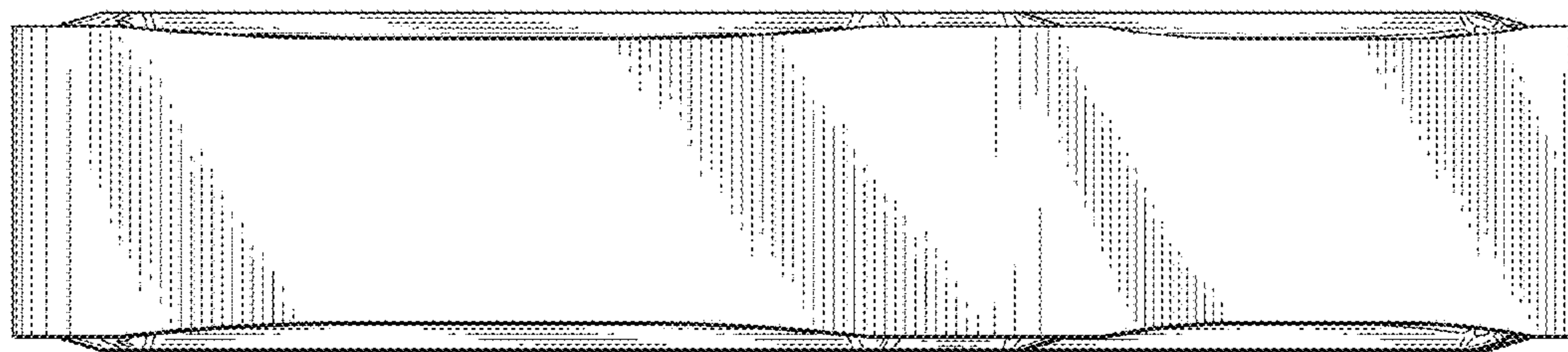



FIG.3

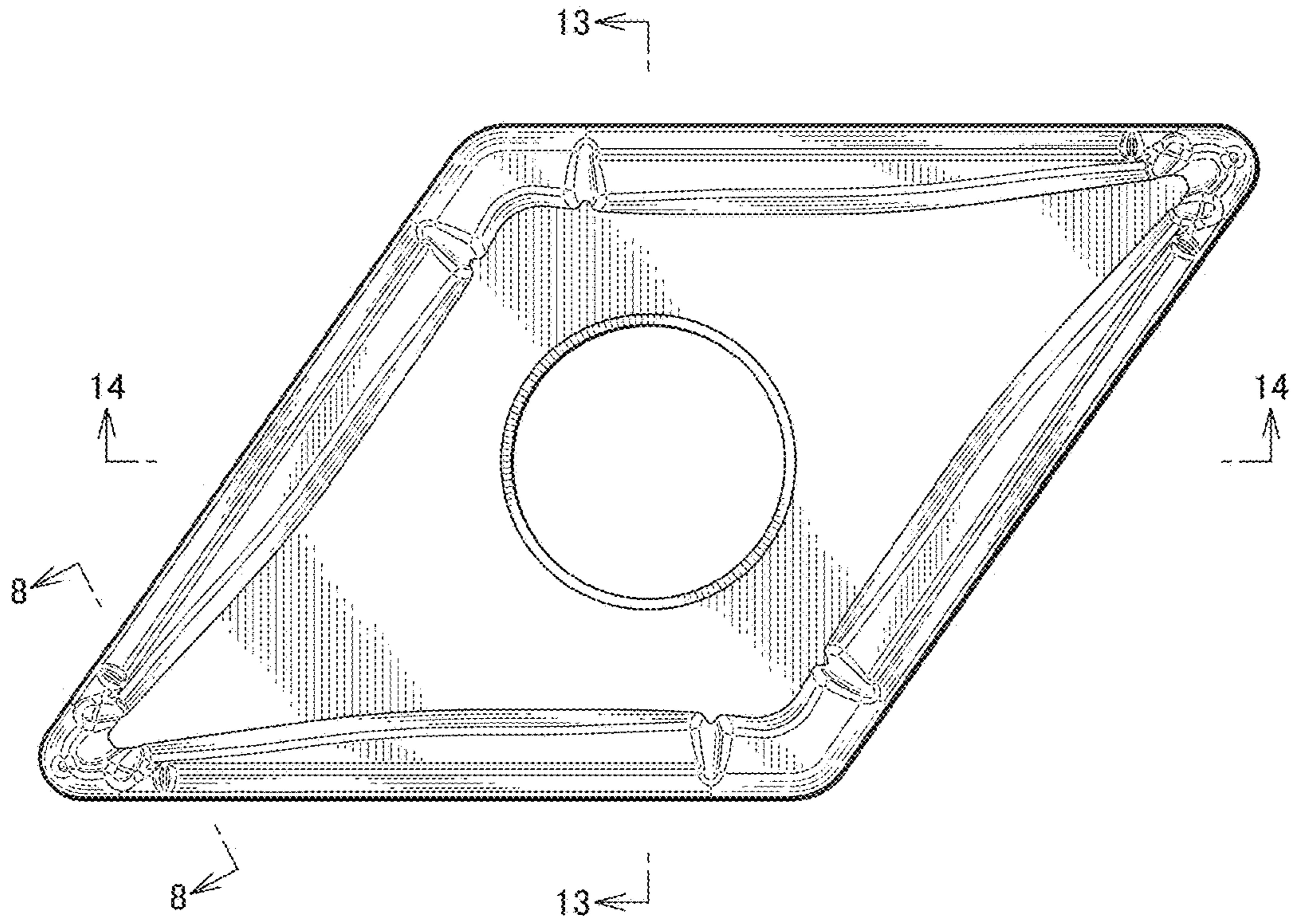

FIG.4

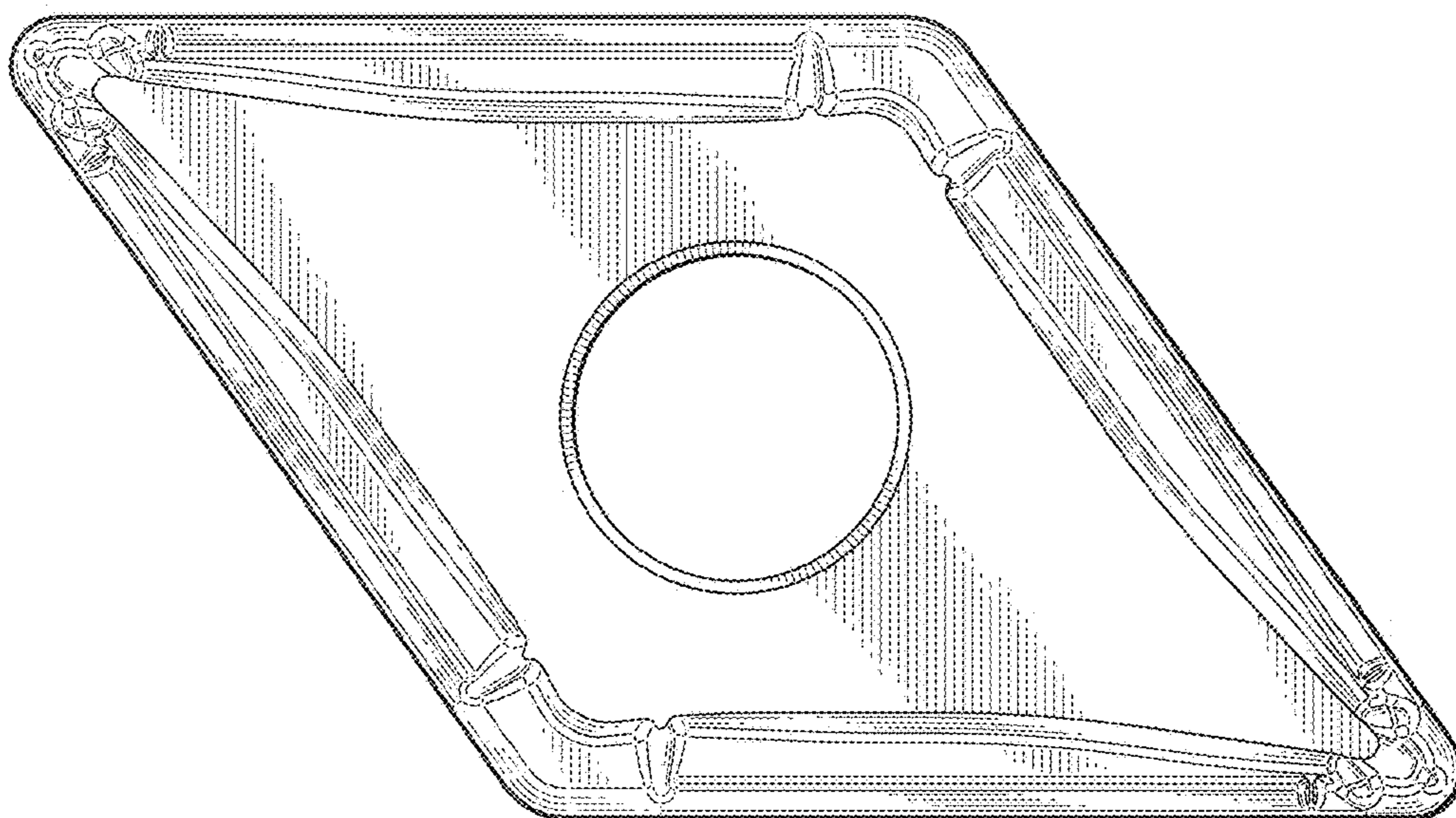

FIG.5

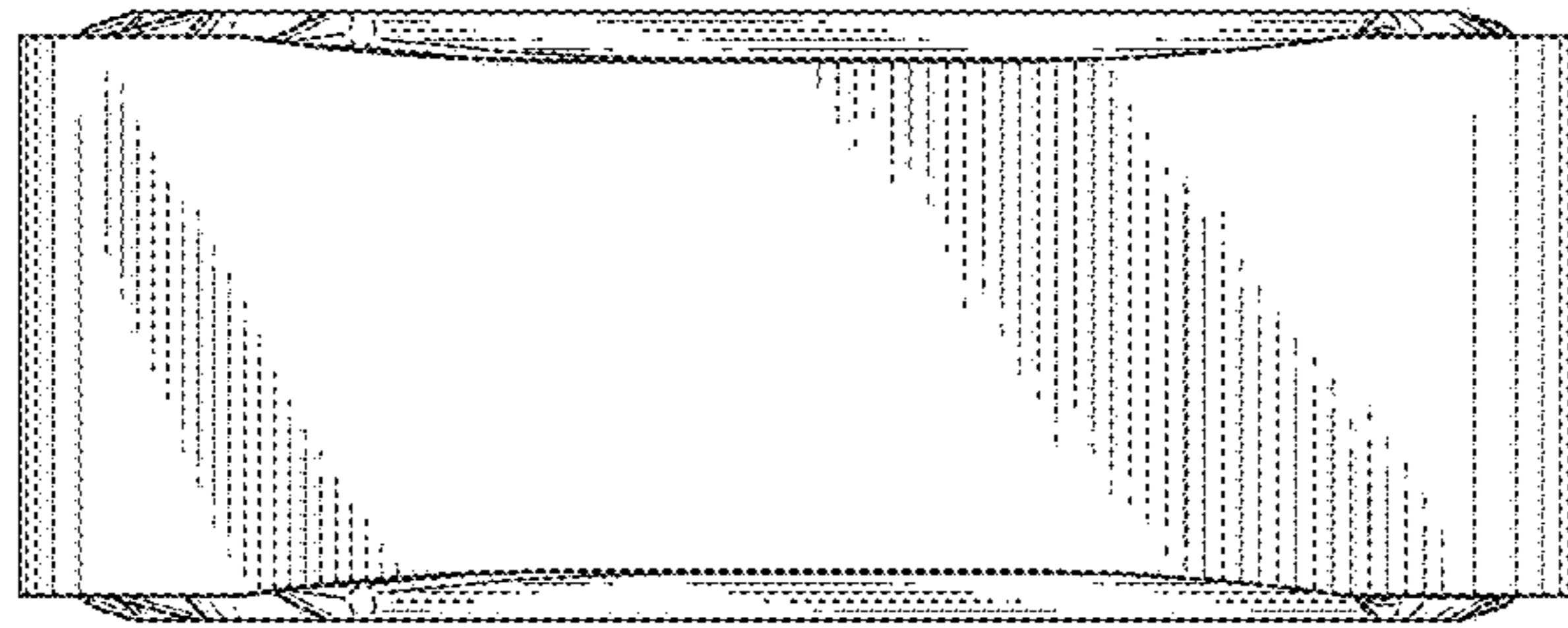

FIG.6

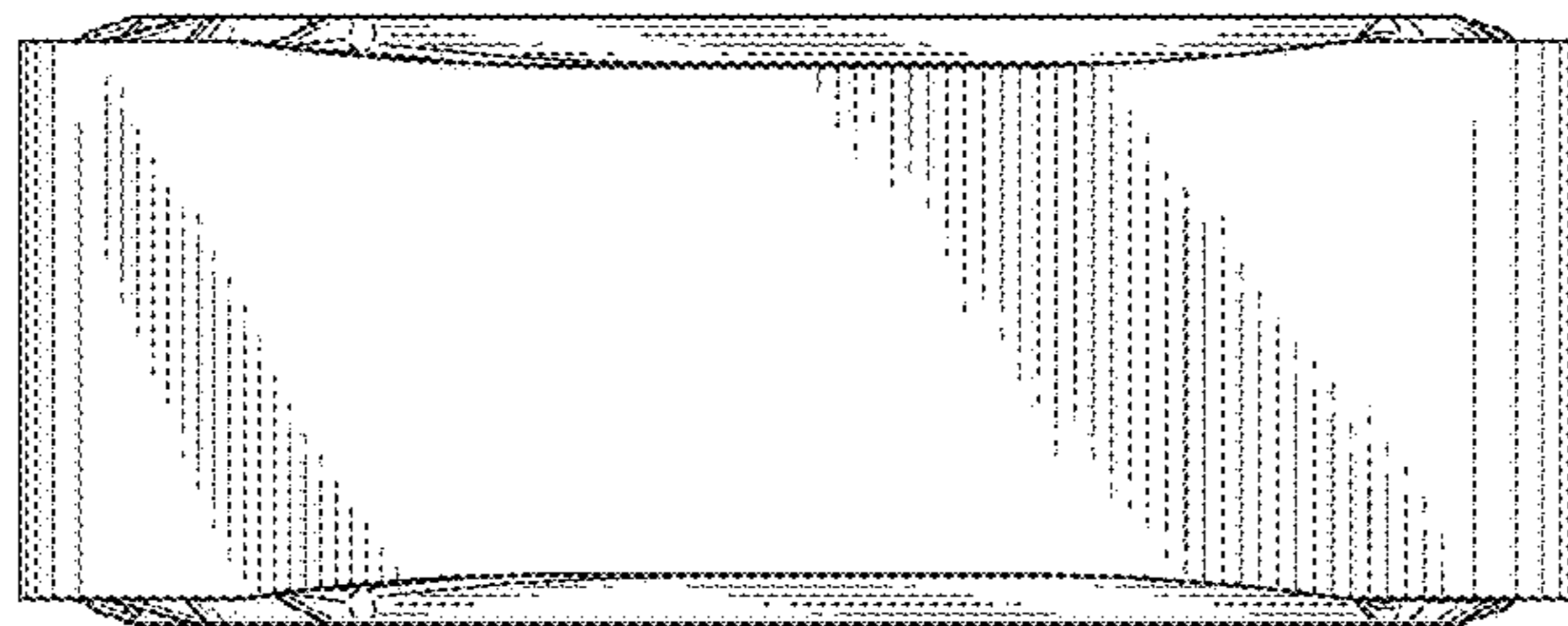

FIG.7

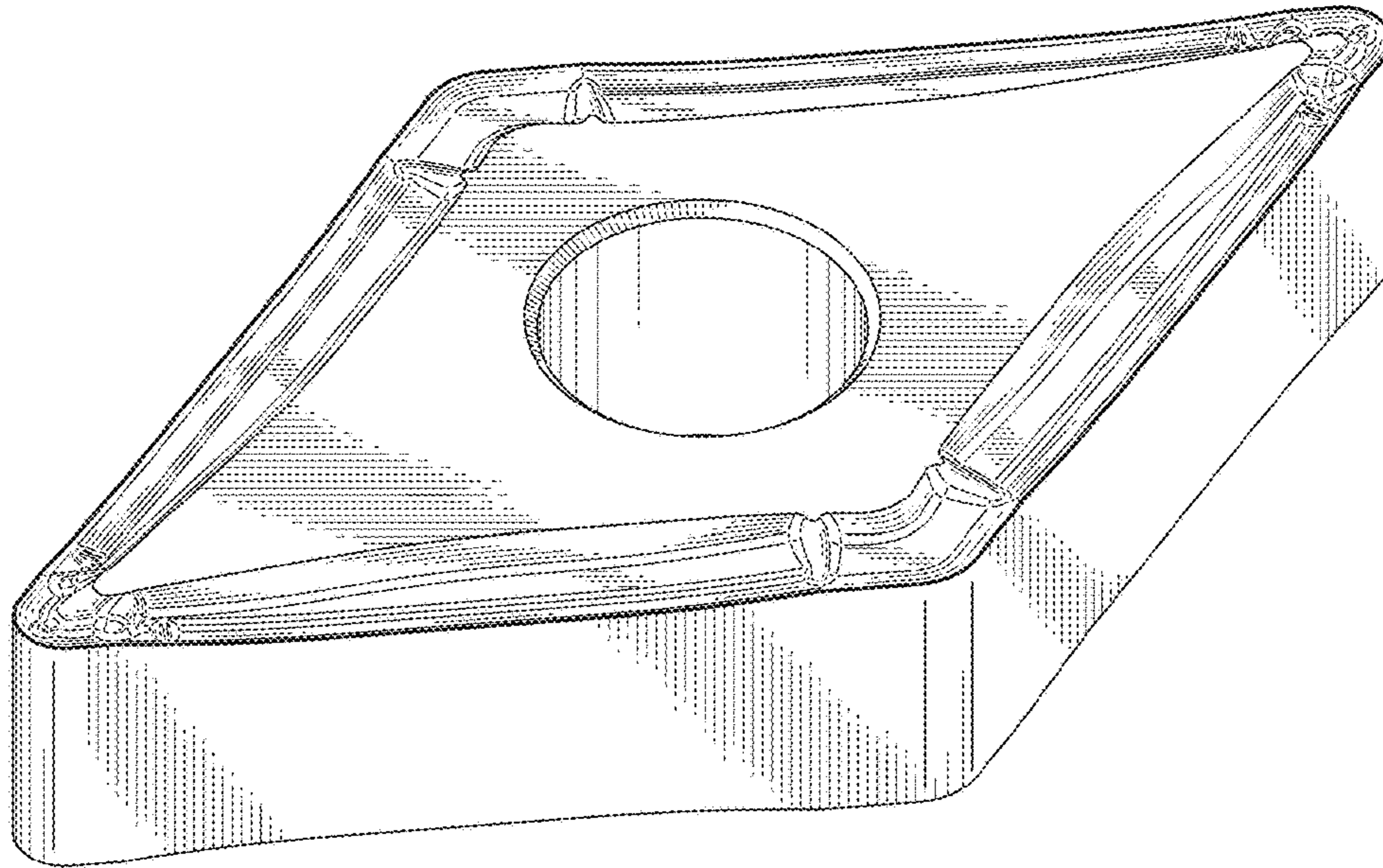

FIG.8

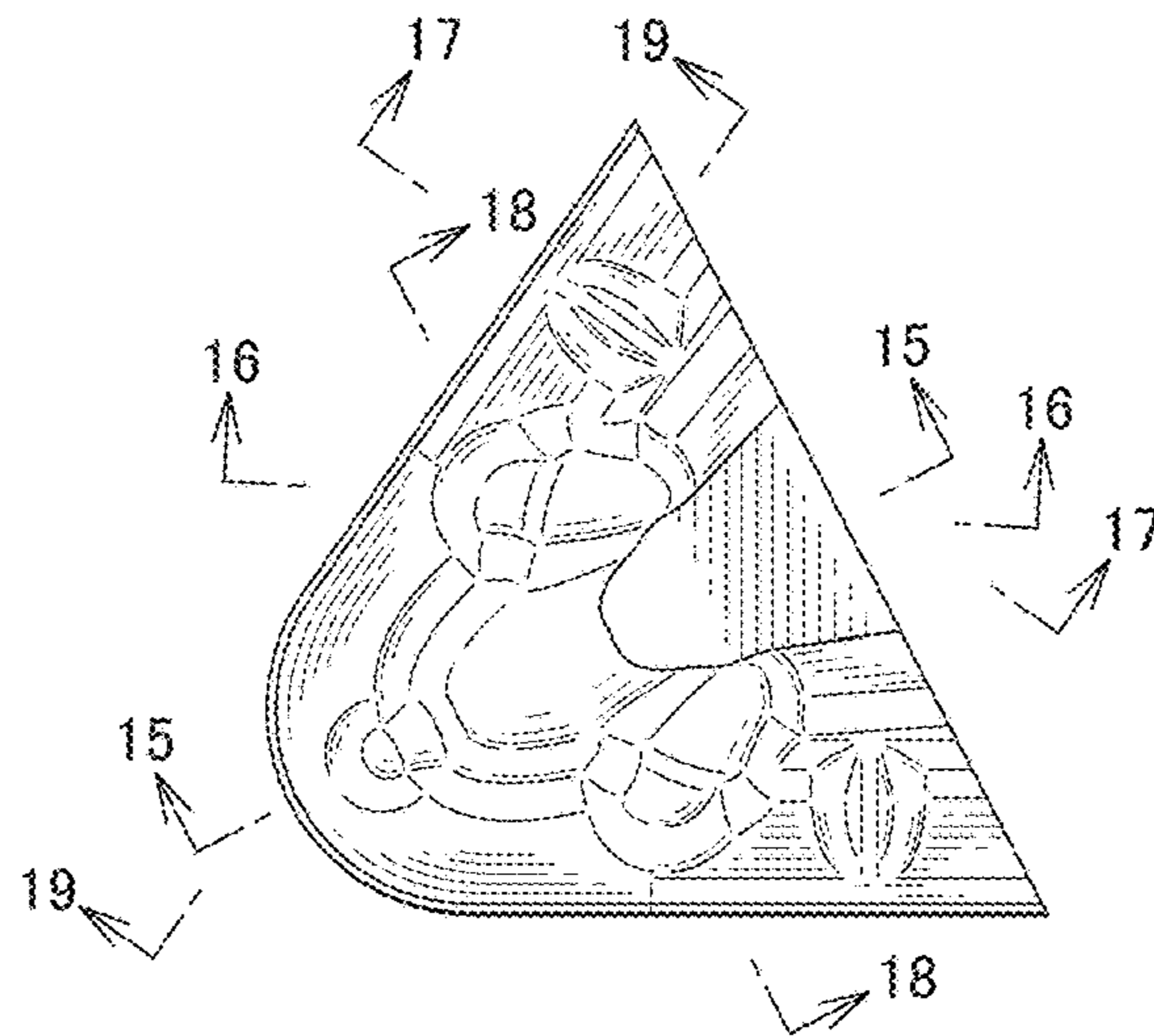



FIG.9

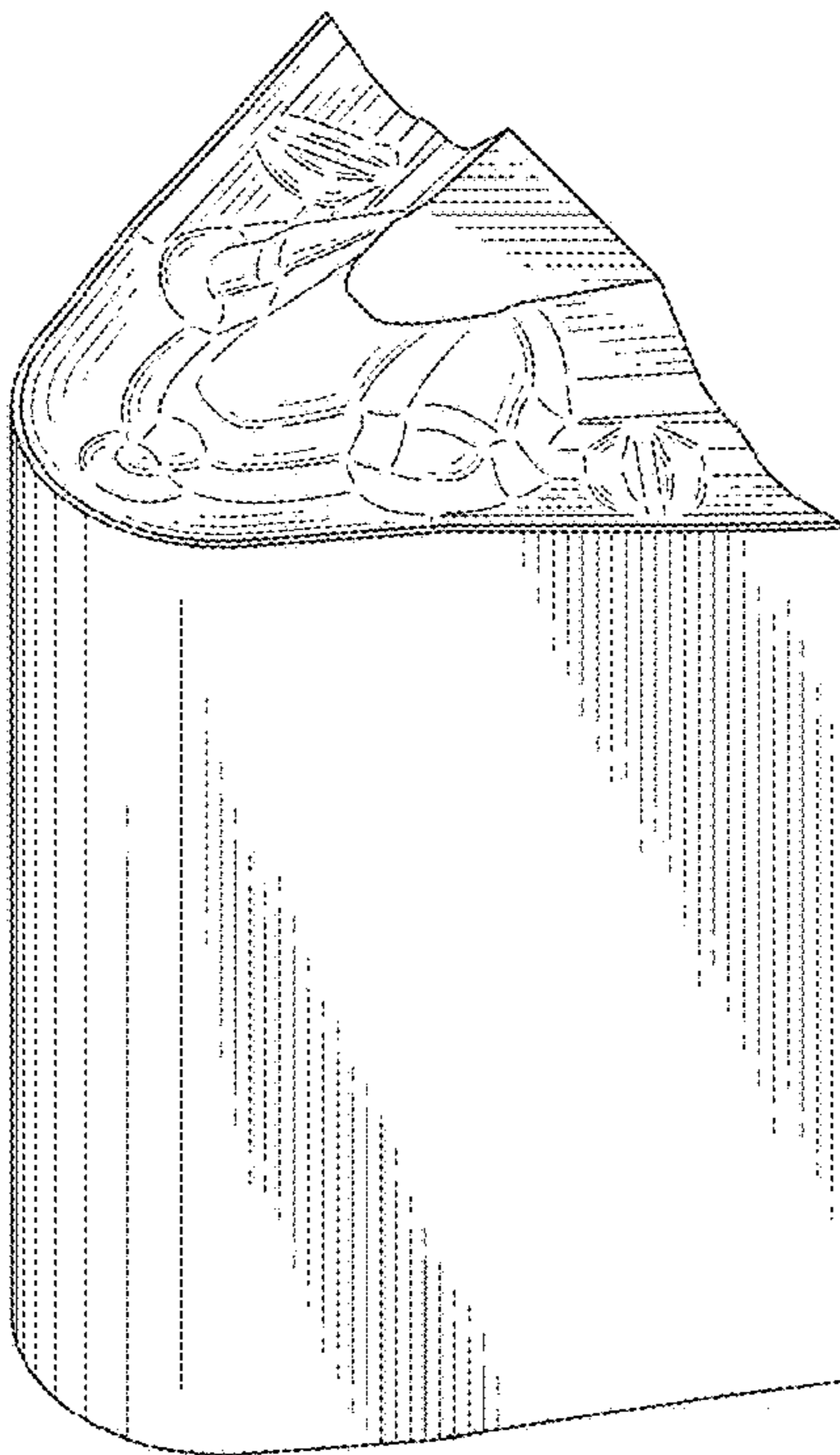

FIG.10

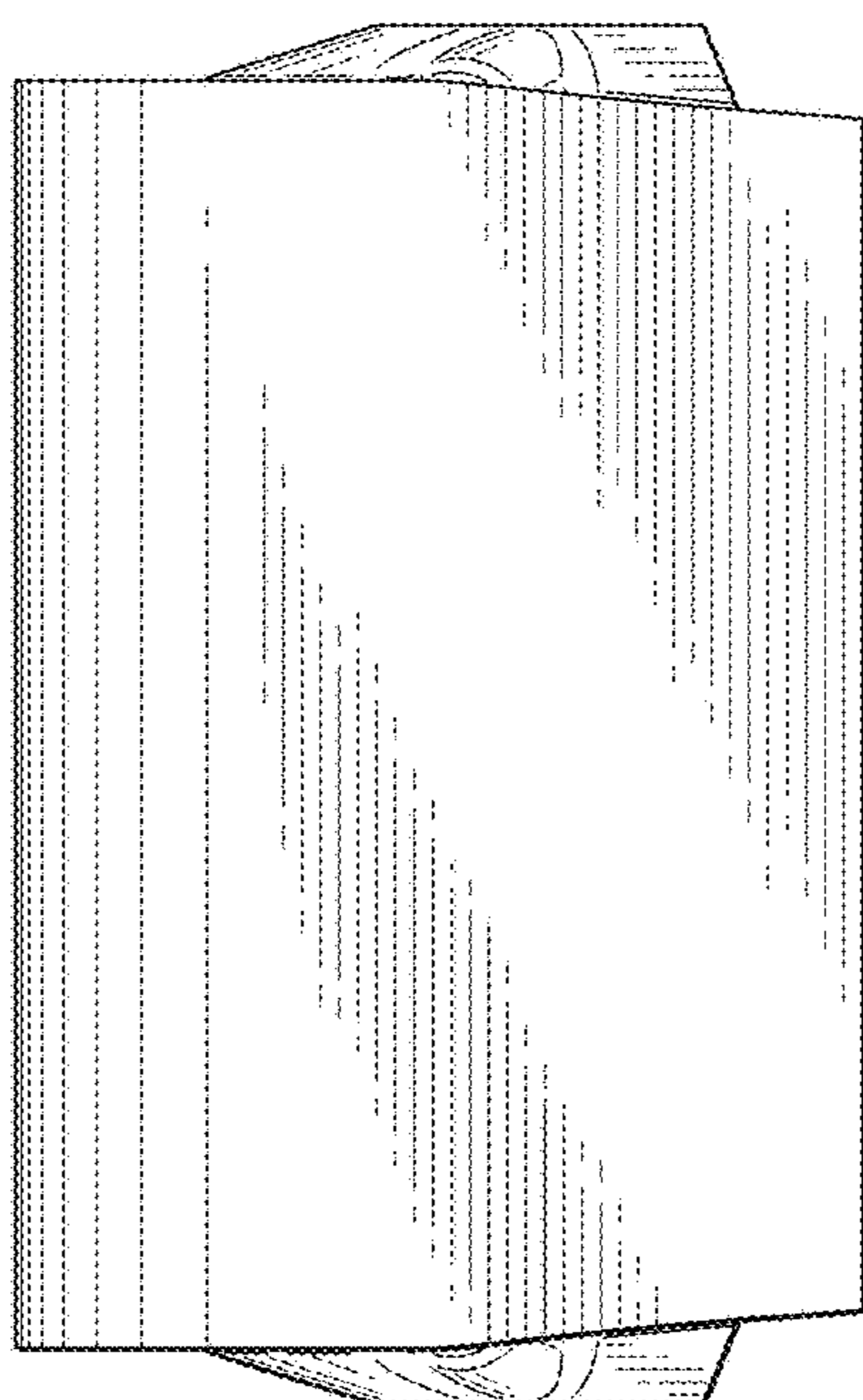

FIG.11

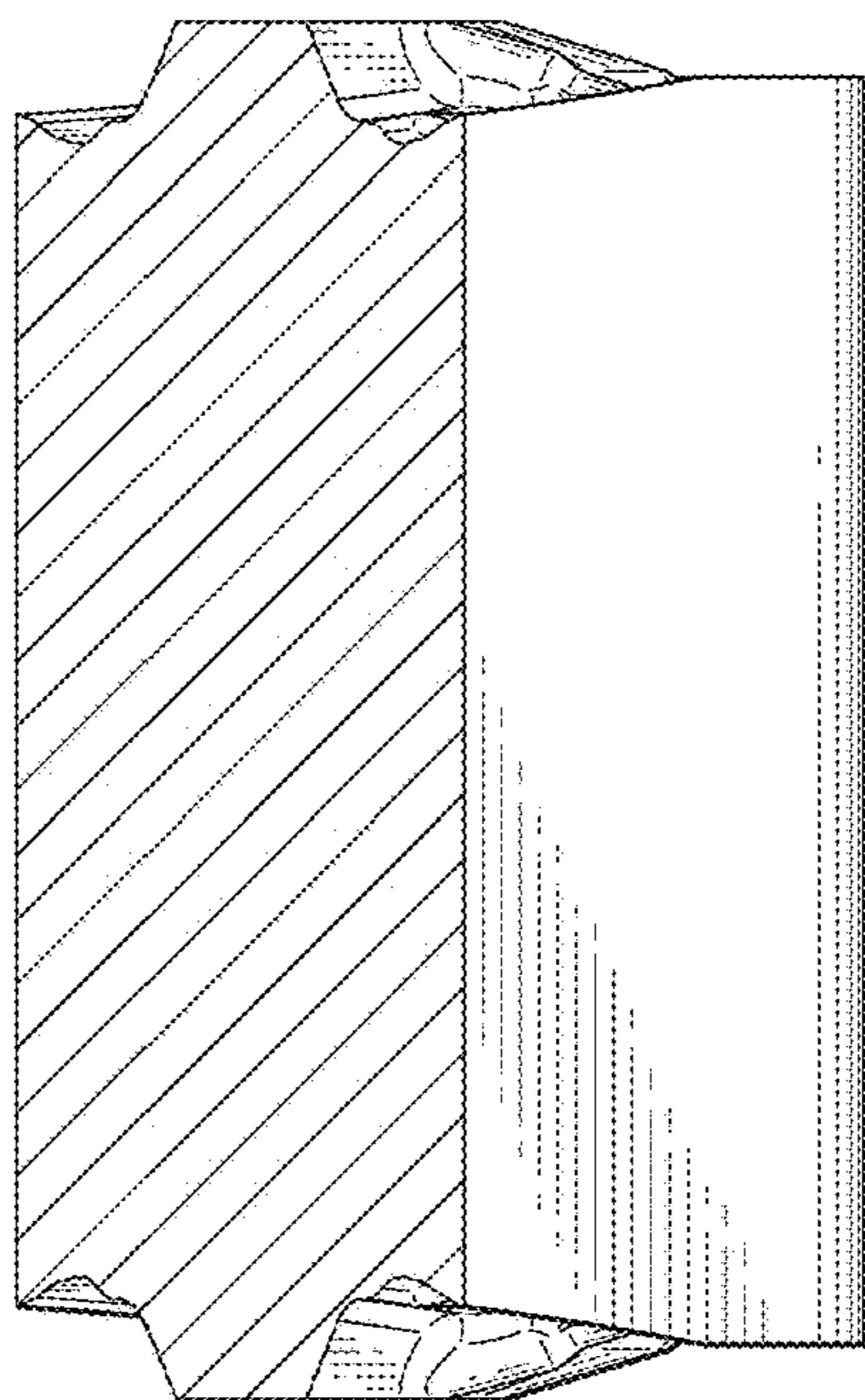

FIG.12

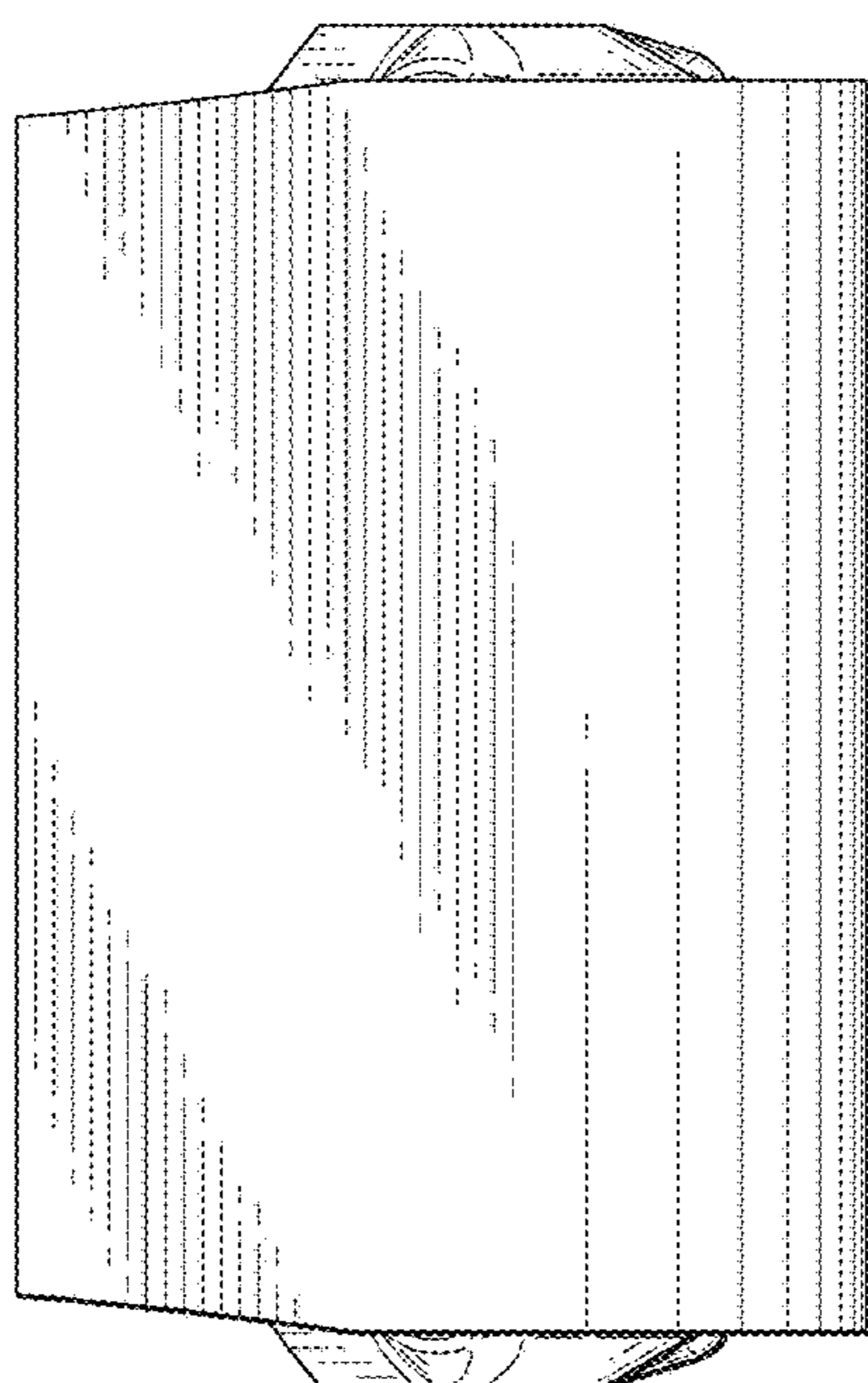



FIG.13

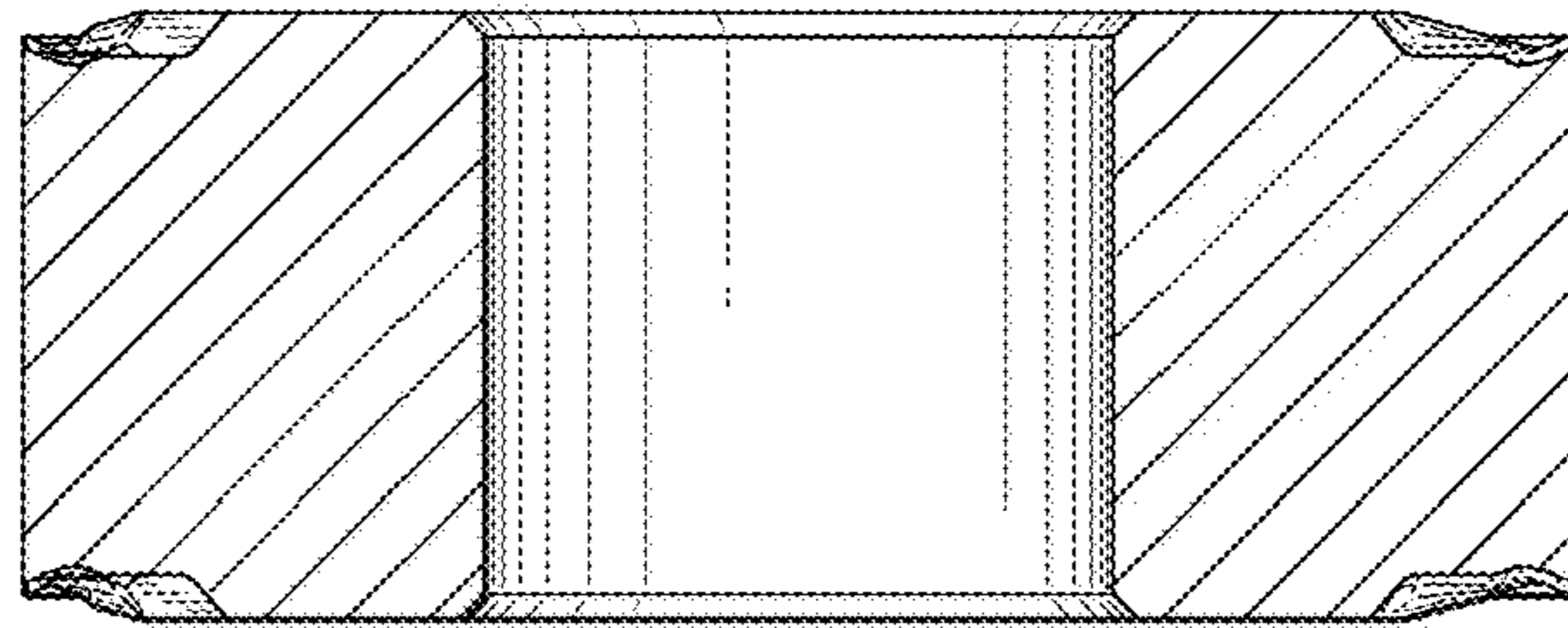

FIG.14

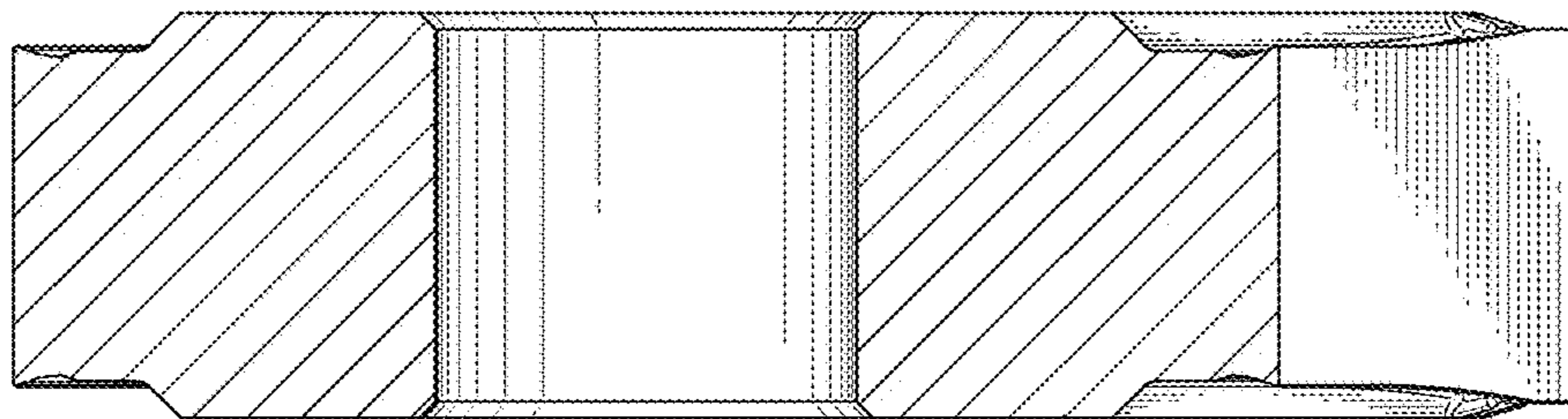

FIG.15

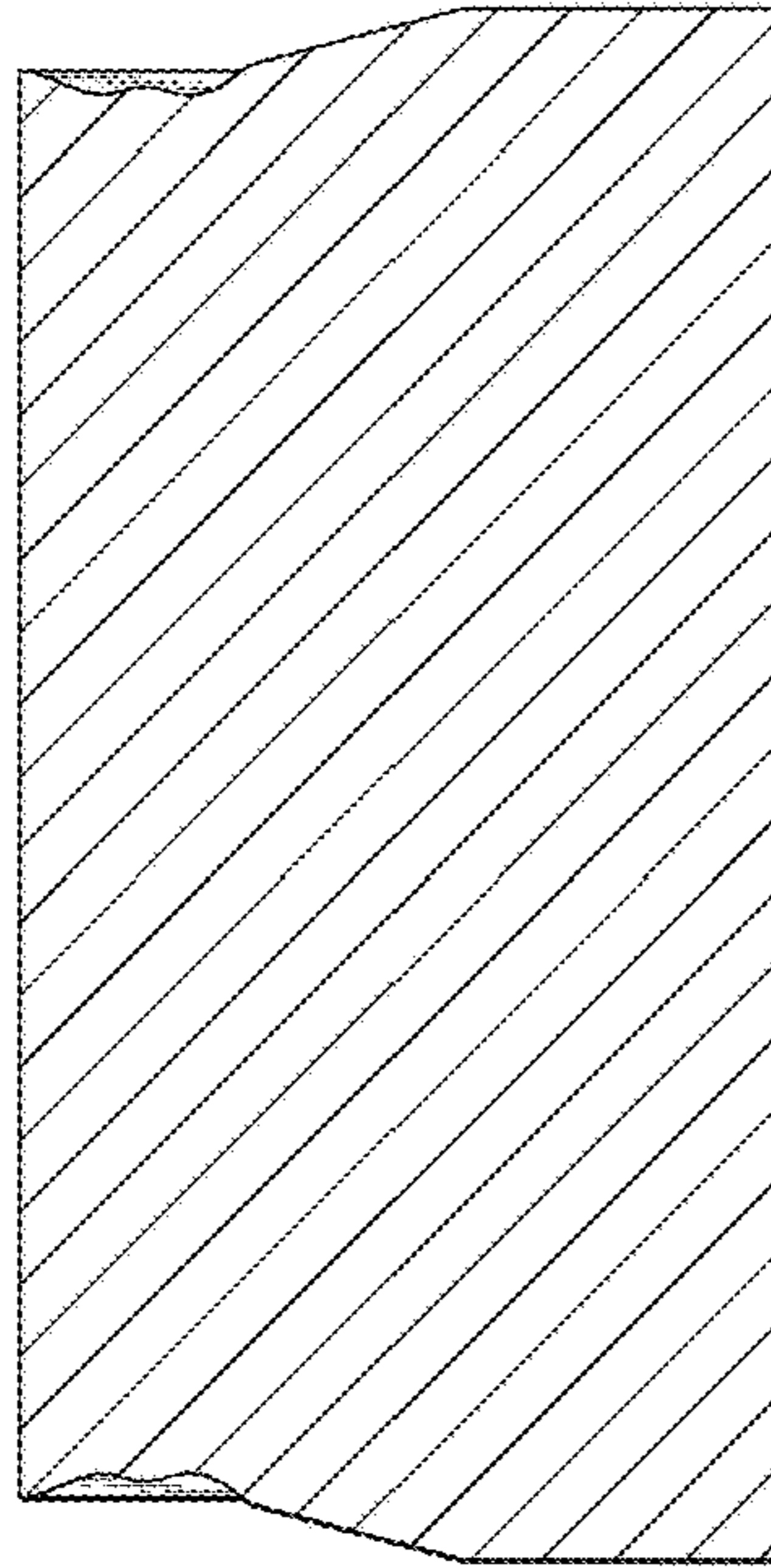

FIG.16

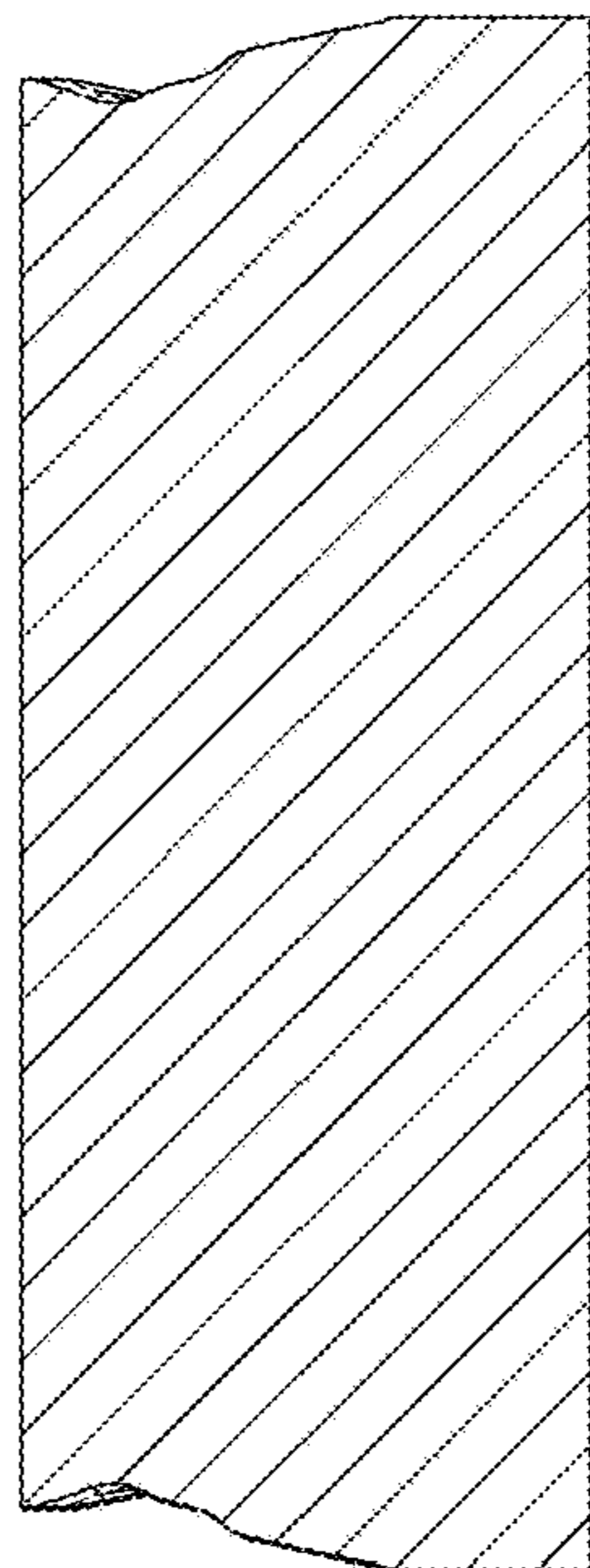

FIG.17

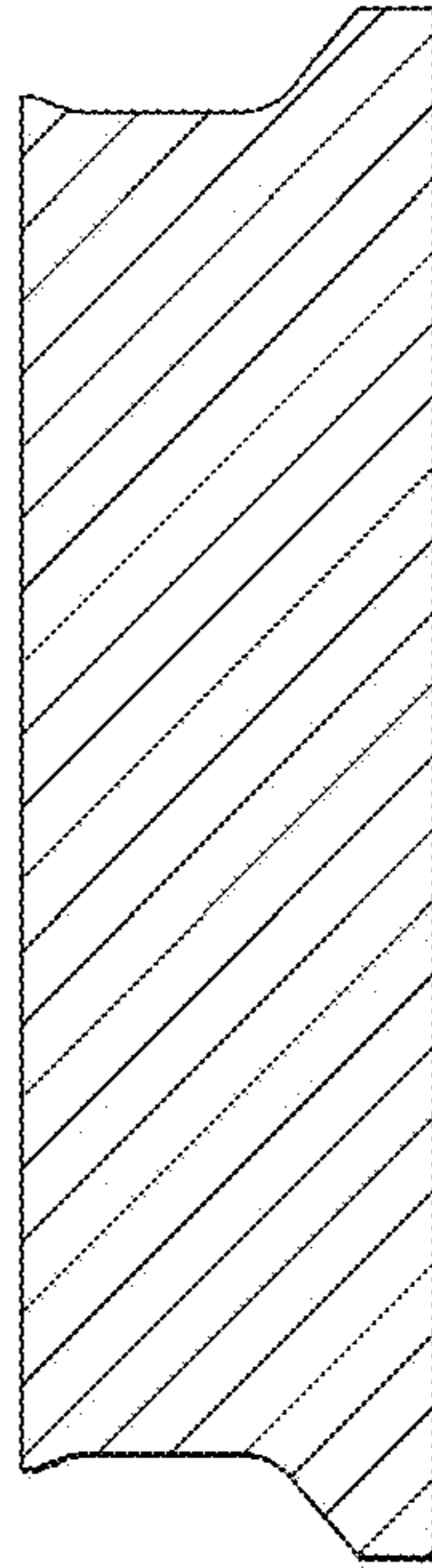

FIG.18

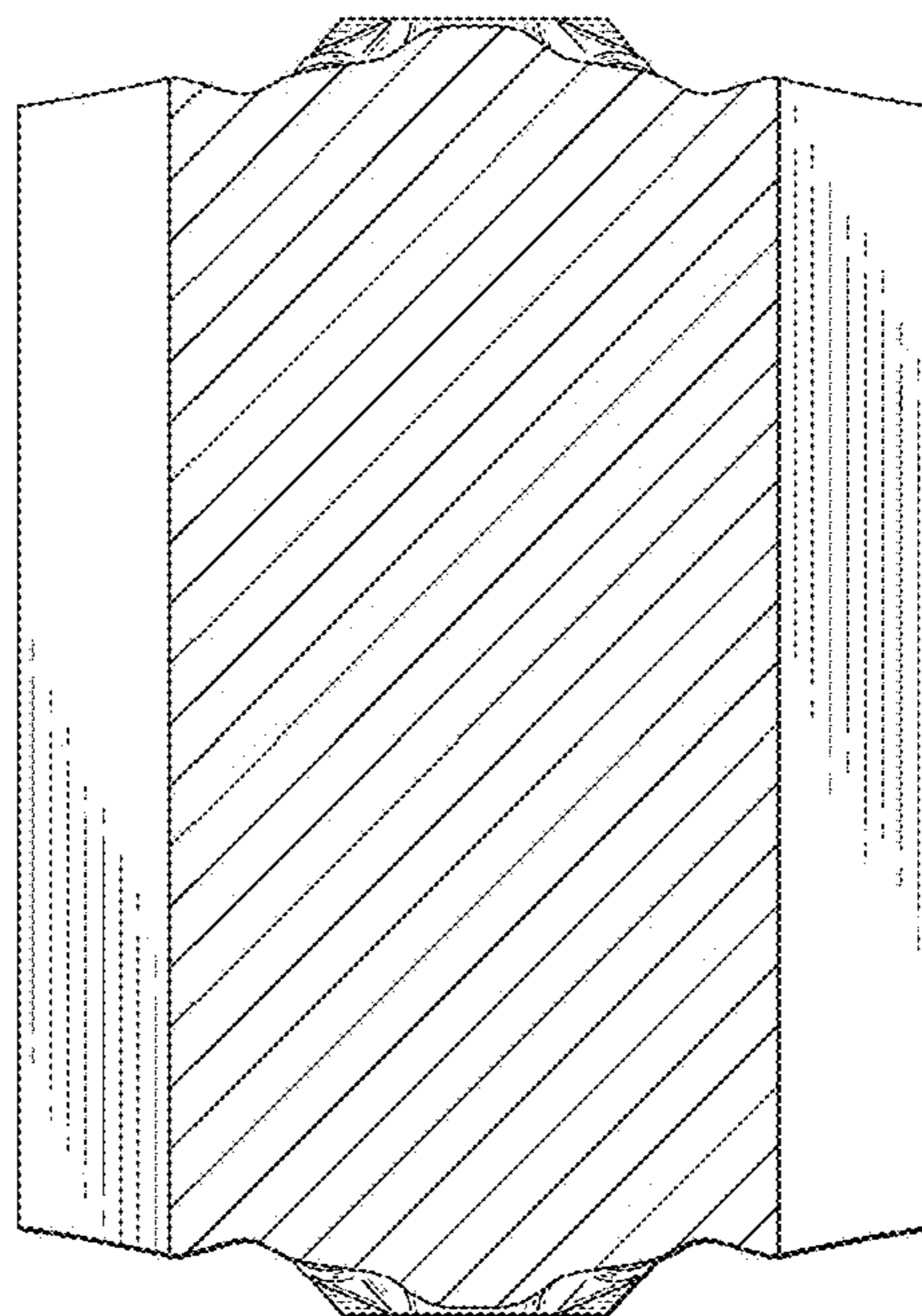



FIG.19

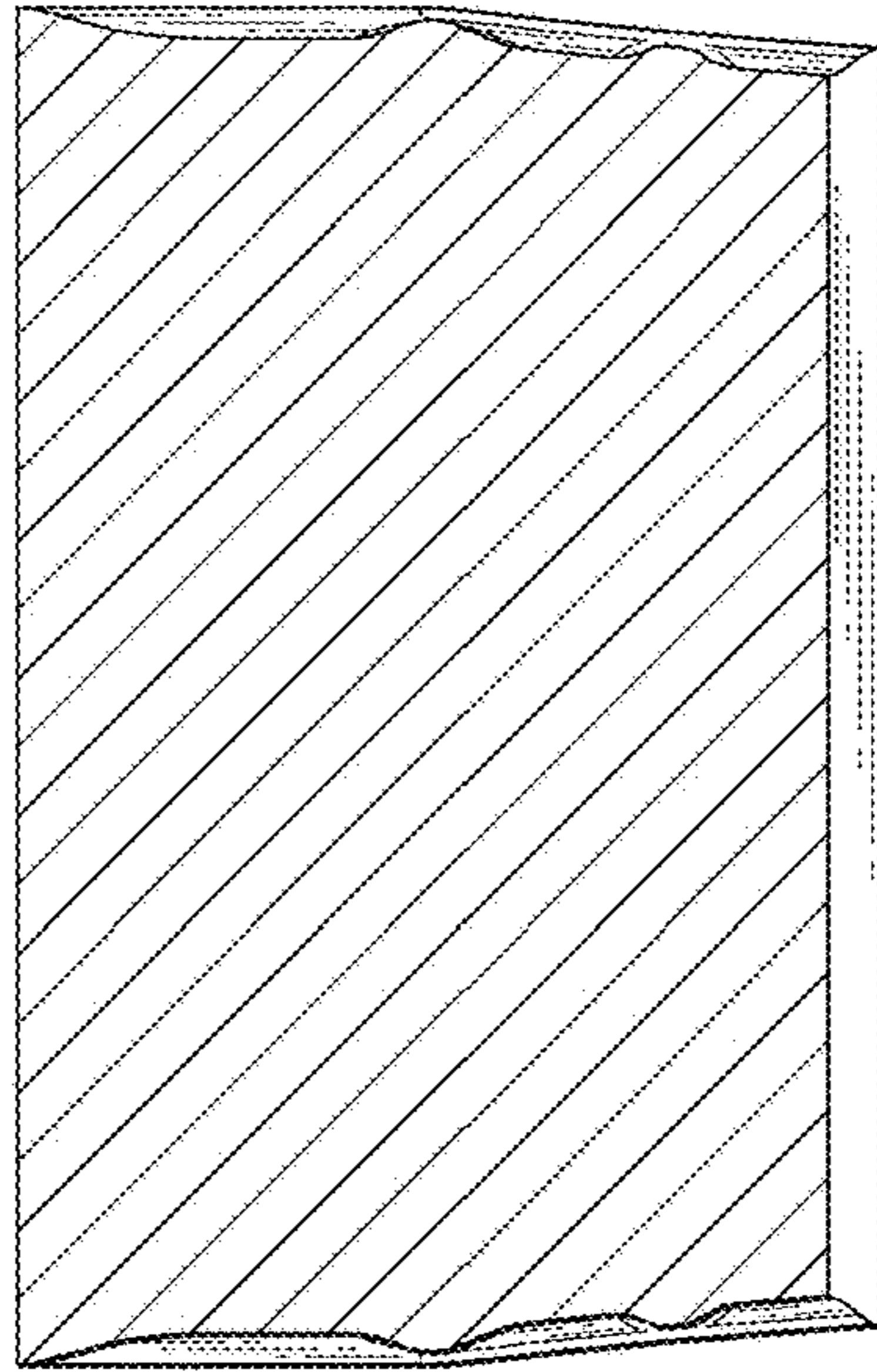

FIG.20

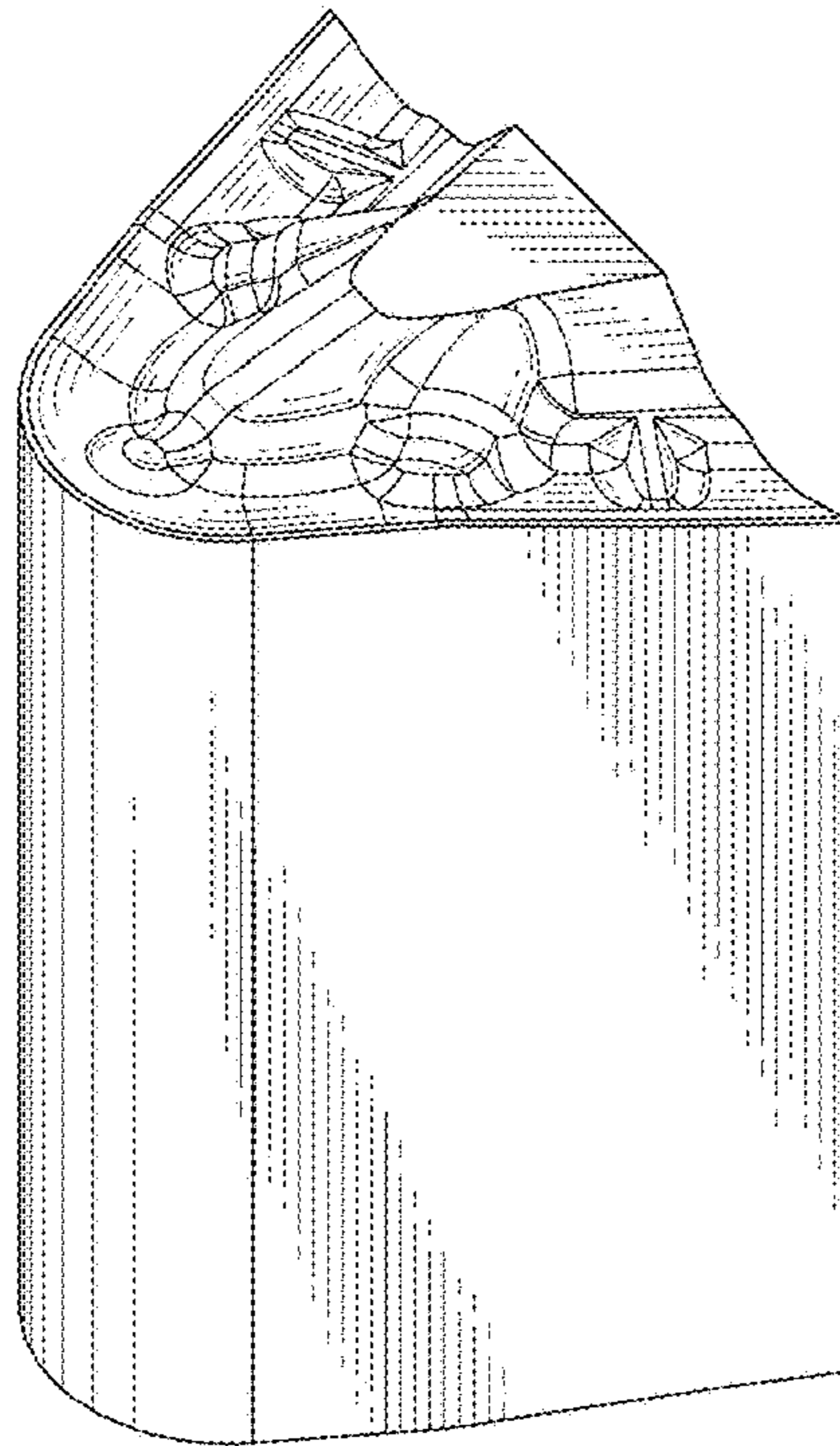

FIG.21

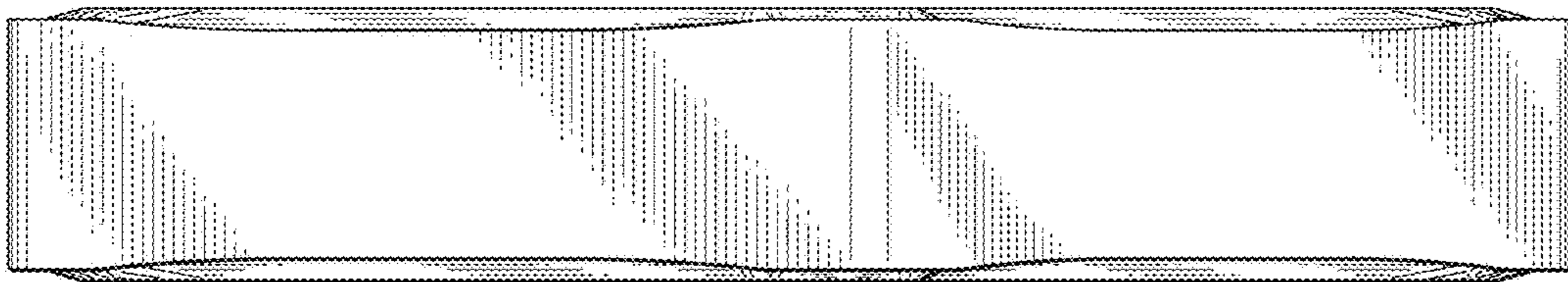

FIG.22

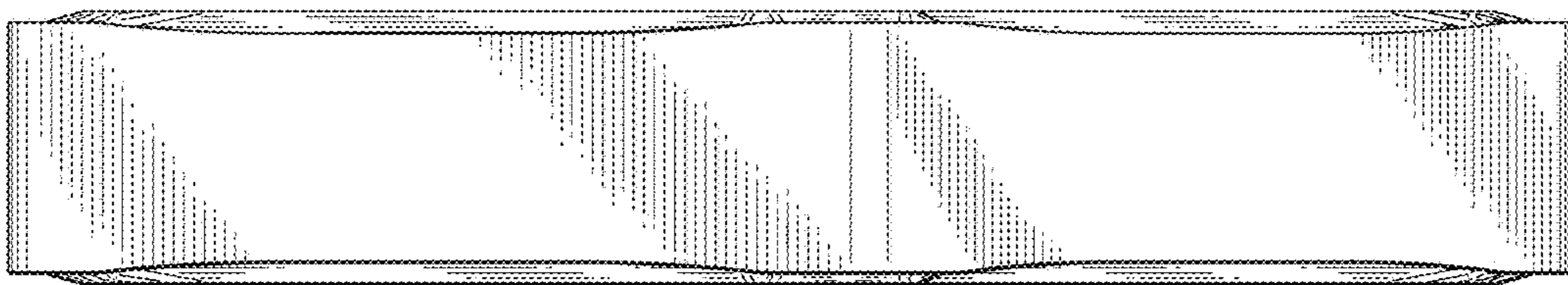

FIG.23

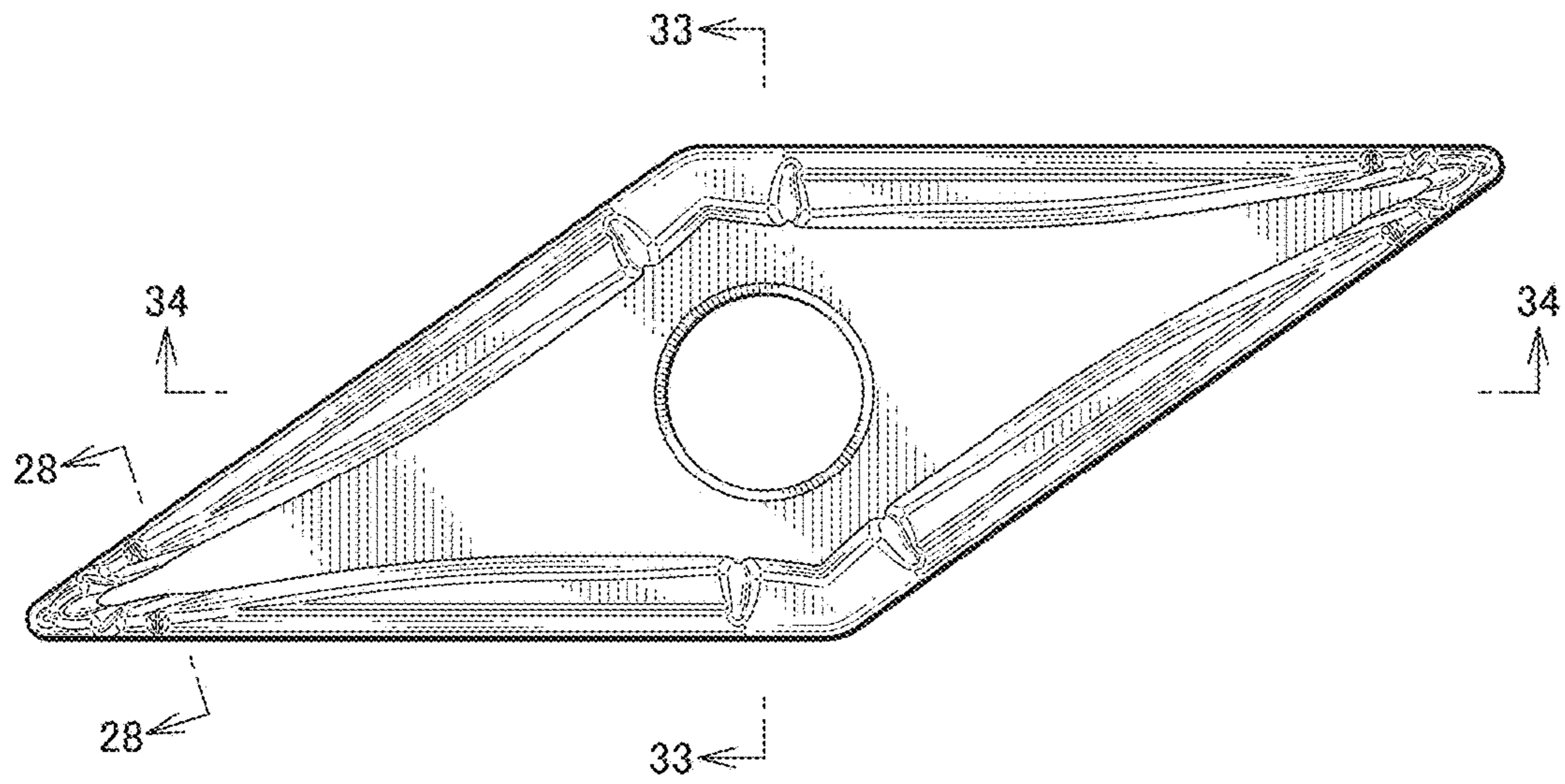

FIG.24

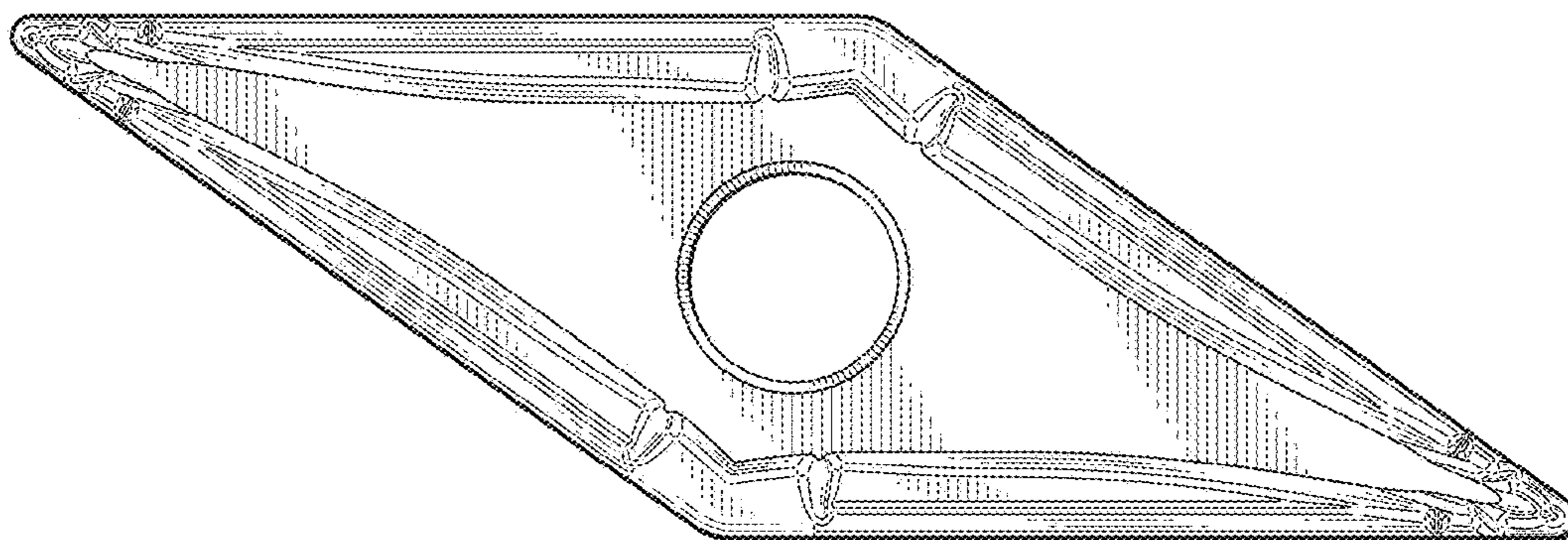



FIG.25

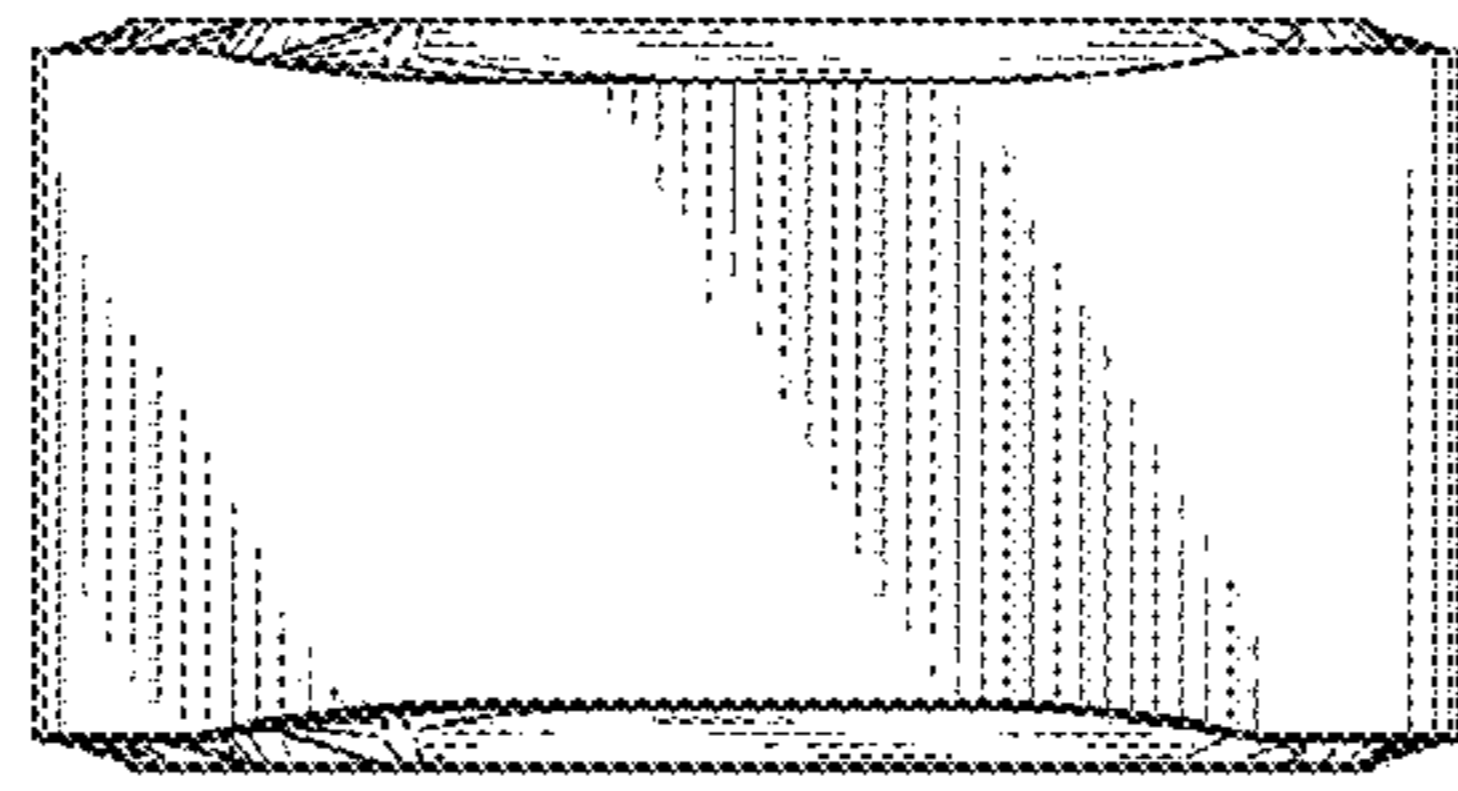

FIG.26

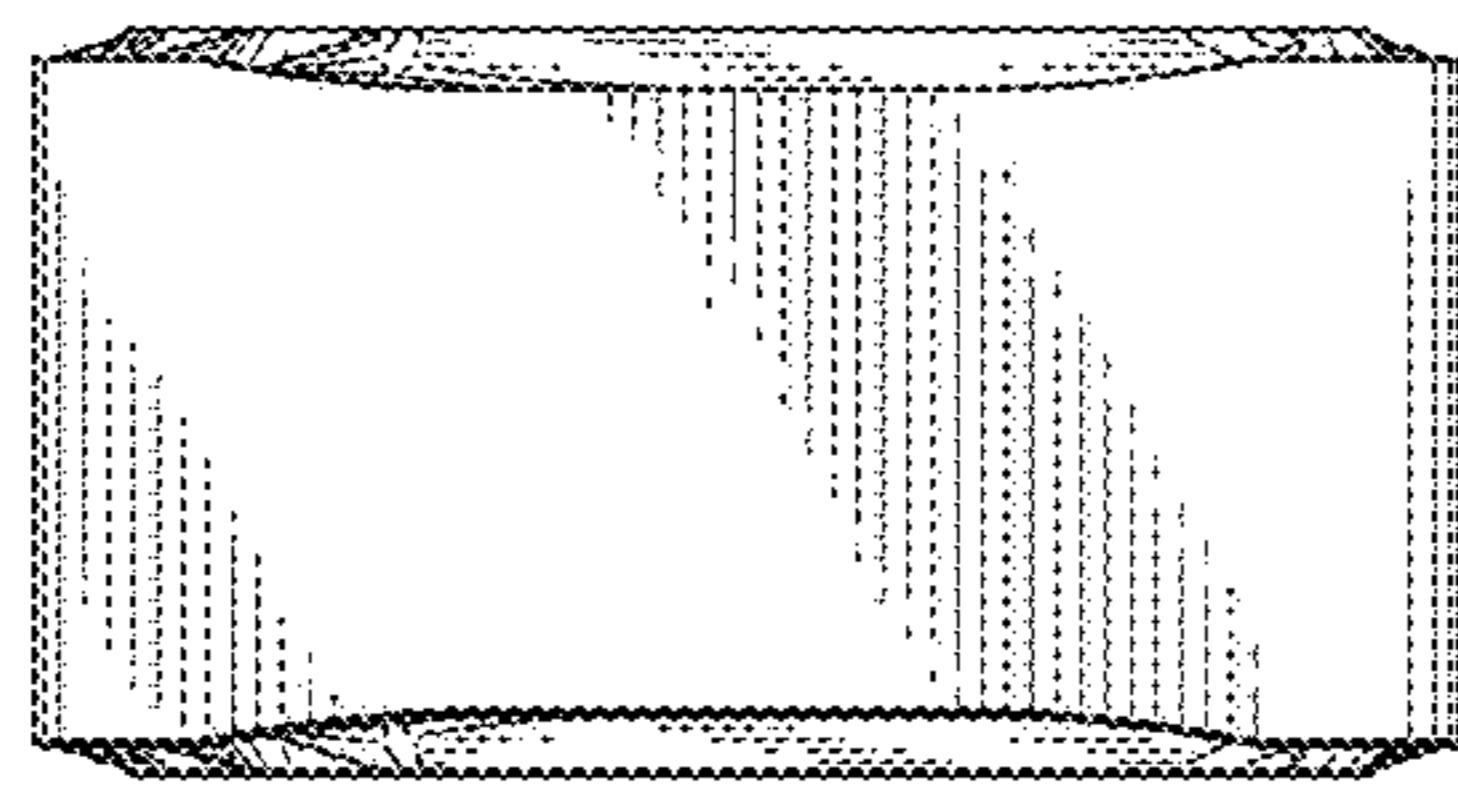

FIG.27

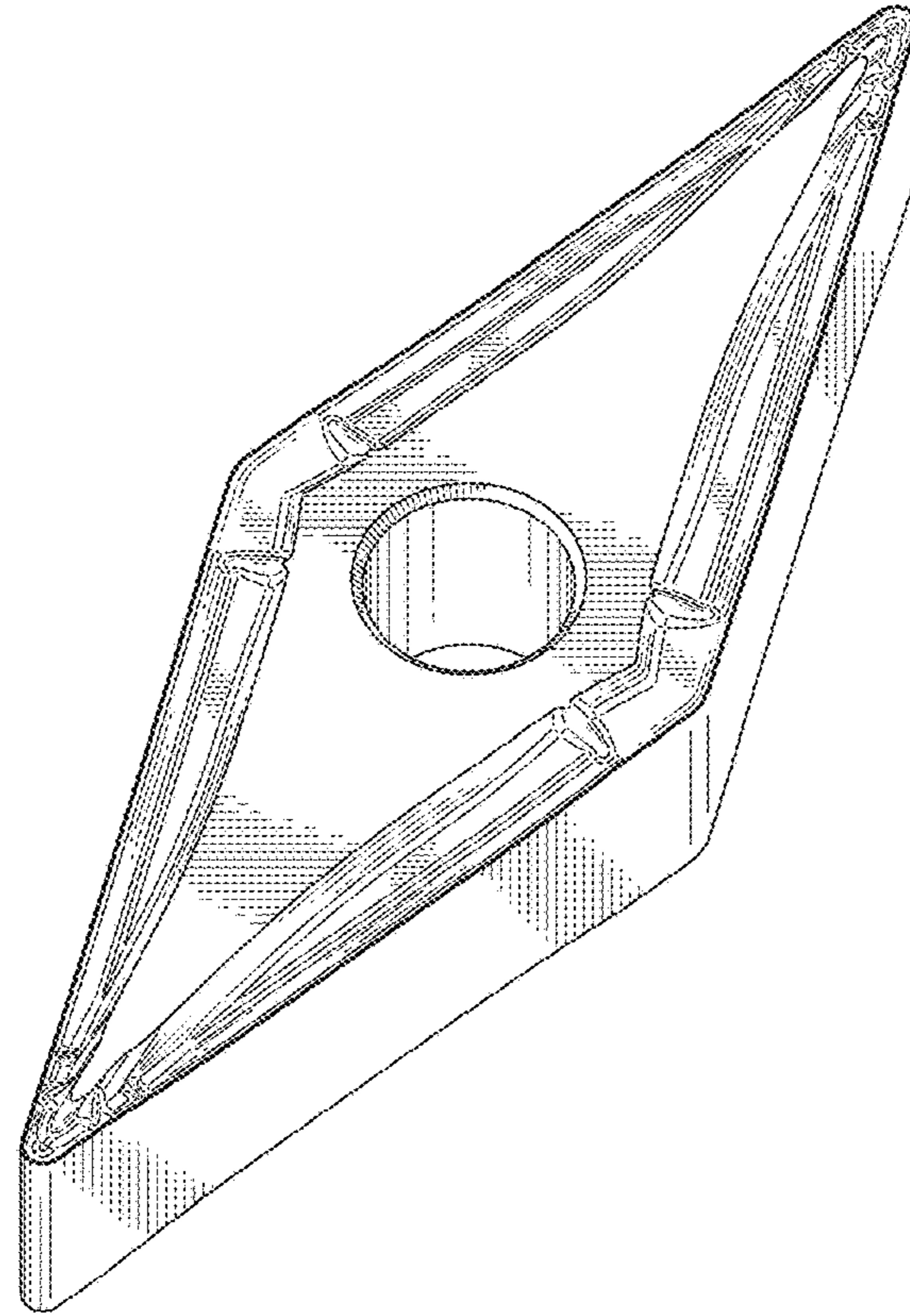

FIG.28

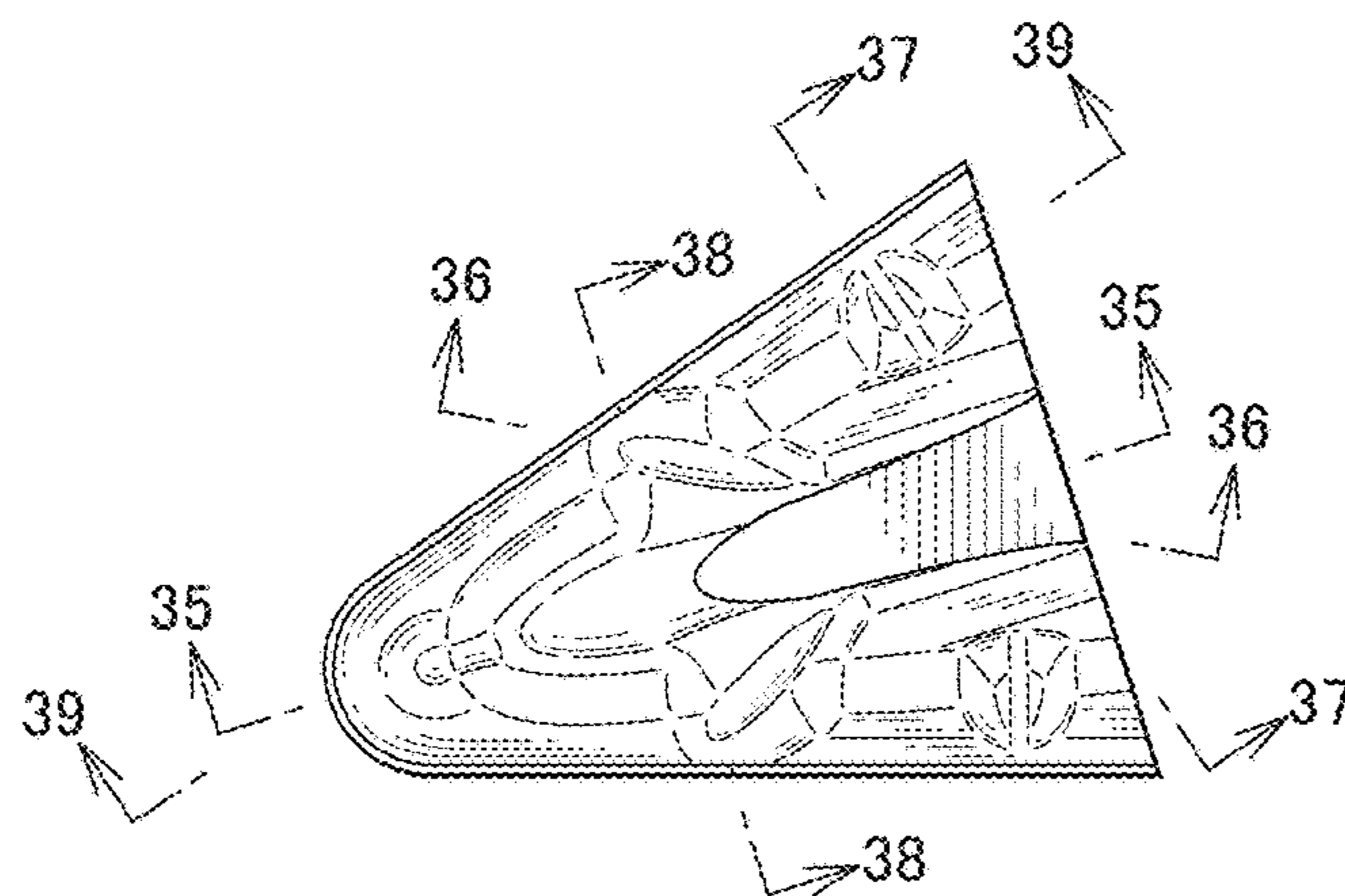

FIG.29

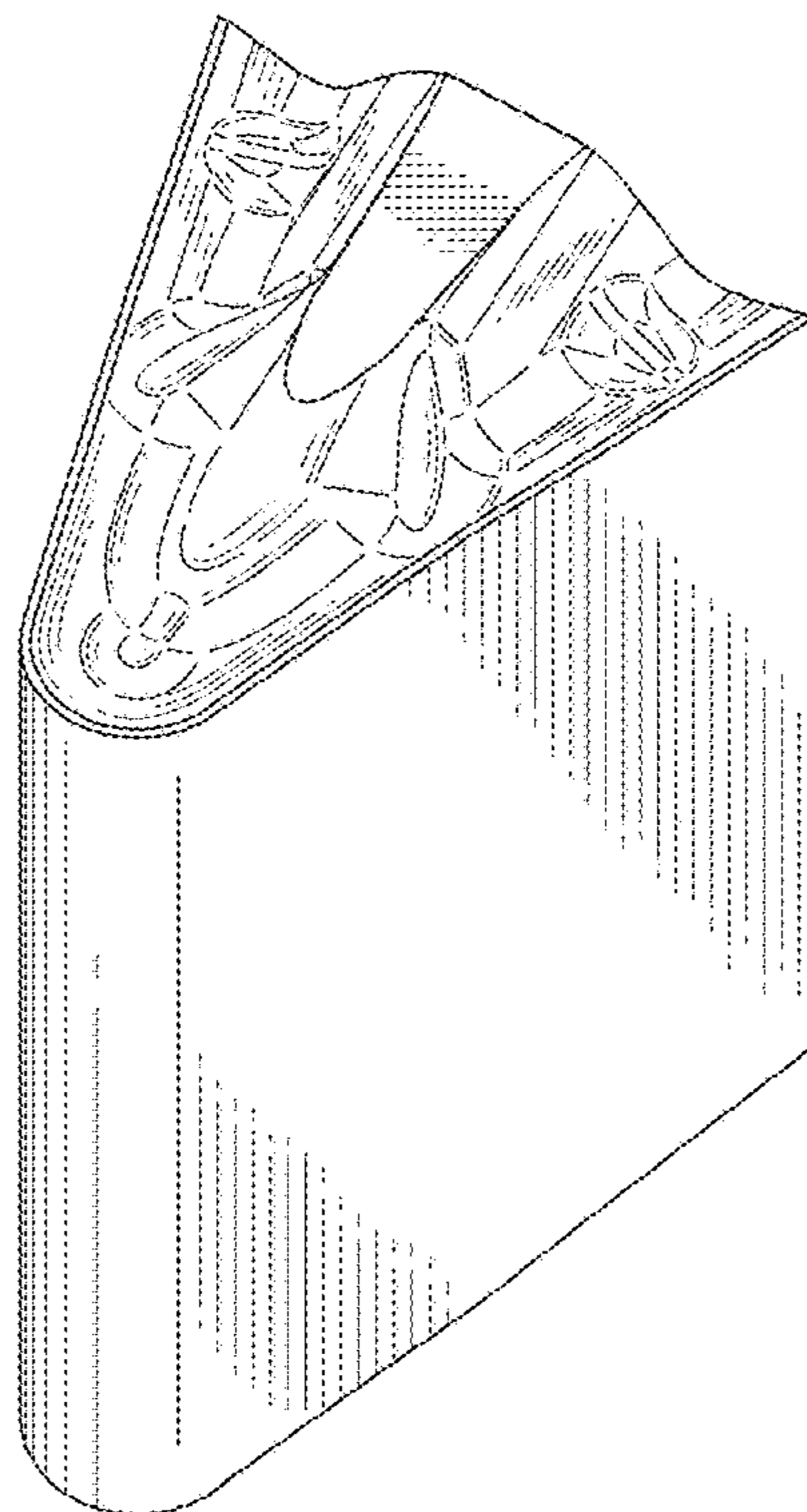

FIG.30

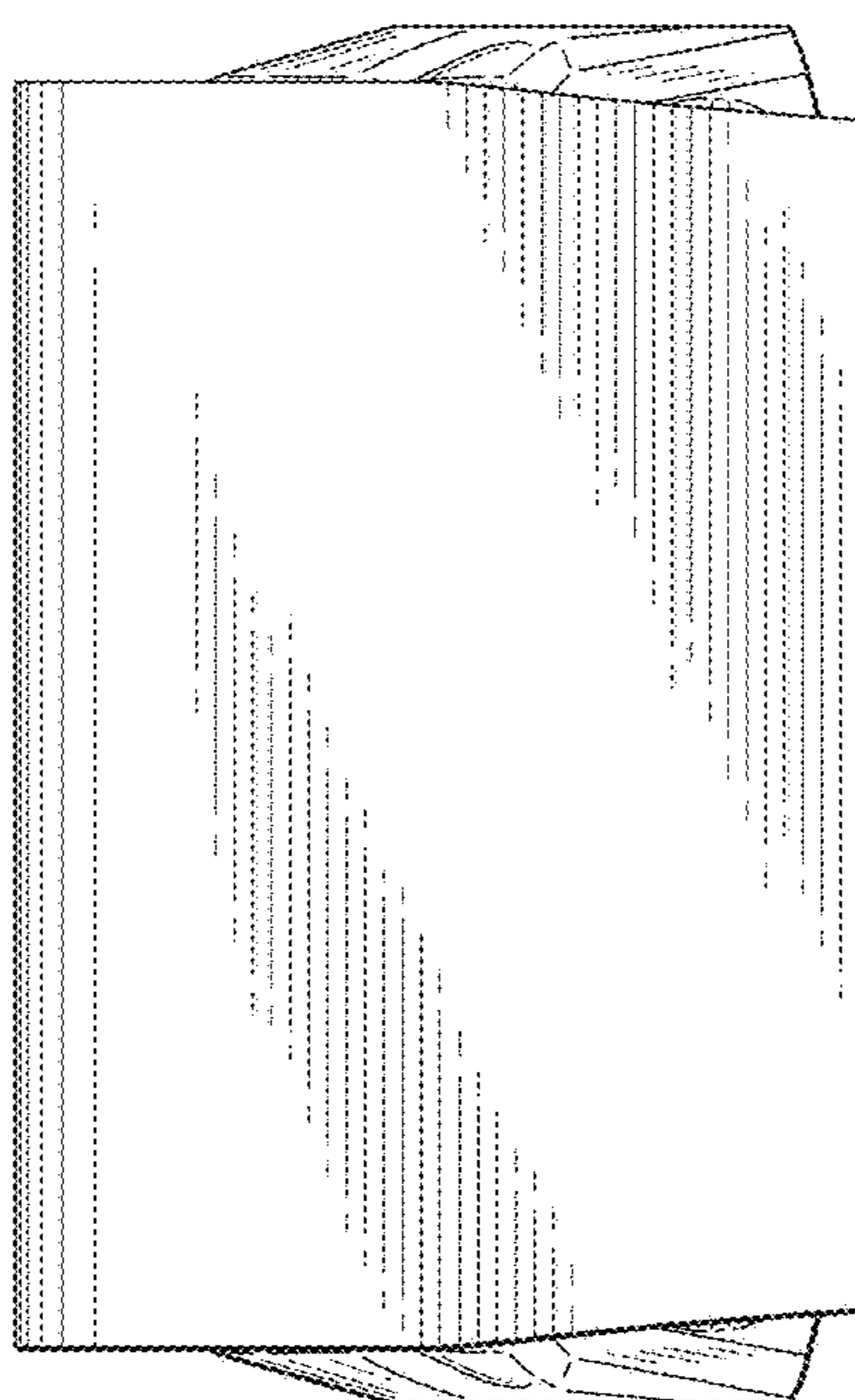



FIG.31

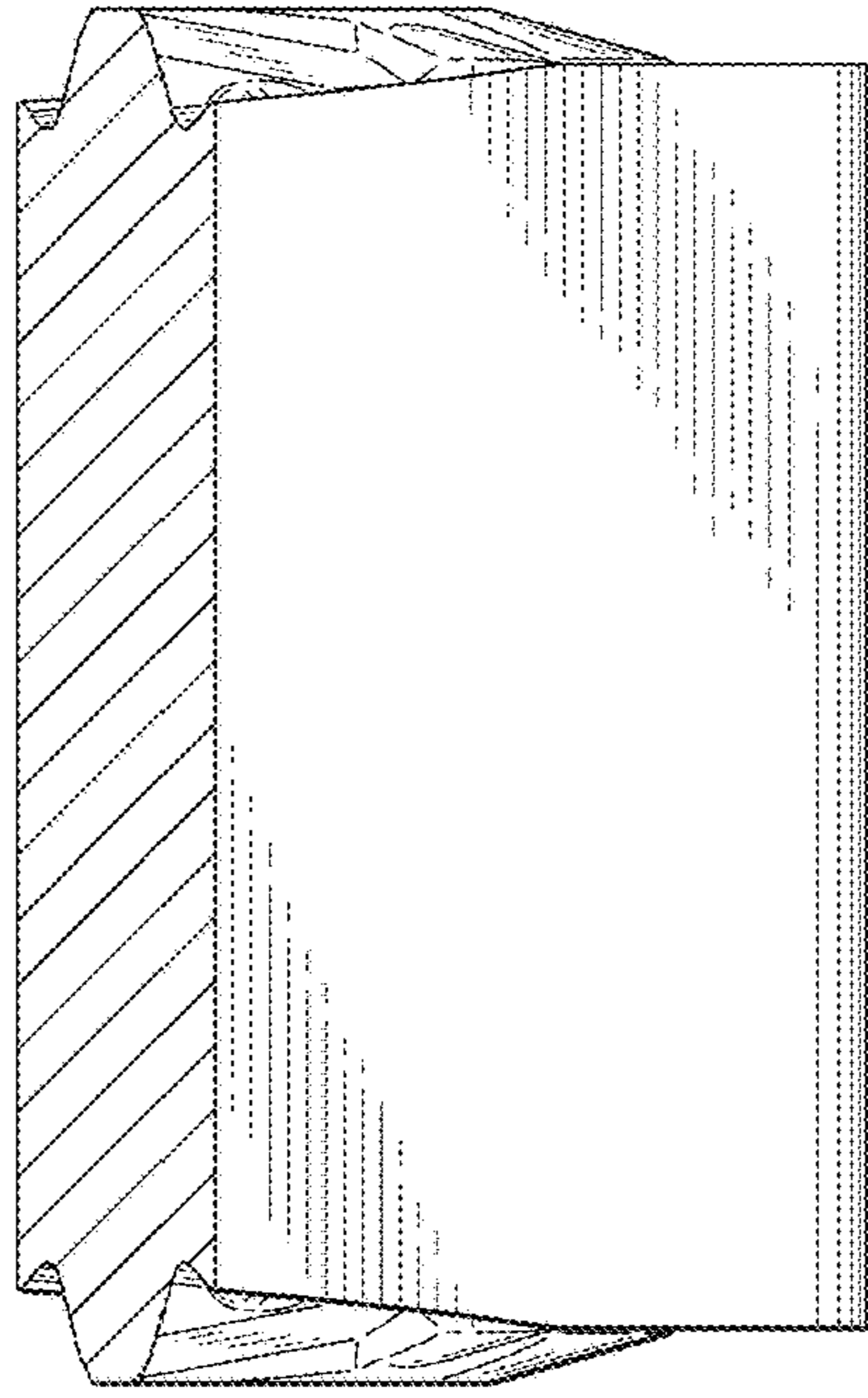

FIG.32

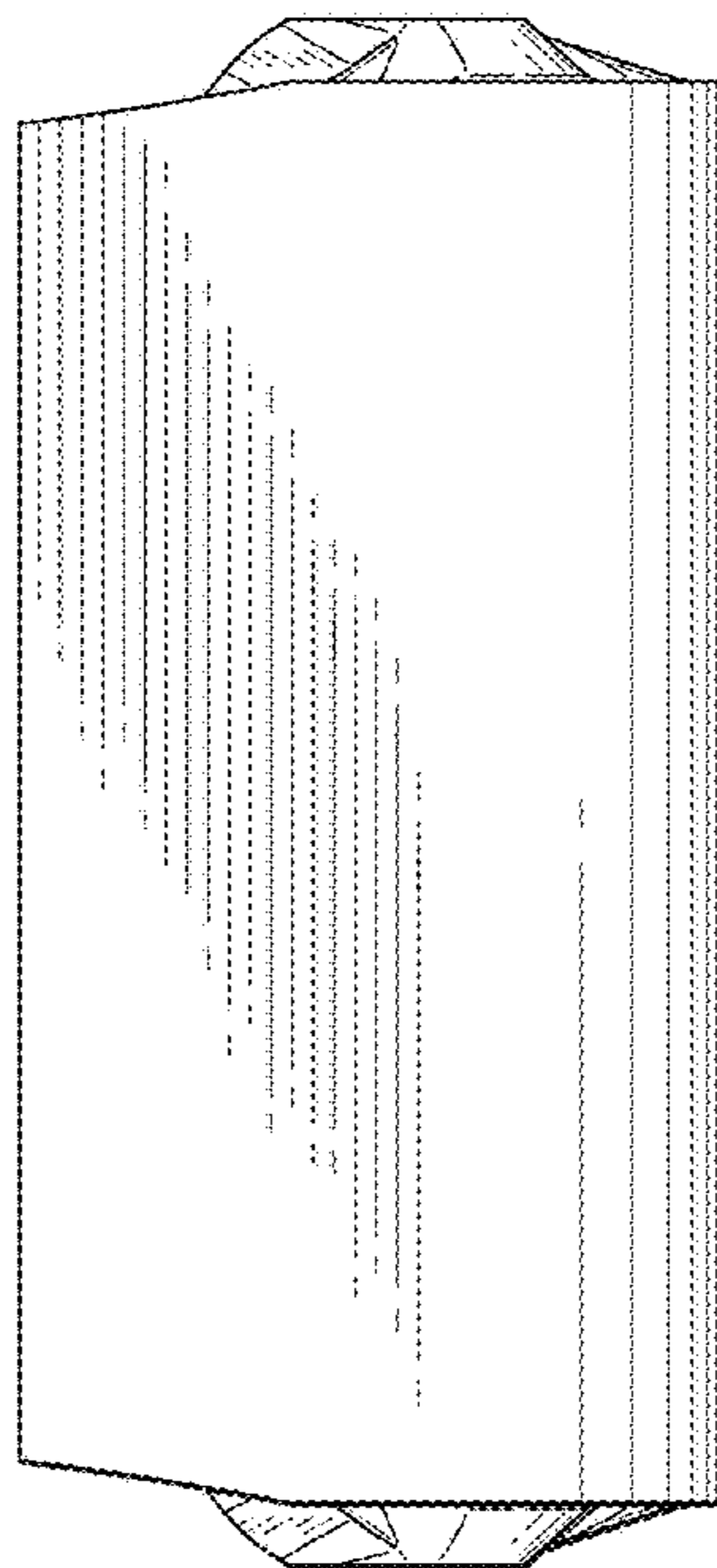

FIG.33

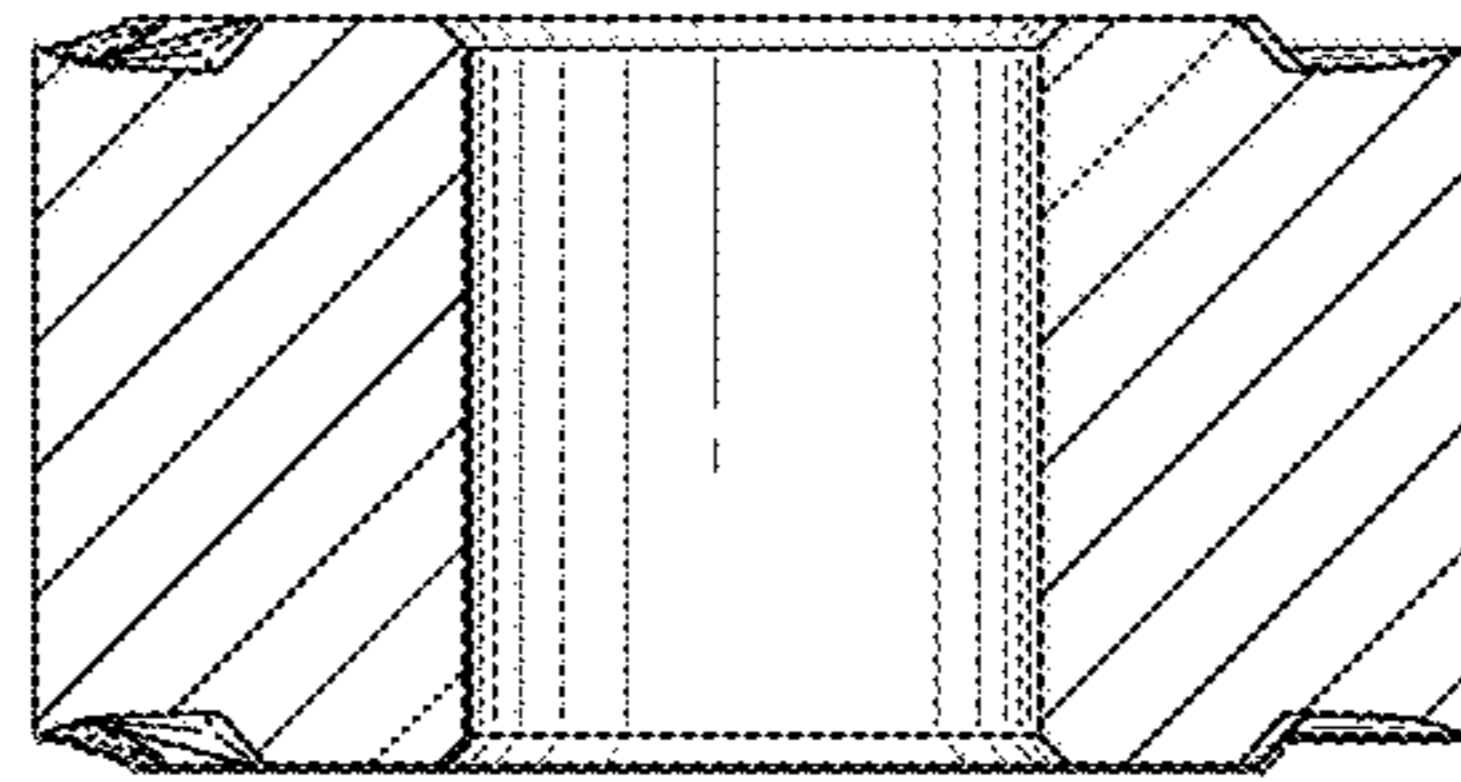

FIG.34

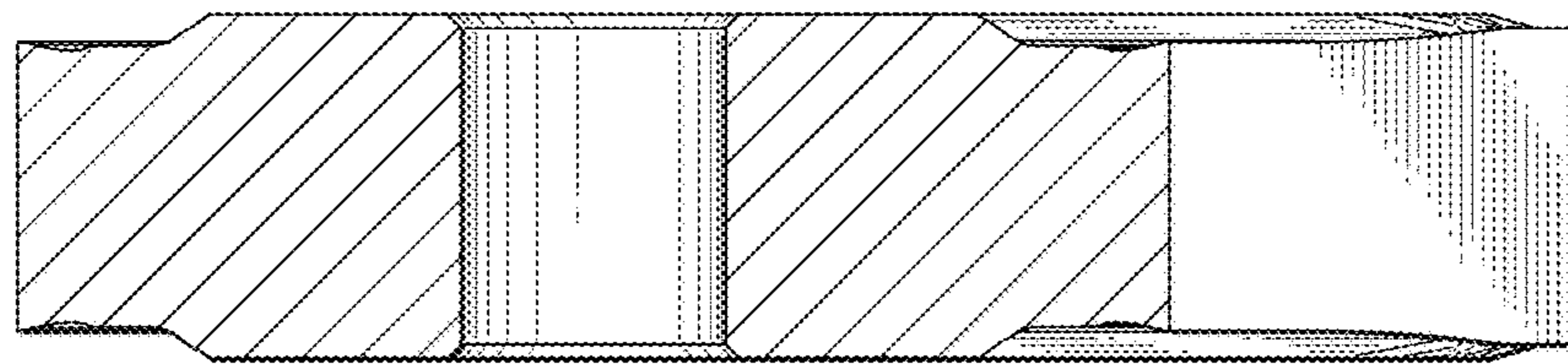

FIG.35

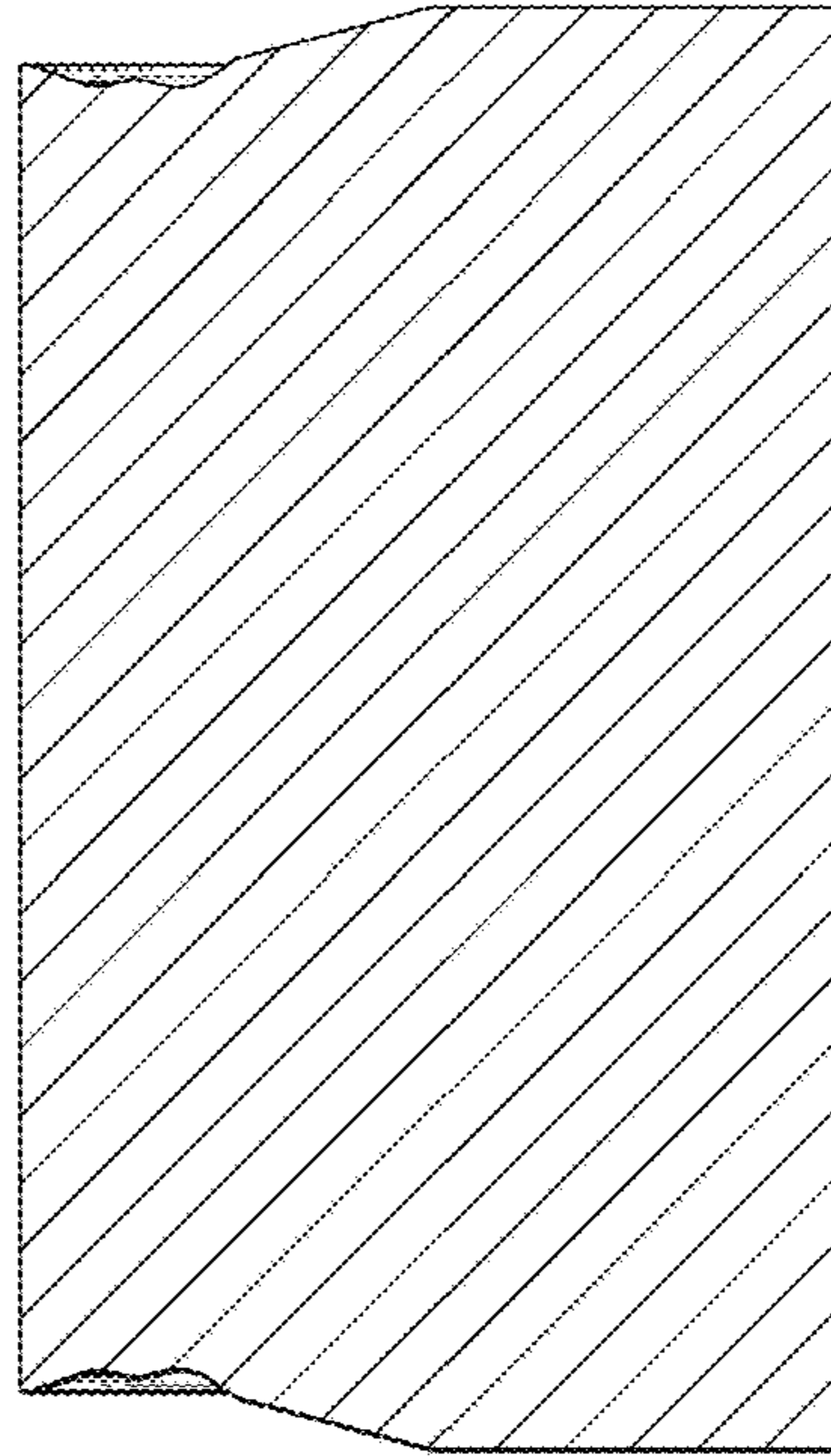

FIG.36

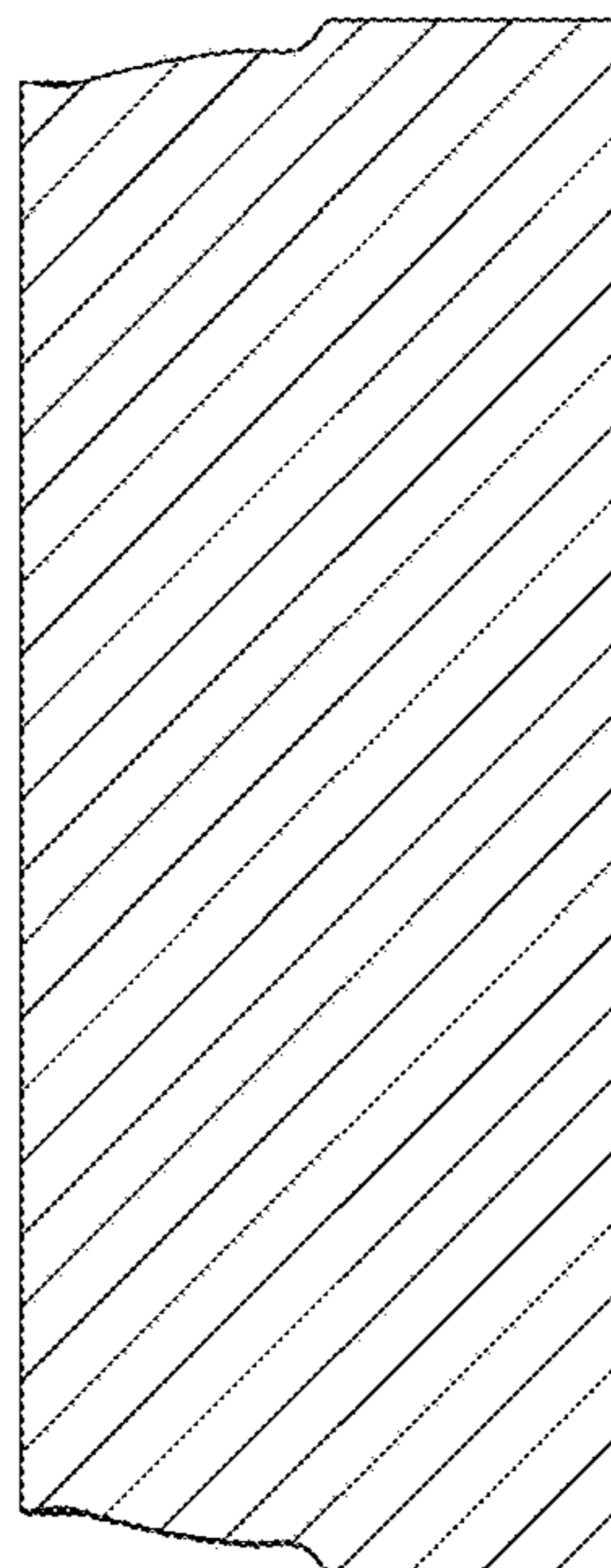



FIG.37

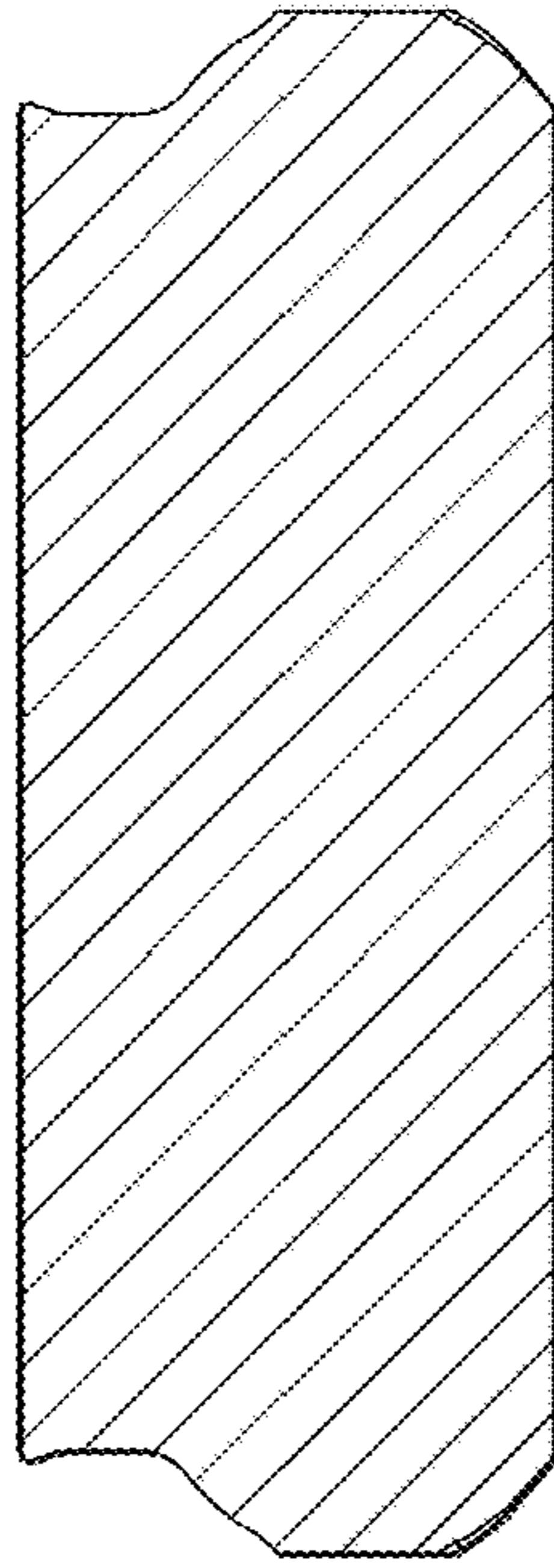

FIG.38

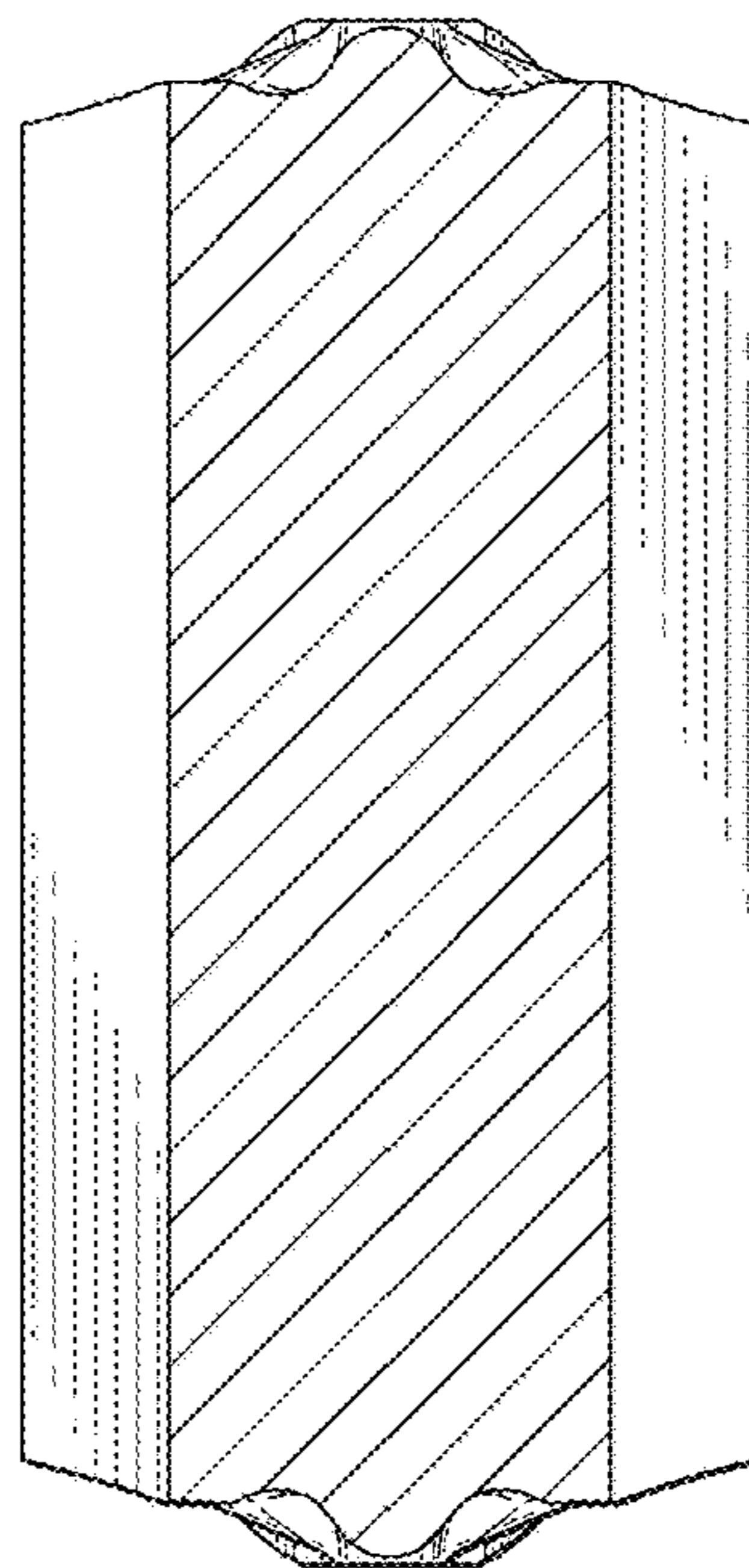

FIG.39

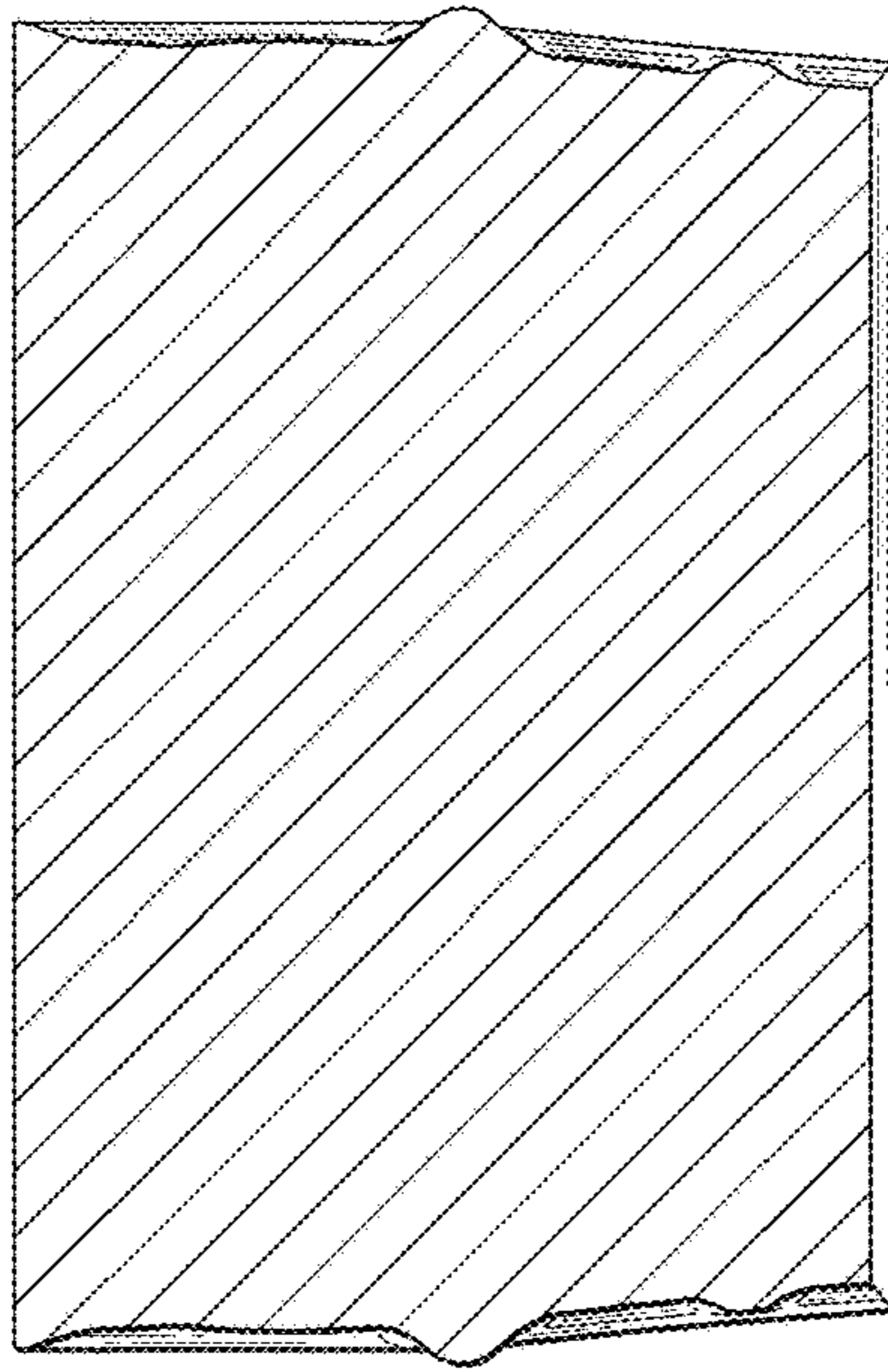

FIG.40

