



US00D871968S

(12) **United States Design Patent** (10) **Patent No.:** **US D871,968 S**
Héroux et al. (45) **Date of Patent:** **** Jan. 7, 2020**

- (54) **BUS**
- (71) Applicant: **Volvo Group Canada Inc.,**
Sainte-Claire (CA)
- (72) Inventors: **Christian Héroux,** Saint-Constant
(CA); **François Trépanier,** Québec
(CA); **Luc Bourgeois,** Laval (CA)
- (73) Assignee: **Volvo Group Canada Inc.,**
Sainte-Claire Quebec (CA)
- (**) Term: **15 Years**
- (21) Appl. No.: **29/654,767**
- (22) Filed: **Jun. 27, 2018**
- (51) **LOC (12) Cl.** **12-08**
- (52) **U.S. Cl.**
USPC **D12/84**
- (58) **Field of Classification Search**
USPC D12/84, 82, 86, 92, 100
CPC B62D 31/02; B62D 31/04; B62D 33/0612;
B62D 47/02; B62D 2021/0067
See application file for complete search history.

(56) **References Cited**

U.S. PATENT DOCUMENTS

D301,996 S *	7/1989	Manning	D12/84
D305,623 S *	1/1990	Gallitzendoerfer	D12/84
D345,120 S *	3/1994	Normand, Jr.	D12/84
D376,562 S *	12/1996	Sealy	D12/84
D442,888 S *	5/2001	Papke	D12/84
D503,126 S *	3/2005	Papke	D12/84
D617,236 S *	6/2010	Counts	D12/84
D628,937 S *	12/2010	Lian	D12/84
D704,595 S *	5/2014	Streicher	D12/84
D718,659 S *	12/2014	Lin	D12/84
D721,297 S *	1/2015	Zhang	D12/84
D721,298 S *	1/2015	Li	D12/84

D774,943 S *	12/2016	Kovos	D12/84
D776,839 S *	1/2017	Trépanier et al.	
D780,630 S *	3/2017	Frykholm	D12/84
D786,736 S *	5/2017	Besson	D12/84
D789,249 S *	6/2017	Iparraguirre	D12/84
D811,937 S *	3/2018	Lenz	D12/84

(Continued)

OTHER PUBLICATIONS

Renderings of Prevost commercialize vehicle, H-Series H3-45 VIP and Coach, Disclosed at UMA Expo, Tampa, FL, 2011, 2 Pages.

(Continued)

Primary Examiner — Michelle E. Wilson

Assistant Examiner — Clese Moore, Jr.

(74) *Attorney, Agent, or Firm* — Tucker Ellis LLP

(57) **CLAIM**

The ornamental design for a bus, as shown and described.

DESCRIPTION

FIG. 1 is a front-right perspective view of a bus showing our new design;
 FIG. 2 is rear-left perspective view thereof;
 FIG. 3 is a front view thereof, shown in enlarged scale;
 FIG. 4 is a rear view thereof;
 FIG. 5 is a left side view thereof, shown in reduced scale relative to the front and rear views;
 FIG. 6 is a right side view thereof;
 FIG. 7 is a top view thereof;
 FIG. 8 is a front-right perspective view of a second embodiment of the bus;
 FIG. 9 is rear-left perspective view thereof;
 FIG. 10 is a front view thereof, shown in enlarged scale;
 FIG. 11 is a rear view thereof;
 FIG. 12 is a left side view thereof, shown in reduced scale relative to the front and rear views;
 FIG. 13 is a right side view thereof; and,
 FIG. 14 is a top view thereof.

1 Claim, 14 Drawing Sheets



(56)

References Cited

U.S. PATENT DOCUMENTS

D811,938 S * 3/2018 Lenz D12/84
D816,549 S * 5/2018 Iparraguirre D12/84

OTHER PUBLICATIONS

Renderings of Prevost commercialize vehicle, X-Series X3-45 VIP Entertainer, VIP Motorhome, Commuter and Coach, Disclosed at UMA Expo, Atlanta, GA 2016, 4 Pages.

Volvo D13 SCR: Image of MTA New York City Bus 2014 Prevost x3-45 2490, posted to Flickr by Shane Ramkissoon on Apr. 11, 2014, 1 page.

* cited by examiner

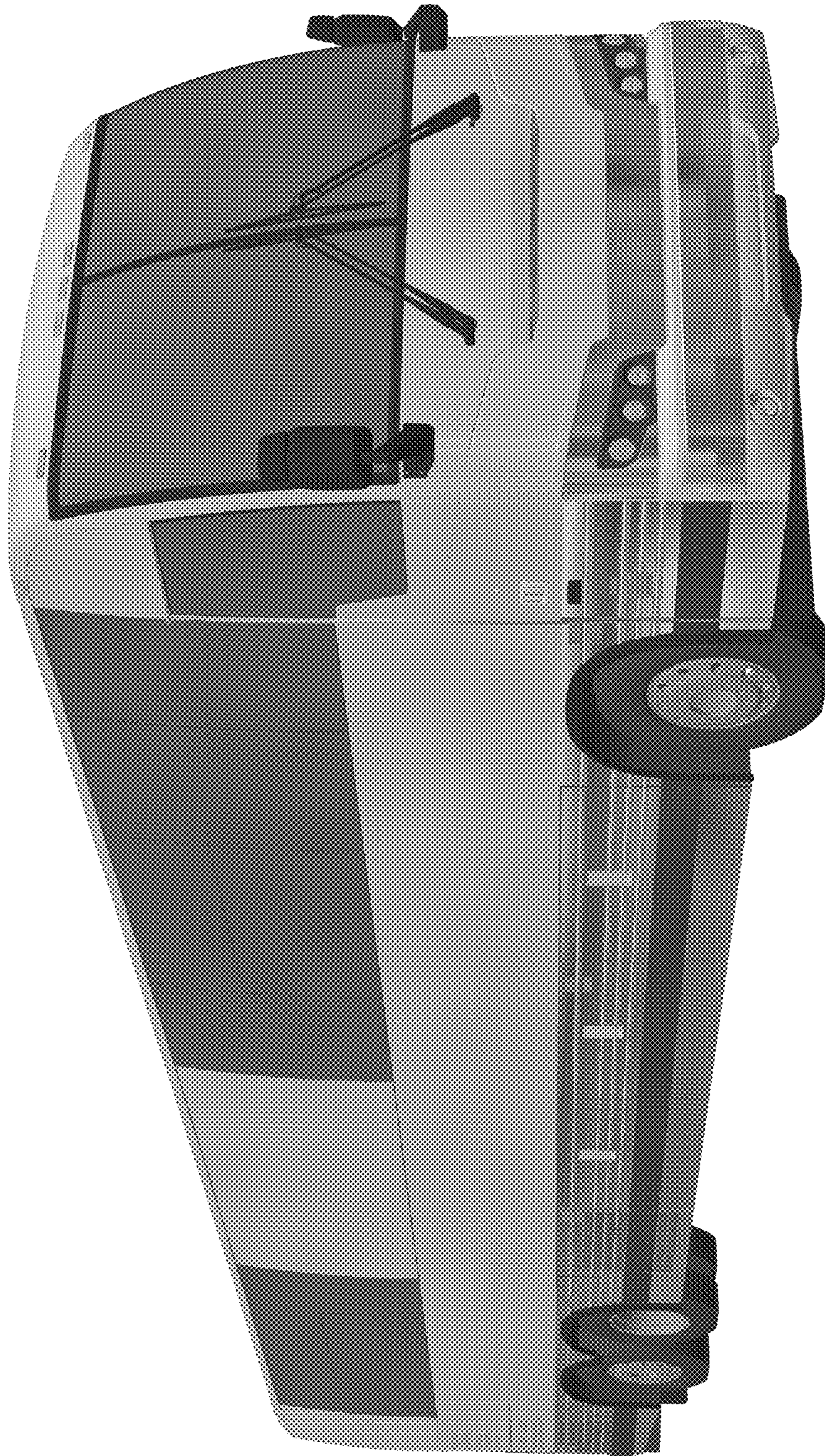

FIG. 1

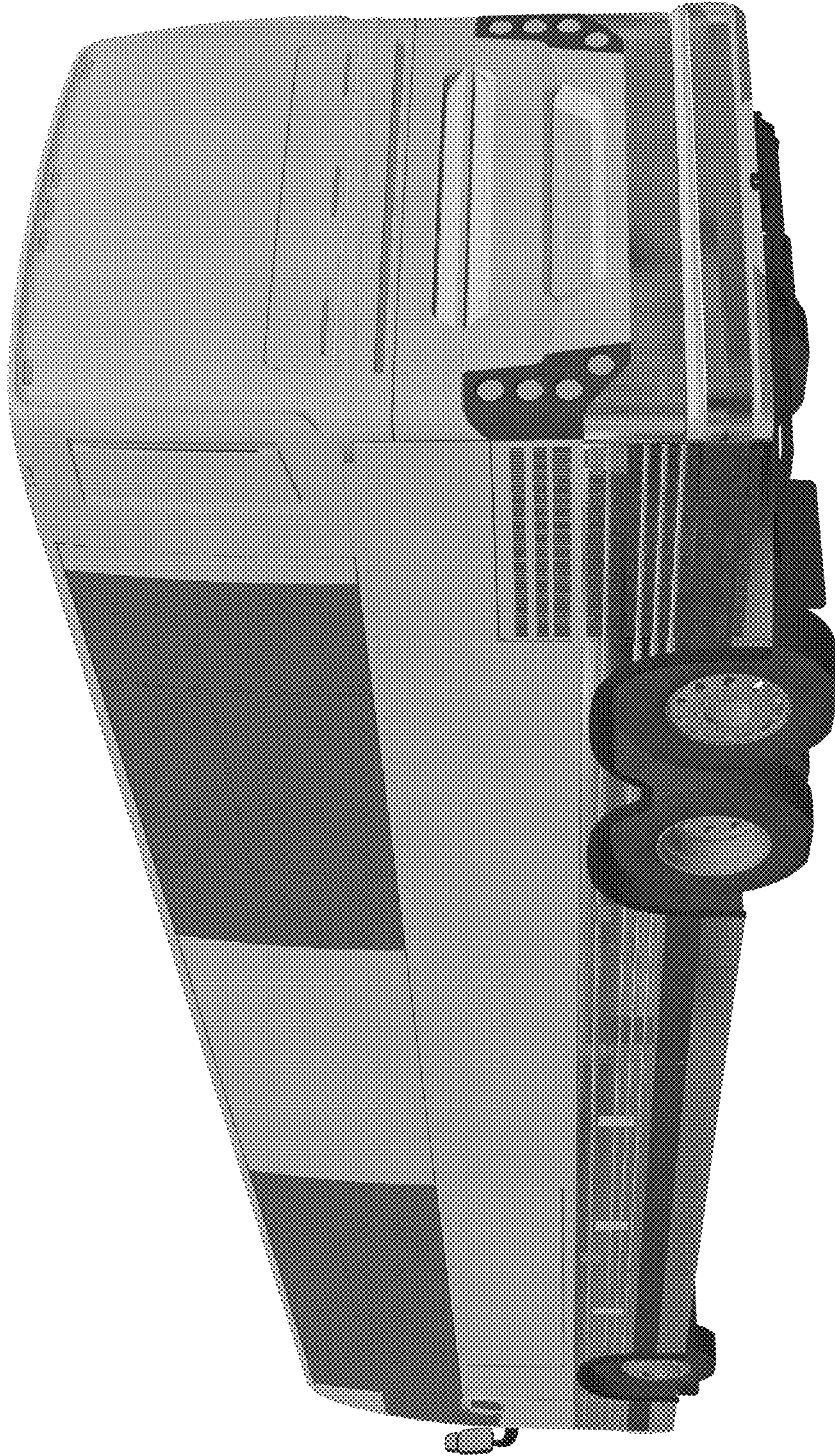

FIG. 2

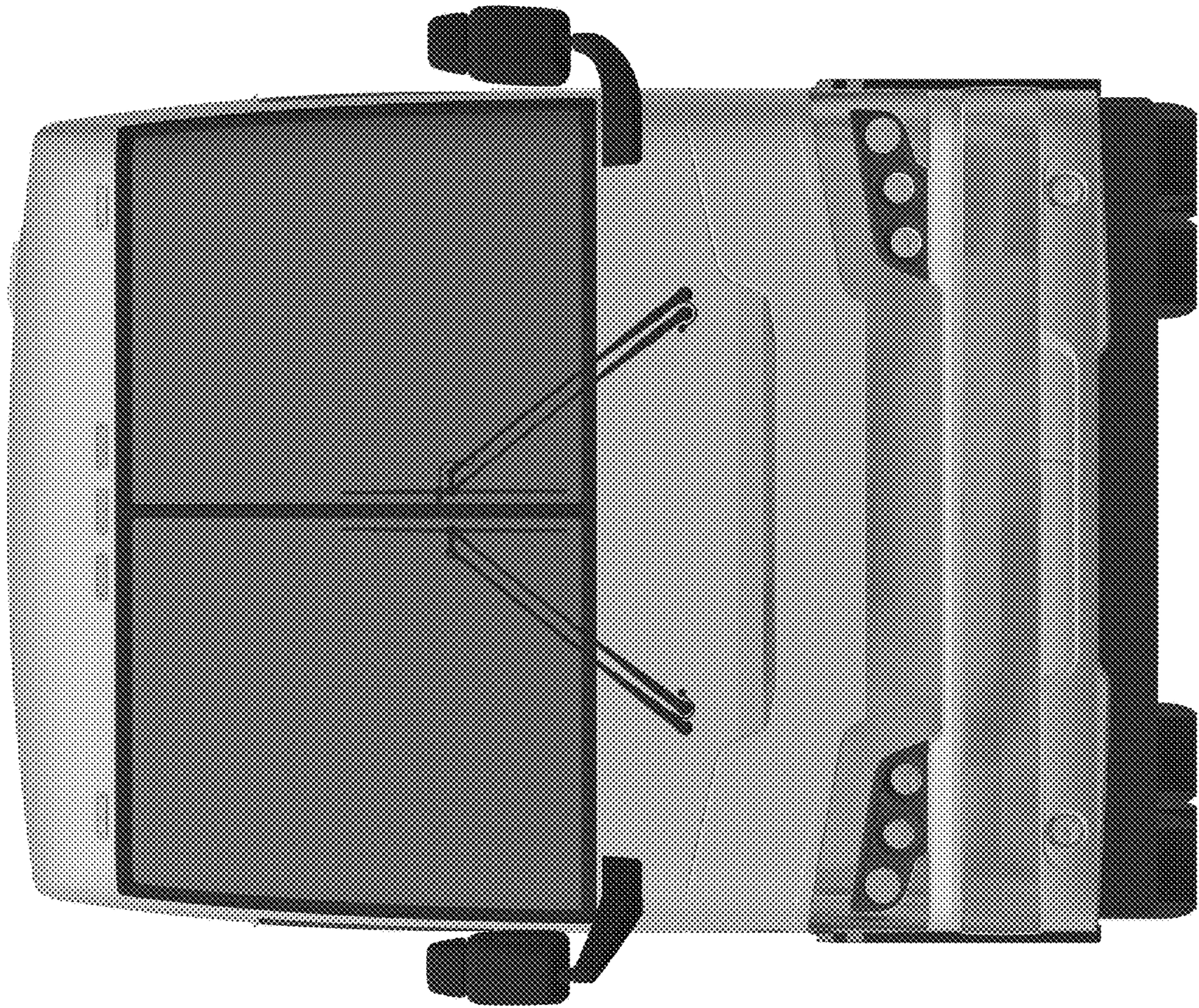

FIG. 3

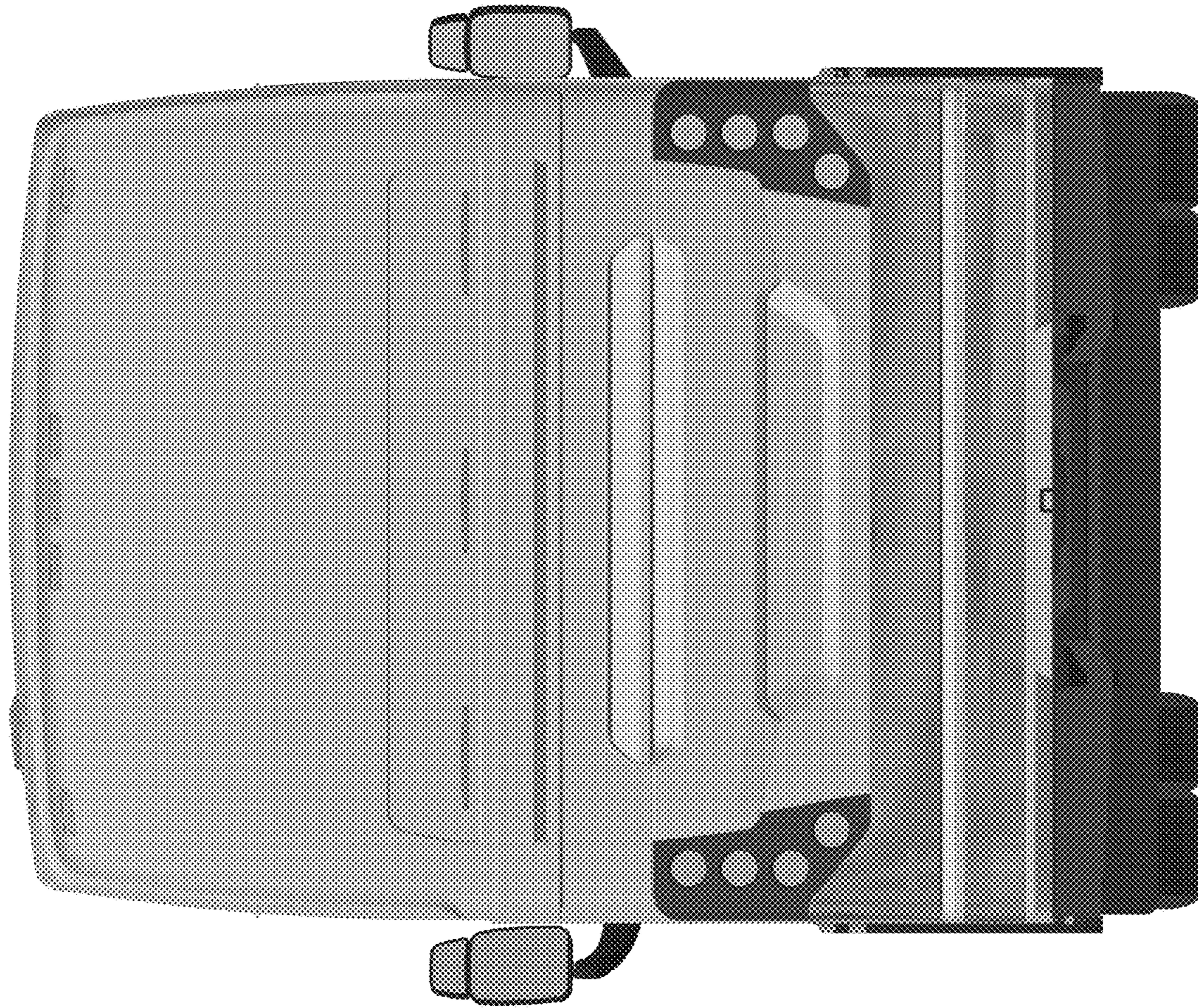

FIG. 4

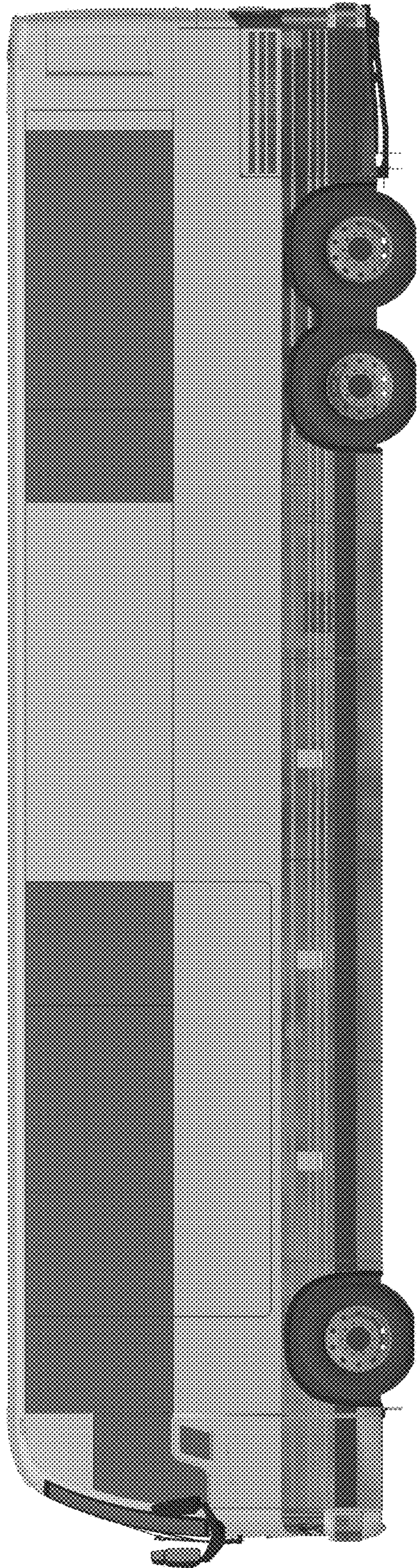

FIG. 5

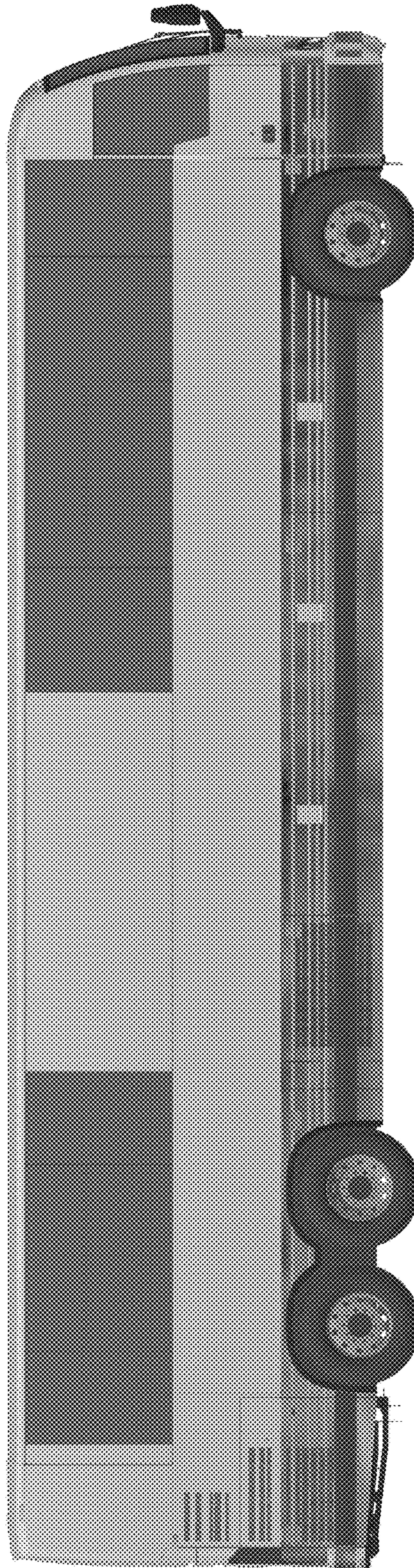

FIG. 6

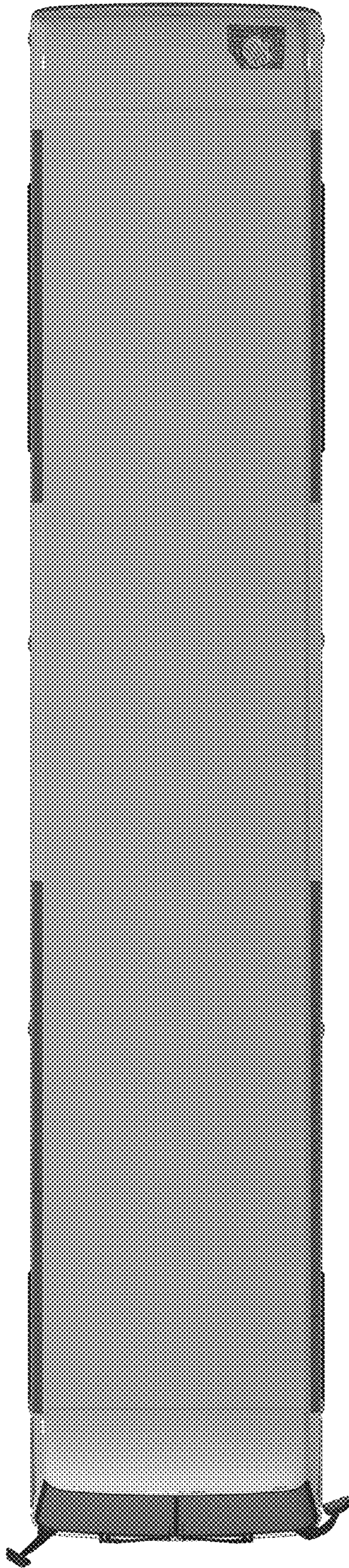

FIG. 7

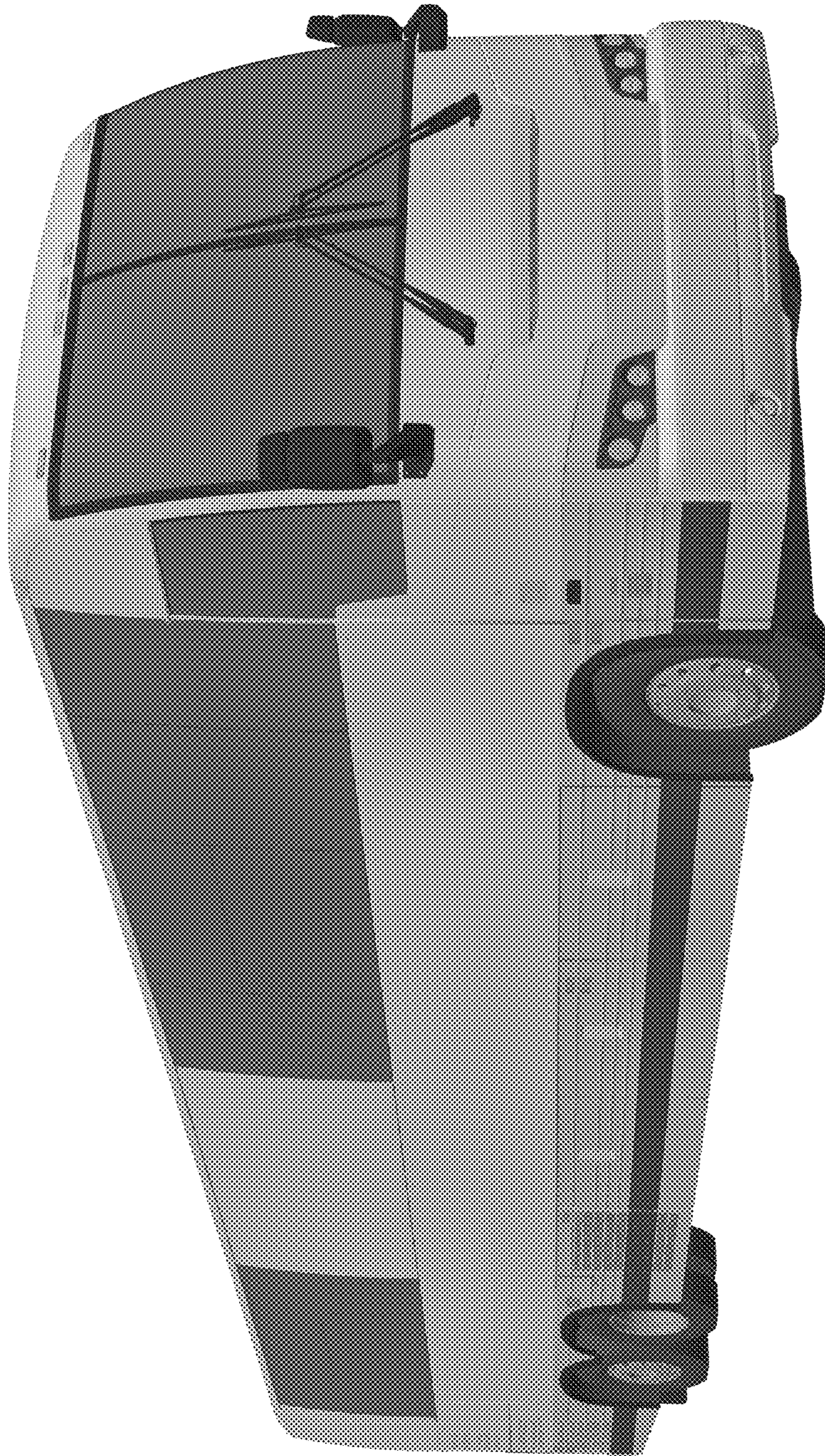

FIG. 8

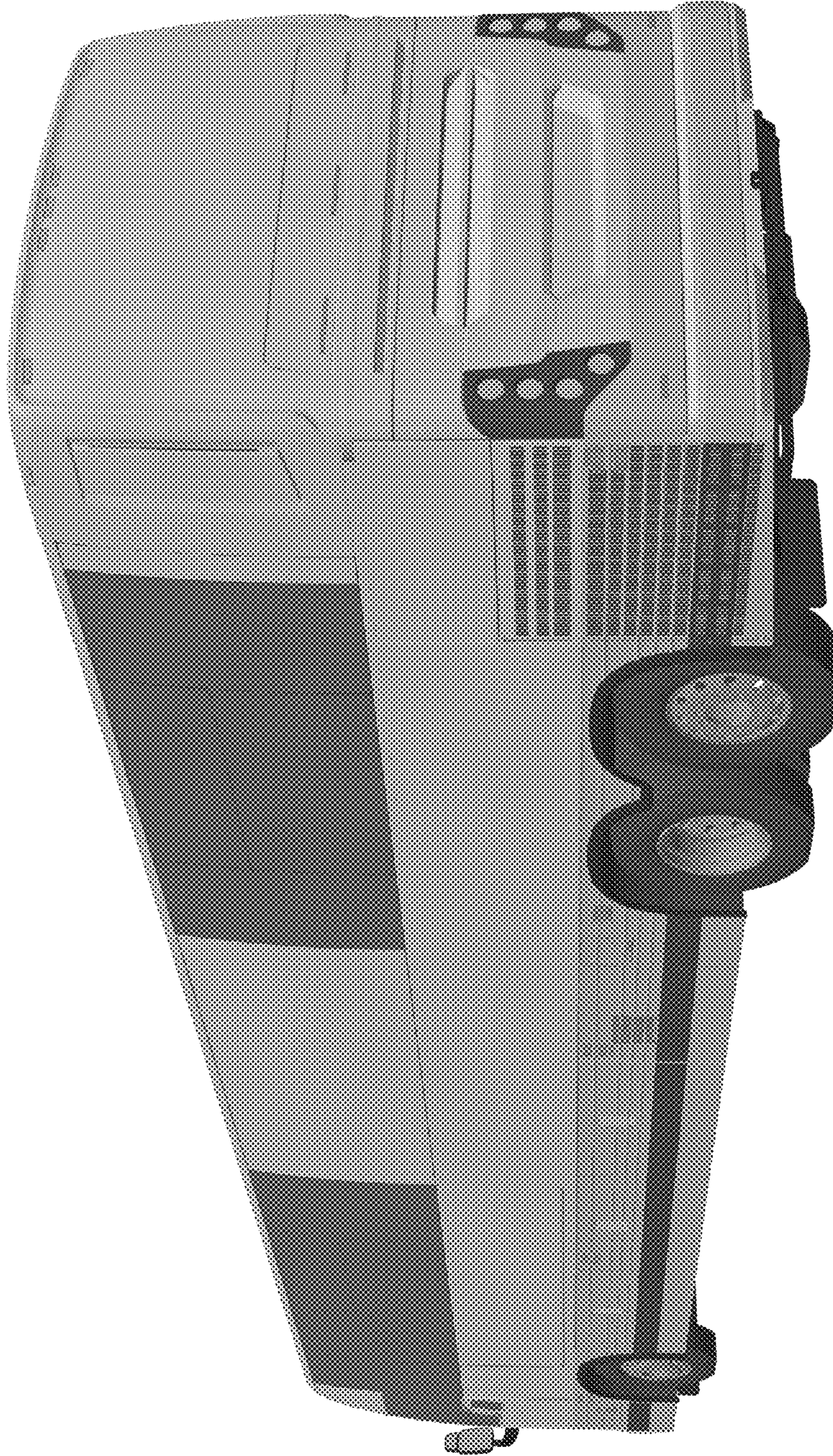

FIG. 9

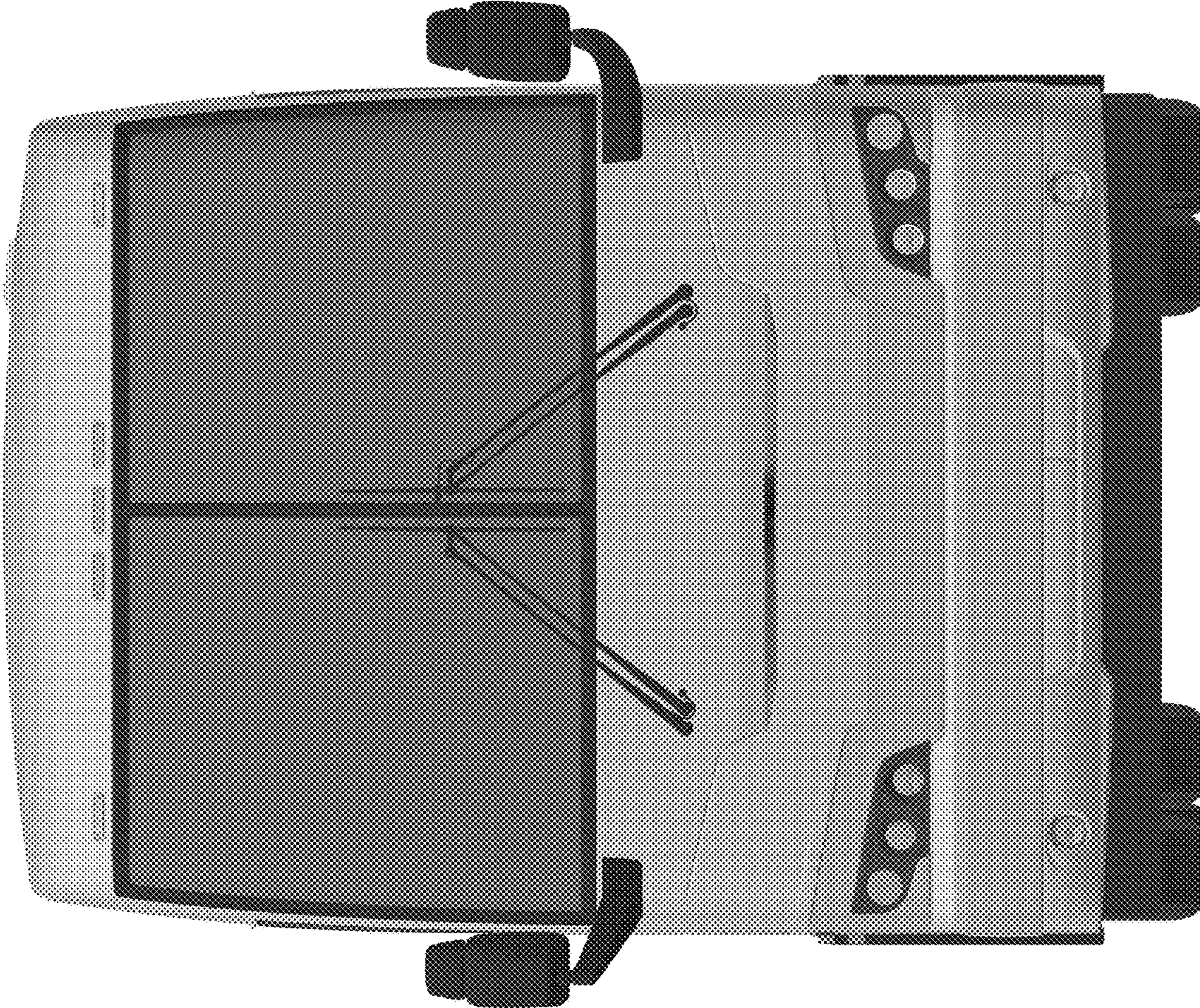

FIG. 10

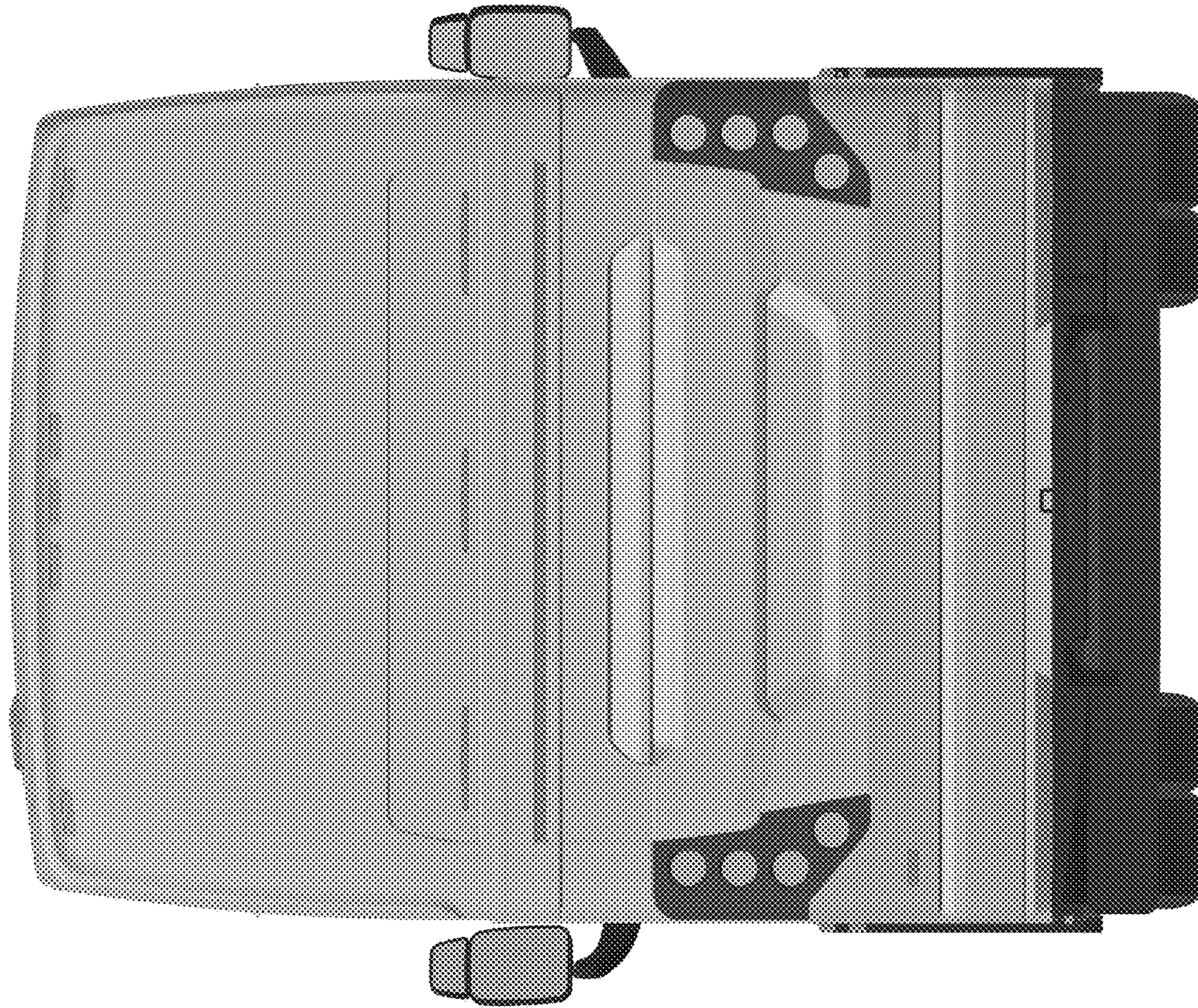

FIG. 11

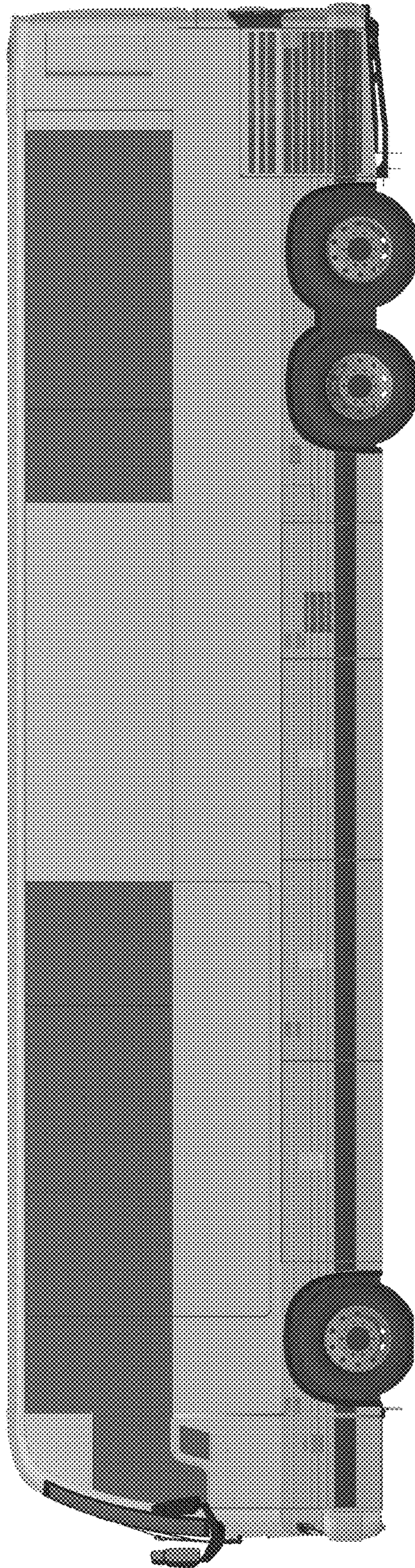

FIG. 12

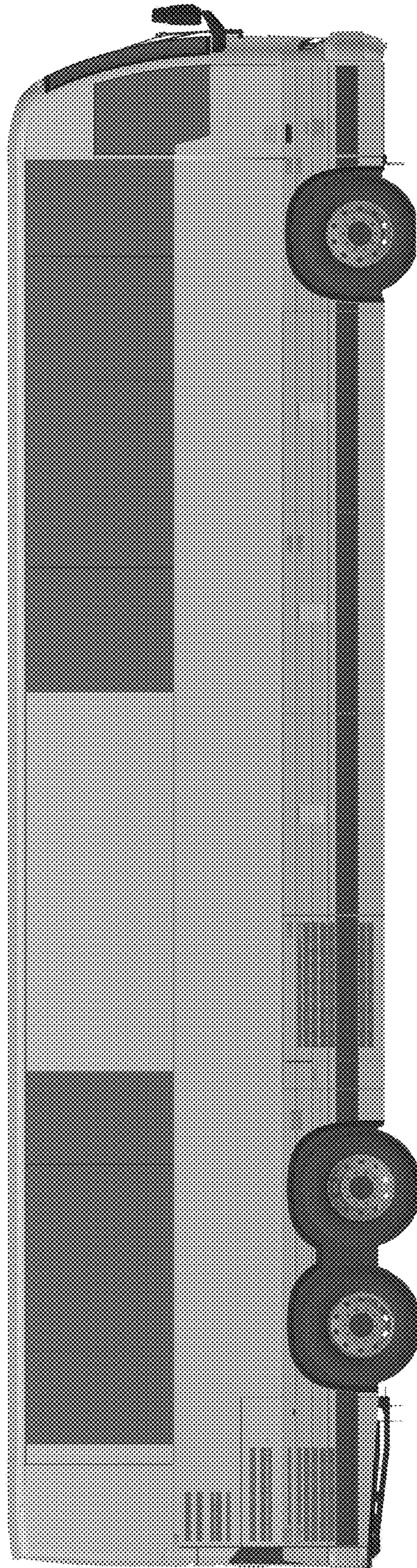

FIG. 13

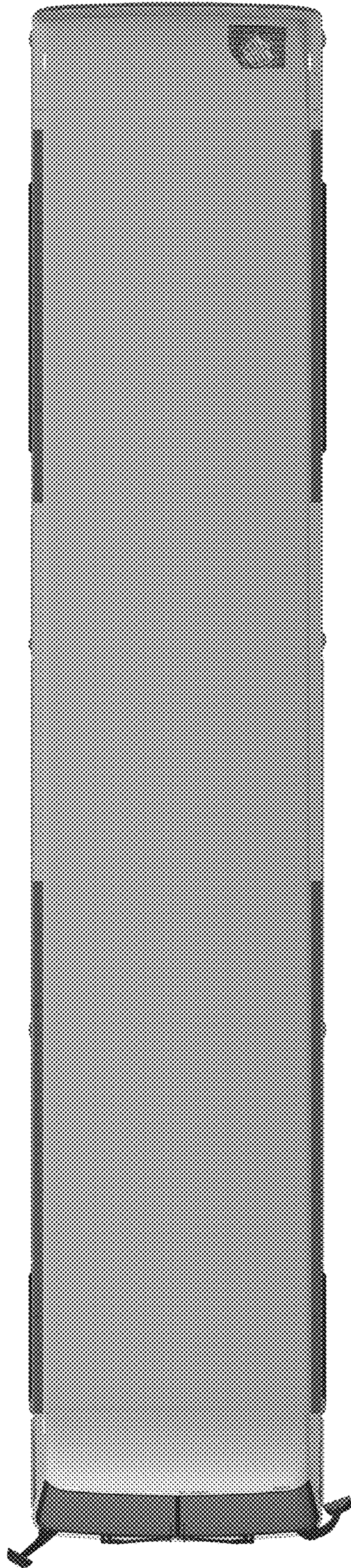

FIG. 14