



US00D871942S

(12) **United States Design Patent**  
**Epps**

(10) **Patent No.:** **US D871,942 S**  
(45) **Date of Patent:** **\*\* Jan. 7, 2020**

(54) **TAPE MEASURE DEPLOYMENT AID**

(71) Applicant: **Joshua Keicher Epps**, Vienna, GA  
(US)

(72) Inventor: **Joshua Keicher Epps**, Vienna, GA  
(US)

(\*\*) Term: **15 Years**

(21) Appl. No.: **29/668,310**

(22) Filed: **Oct. 29, 2018**

(51) **LOC (12) Cl.** ..... **10-04**

(52) **U.S. Cl.**  
USPC ..... **D10/74**

(58) **Field of Classification Search**  
USPC ..... D10/74  
CPC ..... G01B 3/1056; G01B 2003/1074; G01B  
2003/1076; G01B 2003/1079; G01B  
2003/1048; G01B 3/1096; G01B 3/1041  
See application file for complete search history.

(56) **References Cited**

**U.S. PATENT DOCUMENTS**

D438,130 S \* 2/2001 Modisett ..... D10/74

\* cited by examiner

*Primary Examiner* — Antoine Duval Davis

(74) *Attorney, Agent, or Firm* — Michael J. Bootcheck,  
LLC; Michael J. Bootcheck

(57) **CLAIM**

The ornamental design for a tape measure deployment aid,  
as shown and described.

**DESCRIPTION**

FIG. 1 is a perspective view of the tape measure deployment aid;  
FIG. 2 is a side view thereof;  
FIG. 3 is an opposite side view thereof;  
FIG. 4 is a bottom view thereof;  
FIG. 5 is a top view thereof;  
FIG. 6 is a front view thereof; and,  
FIG. 7 is a rear view thereof.

**1 Claim, 3 Drawing Sheets**

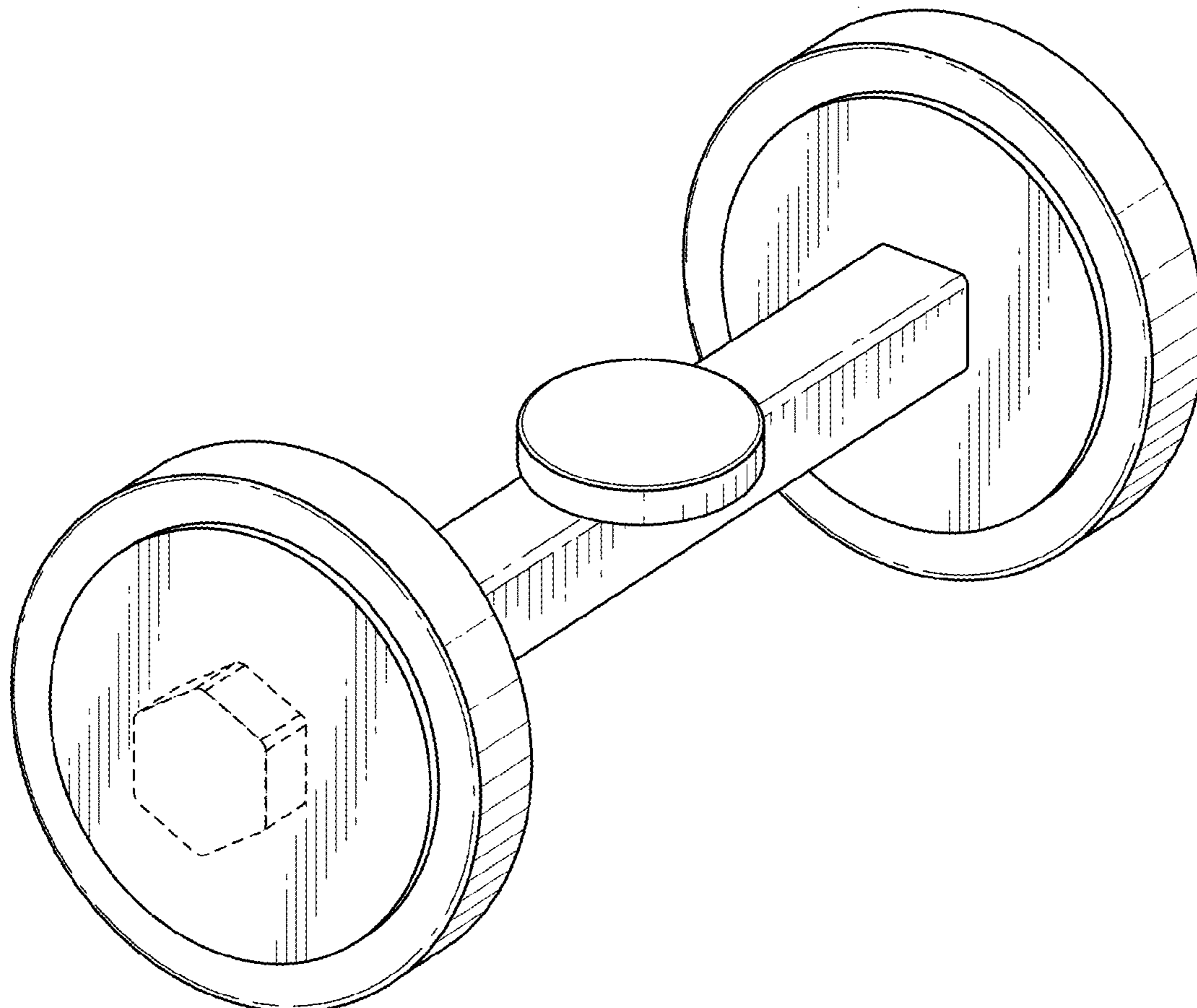

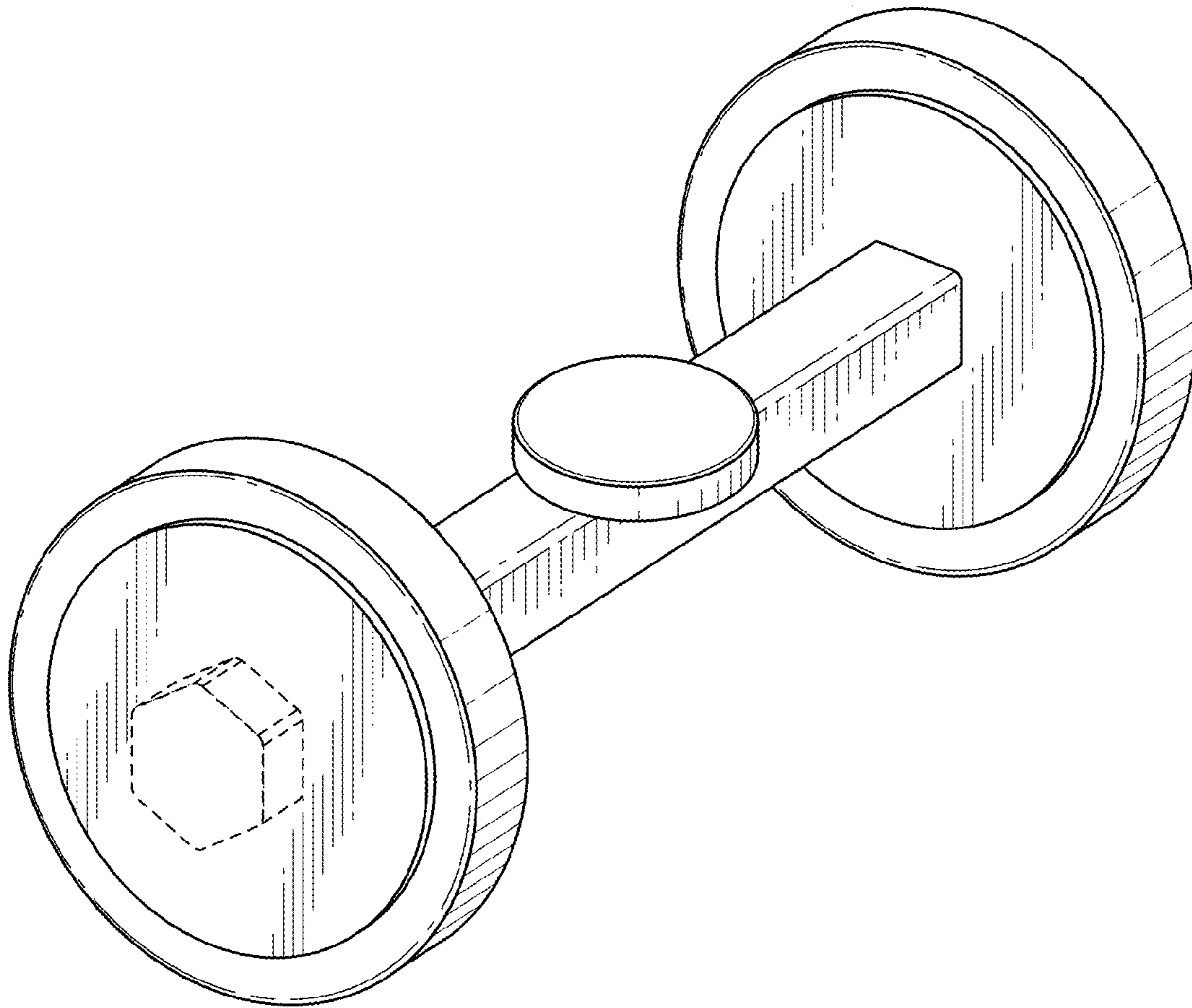

FIG. 1

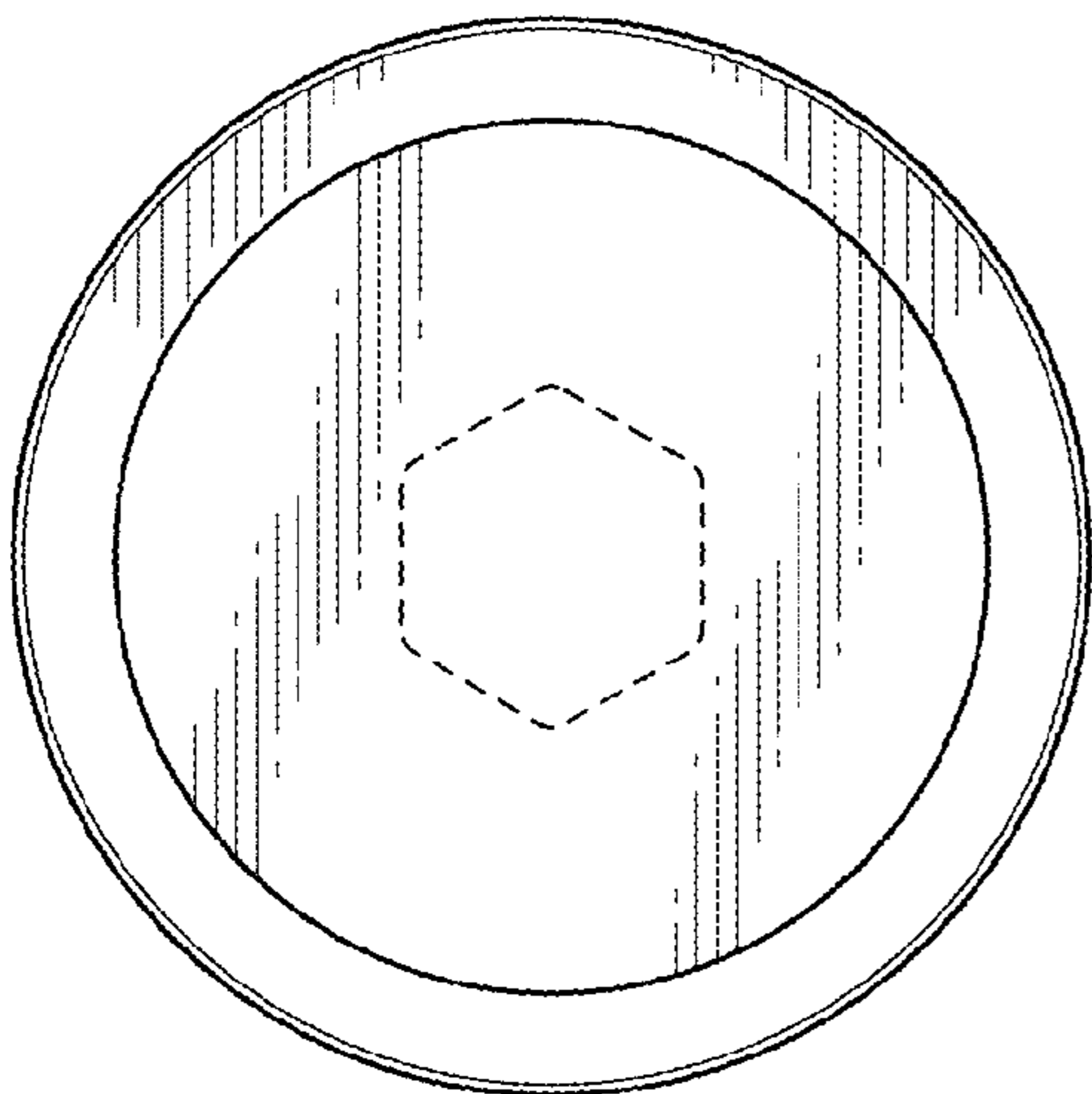

FIG. 2

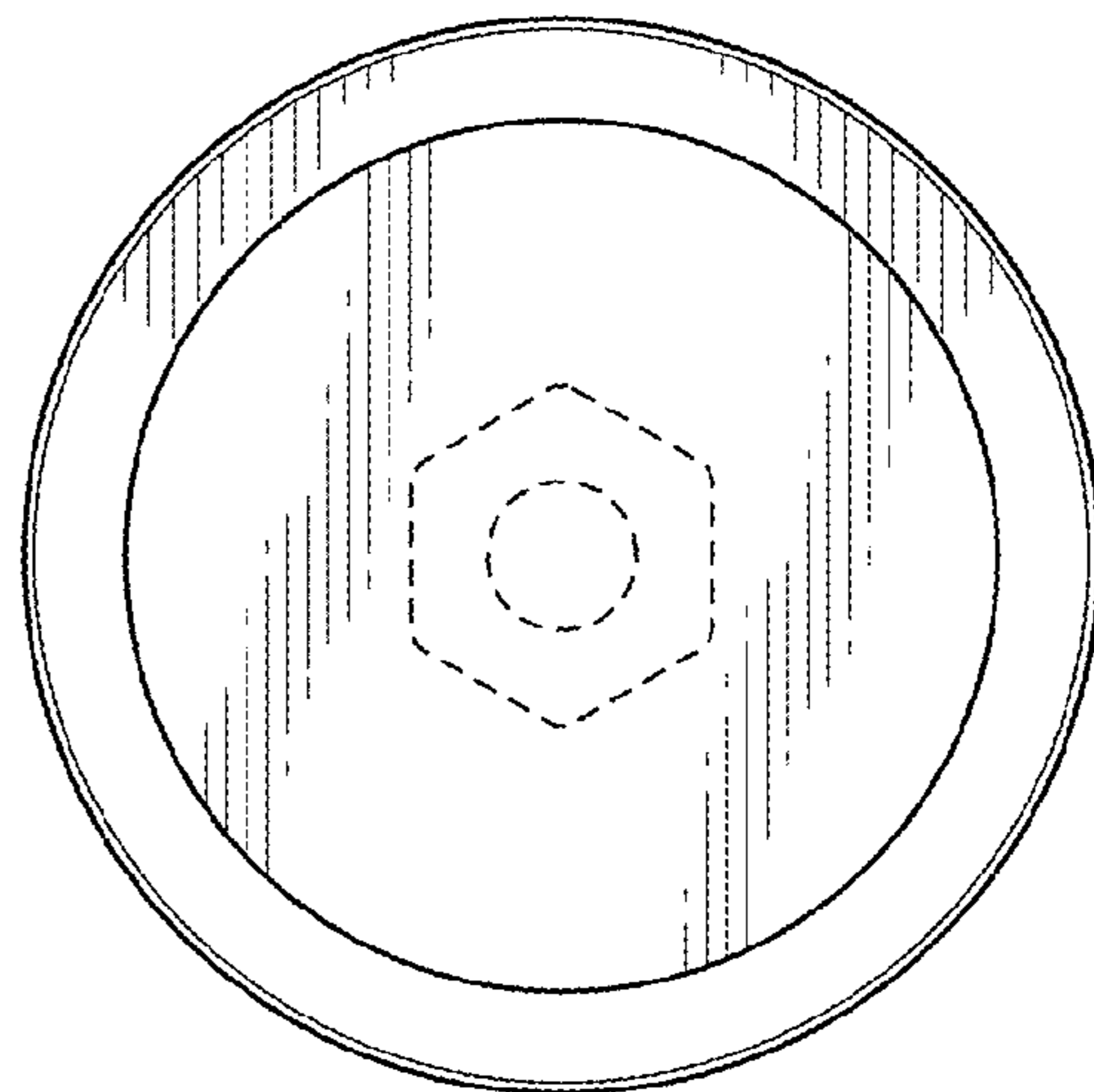

FIG. 3

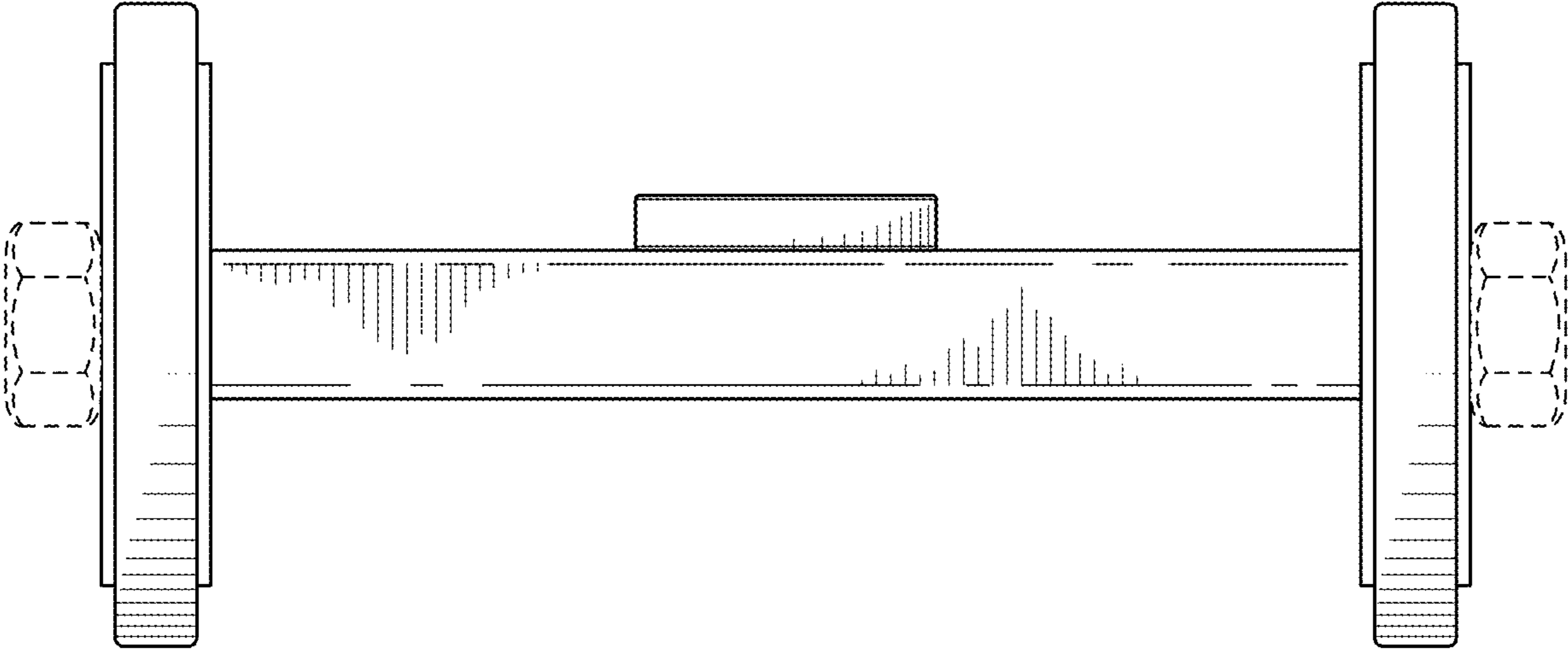

FIG. 4

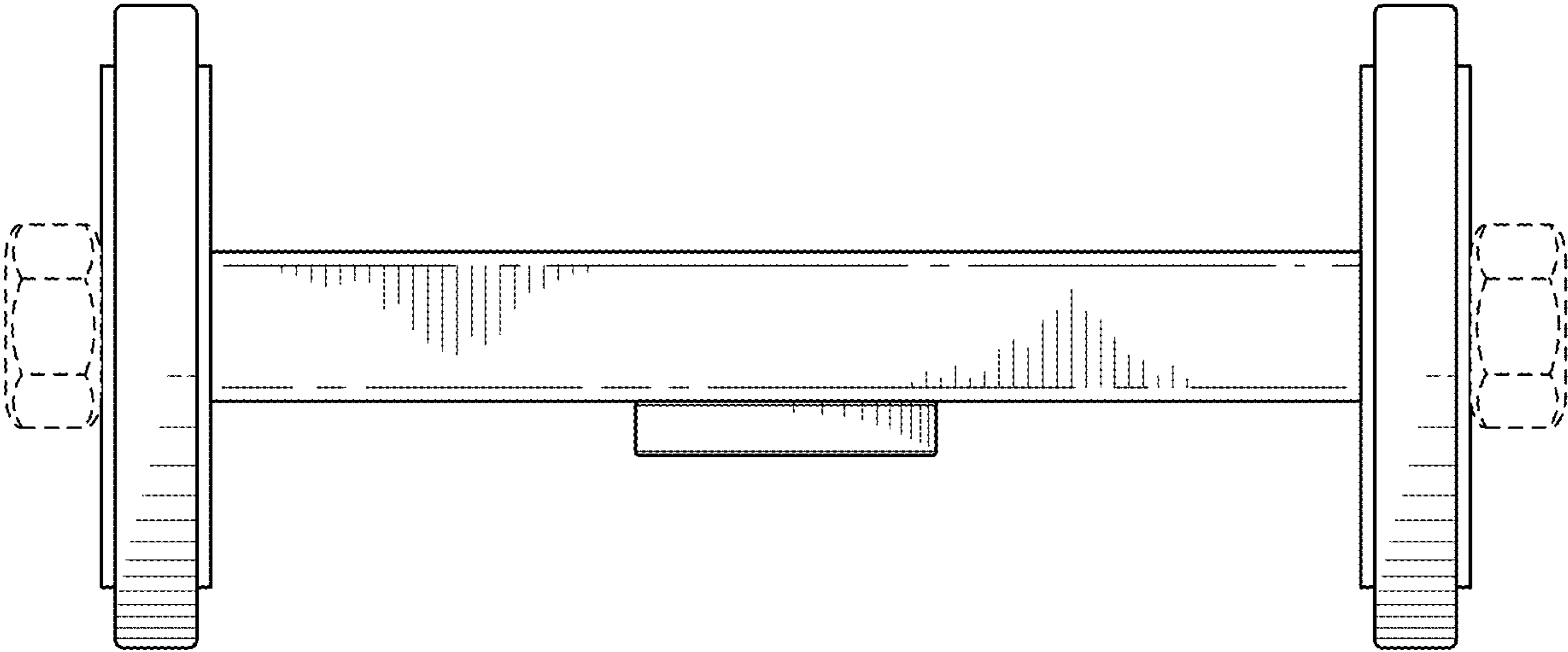

FIG. 5

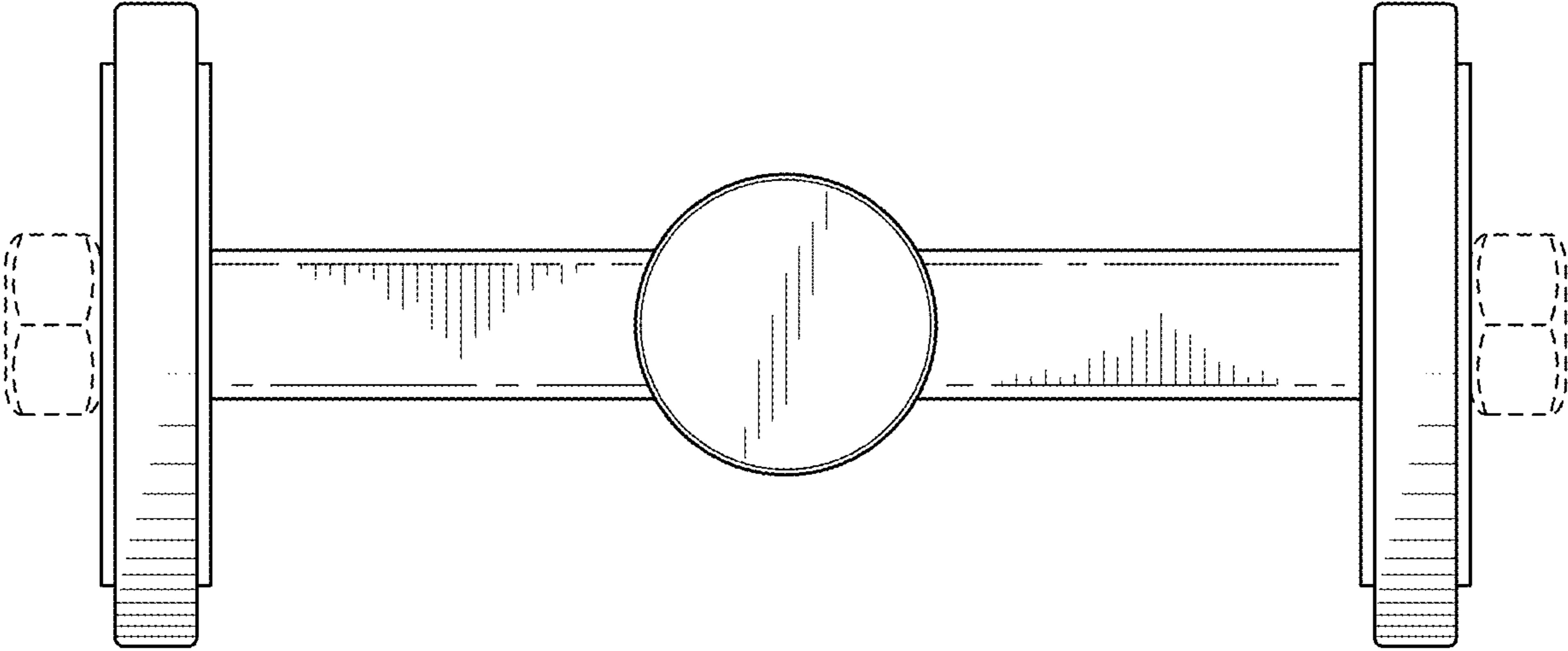

FIG. 6

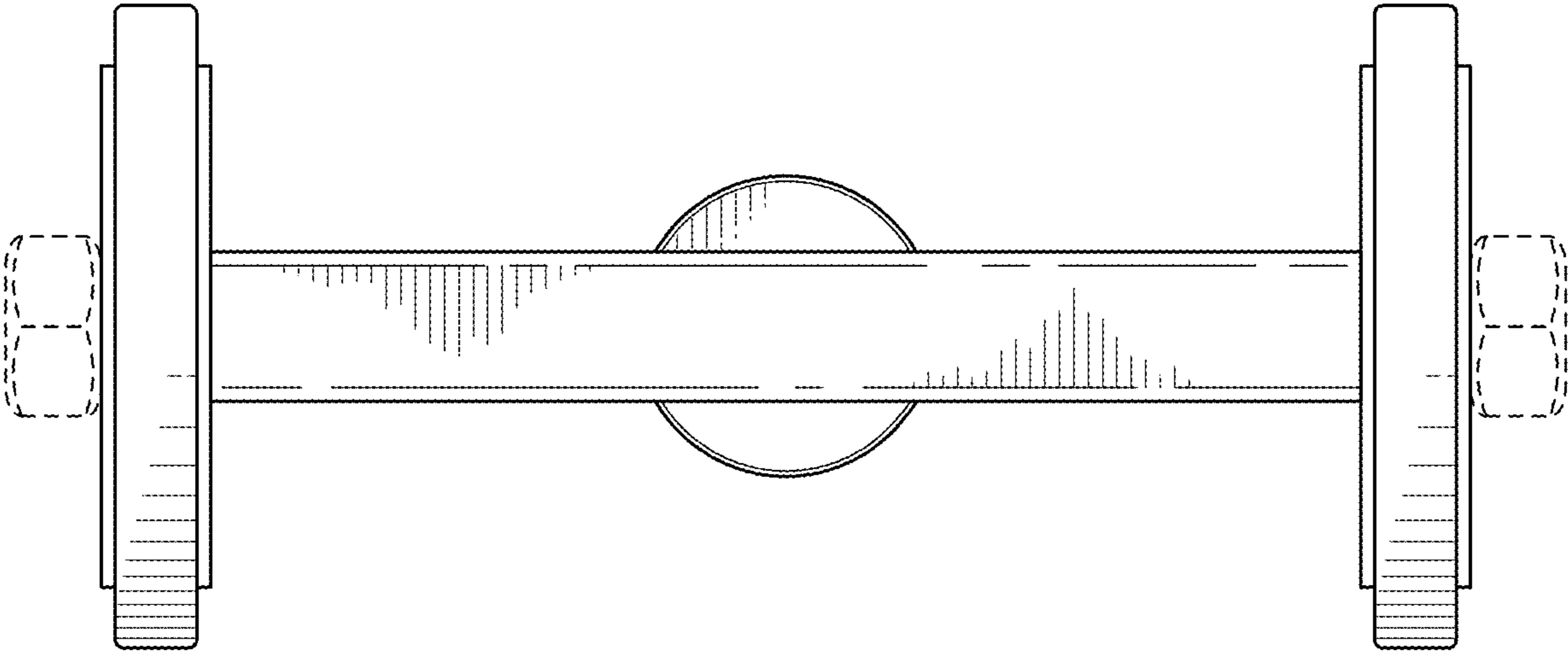

FIG. 7