



US00D871911S

(12) **United States Design Patent**
Zhou

(10) **Patent No.:** **US D871,911 S**
(45) **Date of Patent:** **** Jan. 7, 2020**

(54) **BEVERAGE BOTTLE**

(71) Applicant: **Shenzhen Ganten Food and Drink Co., Ltd, Shenzhen, Guangdong (CN)**

(72) Inventor: **Jingliang Zhou, Guangdong (CN)**

(73) Assignee: **Shenzhen Ganten Food and Drink Co., Ltd, Shenzhen (CN)**

(**) Term: **15 Years**

(21) Appl. No.: **29/636,366**

(22) Filed: **Feb. 8, 2018**

(30) **Foreign Application Priority Data**

Jan. 3, 2018 (CN) 2018 3 0001895

(51) **LOC (12) Cl.** **09-01**

(52) **U.S. Cl.**
USPC **D9/538; D9/575**

(58) **Field of Classification Search**

USPC D7/300, 500, 507, 509, 523, 590, 598,
D7/602, 619.1; D9/516, 520, 529, 530,
D9/537, 538, 539, 540, 544-546, 549,
D9/550, 552, 715, 719, 575; D3/202
CPC B65D 41/42; B65D 1/0246; B65D 1/0223;
B65D 21/022

See application file for complete search history.

(56) **References Cited**

U.S. PATENT DOCUMENTS

D503,341 S * 3/2005 Delmotte D9/538
D526,902 S * 8/2006 Cummings D9/558
D644,929 S * 9/2011 White D7/509

D666,107 S * 8/2012 Blachford D9/682
D676,755 S * 2/2013 Hein D9/519
D683,237 S * 5/2013 Crawford D9/682
D683,631 S * 6/2013 Crawford D9/682
D684,864 S * 6/2013 Crawford D9/562
D689,367 S * 9/2013 Crawford D9/529
D694,629 S * 12/2013 Crawford D9/516
D731,317 S * 6/2015 Li D9/552
D741,177 S * 10/2015 Higareda D9/516
D750,966 S * 3/2016 Zhou D9/520
D782,317 S * 3/2017 Zhou D9/520
D798,722 S * 10/2017 Zhou D9/538
D837,057 S * 1/2019 Zhou D9/538
D837,658 S * 1/2019 Cabaleiro D9/552

* cited by examiner

Primary Examiner — Shannon W Morgan
Assistant Examiner — Keith Frank

(57) **CLAIM**

The ornamental design for a beverage bottle, as shown and described.

DESCRIPTION

FIG. 1 is a front elevational view of a beverage bottle showing my new design;
FIG. 2 is a rear elevational view thereof;
FIG. 3 is a left side view thereof;
FIG. 4 is a right side view thereof;
FIG. 5 is a top plan view thereof;
FIG. 6 is a bottom plan view thereof;
FIG. 7 is a first perspective view thereof; and,
FIG. 8 is a second perspective view thereof.
The broken lines in the drawings showing of the beverage bottle illustrate the portions of the bottle that form no part of the claimed design.

1 Claim, 8 Drawing Sheets

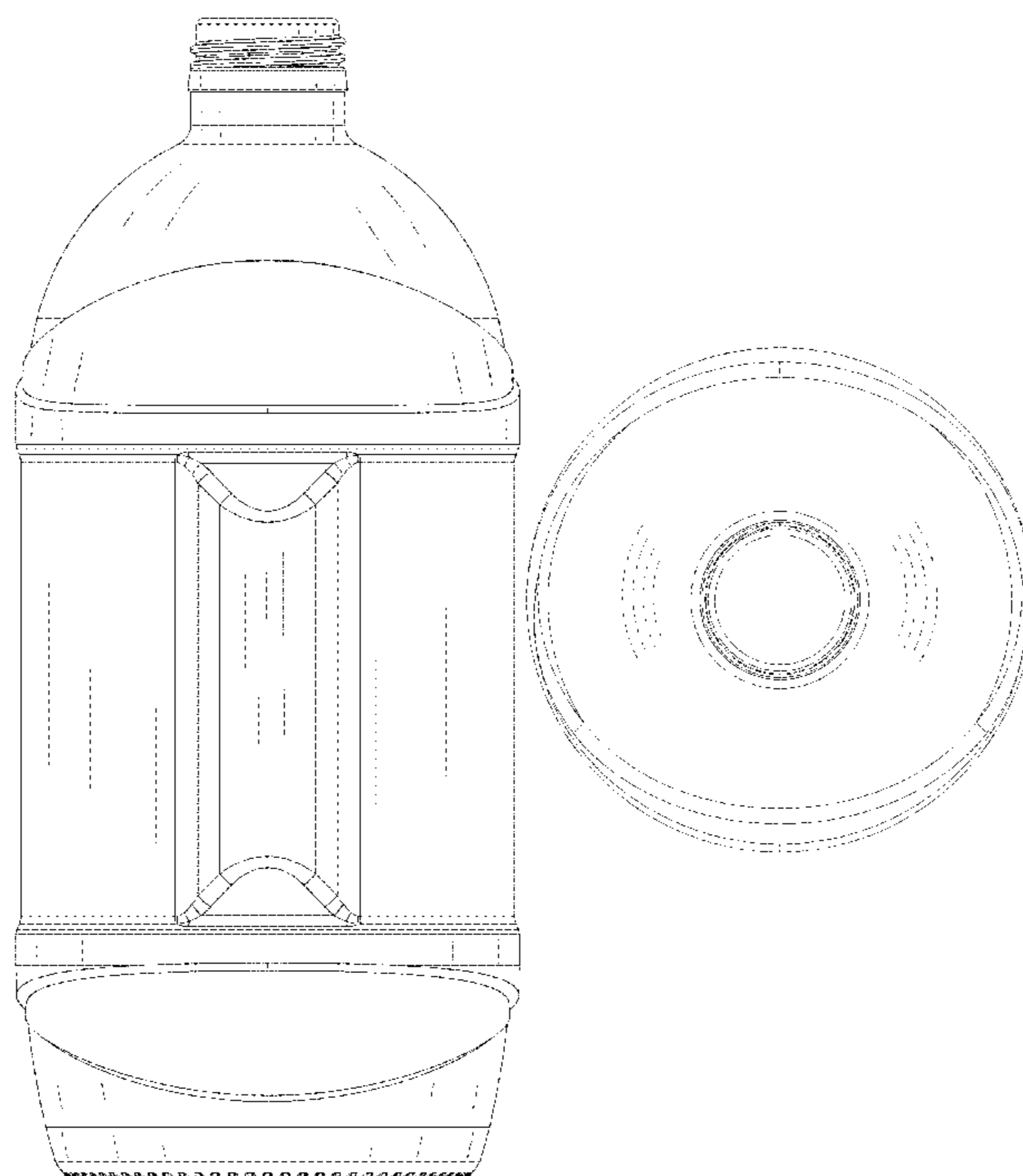

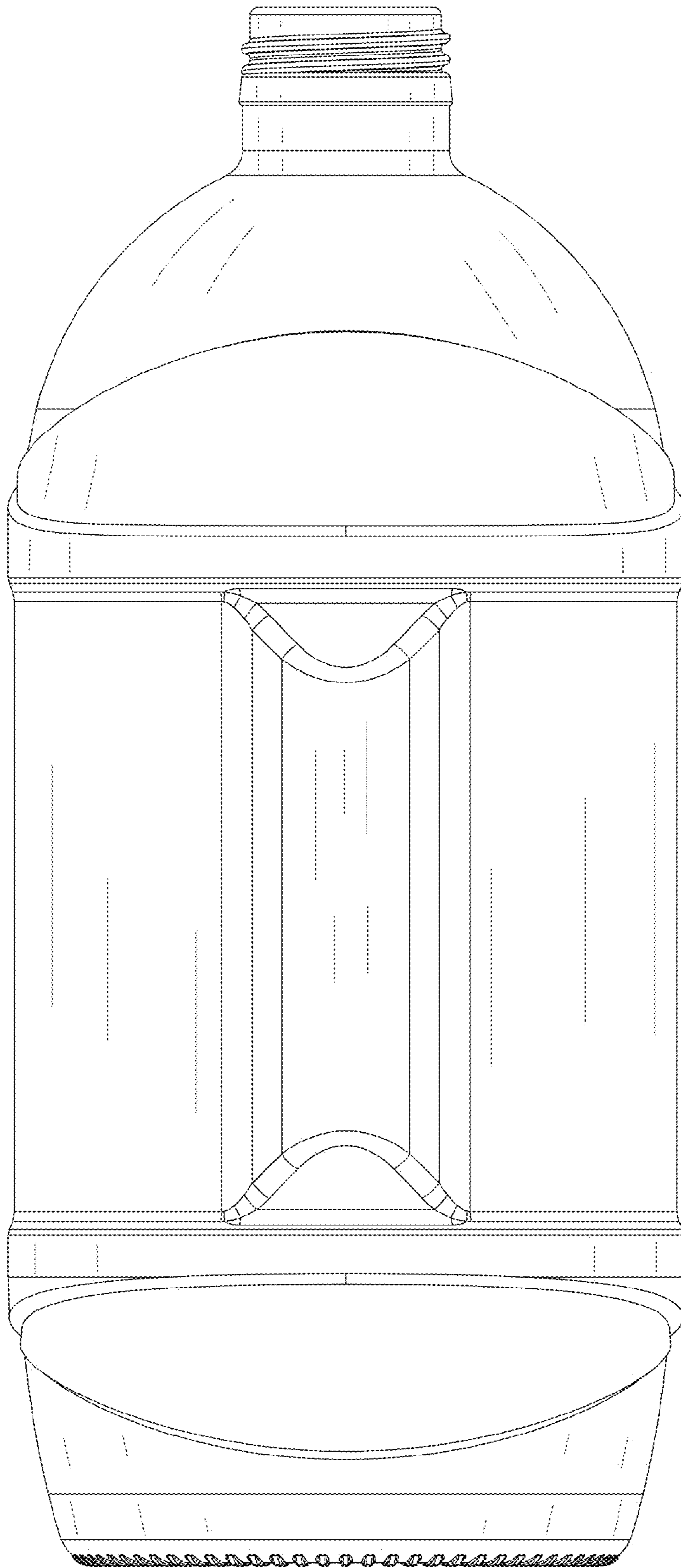

Fig. 1

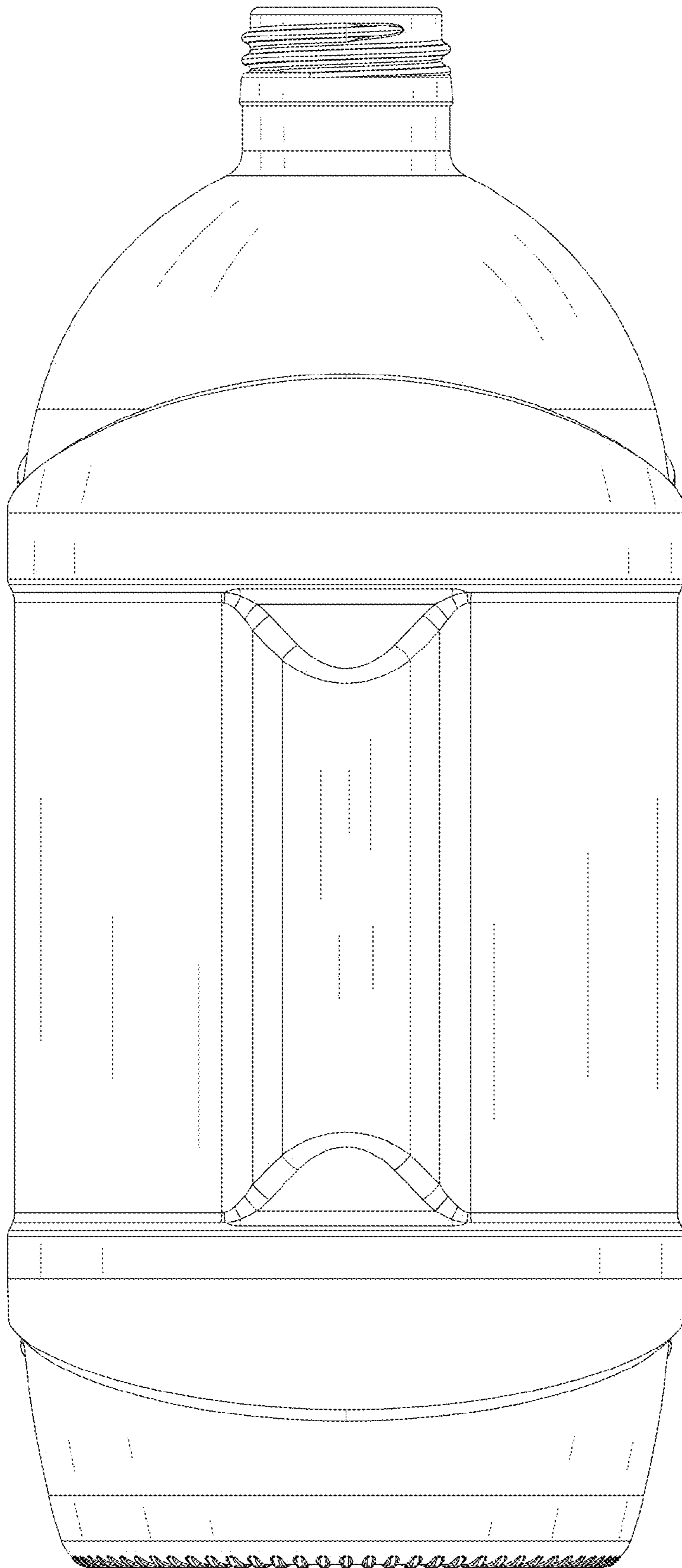

Fig. 2

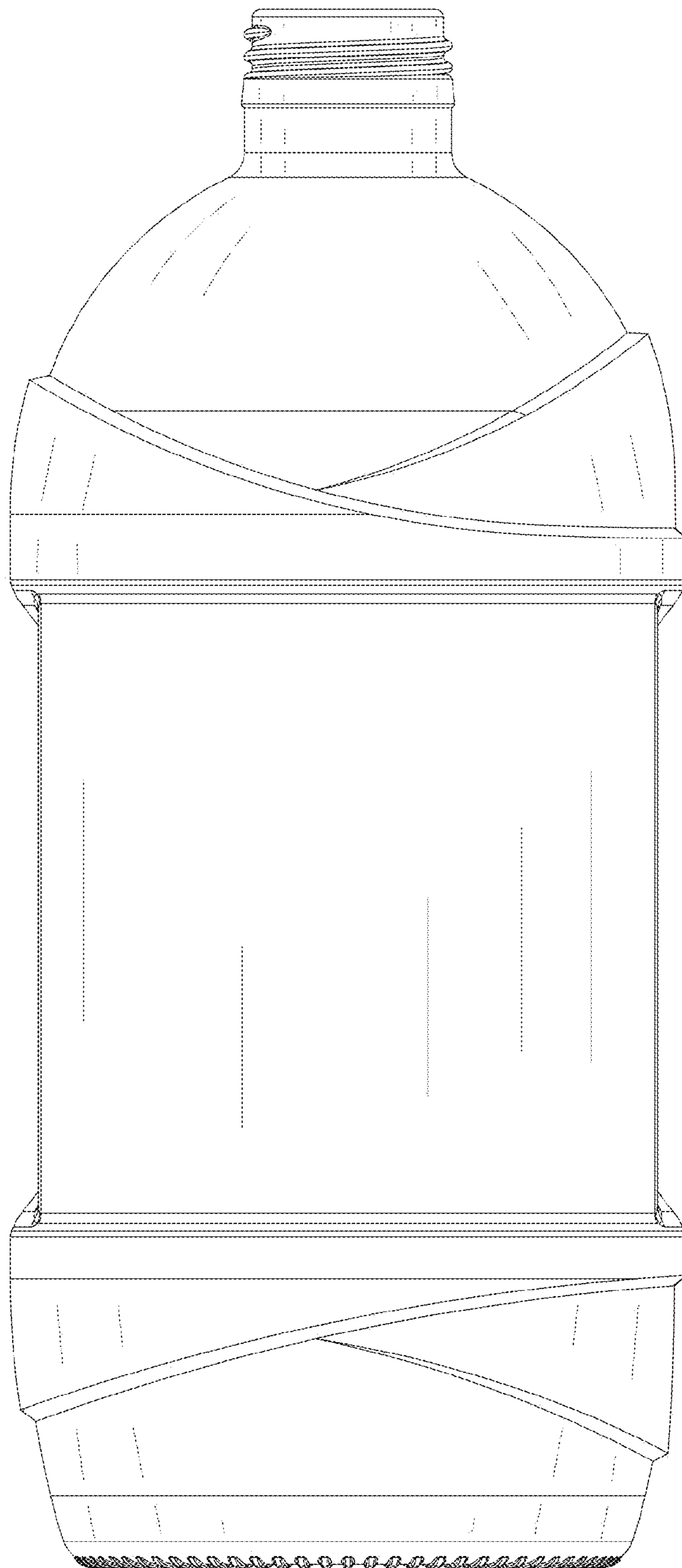

Fig. 3

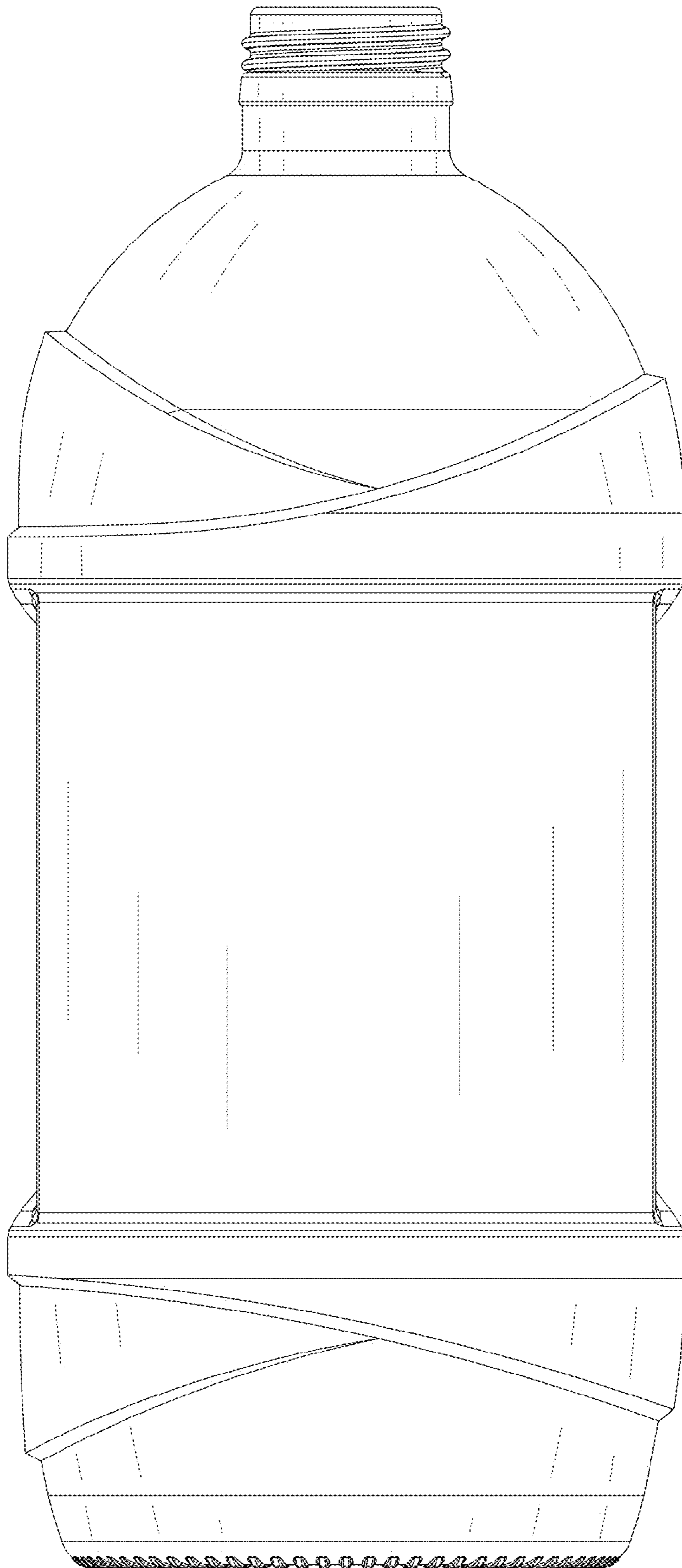

Fig. 4

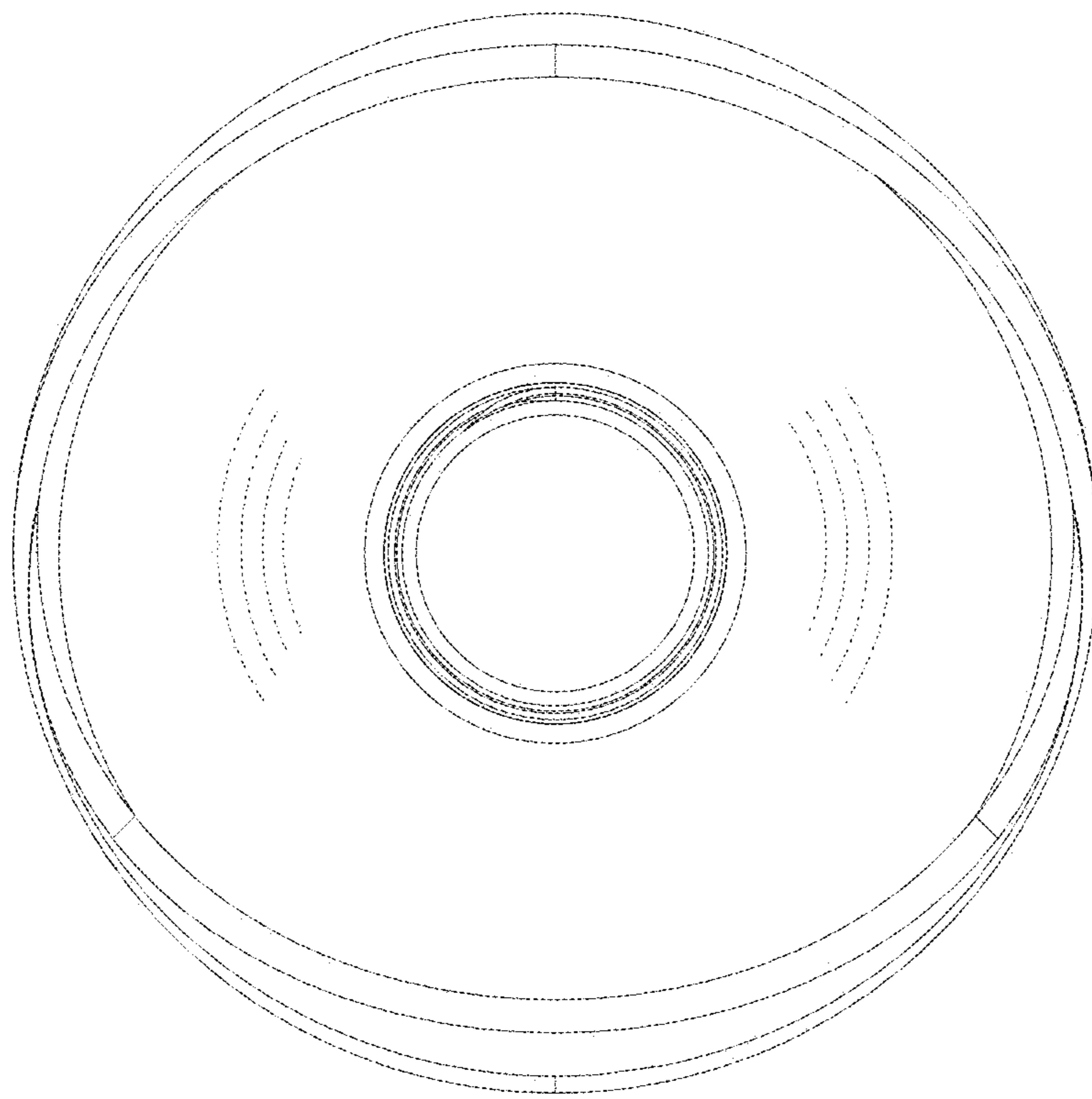

Fig. 5

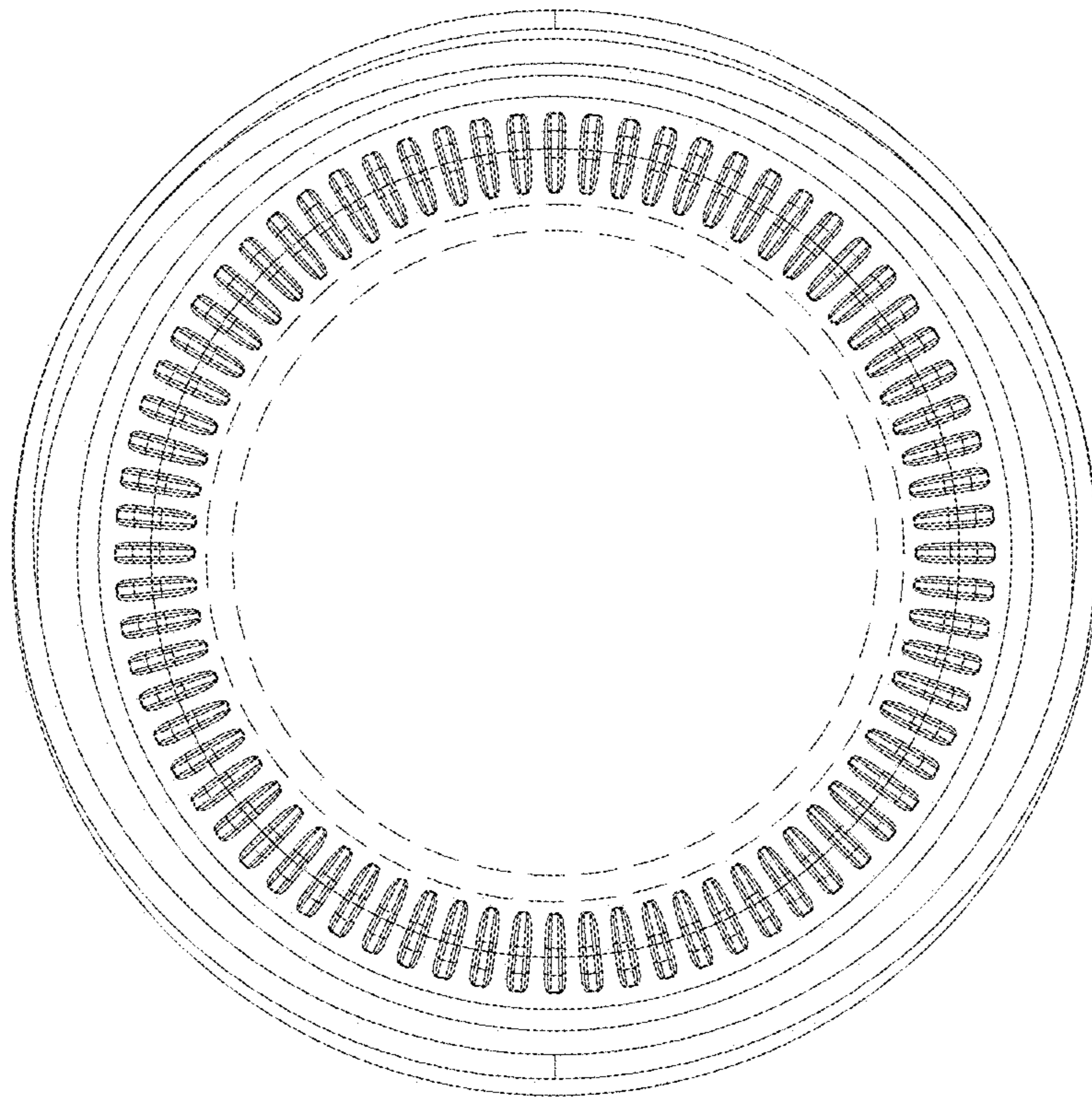

Fig. 6

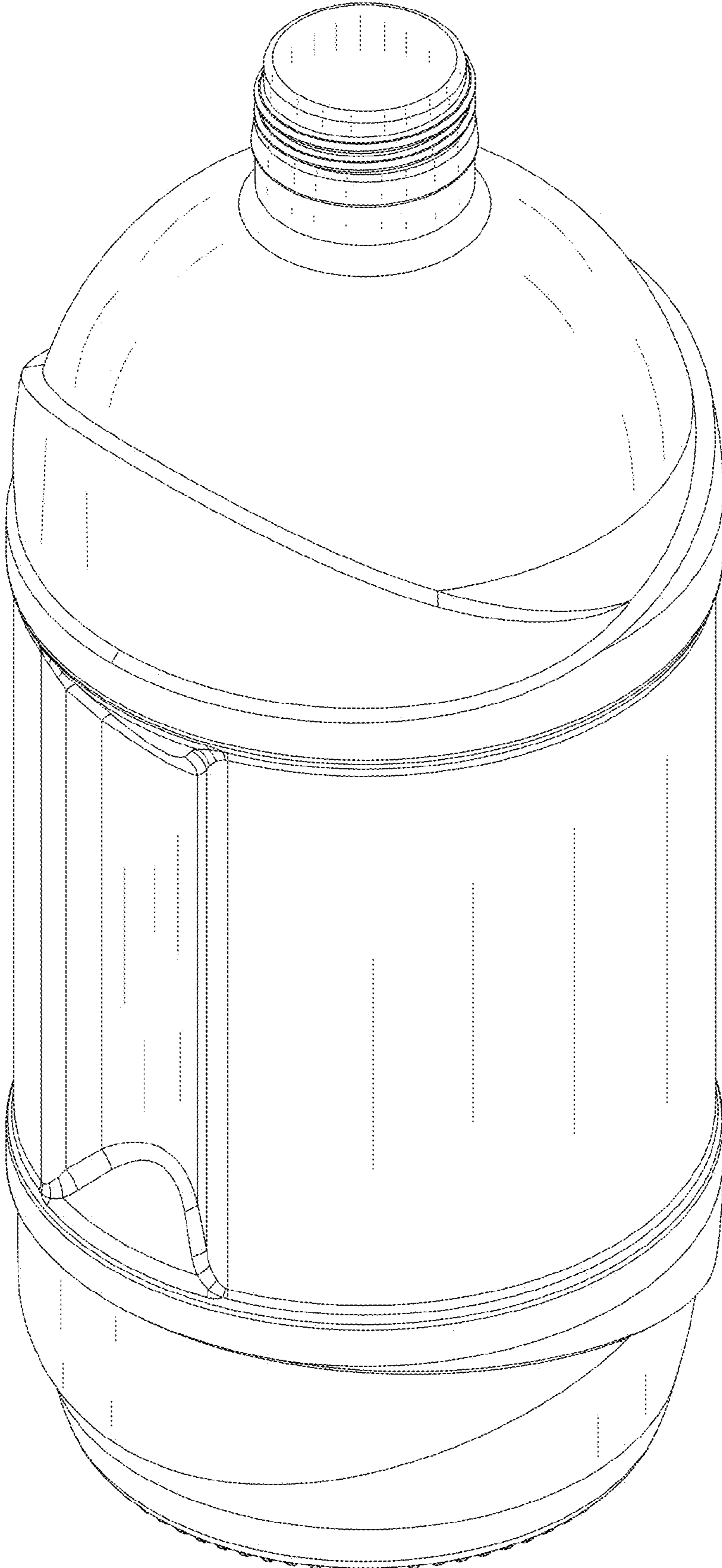

Fig. 7

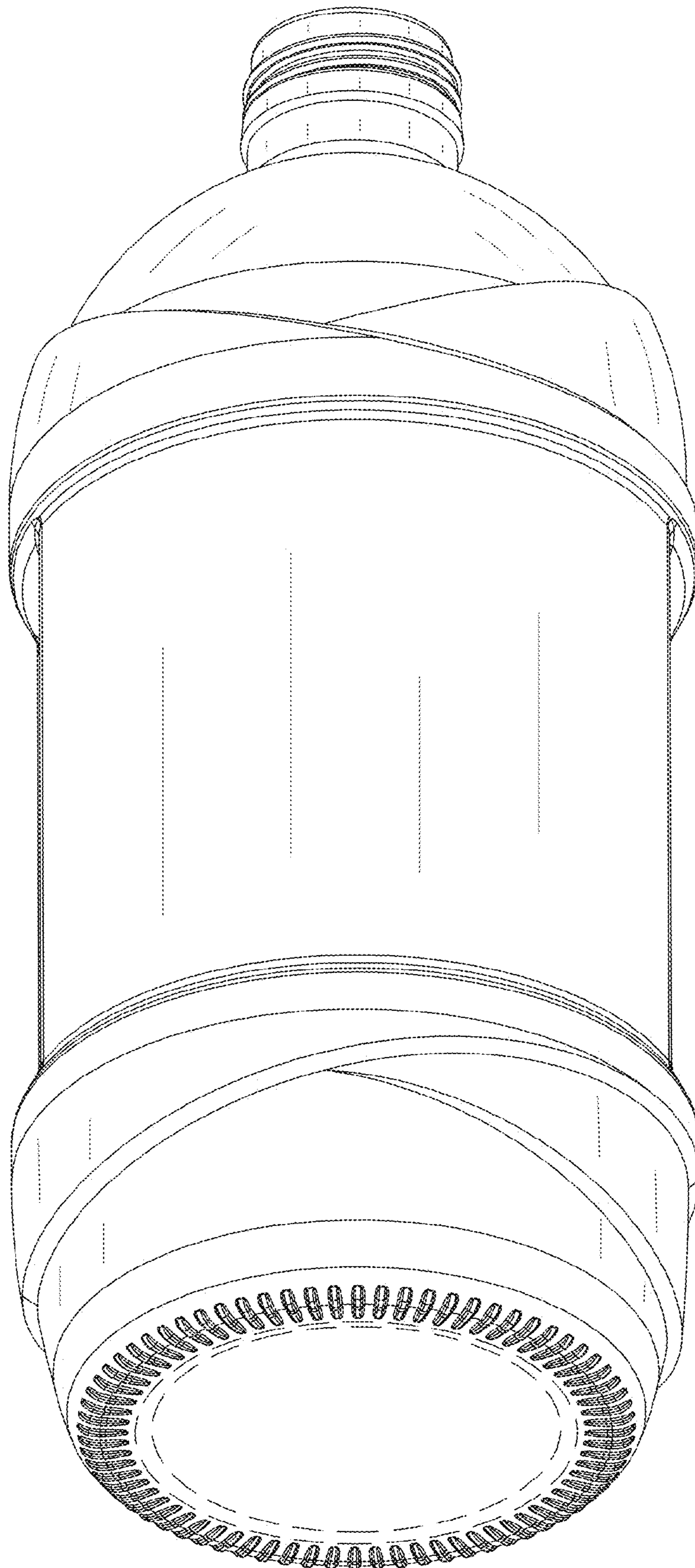

Fig. 8