

US00D871512S

(12) **United States Design Patent**
Cai

(10) **Patent No.:** **US D871,512 S**

(45) **Date of Patent:** **** Dec. 31, 2019**

(54) **REMOTE CONTROL CAR**

(71) Applicant: **Qian Hai Yong Ming Chuang Tou**
(Shen Zhen) Co., Ltd., Shenzhen
(Guangdong Province) (CN)

(72) Inventor: **Qingfu Cai**, Shenzhen (CN)

(73) Assignee: **Qian Hai Yong Ming Chuang Tou**
(Shen Zhen) Co., Ltd., Shenzhen (CN)

(**) Term: **15 Years**

(21) Appl. No.: **29/684,300**

(22) Filed: **Mar. 20, 2019**

(51) **LOC (12) Cl.** **21-01**

(52) **U.S. Cl.**
USPC **D21/550**

(58) **Field of Classification Search**
USPC D21/398, 533, 548, 549, 550, 551, 552,
D21/557, 560, 561, 562, 580, 581
CPC A63H 17/00; A63H 17/002; A63H 17/004;
A63H 17/26; A63H 17/262; A63H
17/264; A63H 17/266; A63H 17/34;
A63H 17/36; A63H 17/38; A63H 29/00;
A63H 29/16; A63H 29/165; A63H 29/22;
A63H 29/24

See application file for complete search history.

(56) **References Cited**

U.S. PATENT DOCUMENTS

D309,930 S *	8/1990	Asaeda	D21/548
D311,994 S *	11/1990	Tsuji	D21/550
D317,024 S *	5/1991	Yajima	D21/550
D425,141 S *	5/2000	Park	D21/550
D498,798 S	11/2004	Wei	
D509,264 S	9/2005	Wei	
D534,593 S *	1/2007	Yuen	D21/562
D538,861 S	3/2007	Takahashi	
D549,787 S *	8/2007	Chen	D21/548
D672,407 S *	12/2012	Nakayama	D21/550

D690,372 S *	9/2013	Fujiwara	D21/550
D771,201 S	11/2016	Tompkin	
D803,329 S	11/2017	Tompkin	
D822,126 S *	7/2018	Allmendinger	D21/562
D825,684 S	8/2018	Gan	
D825,685 S	8/2018	Tompkin	
D837,307 S *	1/2019	Jin	D21/548
D851,183 S *	6/2019	Wood	D21/562

OTHER PUBLICATIONS

Applicant's US Trademark.

Applicant's legal identity information on Amazon.

* cited by examiner

Primary Examiner — Cynthia M. Chin

(74) *Attorney, Agent, or Firm* — Yong Chen

(57) **CLAIM**

The ornamental design for a remote control car, as shown and described.

DESCRIPTION

FIG. 1 is a front view of a remote control car of the present invention.

FIG. 2 is a rear view thereof.

FIG. 3 is a left view thereof.

FIG. 4 is a right view thereof.

FIG. 5 is a top view thereof.

FIG. 6 is a bottom view thereof.

FIG. 7 is a perspective view thereof.

FIG. 8 is a second perspective view thereof.

FIG. 9 is a third perspective view thereof.

FIG. 10 is a fourth perspective view thereof.

FIG. 11 is a fifth perspective view thereof; and,

FIG. 12 is a sixth perspective view thereof.

The broken lines shown are included for the purpose of illustrating portions of the remote control car which form no part of the claimed design.

1 Claim, 12 Drawing Sheets

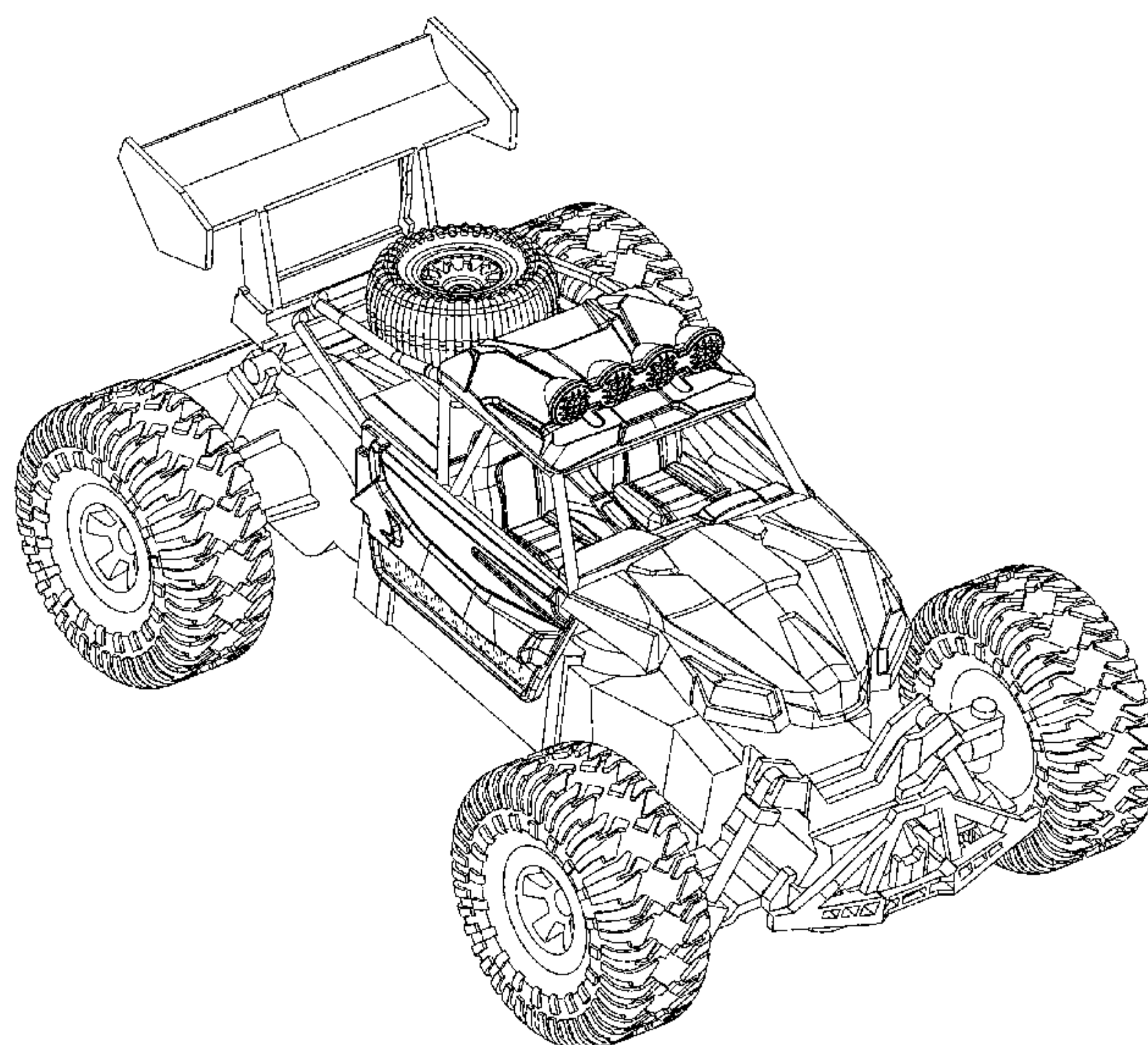

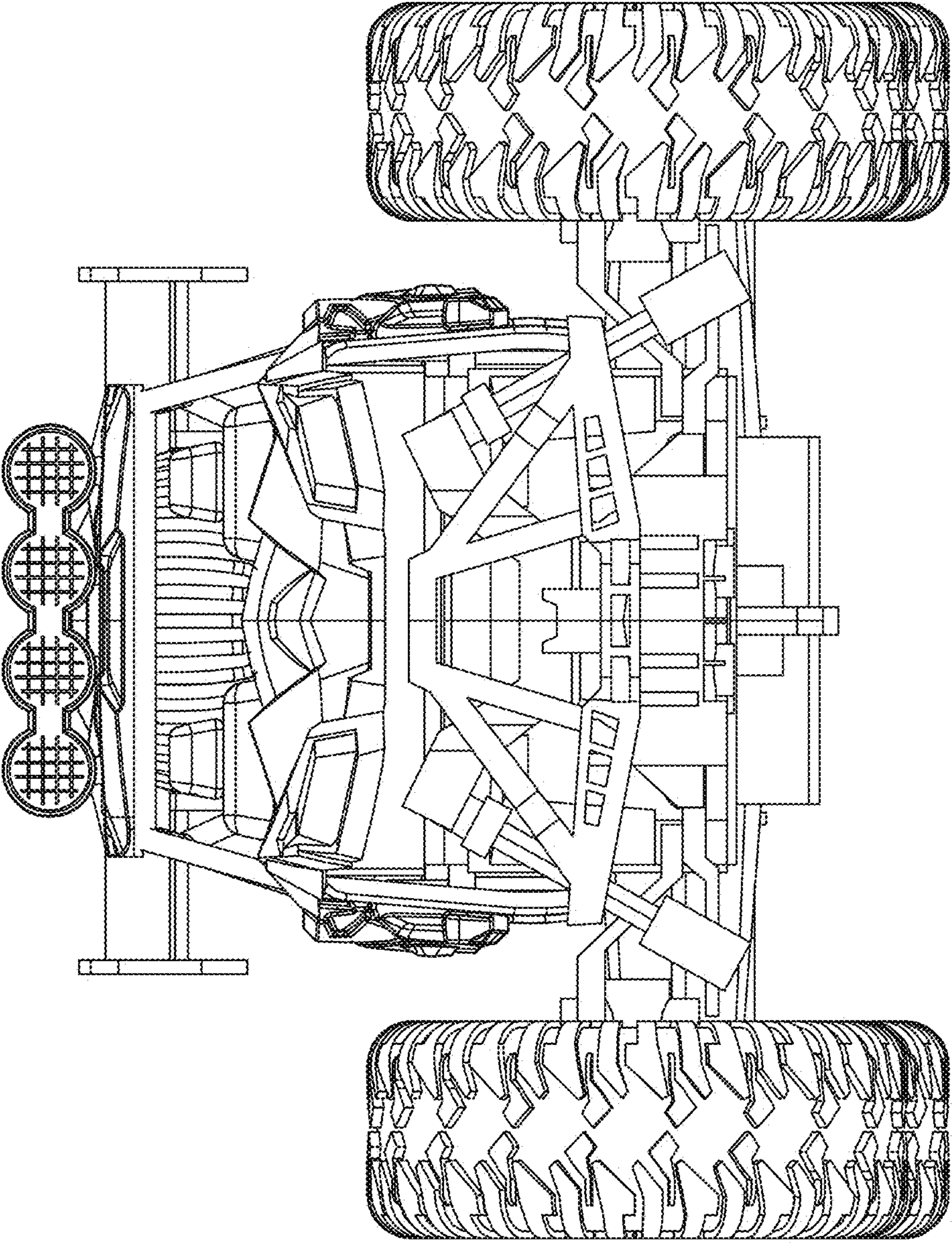

FIG. 1

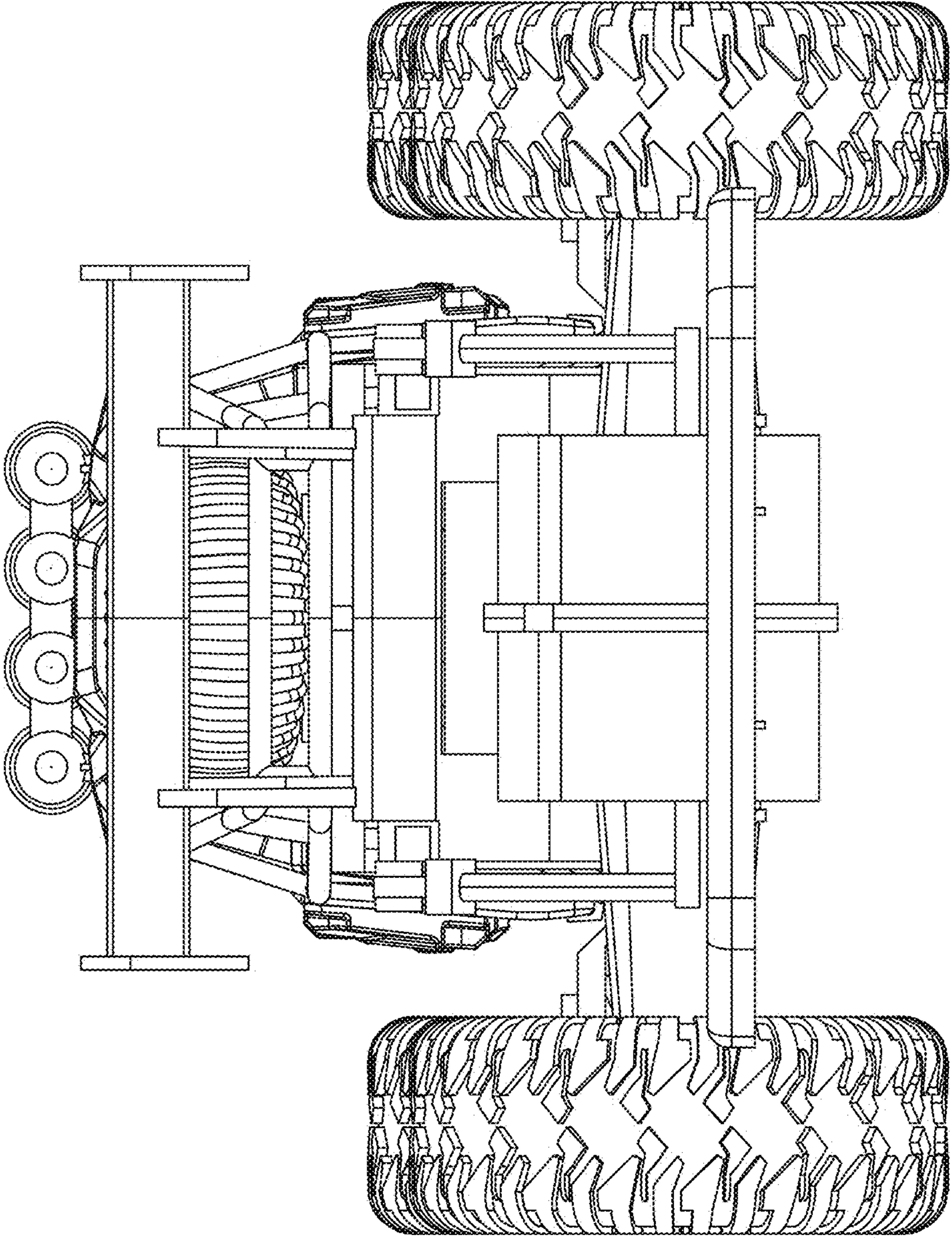

FIG. 2

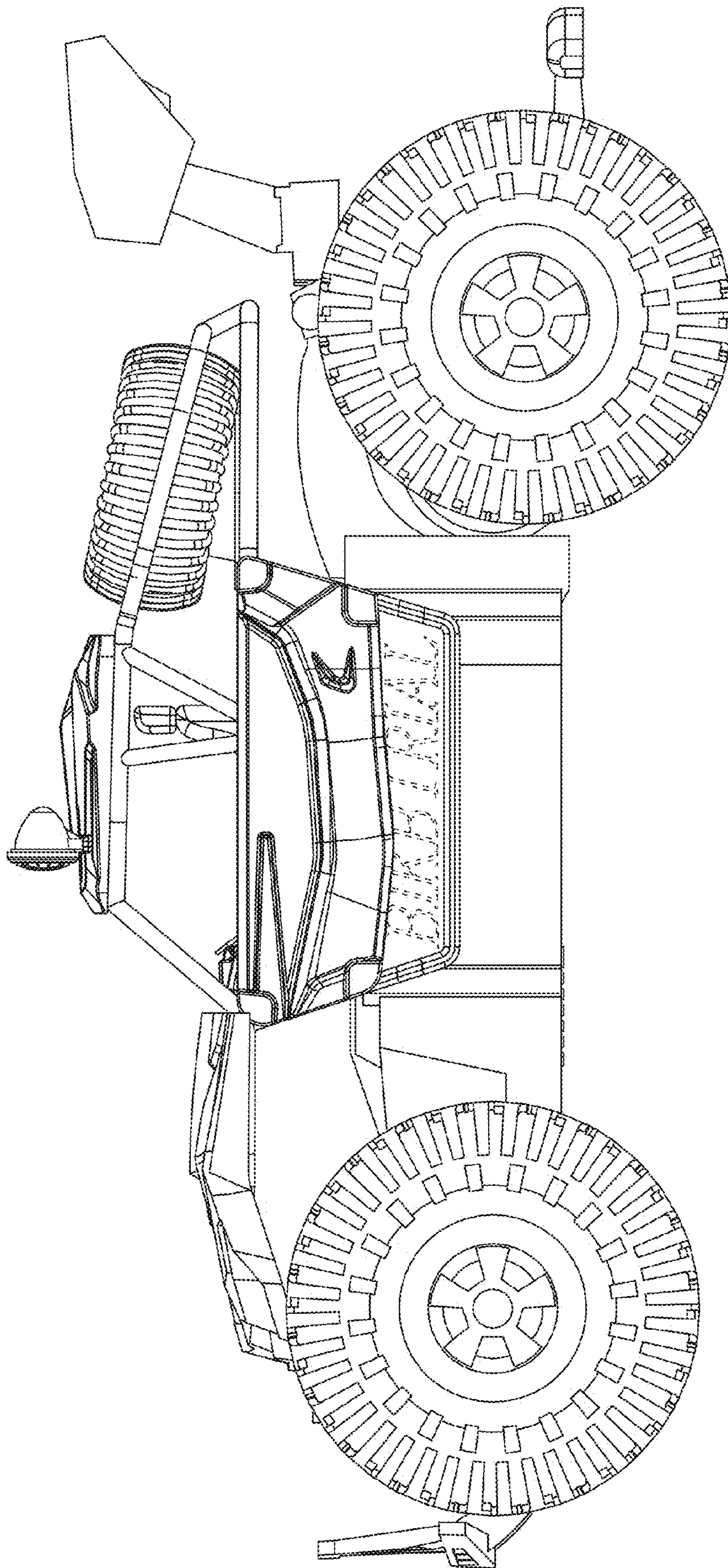

FIG. 3

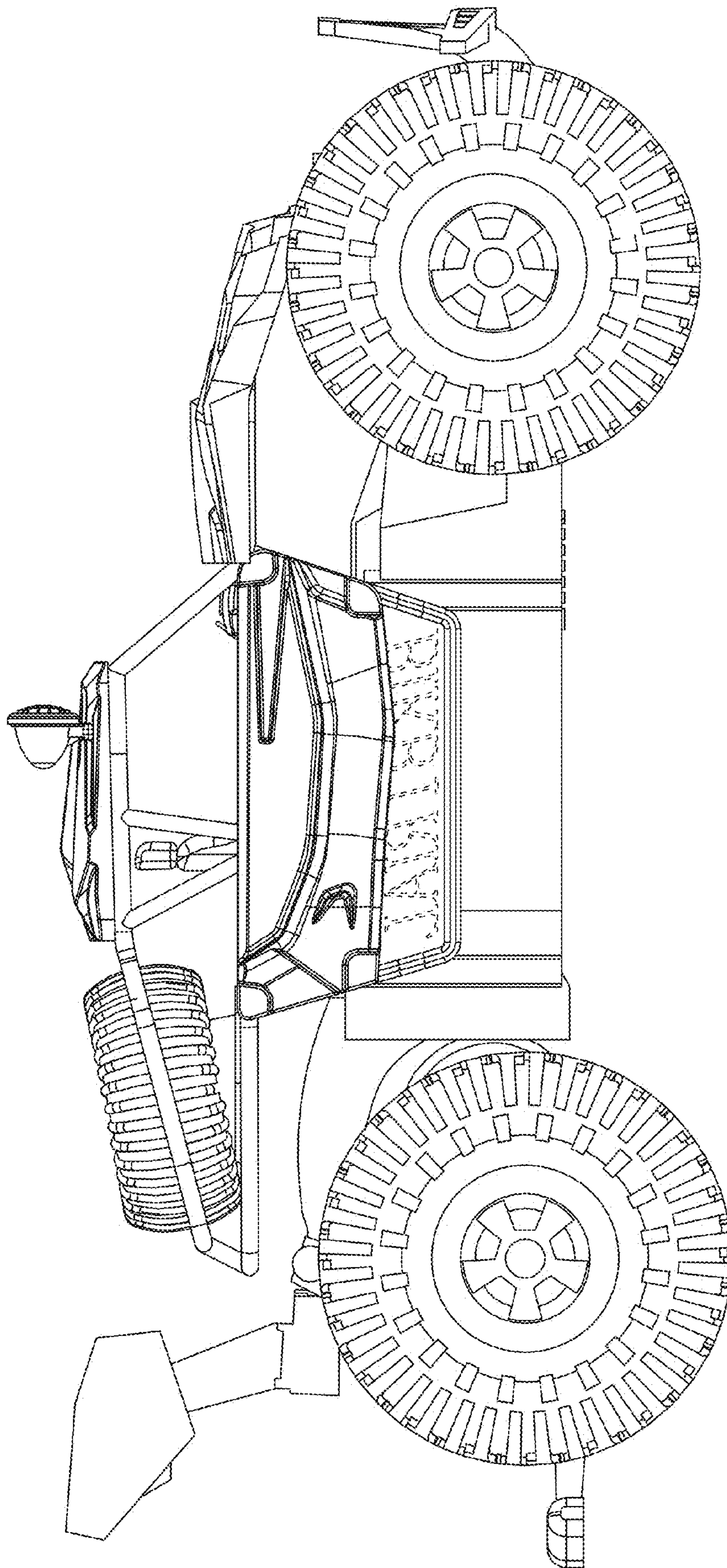

FIG. 4

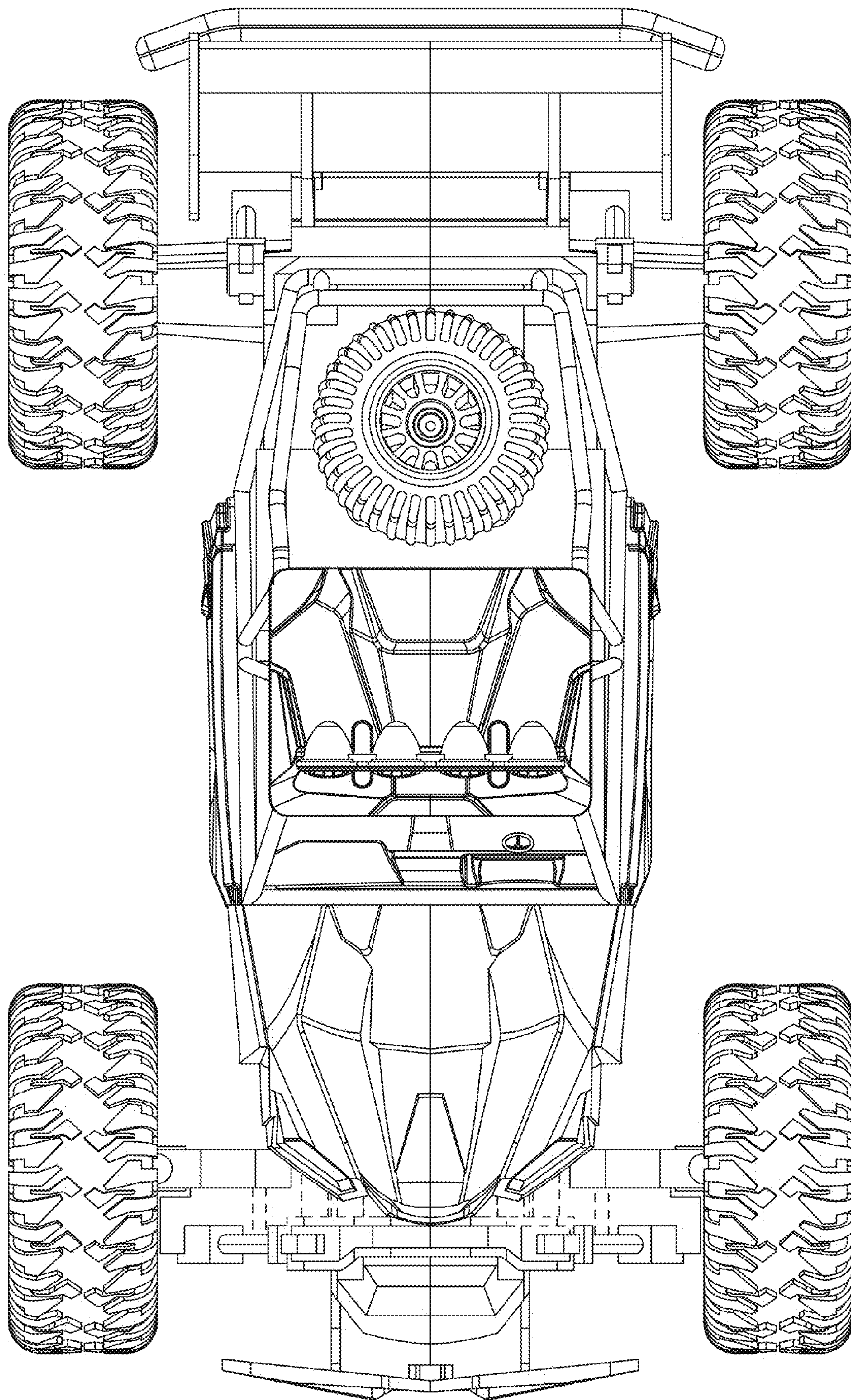

FIG. 5

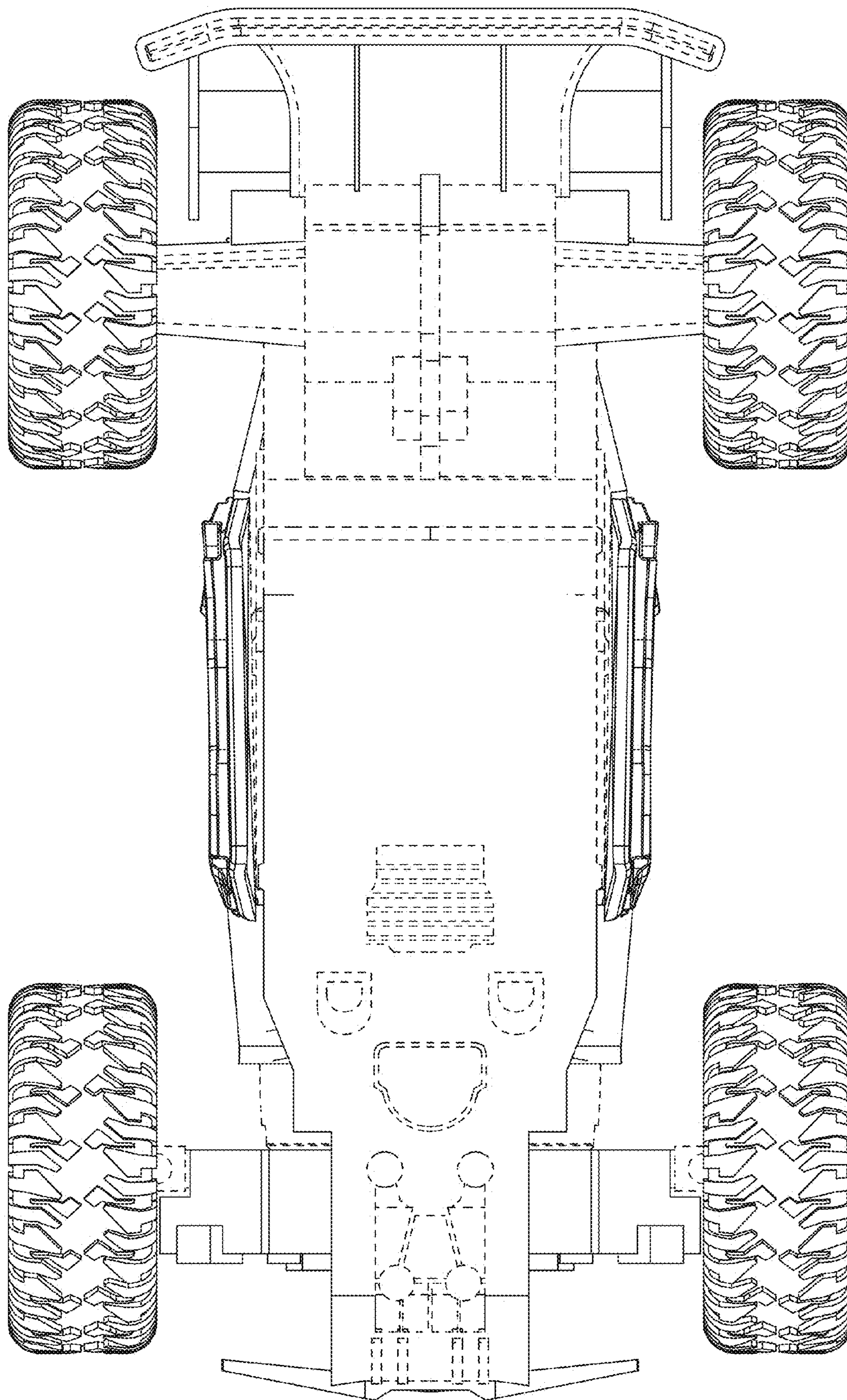

FIG. 6

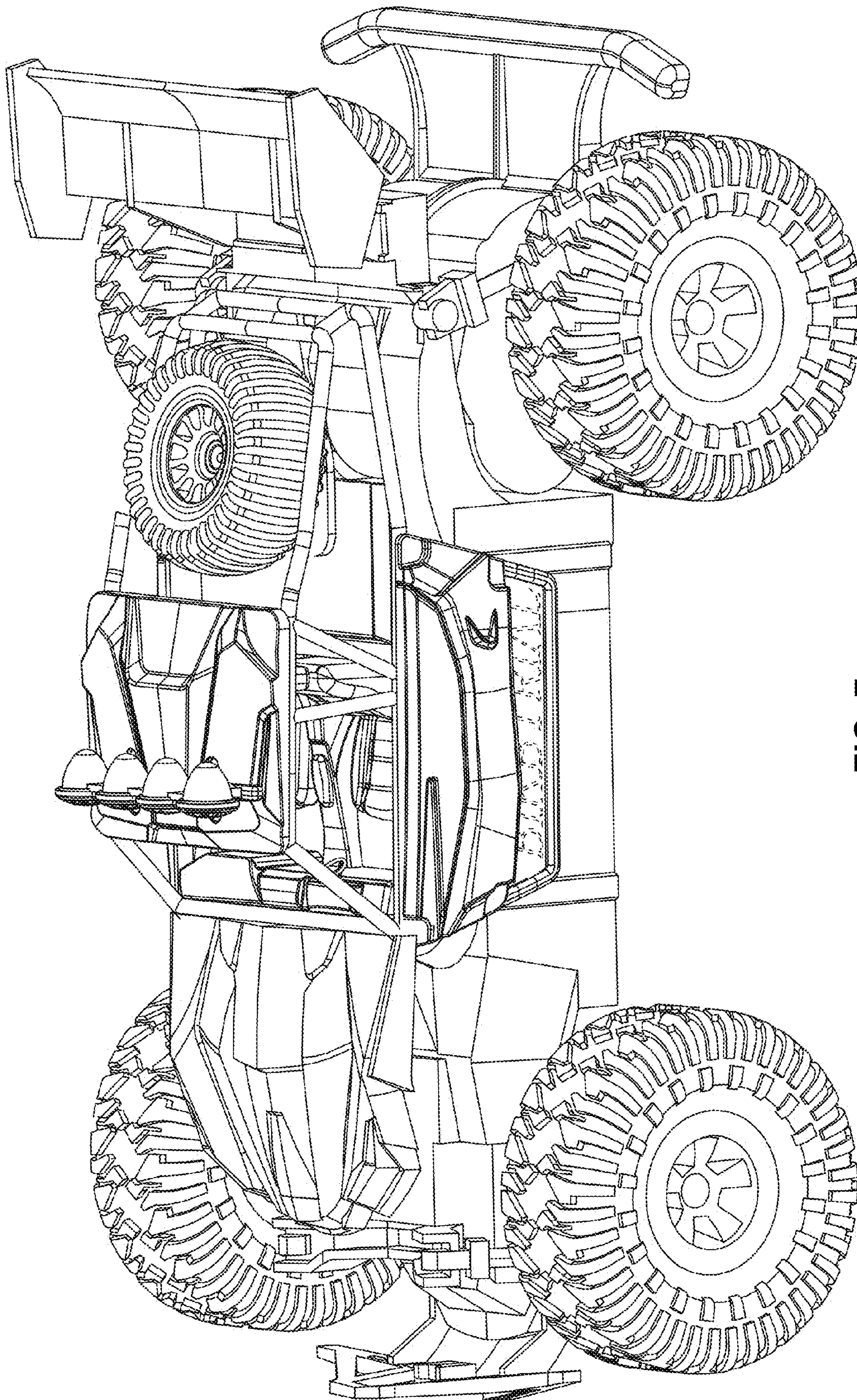

FIG. 7

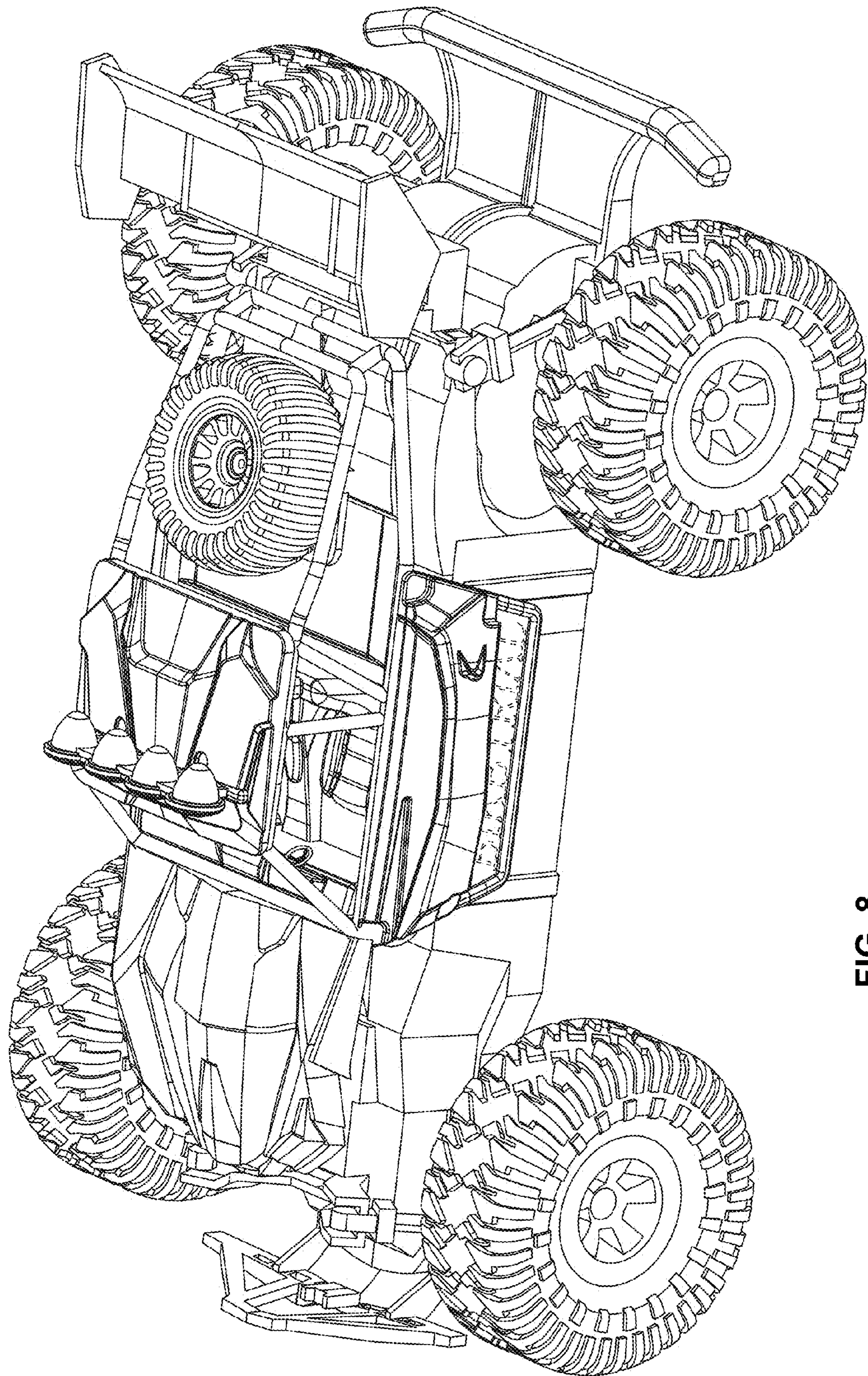

FIG. 8

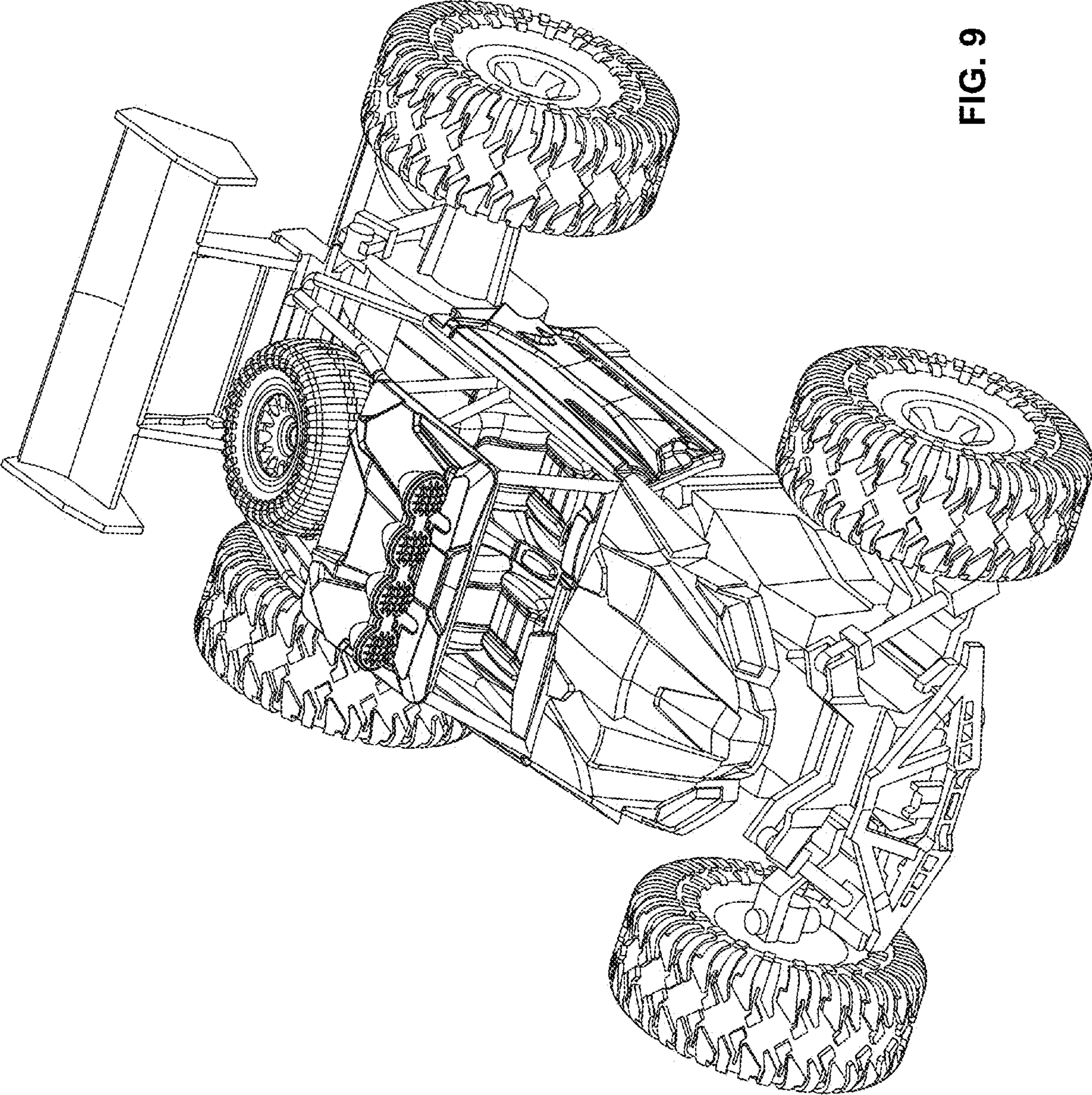

FIG. 9

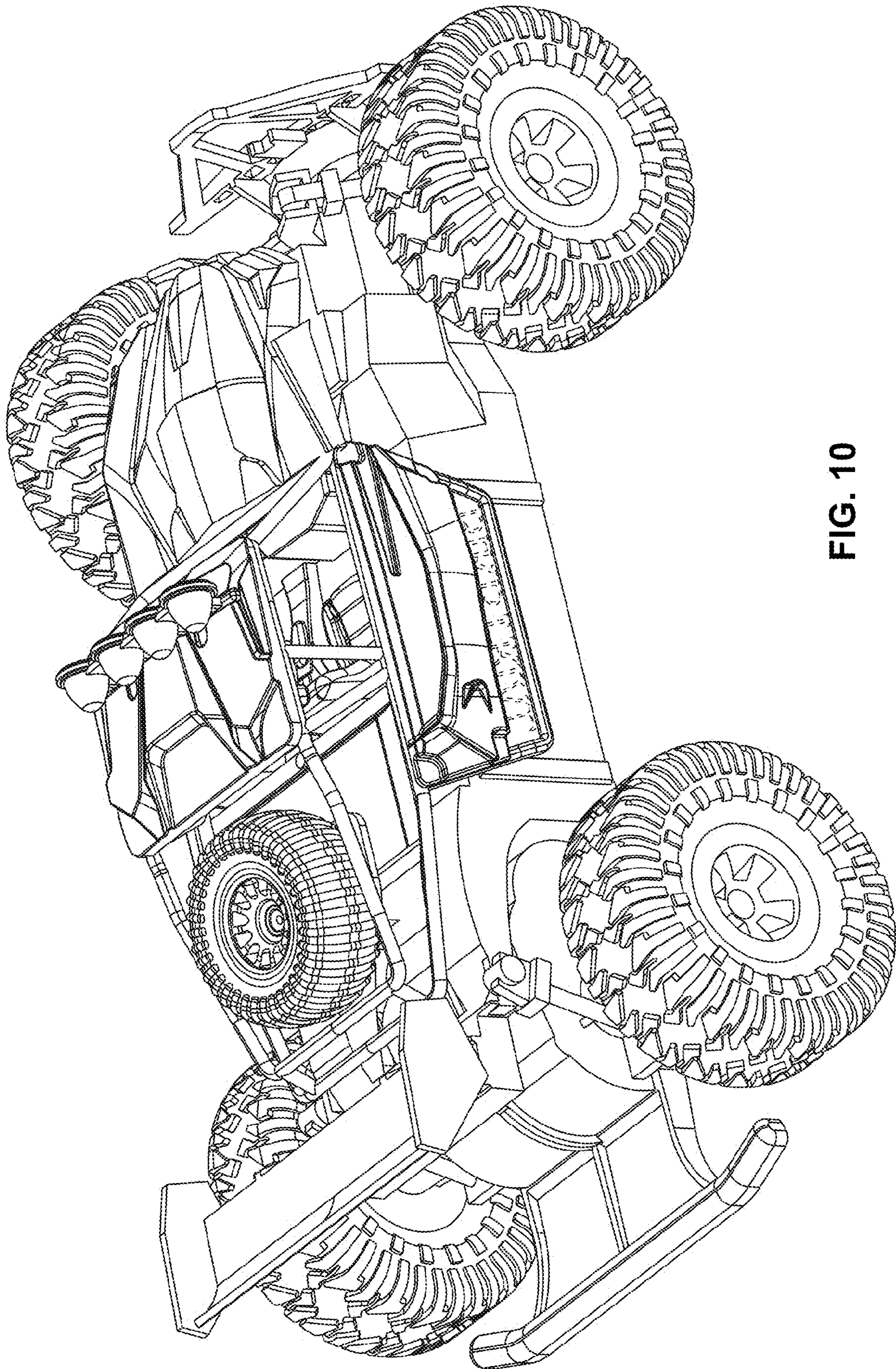

FIG. 10

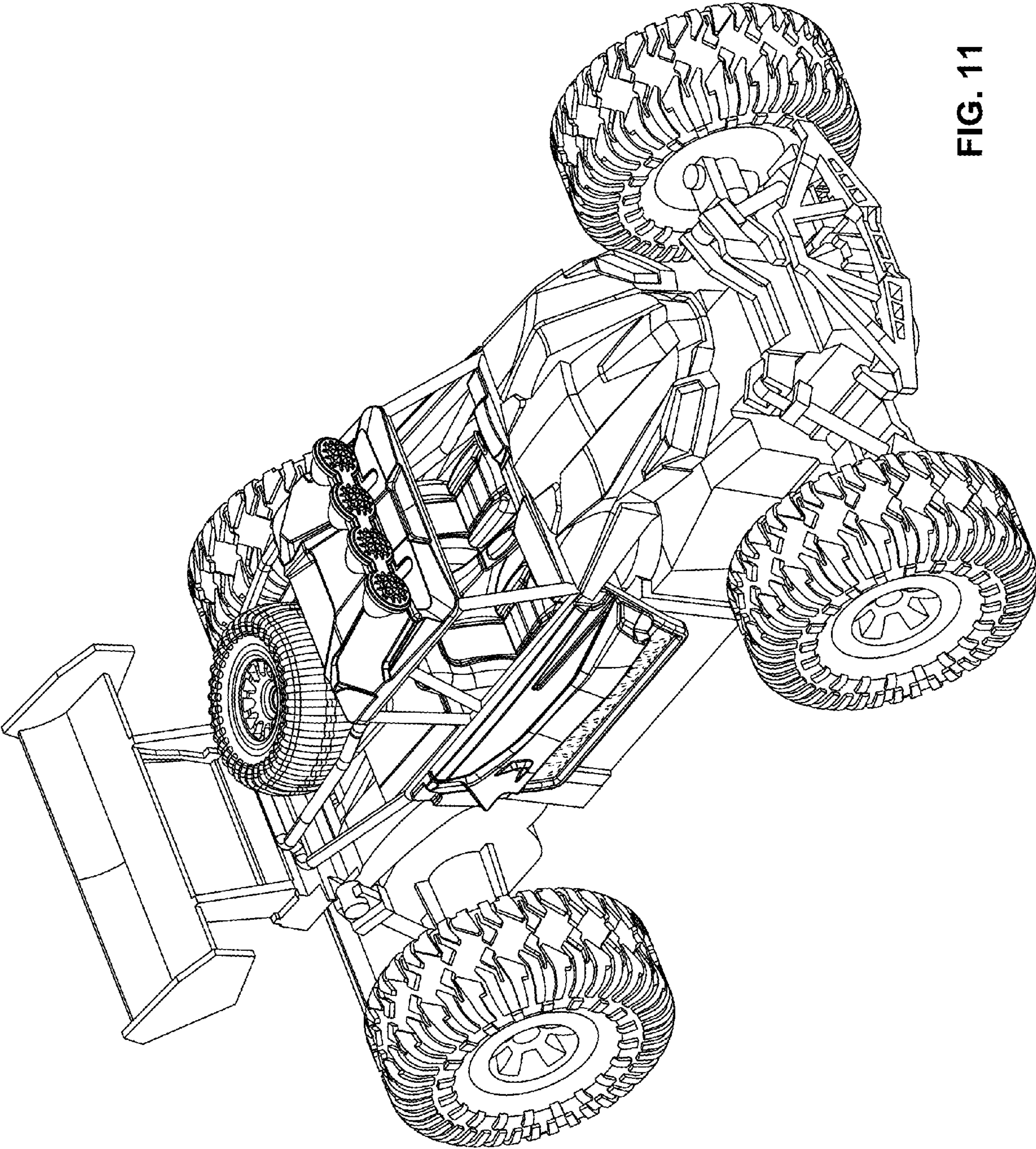

FIG. 11

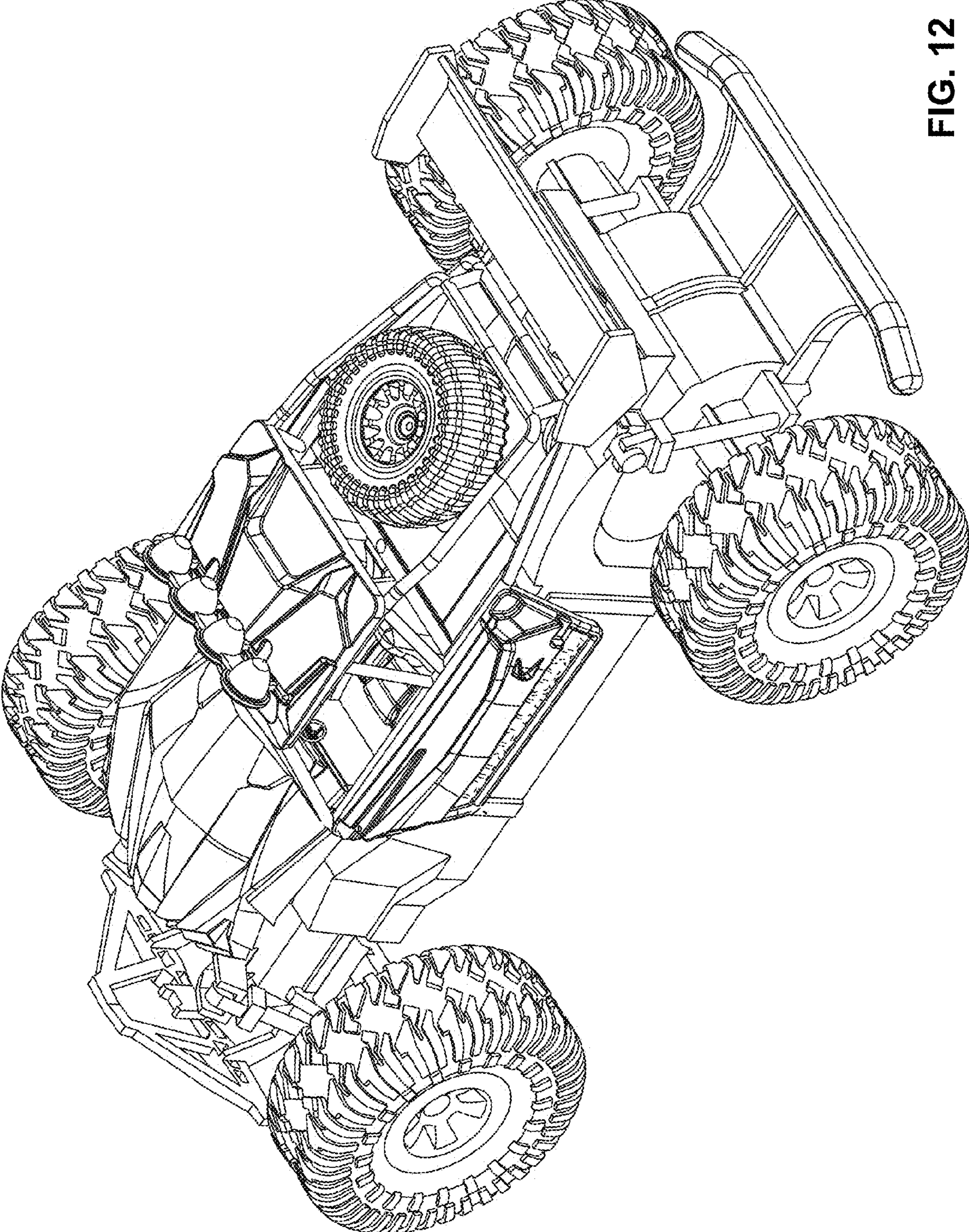

FIG. 12