



US00D871461S

(12) **United States Design Patent**  
**Lee**

(10) **Patent No.:** **US D871,461 S**  
(45) **Date of Patent:** **\*\* Dec. 31, 2019**

(54) **HYDRAULIC BREAKER**

(71) Applicant: **Il Jae Lee**, Suwon-si (KR)

(72) Inventor: **Il Jae Lee**, Suwon-si (KR)

(\*\*) Term: **15 Years**

(21) Appl. No.: **29/607,872**

(22) Filed: **Jun. 16, 2017**

(51) **LOC (12) Cl.** ..... **15-04**

(52) **U.S. Cl.**

USPC ..... **D15/21**

(58) **Field of Classification Search**

USPC ..... D15/10, 21, 28, 199

CPC ..... E21B 25/02; E21B 25/00; E21B 21/103;

E21B 10/02; E21B 21/003; E21B 49/02;

E21B 4/18; E21B 10/48

See application file for complete search history.

(56) **References Cited**

**U.S. PATENT DOCUMENTS**

3,792,738 A \* 2/1974 Mori ..... B25D 9/12

173/202

6,227,307 B1 \* 5/2001 Lee ..... B25D 17/11

173/162.1

D457,534 S \* 5/2002 Kim ..... D15/21

8,146,677 B2 \* 4/2012 Kim ..... B25D 17/00

173/115

8,776,911 B2 \* 7/2014 Lee ..... E02F 3/966

173/115

9,289,889 B2 \* 3/2016 Pettersson ..... B25D 9/145

D782,542 S \* 3/2017 Holland, Jr. .... D15/21

\* cited by examiner

*Primary Examiner* — Mark A Goodwin

*Assistant Examiner* — Benjamin M Weeks

(74) *Attorney, Agent, or Firm* — Rabin & Berdo, P.C.

(57) **CLAIM**

The ornamental design for a hydraulic breaker, as shown and described.

**DESCRIPTION**

FIG. 1 is a perspective view showing a hydraulic breaker;

FIG. 2 is a front elevational view thereof;

FIG. 3 is a rear elevational view thereof;

FIG. 4 is a left side elevational view thereof;

FIG. 5 is a right side elevational view thereof;

FIG. 6 is top plan view thereof; and,

FIG. 7 is a bottom plan view thereof.

**1 Claim, 7 Drawing Sheets**

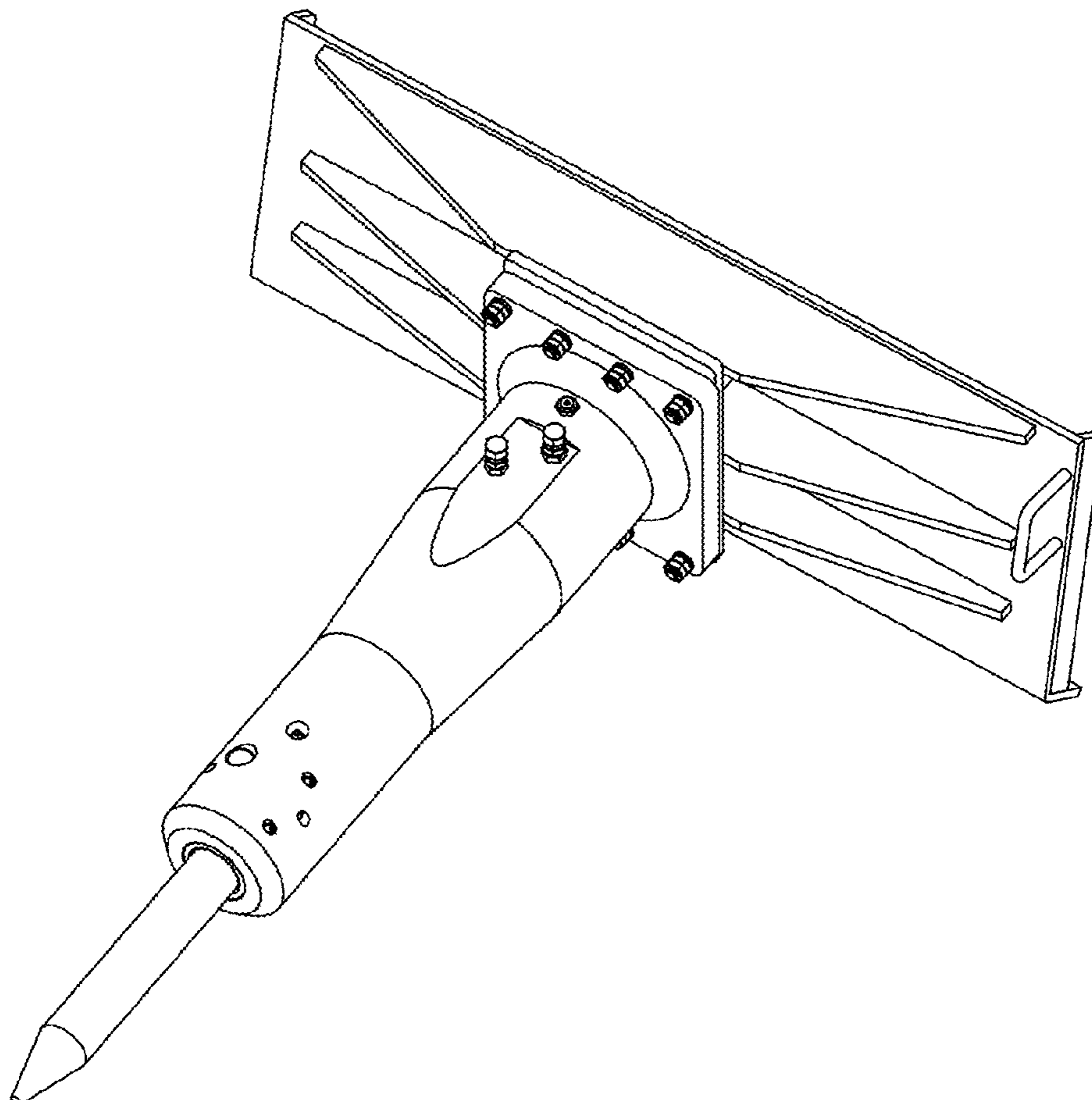

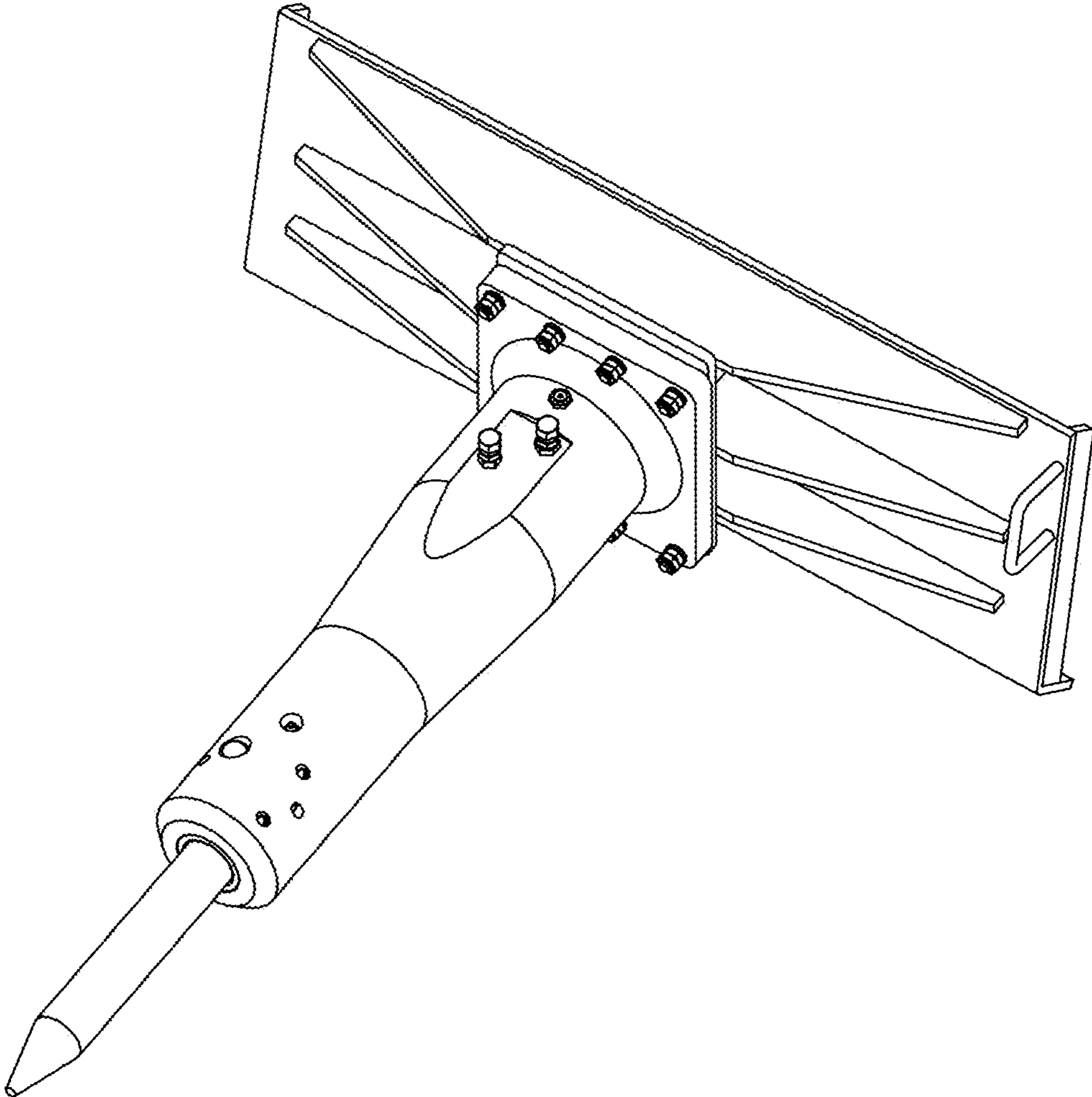

FIG. 1

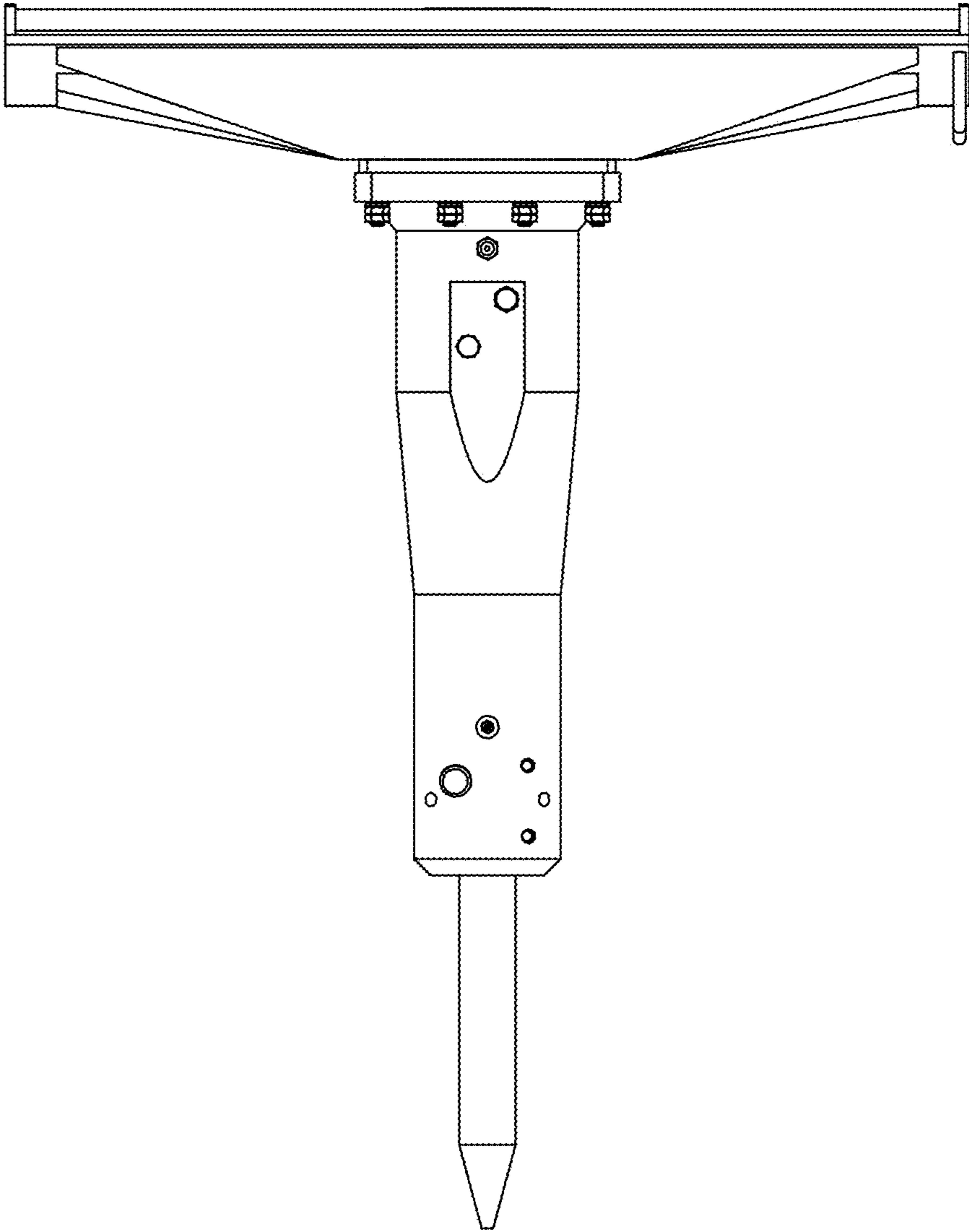

FIG. 2

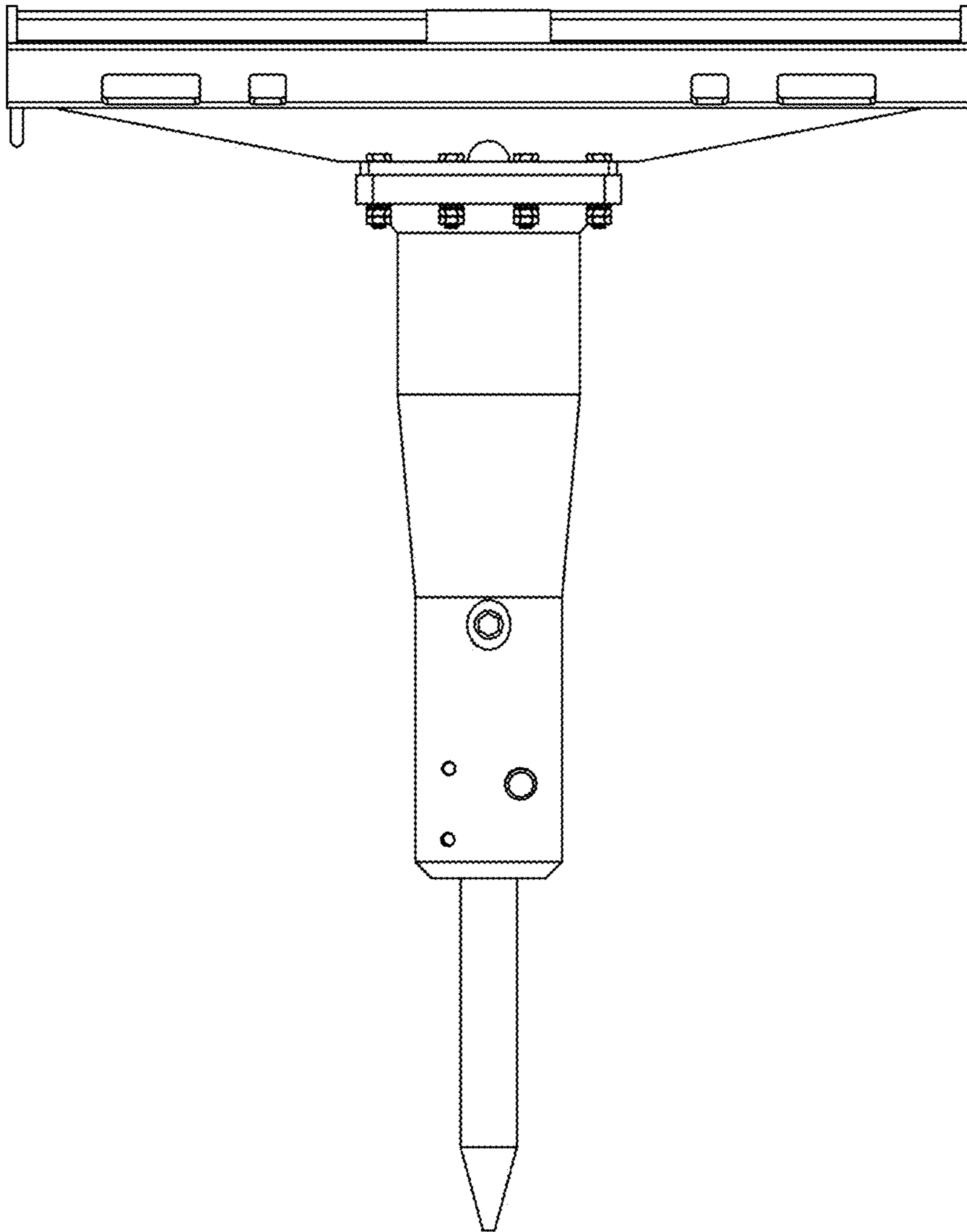

FIG. 3

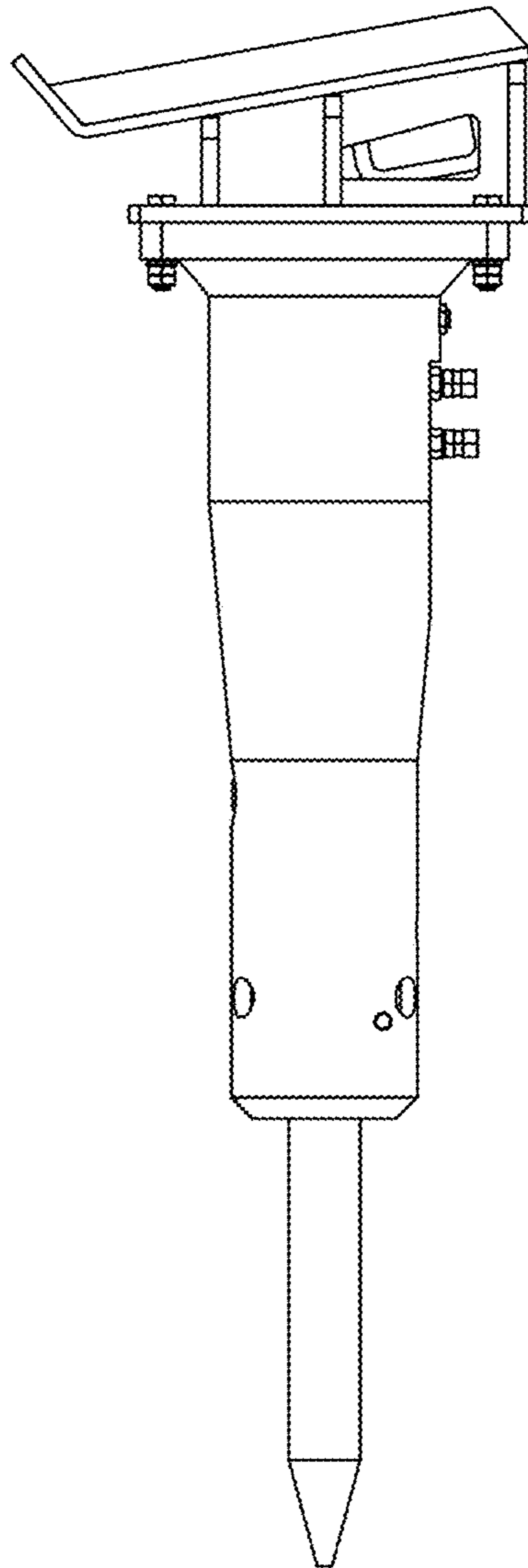

FIG. 4

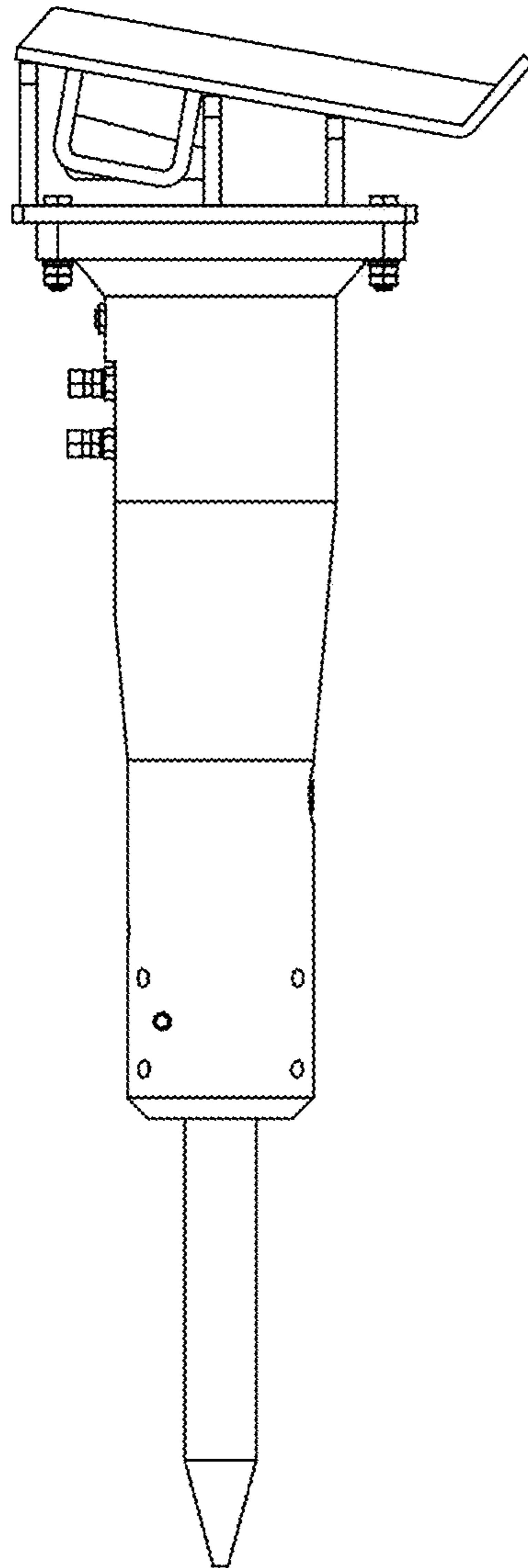

FIG. 5

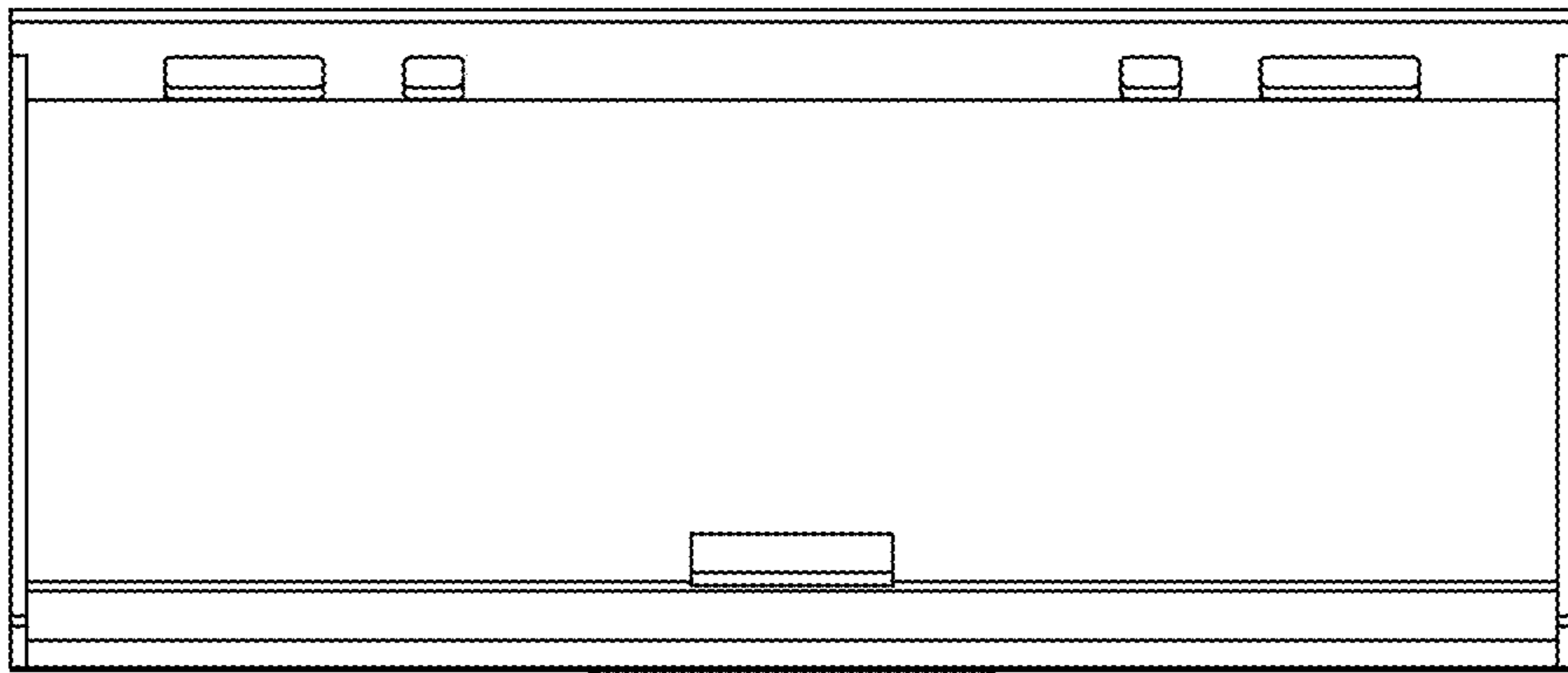

FIG. 6

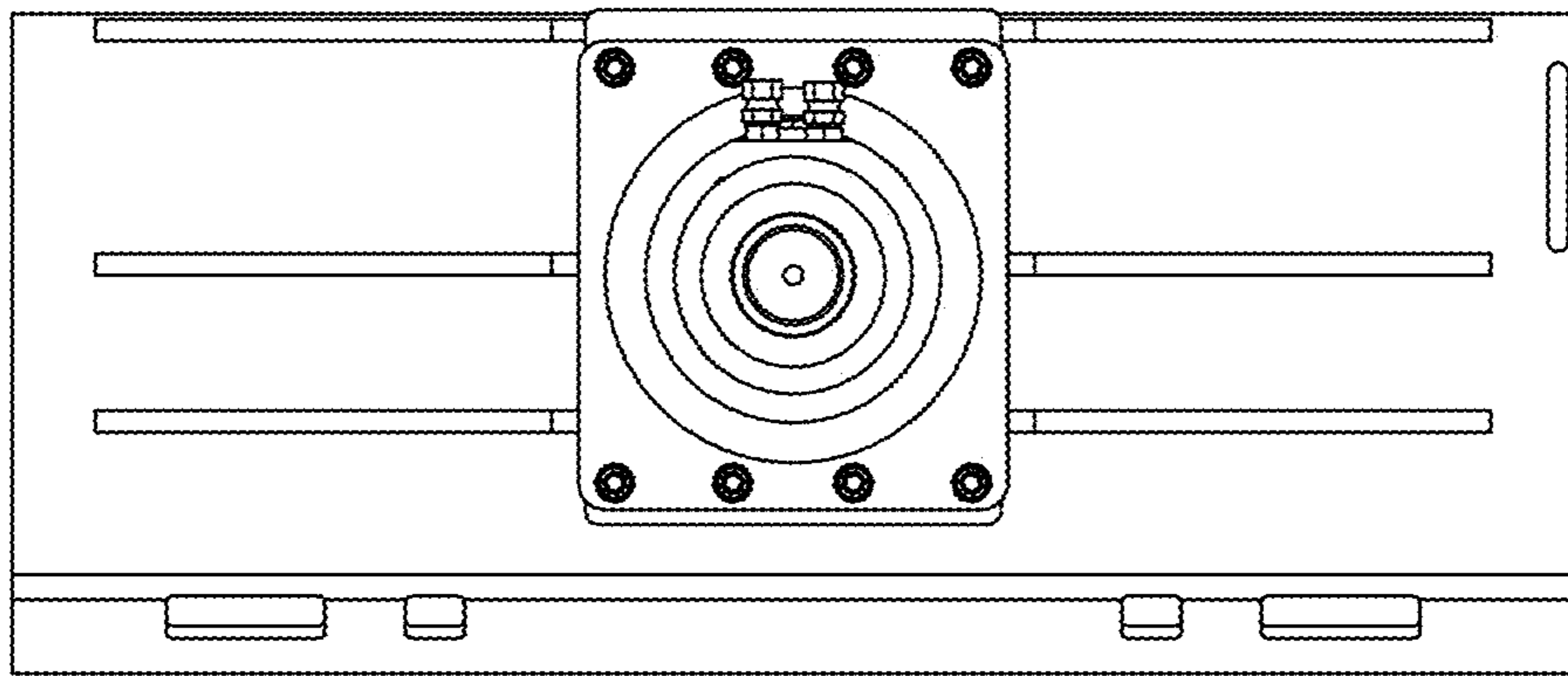

FIG. 7