

US00D871339S

(12) **United States Design Patent** (10) **Patent No.:** **US D871,339 S**
Yang (45) **Date of Patent:** **** *Dec. 31, 2019**

(54) **BATTERY CASE**
(71) Applicant: **Jetmax Lighting Industrial Co., Limited**, Dongguan (CN)
(72) Inventor: **Ping Yang**, Dongguan (CN)
(73) Assignee: **Jetmax Lighting Industrial Co., Limited**, Guangdong (CN)
(*) Notice: This patent is subject to a terminal disclaimer.
(**) Term: **15 Years**
(21) Appl. No.: **29/601,365**
(22) Filed: **Apr. 21, 2017**
(51) **LOC (12) Cl.** **13-02**
(52) **U.S. Cl.**
USPC **D13/119**; D3/295
(58) **Field of Classification Search**
USPC D3/294, 295, 315, 316; D13/103, 119, D13/184; D26/113; 429/96-100, 163, 429/164, 177; 220/4.01, 507, 524
CPC B65D 83/0445; B65D 2585/56; B65D 25/04; B65D 2251/0003; B65D 75/327; H01M 2/105; H01M 2/1016; H01M 2/1077; H01M 2/24; H01M 10/425; B01L 2300/043; B29L 2031/7146
See application file for complete search history.

D337,725 S * 7/1993 Bunin D3/203.3
5,601,942 A * 2/1997 Fedele H01M 2/1061
29/623.4
5,686,811 A * 11/1997 Bushong H02J 7/0042
320/110

(Continued)

FOREIGN PATENT DOCUMENTS

CN 303912049 * 11/2016
CN 303930743 * 11/2016
CN 304498772 * 2/2018

OTHER PUBLICATIONS

Battery Compartment Door, available Mar. 22, 2019, [online], [site visited Mar. 22, 2019]. Available from internet, <URL: <https://www.dollarhobbyz.com/collections/batteries-charging/products/traxxas-battery-compartment-door-7026> (Year: 2019).*

Primary Examiner — W. A. Teddy Falloway
(74) *Attorney, Agent, or Firm* — C. G. Mersereau; DeWitt LLP

(57) **CLAIM**

The ornamental design for a battery case, as shown and described.

DESCRIPTION

FIG. 1 is a perspective view of a battery case, showing my new design;
FIG. 2 is another perspective view thereof;
FIG. 3 is a front view thereof;
FIG. 4 is a rear view thereof;
FIG. 5 is a left side view thereof;
FIG. 6 is a right side view thereof;
FIG. 7 is a top view thereof;
FIG. 8 is a bottom view thereof; and,
FIG. 9 is a perspective view thereof, shown in an open state. The broken lines shown illustrate portions of the battery case that form no part of the claimed design.

1 Claim, 9 Drawing Sheets

(56) **References Cited**

U.S. PATENT DOCUMENTS

3,061,136 A * 10/1962 Sterngart A45C 11/00
220/23.8
D227,552 S * 7/1973 Bridges D3/203.3
D264,519 S * 5/1982 Birtcil D3/23
4,766,361 A * 8/1988 Pusateri H02J 7/0006
320/110
5,163,559 A * 11/1992 Bunin B65D 50/06
206/1.5

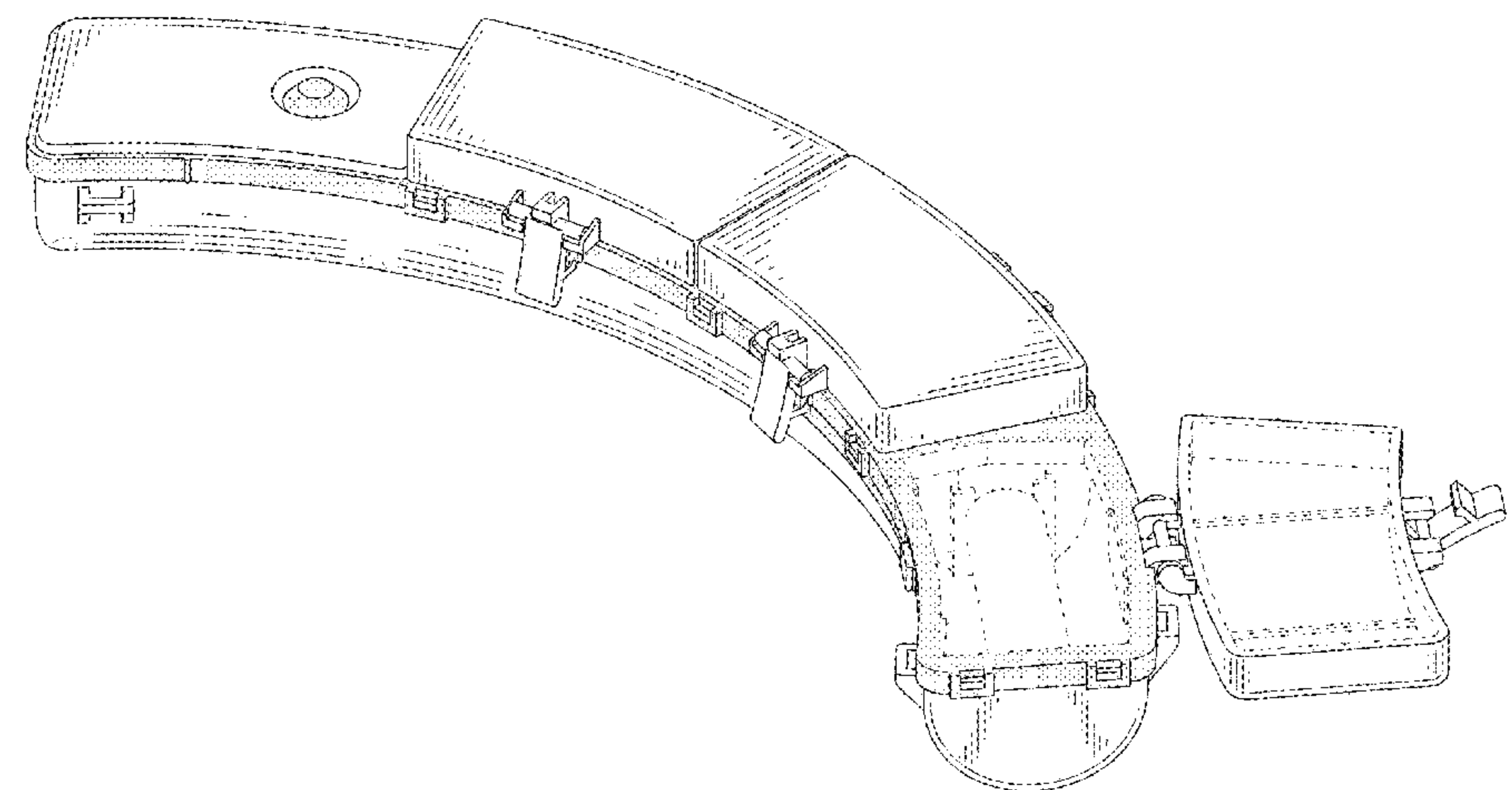

(56)

References Cited

U.S. PATENT DOCUMENTS

5,962,159	A *	10/1999	Satou	H01M 2/1055	429/1
6,197,446	B1 *	3/2001	Fukuda	H01M 2/0242	429/142
6,283,288	B1 *	9/2001	Rich	A01K 97/06	206/315.11
D534,068	S *	12/2006	Tanner	D9/424	
D535,874	S *	1/2007	Tanner	D9/422	
7,624,890	B2 *	12/2009	Noble	A61J 7/04	206/538
9,362,657	B1 *	6/2016	Yang	A47G 33/12	
D775,462	S *	1/2017	Noble	D3/203.3	
D777,104	S *	1/2017	Liu	D13/119	
9,762,987	B2 *	9/2017	Snyder	H04R 1/02	
D821,968	S *	7/2018	Zhao	D13/103	
D825,464	S *	8/2018	Xie	D13/119	
D831,331	S *	10/2018	Lee	D3/203.3	
D833,733	S *	11/2018	Chen	D3/203.3	
2001/0035416	A1 *	11/2001	Dodson	A47K 10/421	220/524
2003/0038053	A1 *	2/2003	Bramen	B65D 43/164	206/538
2004/0089581	A1 *	5/2004	Dienst	B65D 43/22	206/538
2005/0095501	A1 *	5/2005	Nishio	H01M 2/105	429/178
2007/0178368	A1 *	8/2007	Wu	H01M 2/1038	429/97
2007/0228047	A1 *	10/2007	Pehr	B65D 51/18	220/524
2009/0008395	A1 *	1/2009	Sattler	B01L 3/50853	220/507
2010/0323226	A1 *	12/2010	Kim	H01M 2/1066	429/7
2012/0121969	A1 *	5/2012	Takemura	B29C 45/0017	429/176
2013/0115482	A1 *	5/2013	Yi	H01M 2/1055	429/7
2013/0224525	A1 *	8/2013	Baek	H01M 2/105	429/7
2015/0093622	A1 *	4/2015	Lee	H01M 2/105	429/99
2015/0267902	A1 *	9/2015	Zhang	F21L 4/04	362/188
2016/0276639	A1 *	9/2016	Tian	A63C 17/26	
2017/0244073	A1 *	8/2017	Yusa	H01M 2/10	
2018/0013107	A1 *	1/2018	Lam	H01M 10/425	

* cited by examiner

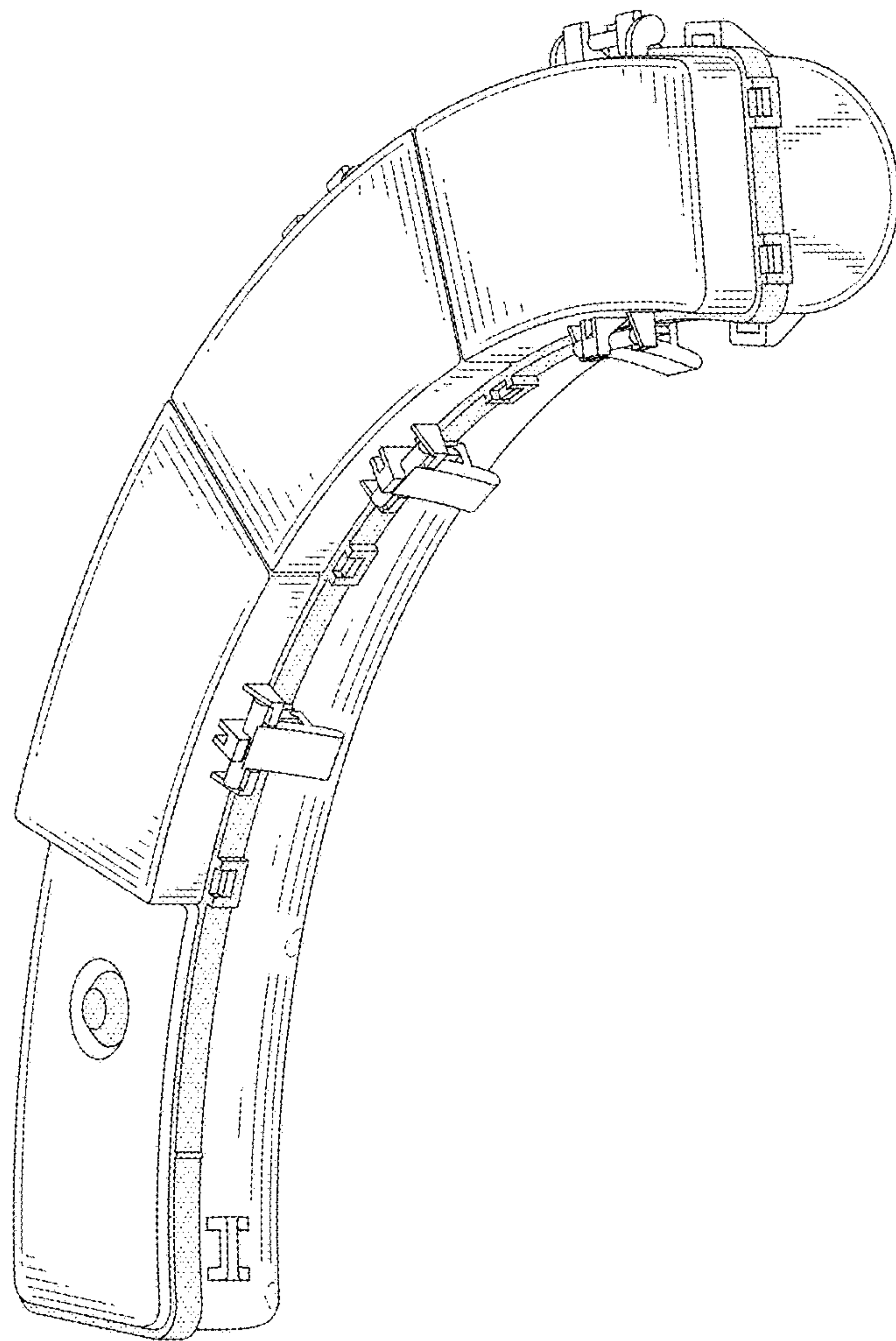

FIG.1

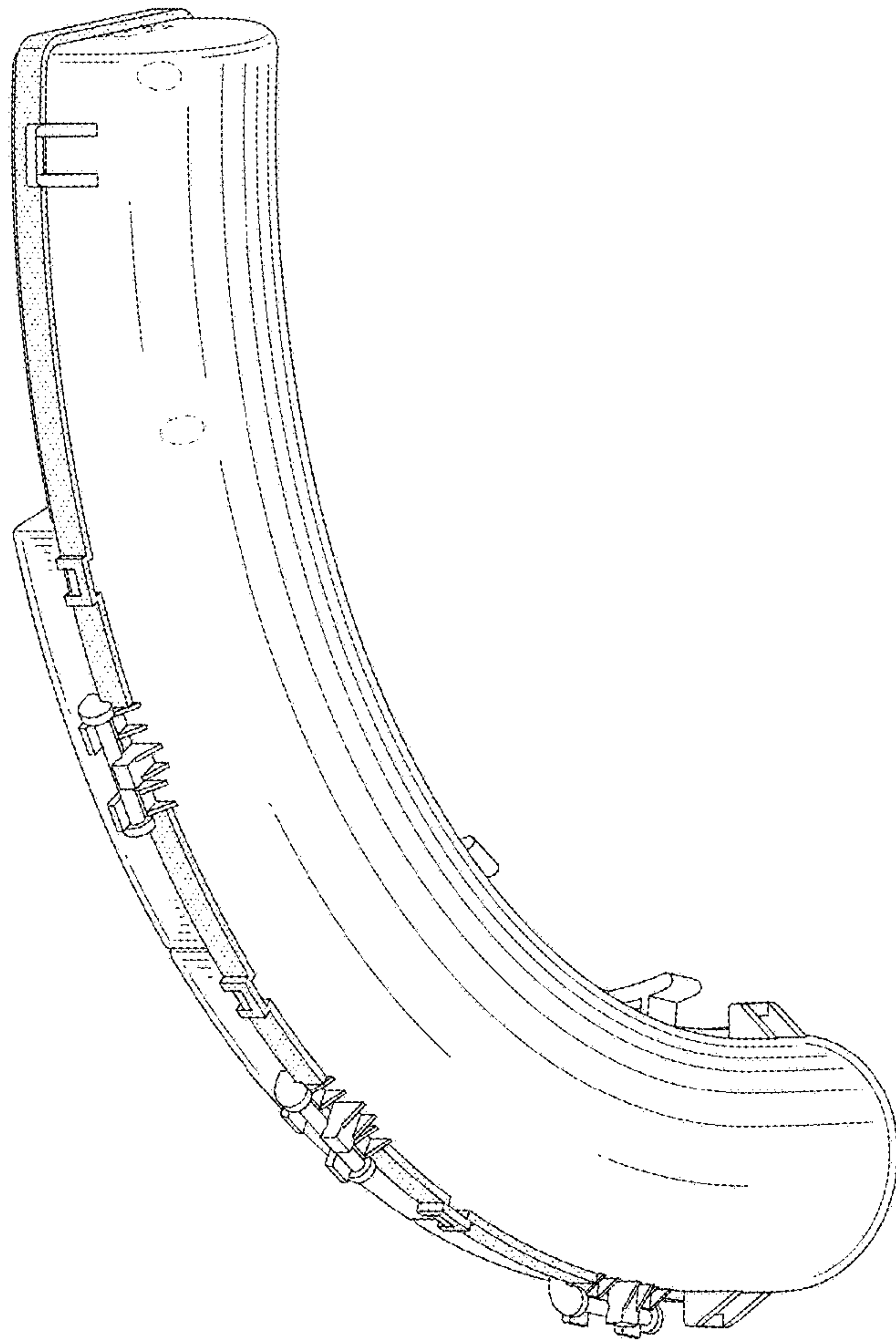

FIG.2

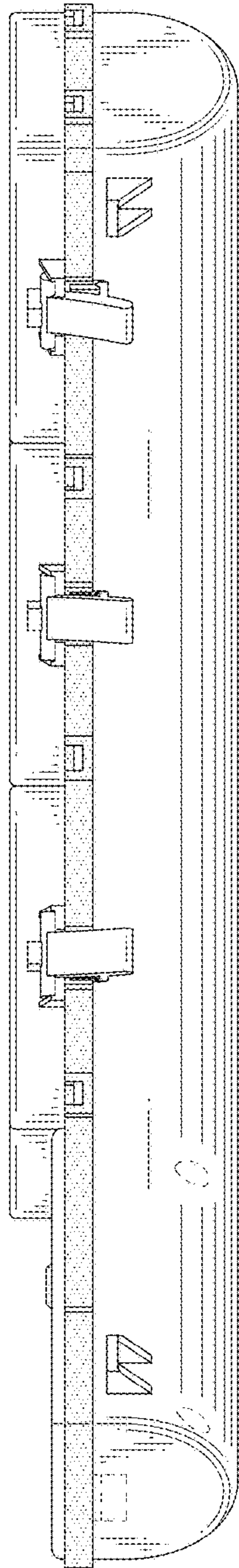

FIG.3

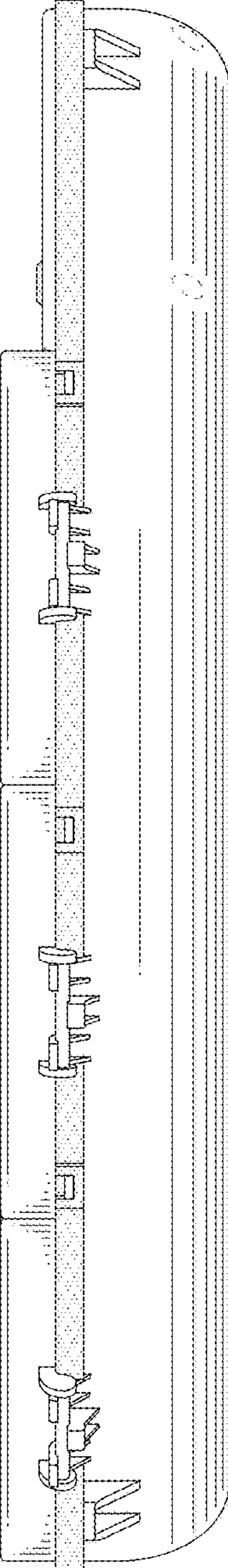

FIG.4

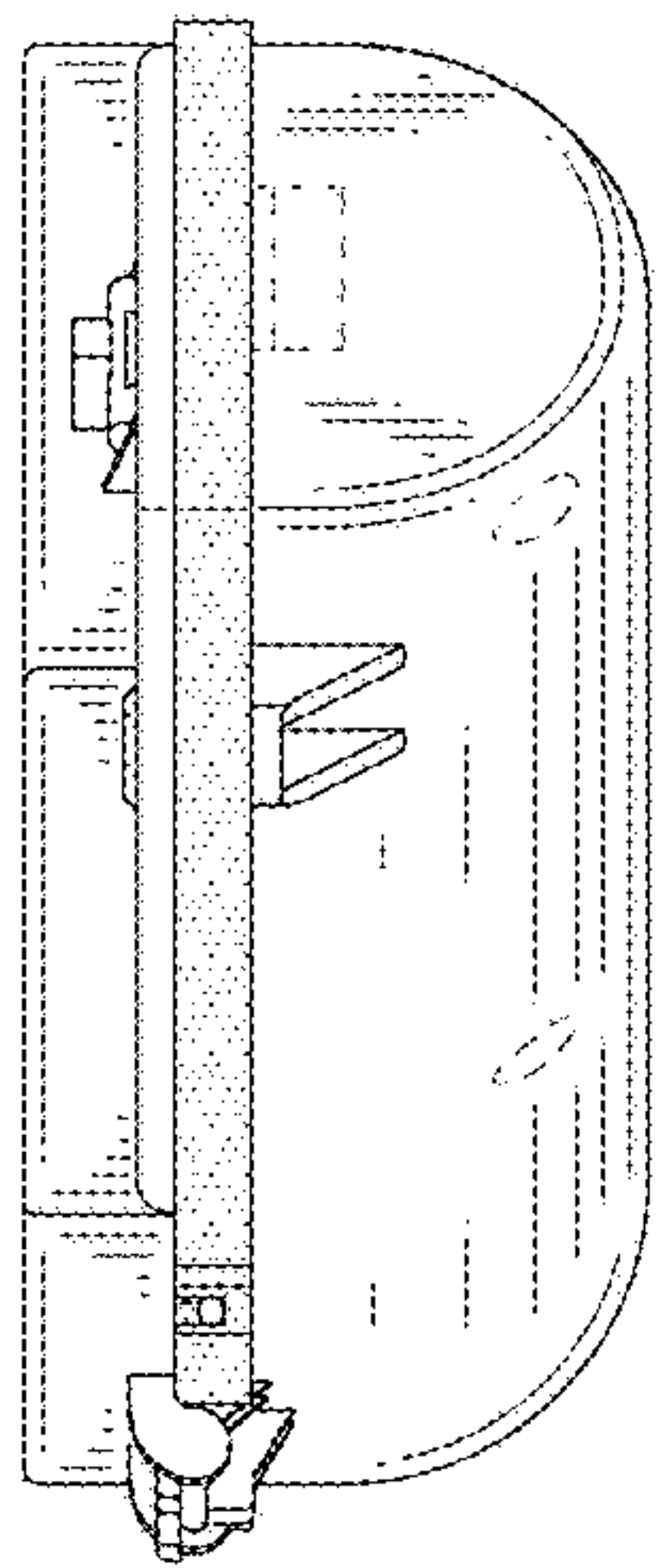

FIG.5

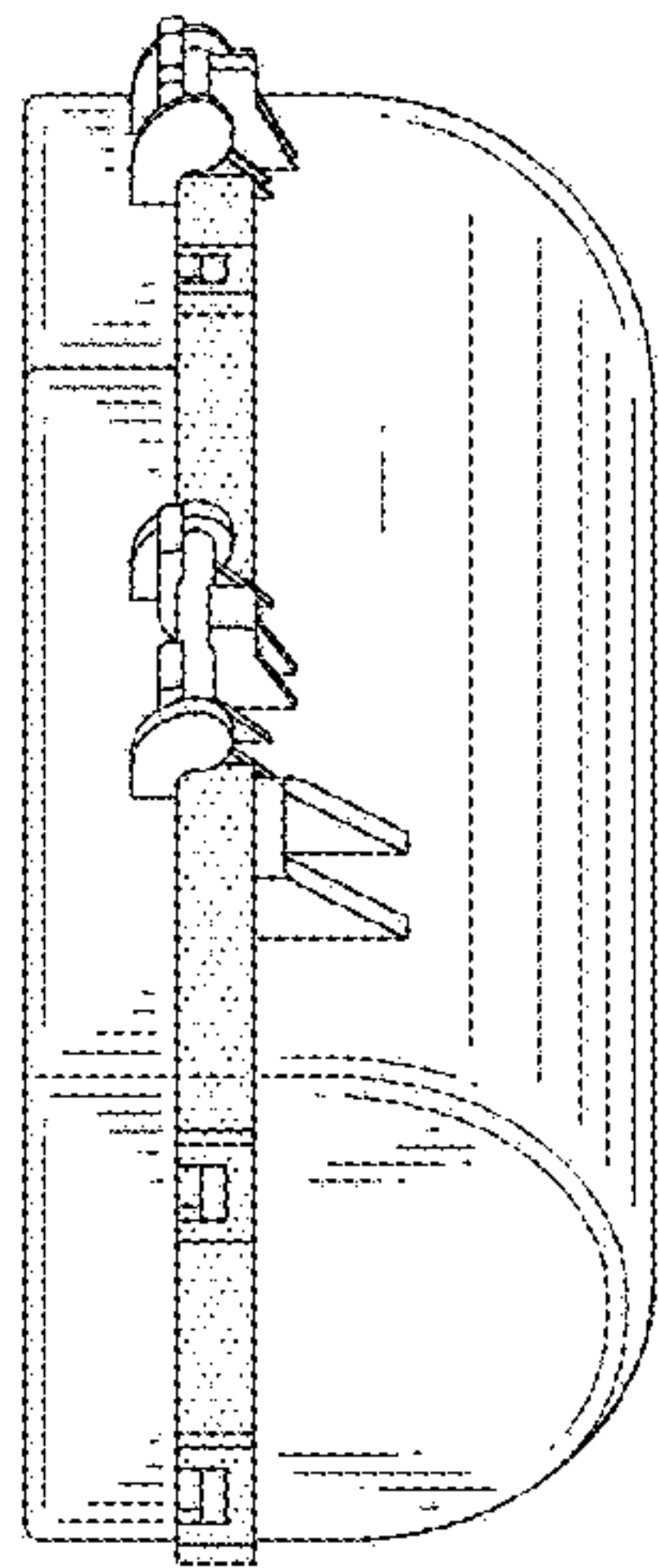

FIG.6

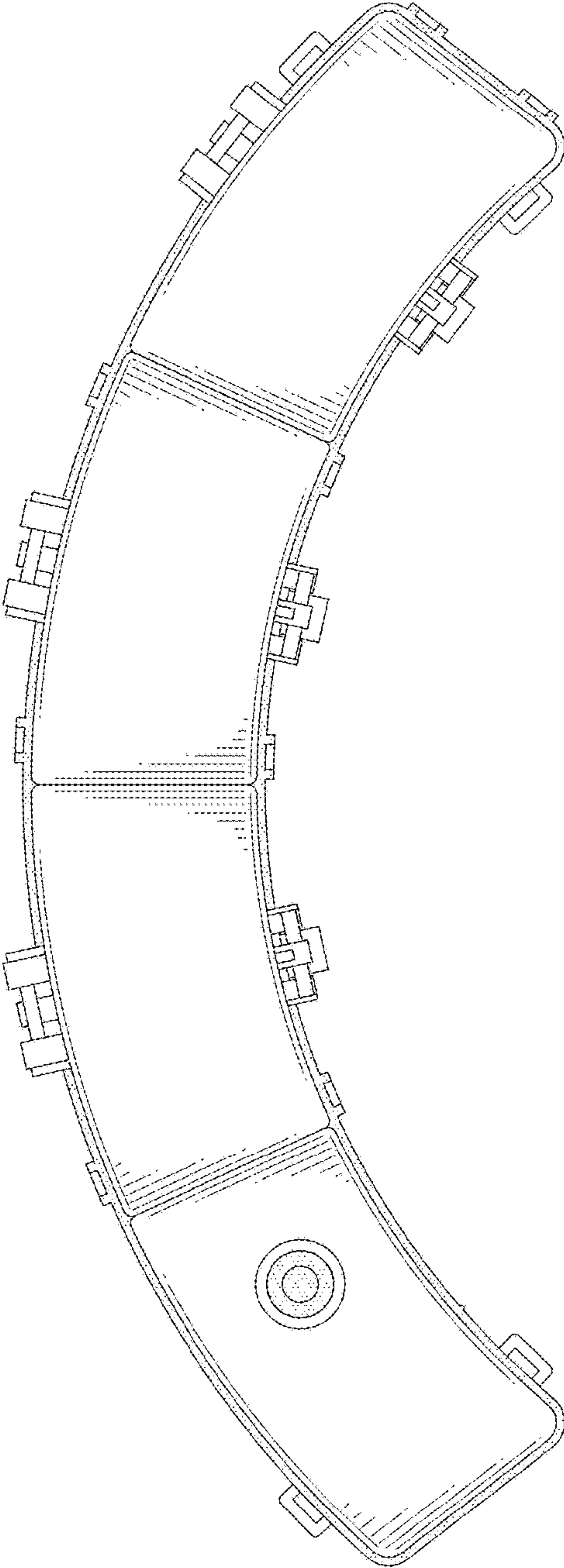

FIG.7

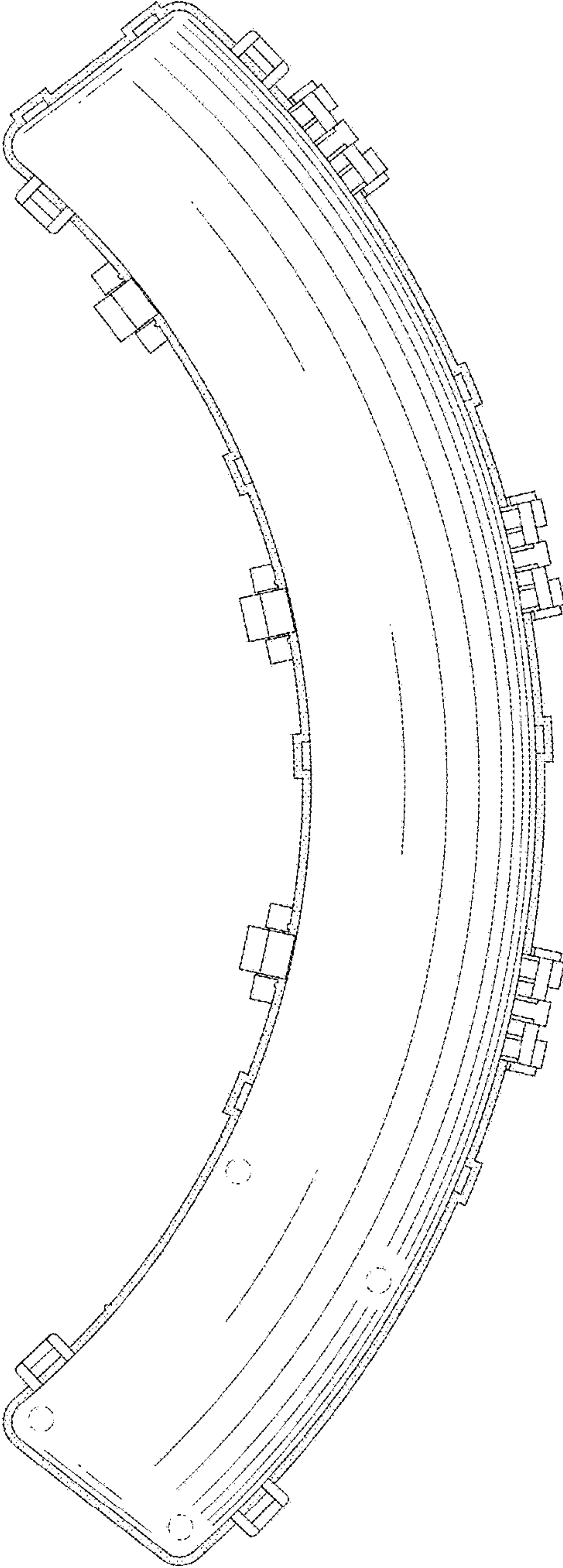

FIG.8

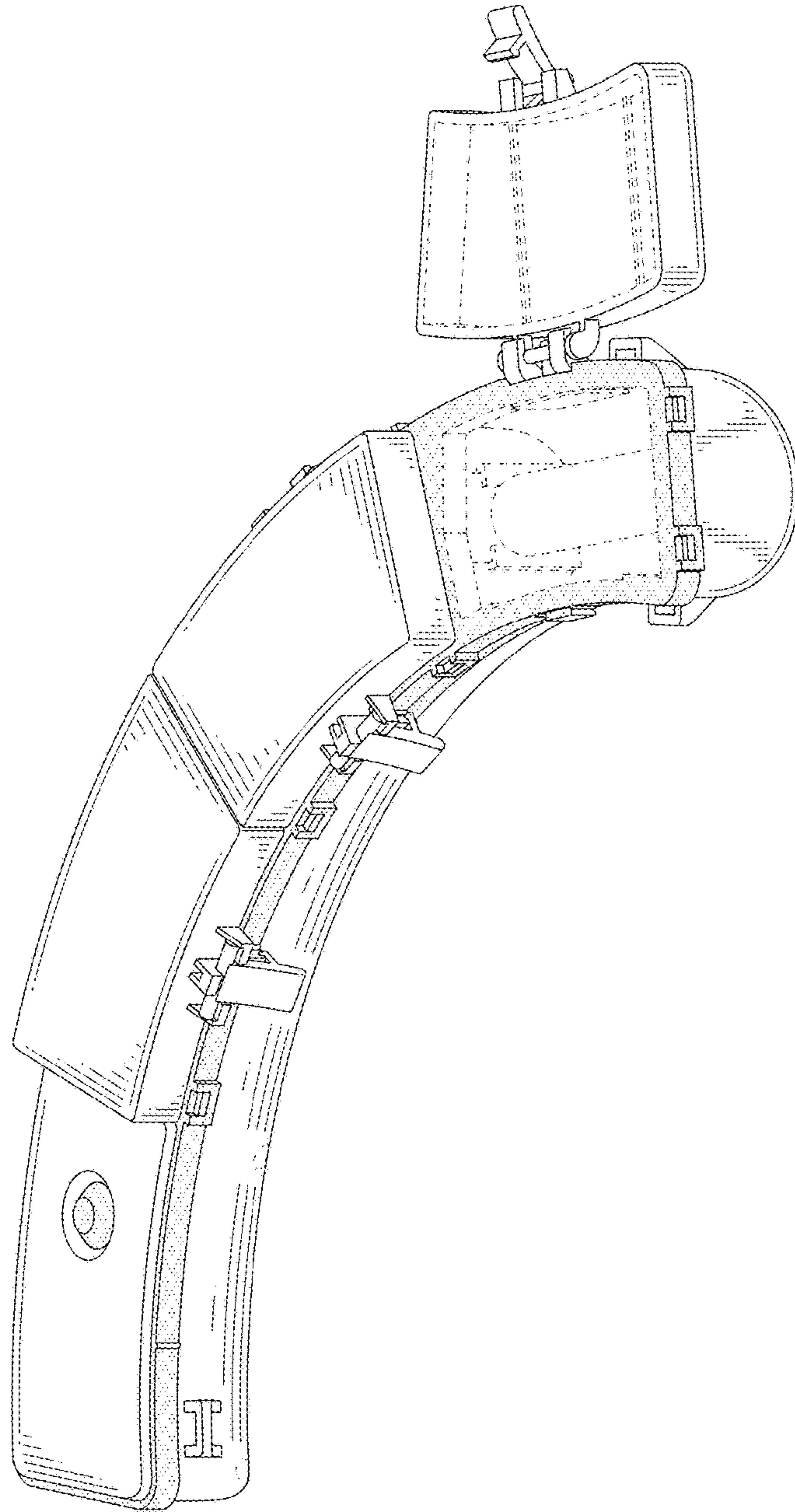

FIG.9