



US00D871258S

(12) **United States Design Patent**  
**Cotter**

(10) **Patent No.:** **US D871,258 S**

(45) **Date of Patent:** **\*\* \*Dec. 31, 2019**

(54) **HYBRID PEDAL AND ELECTRIC POWERED VEHICLE**

(71) Applicant: **Robert M. Cotter**, Raleigh, NC (US)

(72) Inventor: **Robert M. Cotter**, Raleigh, NC (US)

(73) Assignee: **ORGANIC TRANSIT, INC.**, Durham, NC (US)

(\*) Notice: This patent is subject to a terminal disclaimer.

(\*\*) Term: **14 Years**

(21) Appl. No.: **29/447,202**

(22) Filed: **Mar. 1, 2013**

(51) **LOC (12) Cl.** ..... **12-08**

(52) **U.S. Cl.**  
USPC ..... **D12/85**

(58) **Field of Classification Search**  
USPC ..... D12/85, 86, 107; D21/424, 433, 434  
CPC ..... B62D 21/11; B62D 29/043; B62D 31/00;  
B62D 49/00; B62D 61/065; B62L 3/00;  
B62K 3/005; B62K 5/01; B62K 5/08;  
B62K 5/027  
See application file for complete search history.

(56) **References Cited**

**U.S. PATENT DOCUMENTS**

D203,665 S \* 2/1966 Cherry et al. .... D12/85  
D219,650 S \* 1/1971 Balch ..... D12/85

D268,402 S \* 3/1983 Riley ..... D12/85  
D283,113 S \* 3/1986 Stollery ..... D12/85  
D329,211 S \* 9/1992 Malewicki ..... D12/85  
D407,348 S \* 3/1999 Riley ..... D12/85  
6,015,022 A \* 1/2000 Thuliez ..... B62D 21/04  
180/210  
D547,701 S \* 7/2007 Vey ..... D12/110  
D626,032 S \* 10/2010 Starr ..... D12/85  
D678,124 S \* 3/2013 Canni ..... D12/85  
D690,622 S \* 10/2013 Bruce ..... D12/110  
D695,644 S \* 12/2013 Timonen ..... D12/85  
2014/0019006 A1 \* 1/2014 Bruce ..... B62D 5/0457  
701/41

\* cited by examiner

*Primary Examiner* — Darlington Ly

(74) *Attorney, Agent, or Firm* — NK Patent Law

(57) **CLAIM**

The ornamental design for a hybrid pedal and electric powered vehicle, as shown and described.

**DESCRIPTION**

FIG. 1 is a front and left side perspective view of a hybrid pedal and electric powered vehicle showing my new design; FIG. 2 is a rear and left side perspective view thereof; FIG. 3 is a front elevation view thereof; FIG. 4 is a rear elevation view thereof; FIG. 5 is a left side elevation view thereof; and, FIG. 6 is a top plan view thereof.

The broken lines in the drawings illustrate portions of the hybrid pedal and electric powered vehicle that form no part of the claimed design.

**1 Claim, 3 Drawing Sheets**

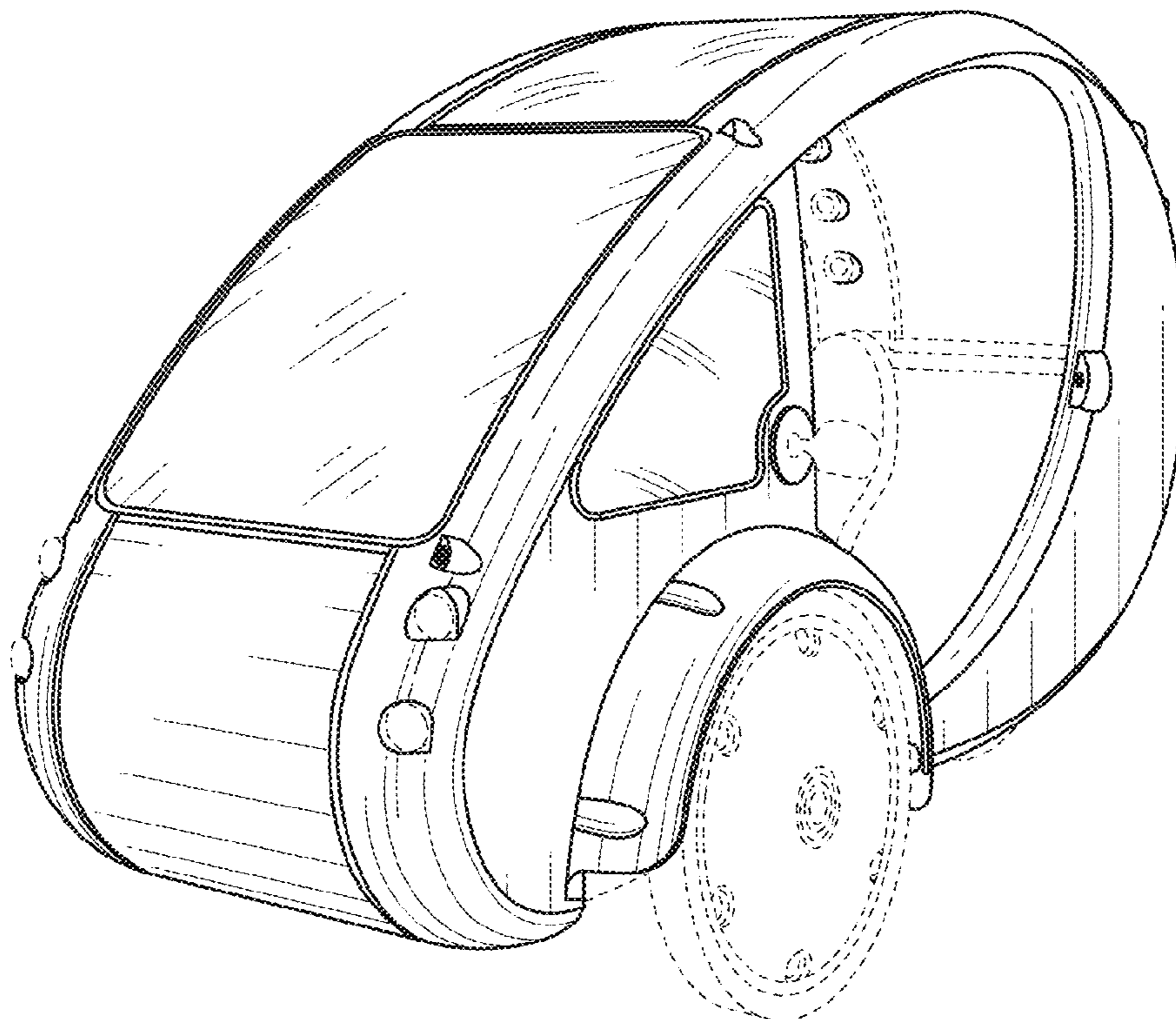

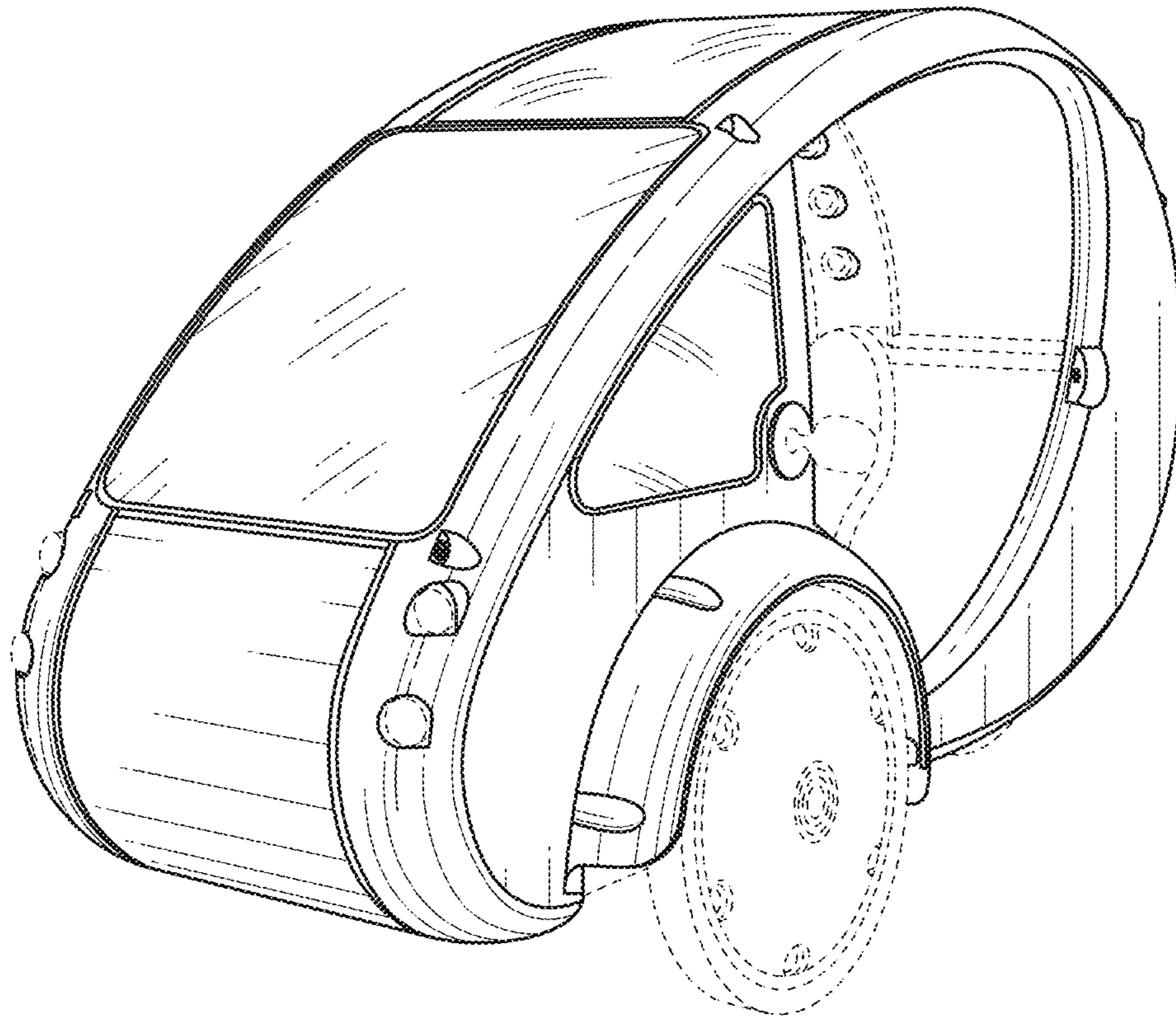

FIG. 1

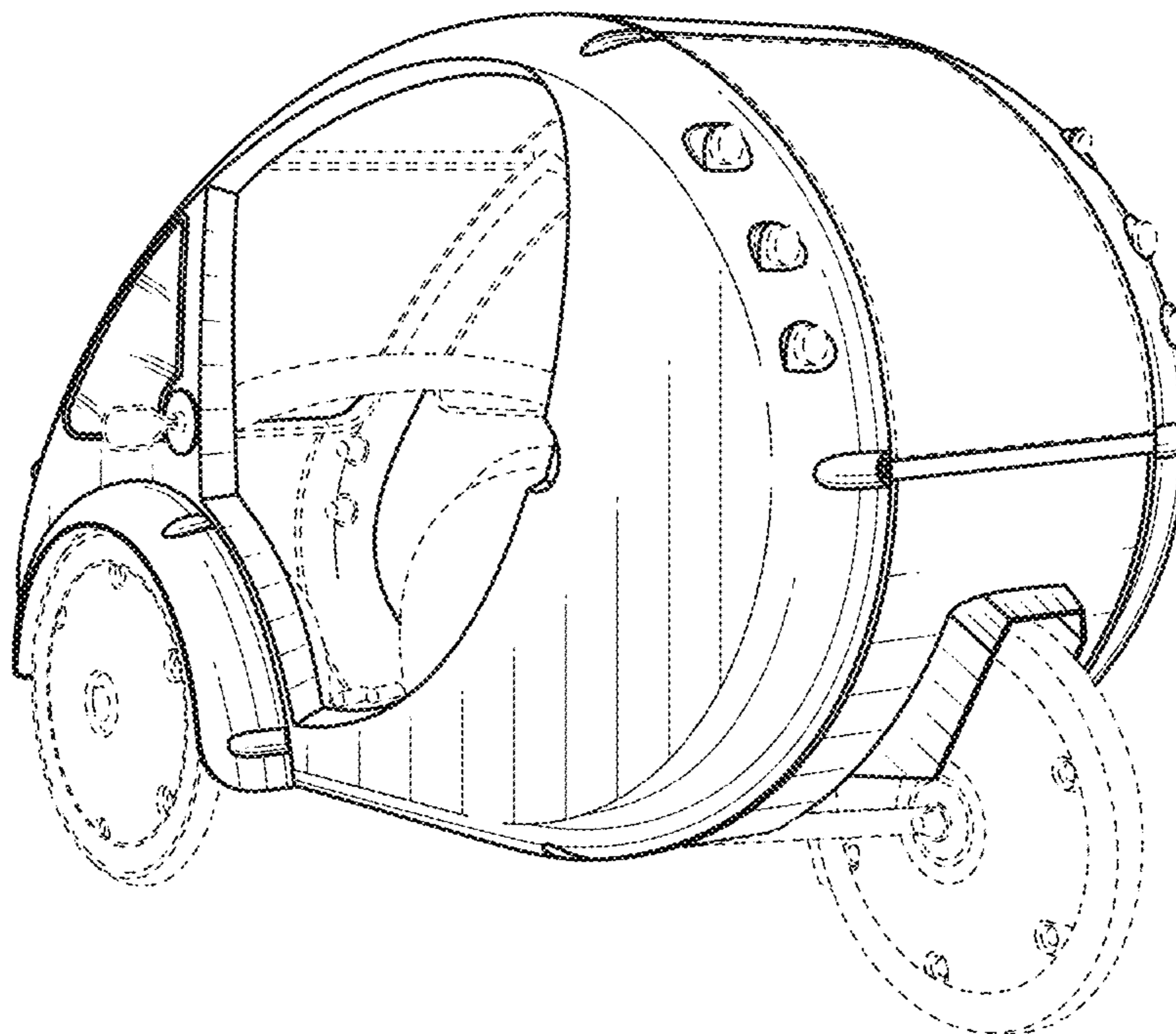

FIG. 2

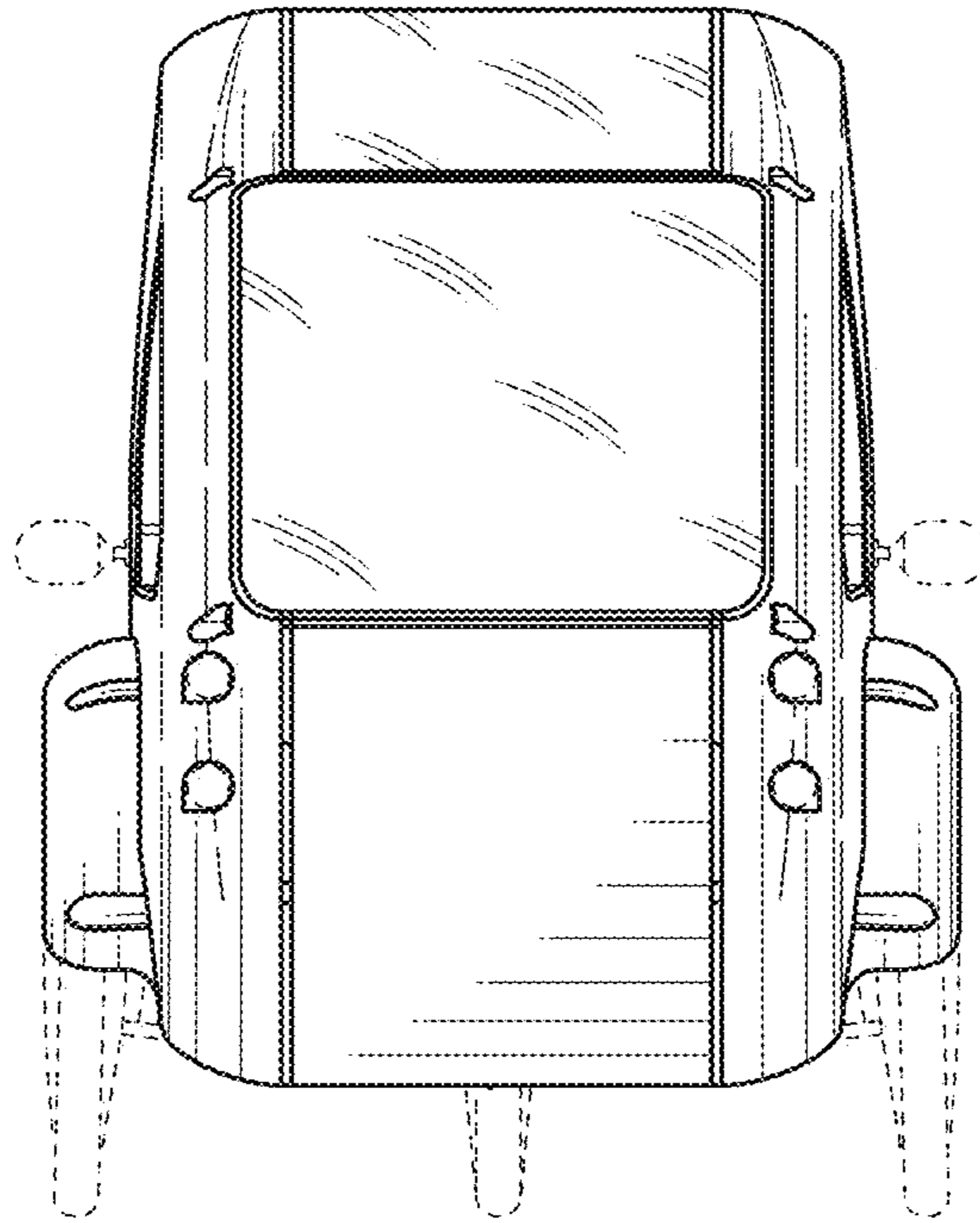

FIG. 3

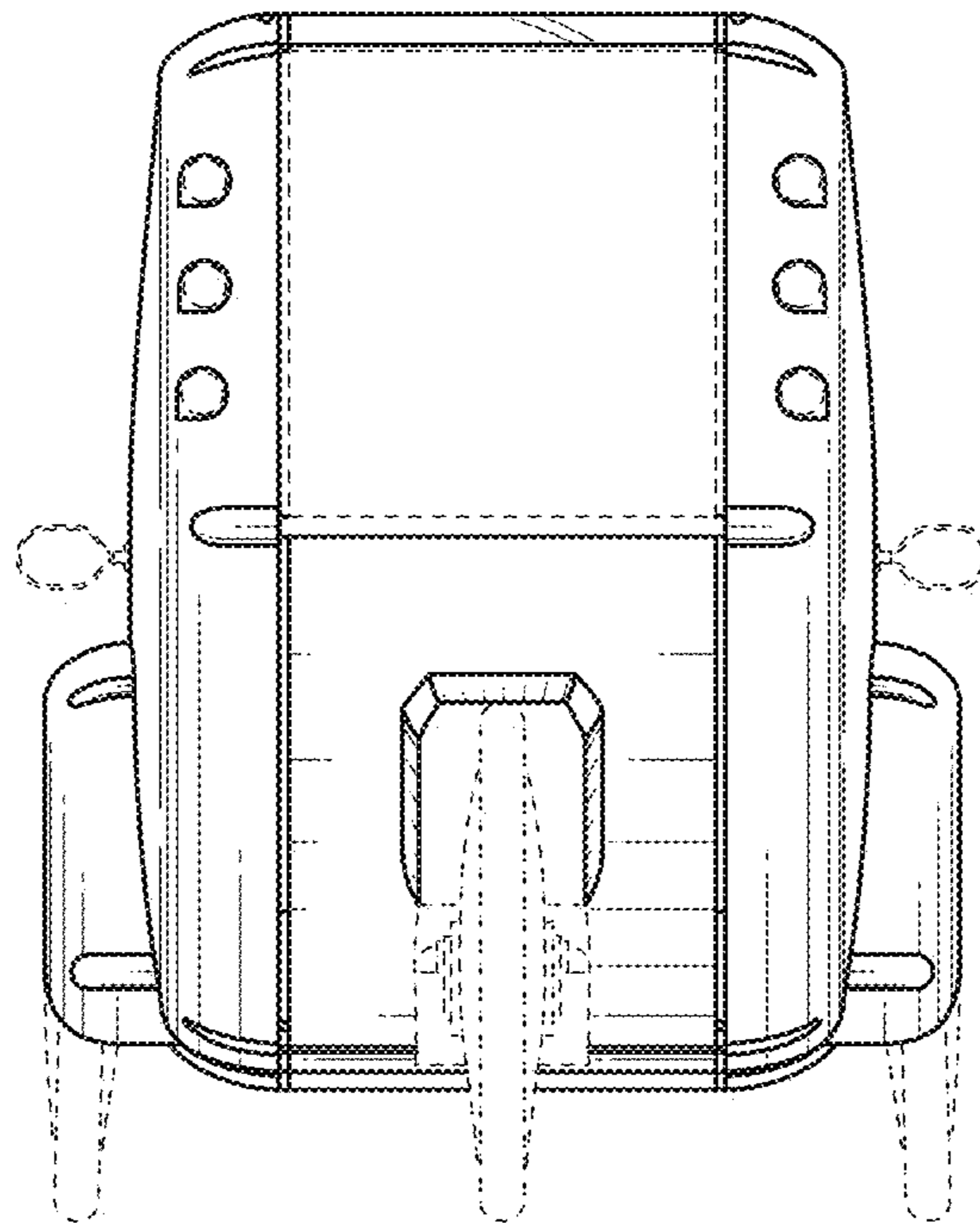

FIG. 4

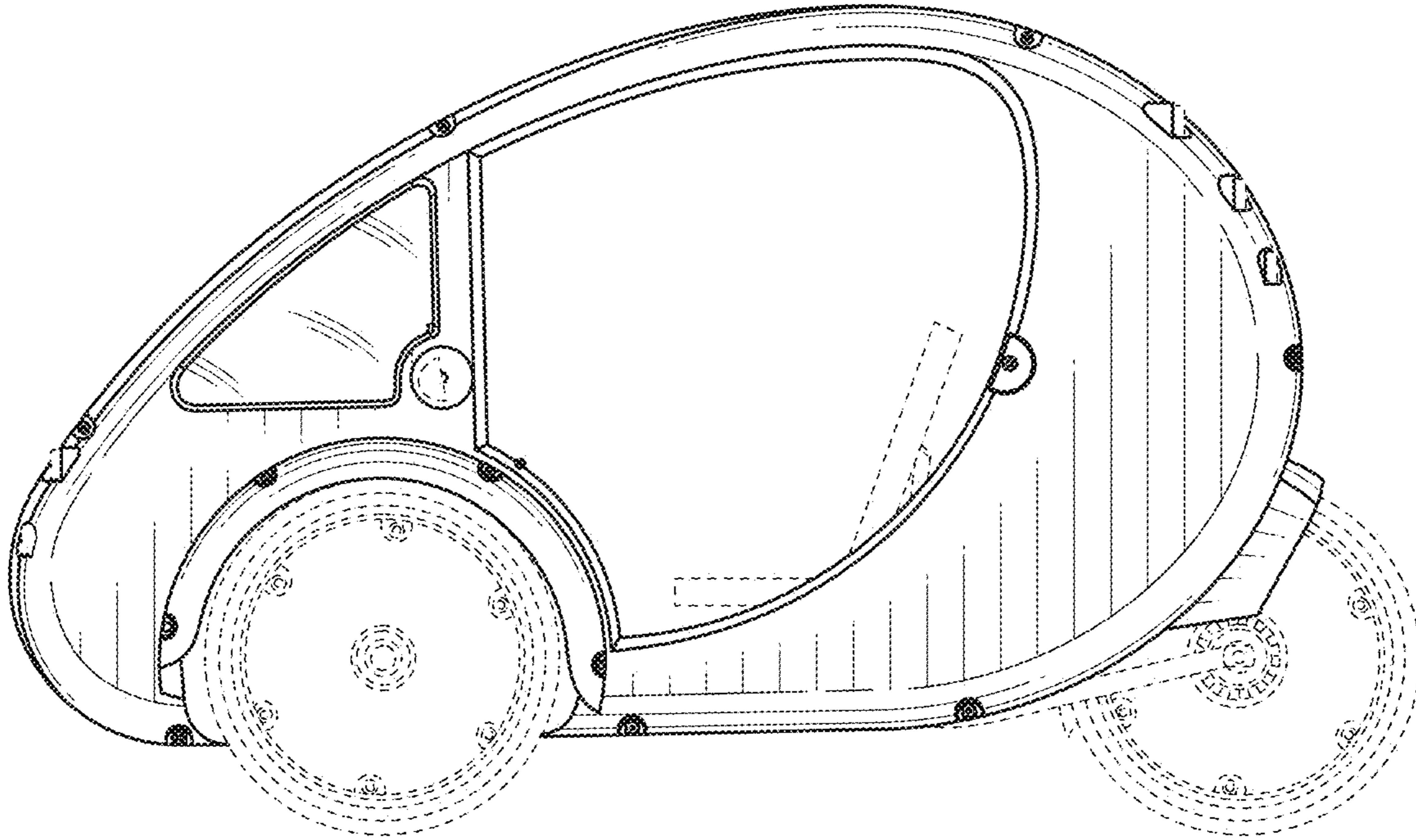

FIG. 5

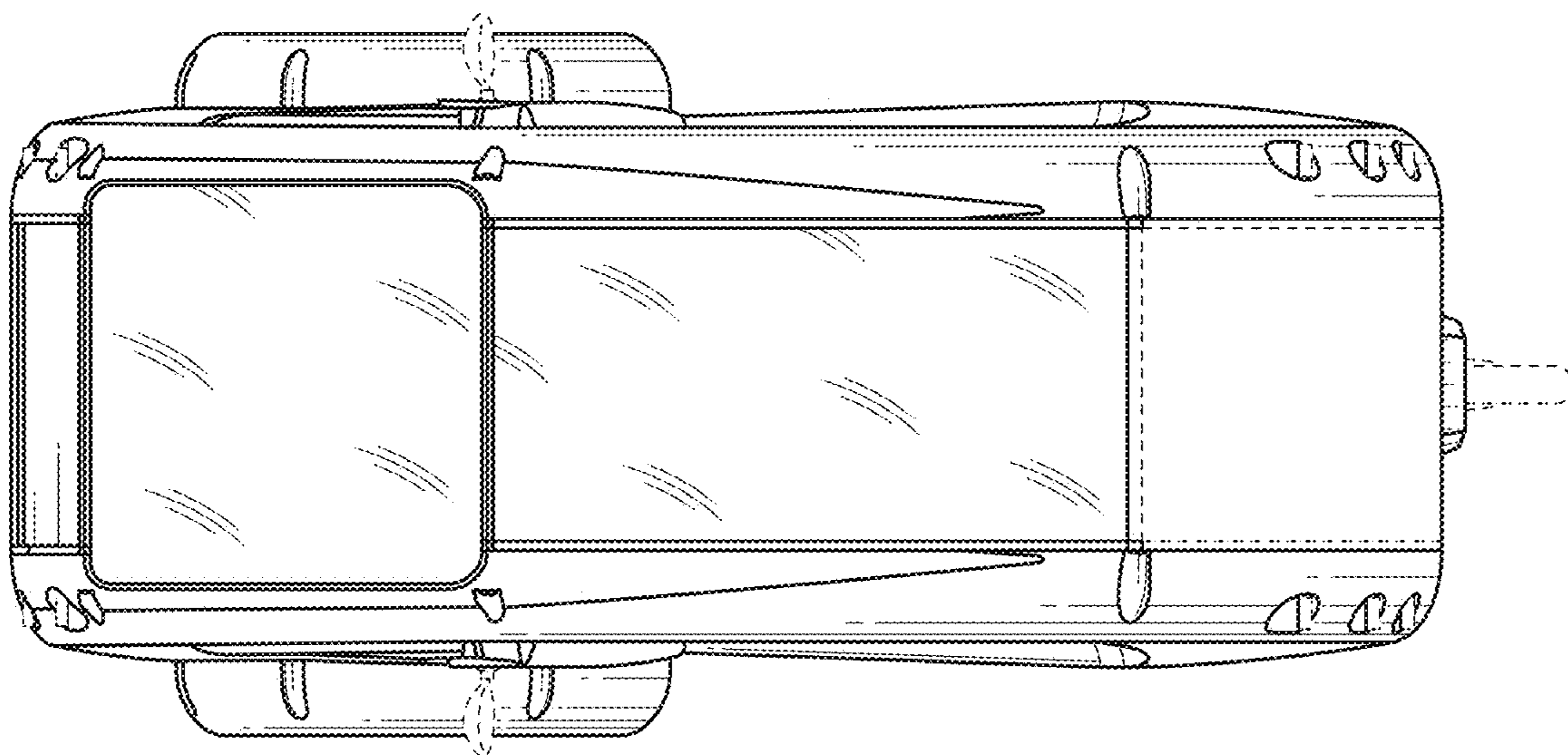

FIG. 6