



US00D871014S

(12) **United States Design Patent** (10) **Patent No.:** **US D871,014 S**
Robinson (45) **Date of Patent:** **** Dec. 24, 2019**

(54) **TIRE HANDLING CART**
(71) Applicant: **Kevin A Robinson**, Brighton, CO (US)
(72) Inventor: **Kevin A Robinson**, Brighton, CO (US)
(**) Term: **15 Years**
(21) Appl. No.: **29/625,506**
(22) Filed: **Nov. 9, 2017**
(51) **LOC (12) Cl.** **12-05**
(52) **U.S. Cl.**
USPC **D34/28**
(58) **Field of Classification Search**
USPC D34/28, 31, 39; D12/202
CPC B60B 29/00; B60B 29/001; B60B 29/002;
B60B 29/007; B60B 30/04; B60B 30/10;
B62D 65/12
See application file for complete search history.

(56) **References Cited**
U.S. PATENT DOCUMENTS
4,690,605 A * 9/1987 Coccoaro B60B 29/002
254/119
D327,762 S * 7/1992 Silbersky D34/28
D379,017 S * 4/1997 Chapman D34/28
5,895,030 A * 4/1999 Mohun B60B 29/002
254/7 R
D602,670 S * 10/2009 Laursen B60B 29/002
D34/23
7,611,126 B2 * 11/2009 Vesa B66F 9/18
254/2 B

D613,022 S * 3/2010 Laursen B60B 30/02
D34/23
10,035,688 B1 * 7/2018 Robinson B60B 30/02
2012/0057954 A1 * 3/2012 Bardin B60B 30/02
414/427
* cited by examiner
Primary Examiner — Sheryl Lane
Assistant Examiner — Calvin E Vansant
(74) *Attorney, Agent, or Firm* — Quickpatents, LLC;
Kevin Prince

(57) **CLAIM**
I claim the ornamental design for a tire handling cart, as shown and described.

DESCRIPTION
FIG. 1 is a perspective view of a tire rotation assistance cart, showing my new design in a base-raised configuration; FIG. 2 is a front elevational view of FIG. 1; FIG. 3 is a rear elevational view of FIG. 1; FIG. 4 is a left-side elevational view of FIG. 1; FIG. 5 is a right-side elevational view of FIG. 1; FIG. 6 is a top plan view of FIG. 1; FIG. 7 is a bottom plan view of FIG. 1; FIG. 8 is a perspective view thereof, illustrated in a base-lowered configuration; FIG. 9 is a front elevational view of FIG. 8; FIG. 10 is a rear elevational view of FIG. 8; FIG. 11 is a left-side elevational view of FIG. 8; FIG. 12 is a right-side elevational view of FIG. 8; FIG. 13 is a top plan view of FIG. 8; and, FIG. 14 is a bottom plan view of FIG. 8. The broken lines showing a tire in FIGS. 1 and 8 depict environmental matter and form no part of the claimed design.

1 Claim, 12 Drawing Sheets

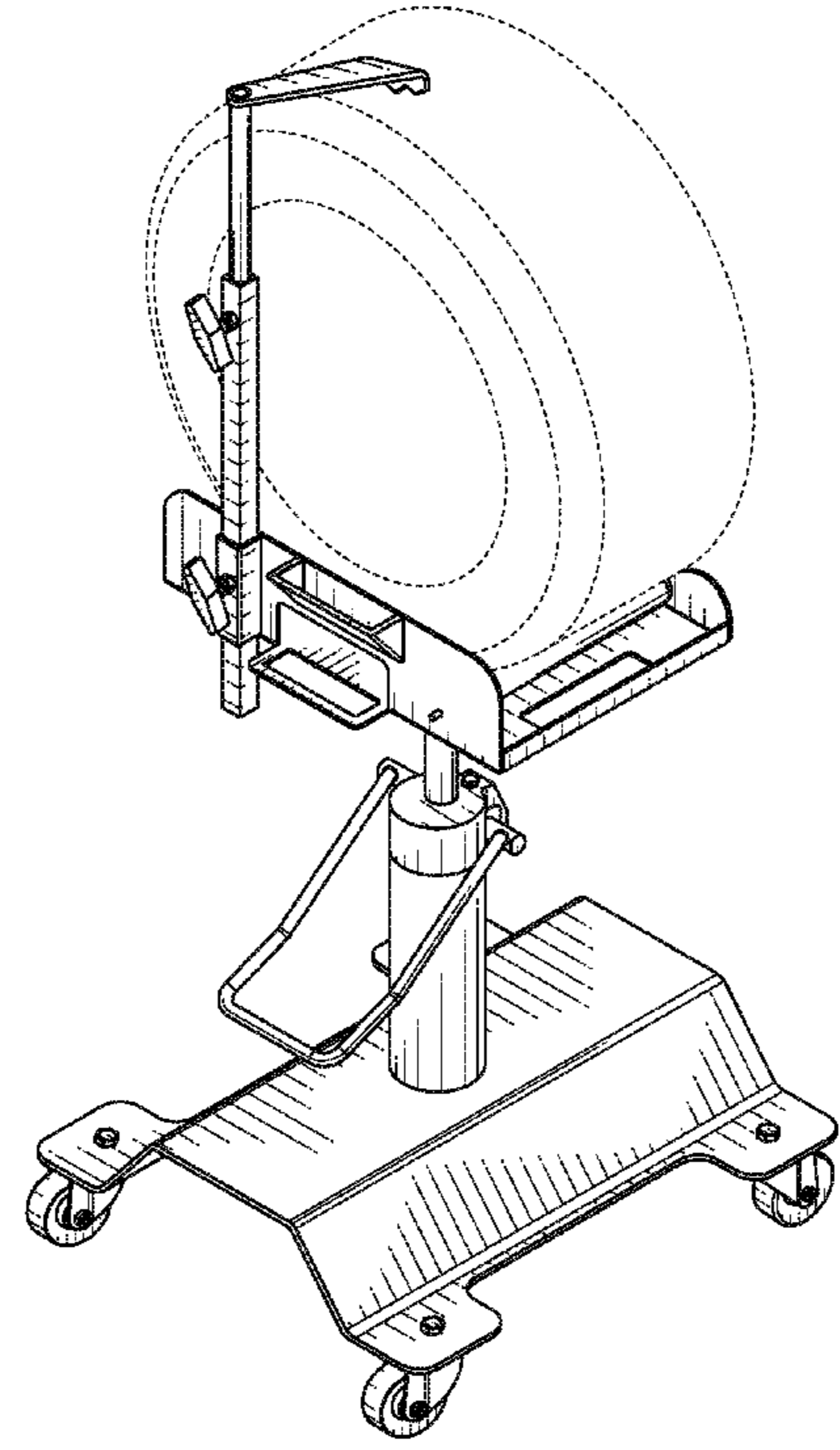

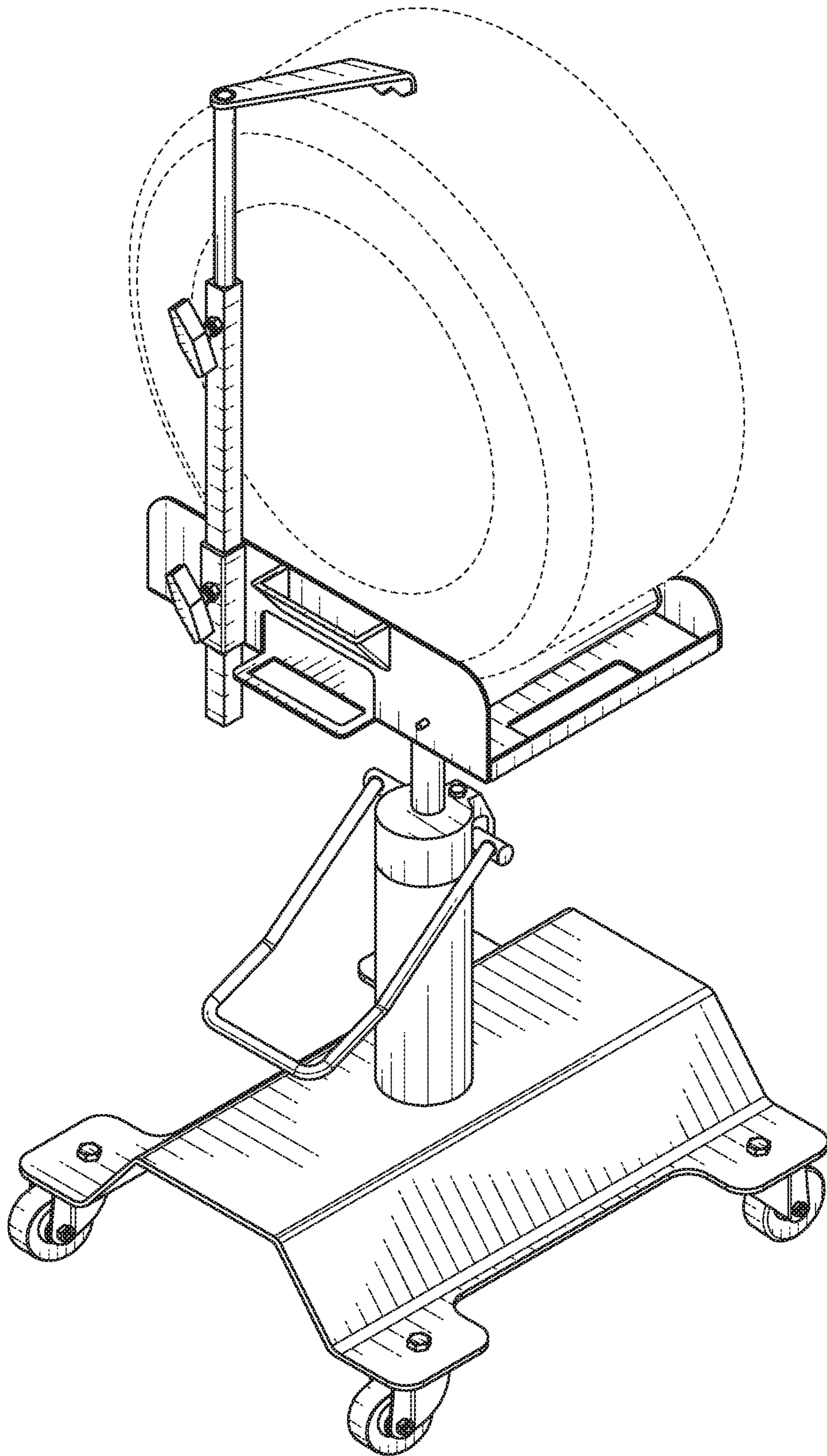

FIG. 1

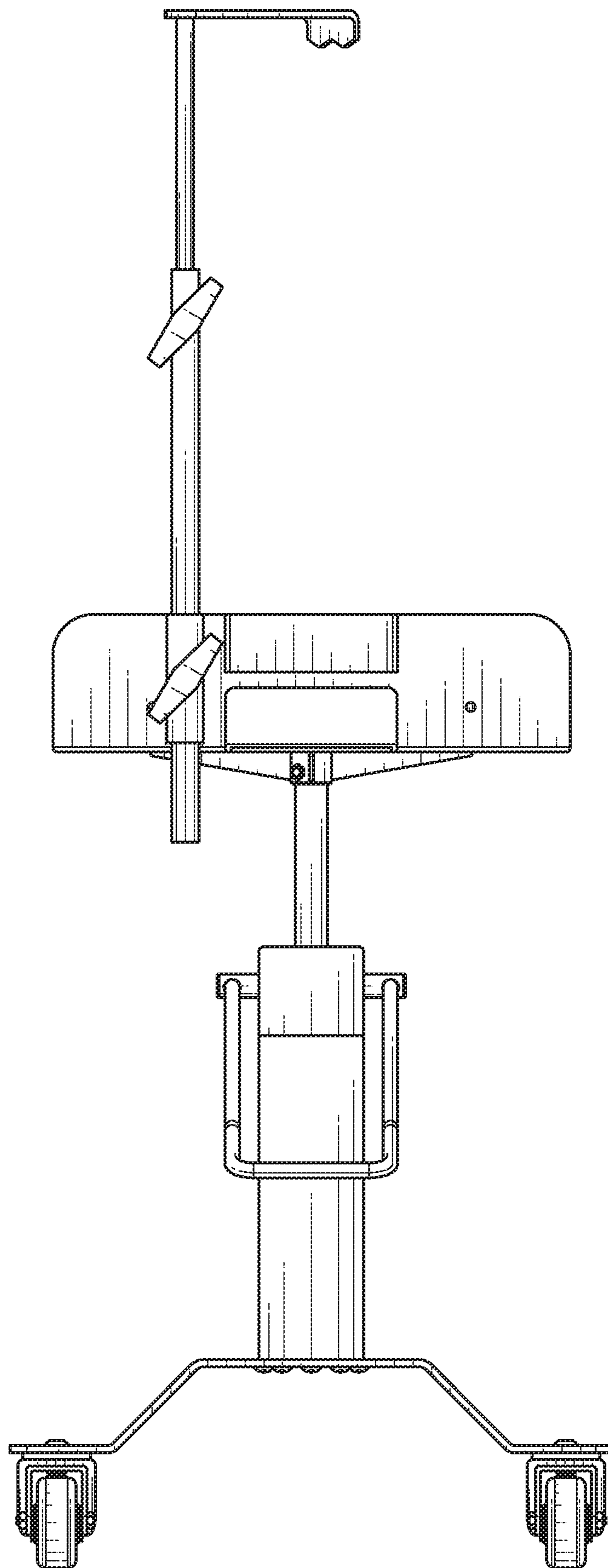

FIG. 2

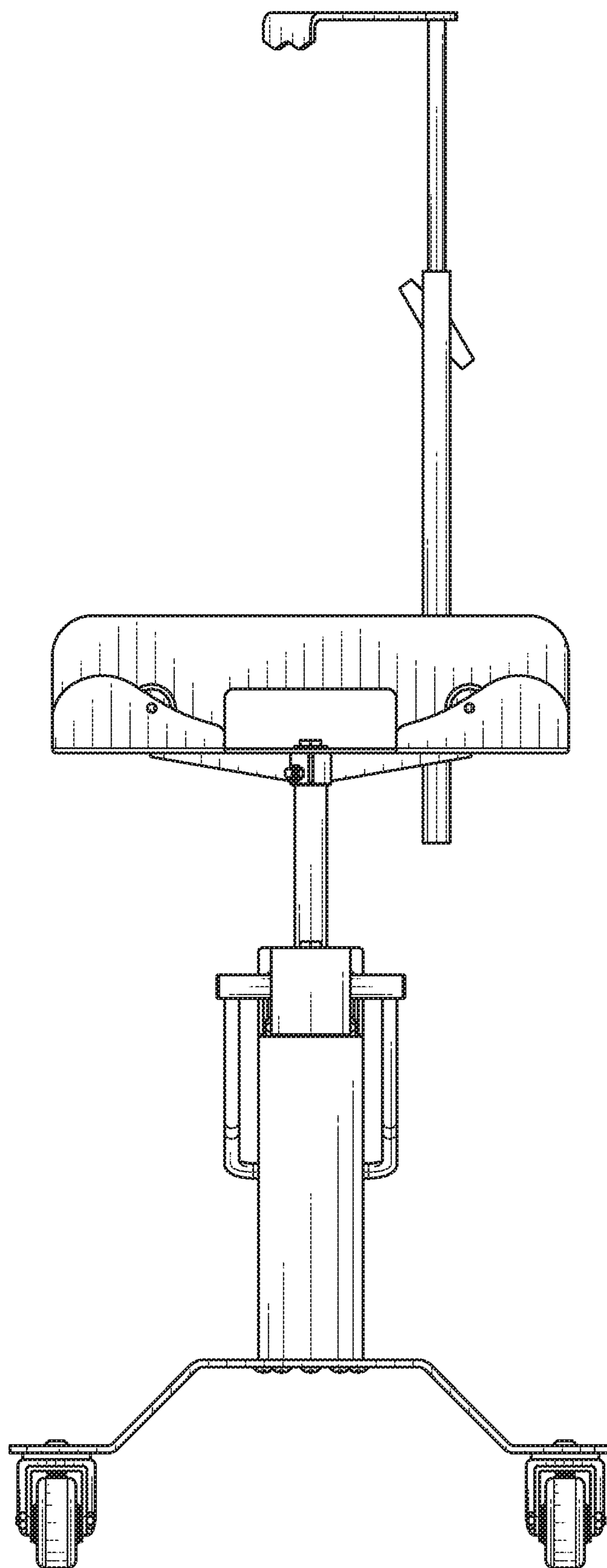

FIG. 3

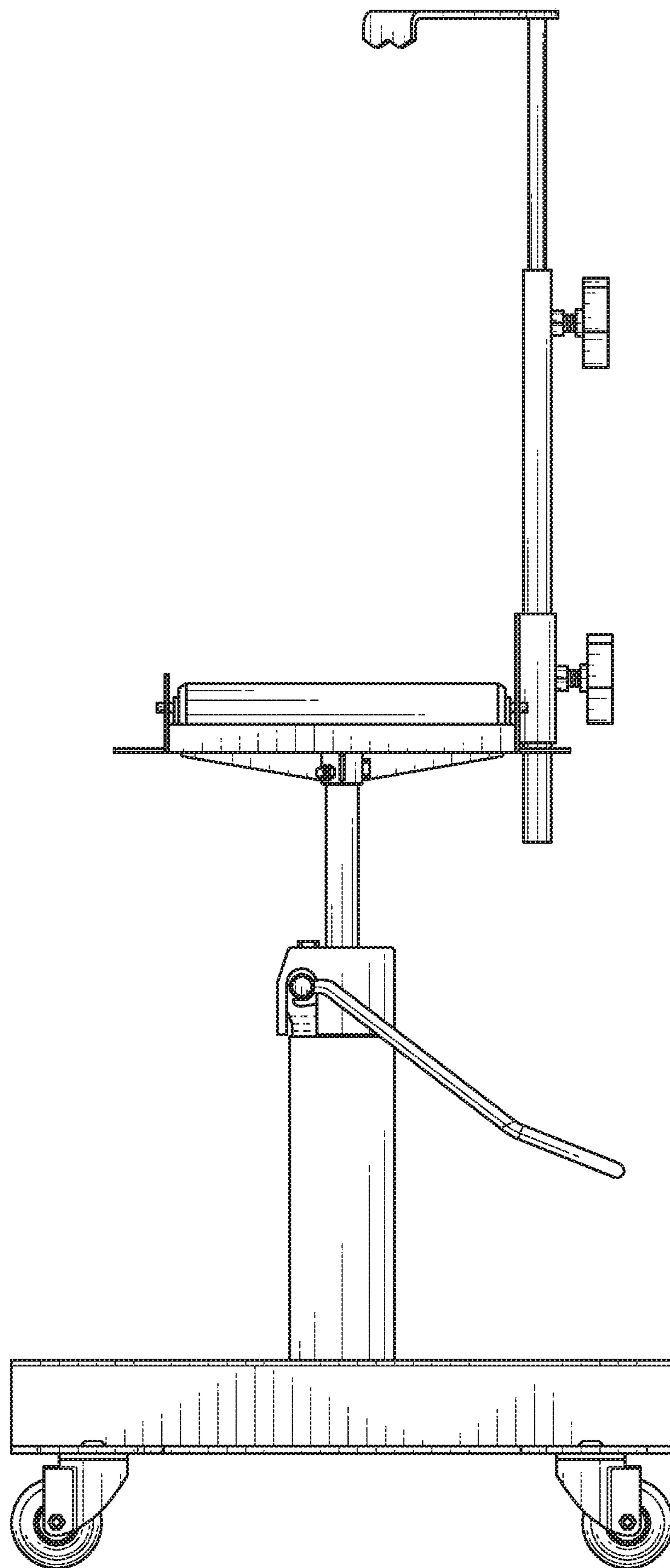

FIG. 4

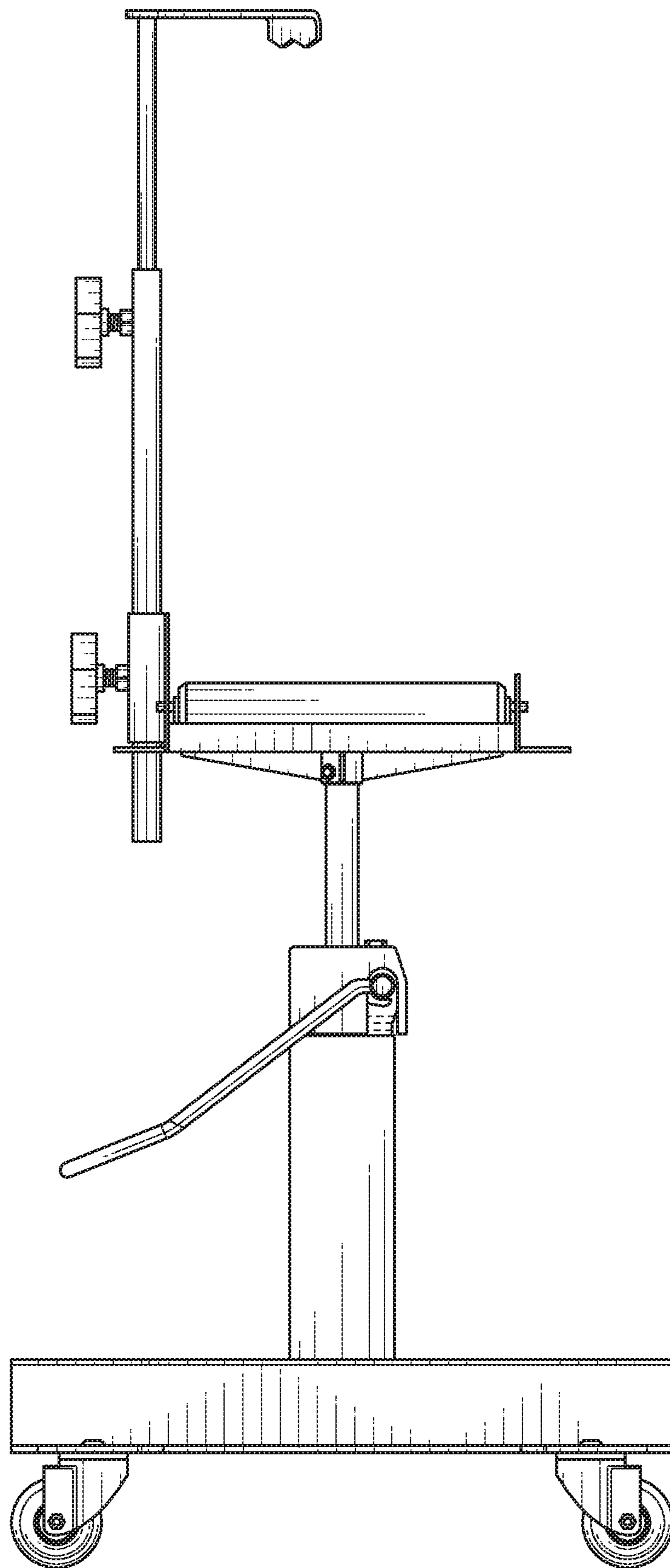

FIG. 5

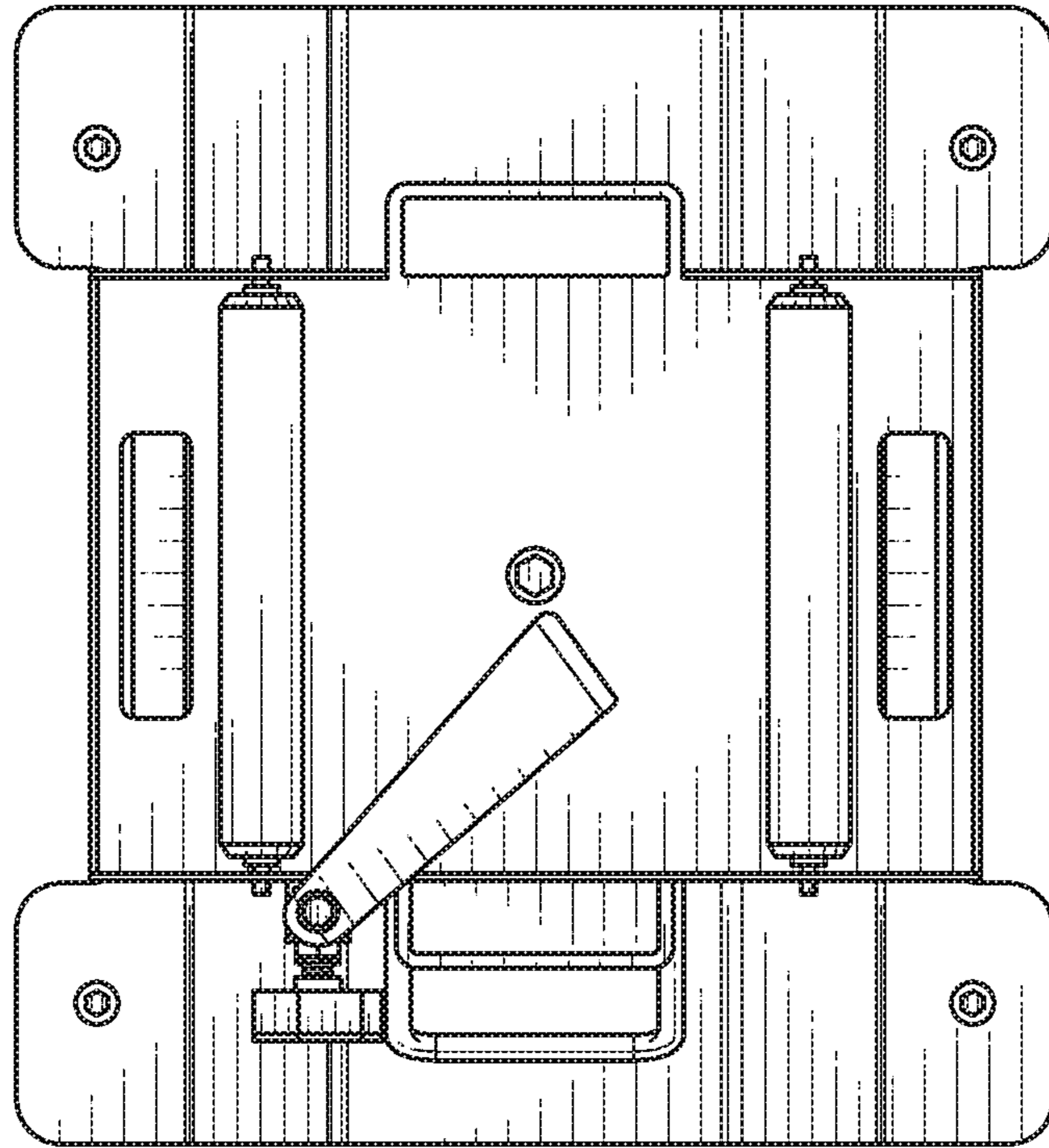

FIG. 6

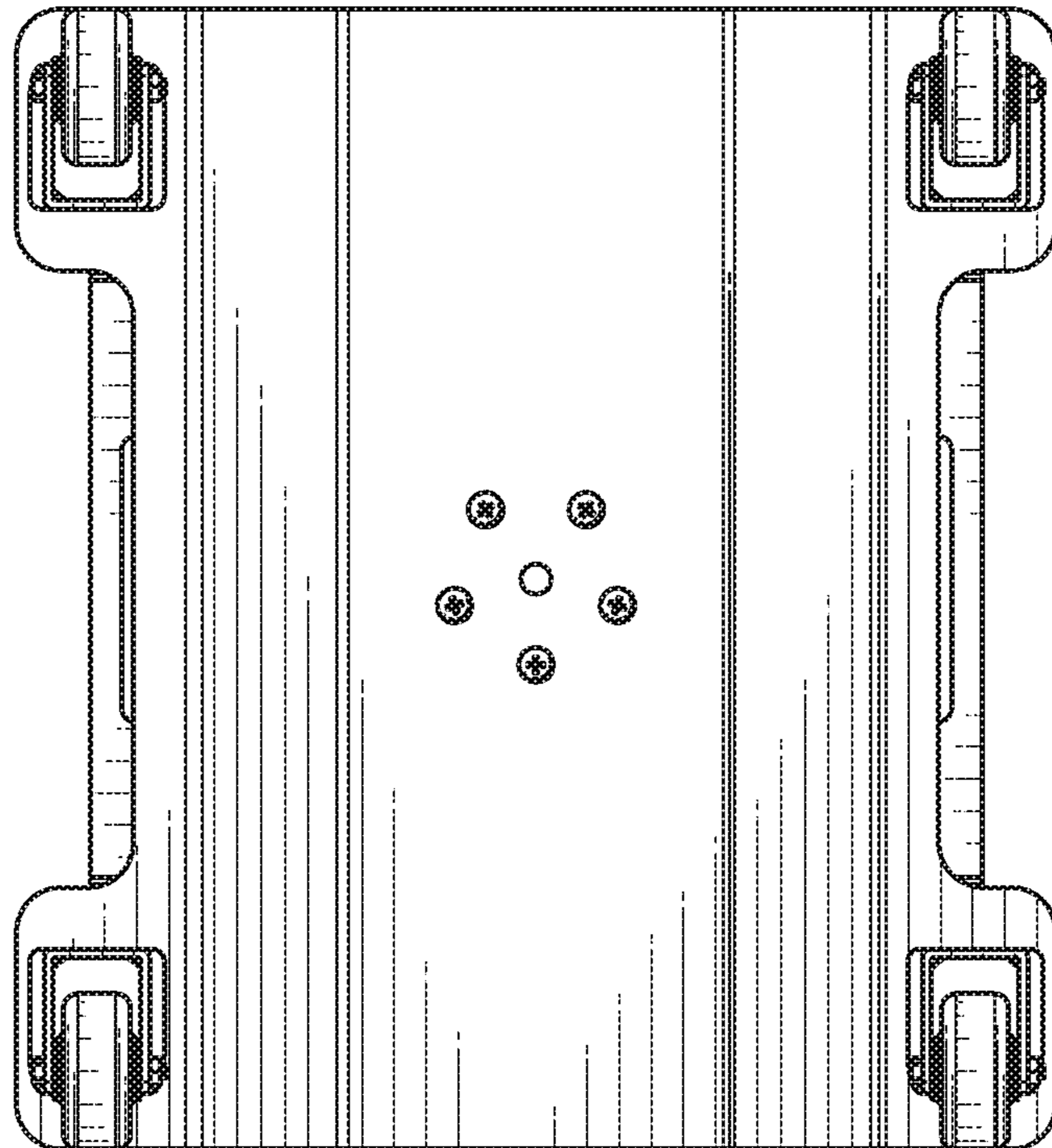

FIG. 7

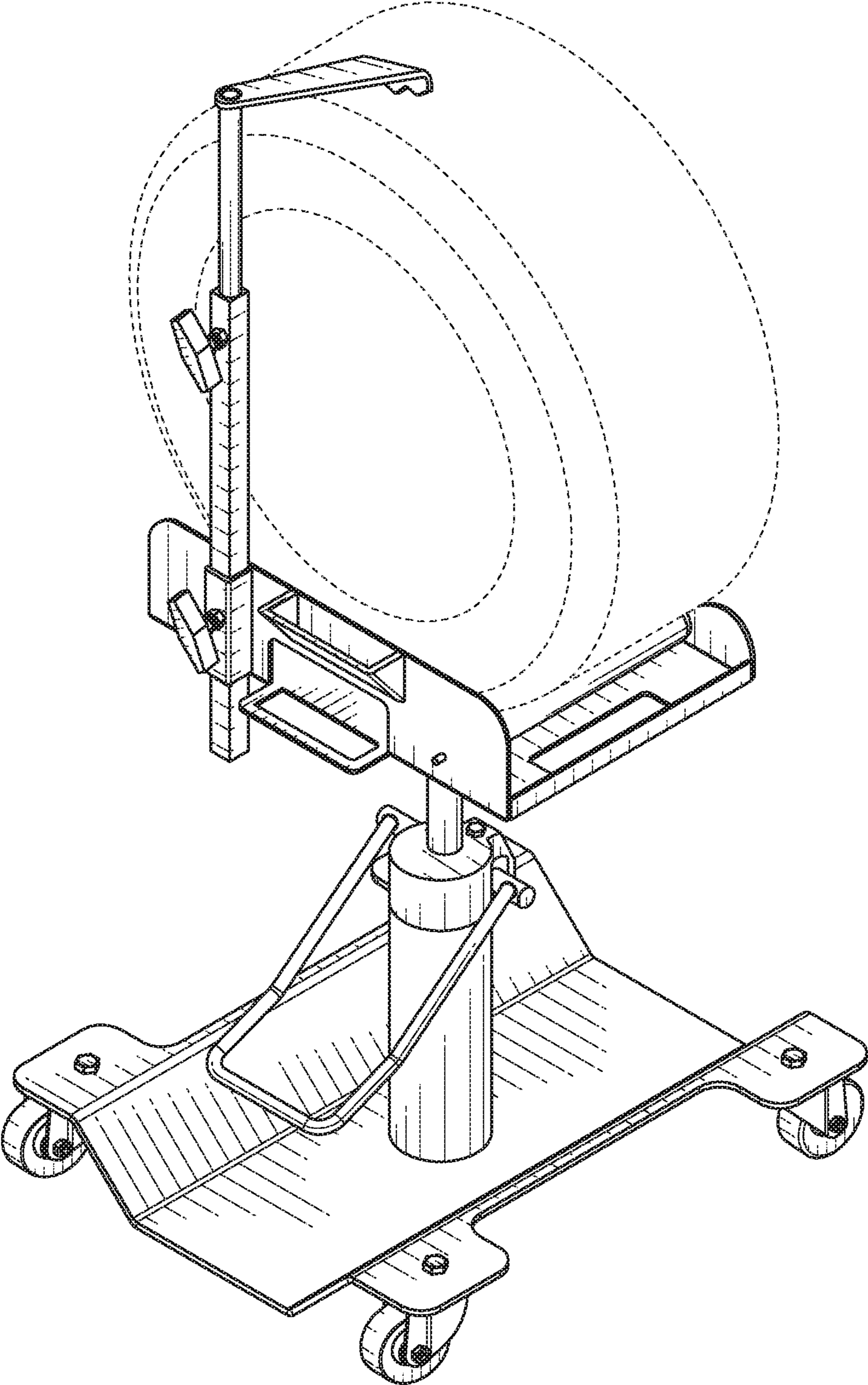

FIG. 8

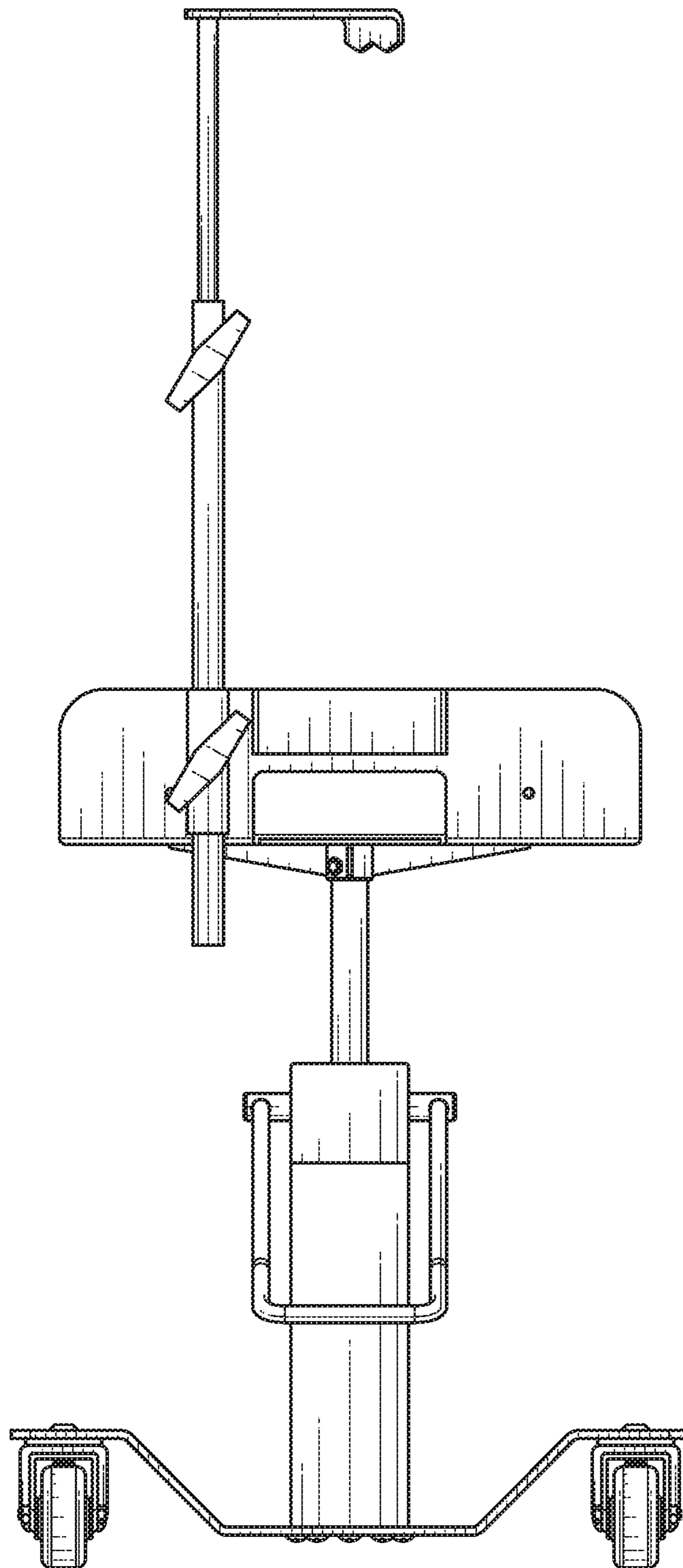

FIG. 9

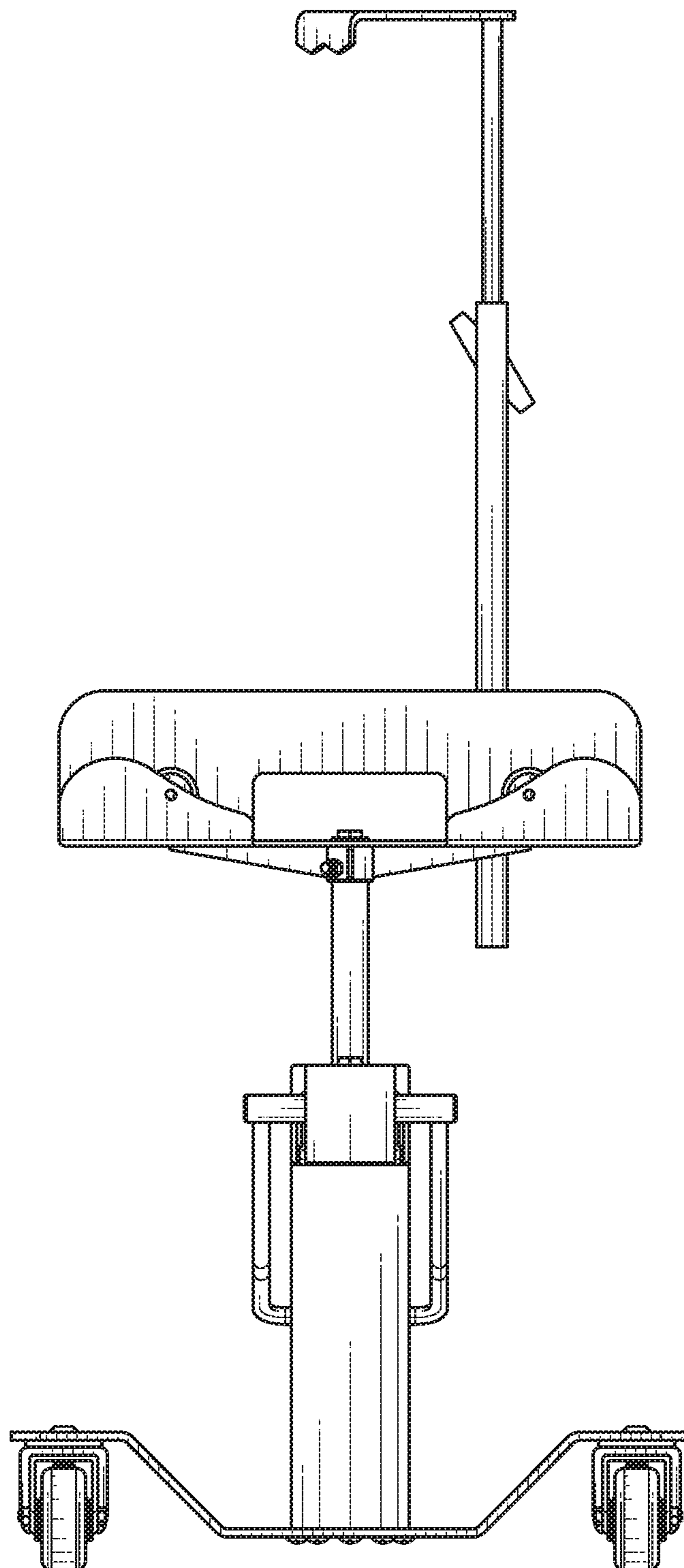

FIG. 10

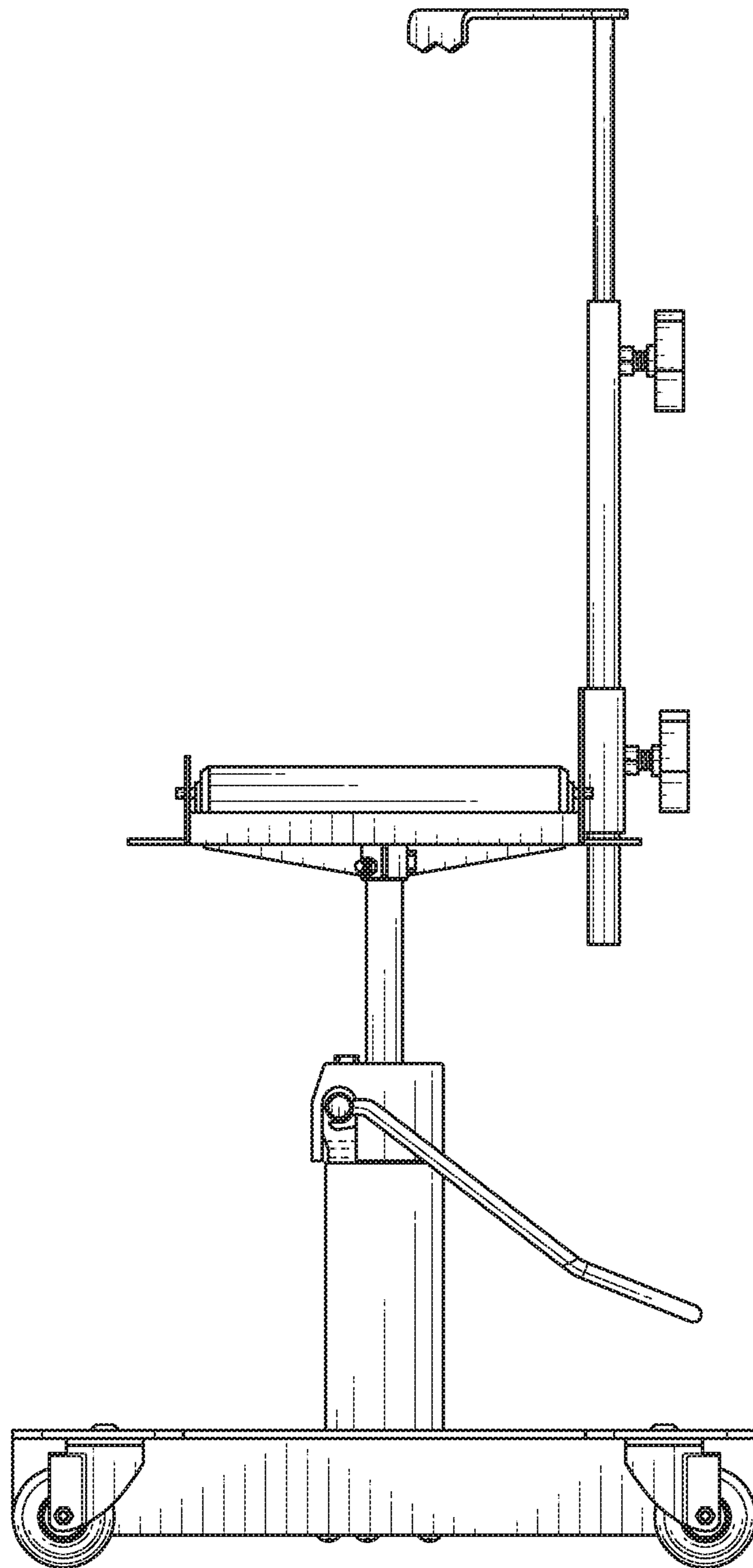

FIG. 11

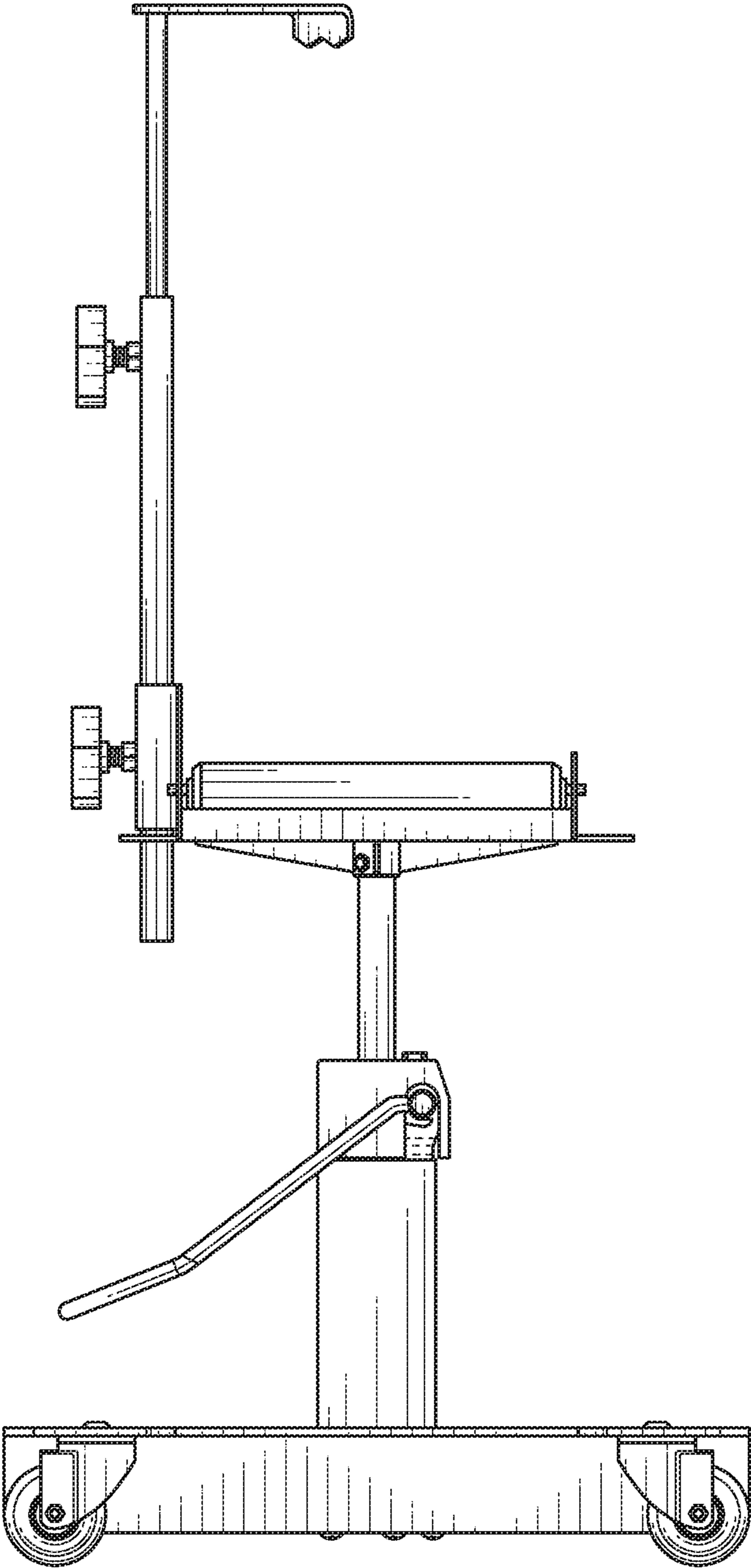

FIG. 12

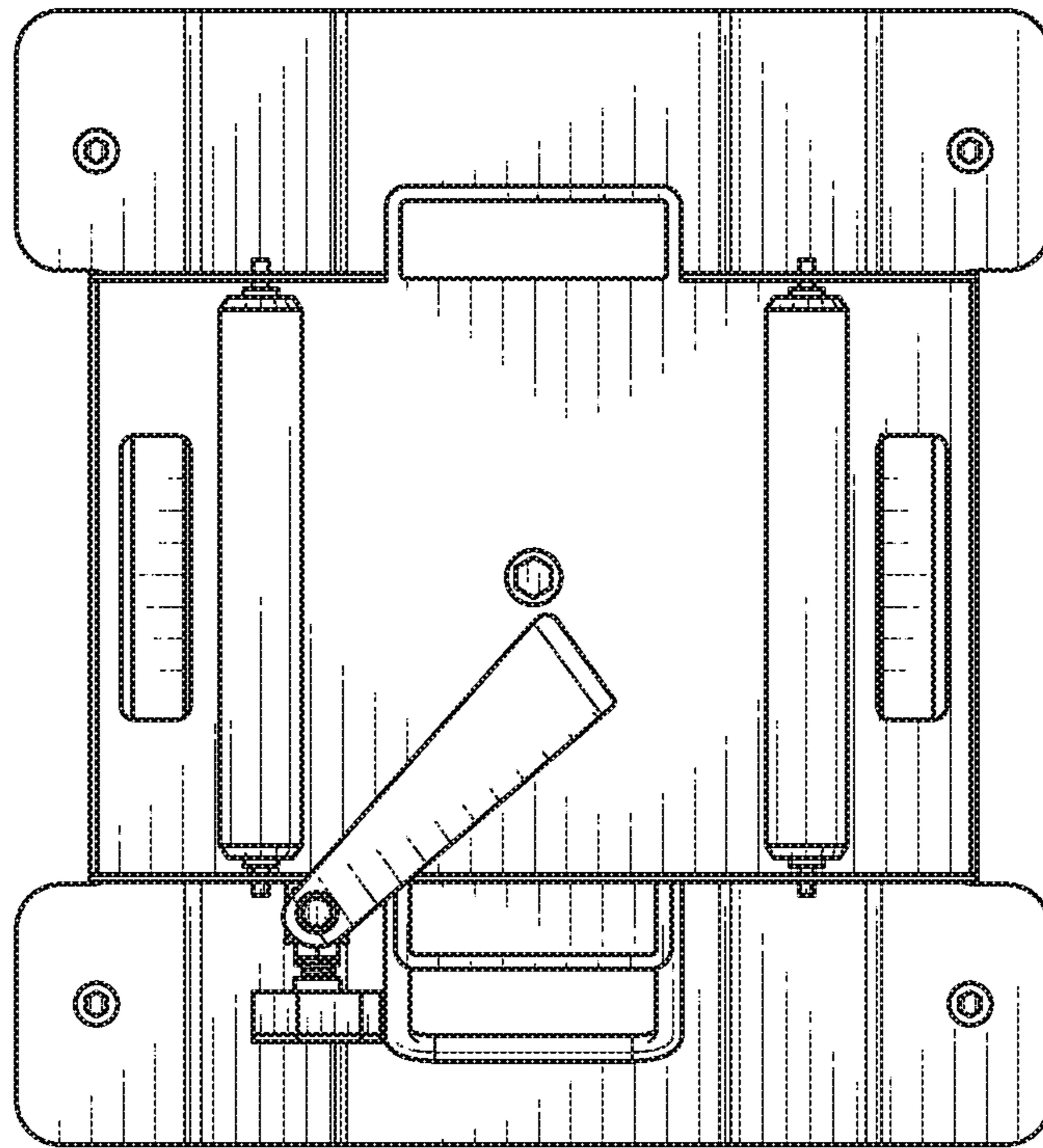

FIG. 13

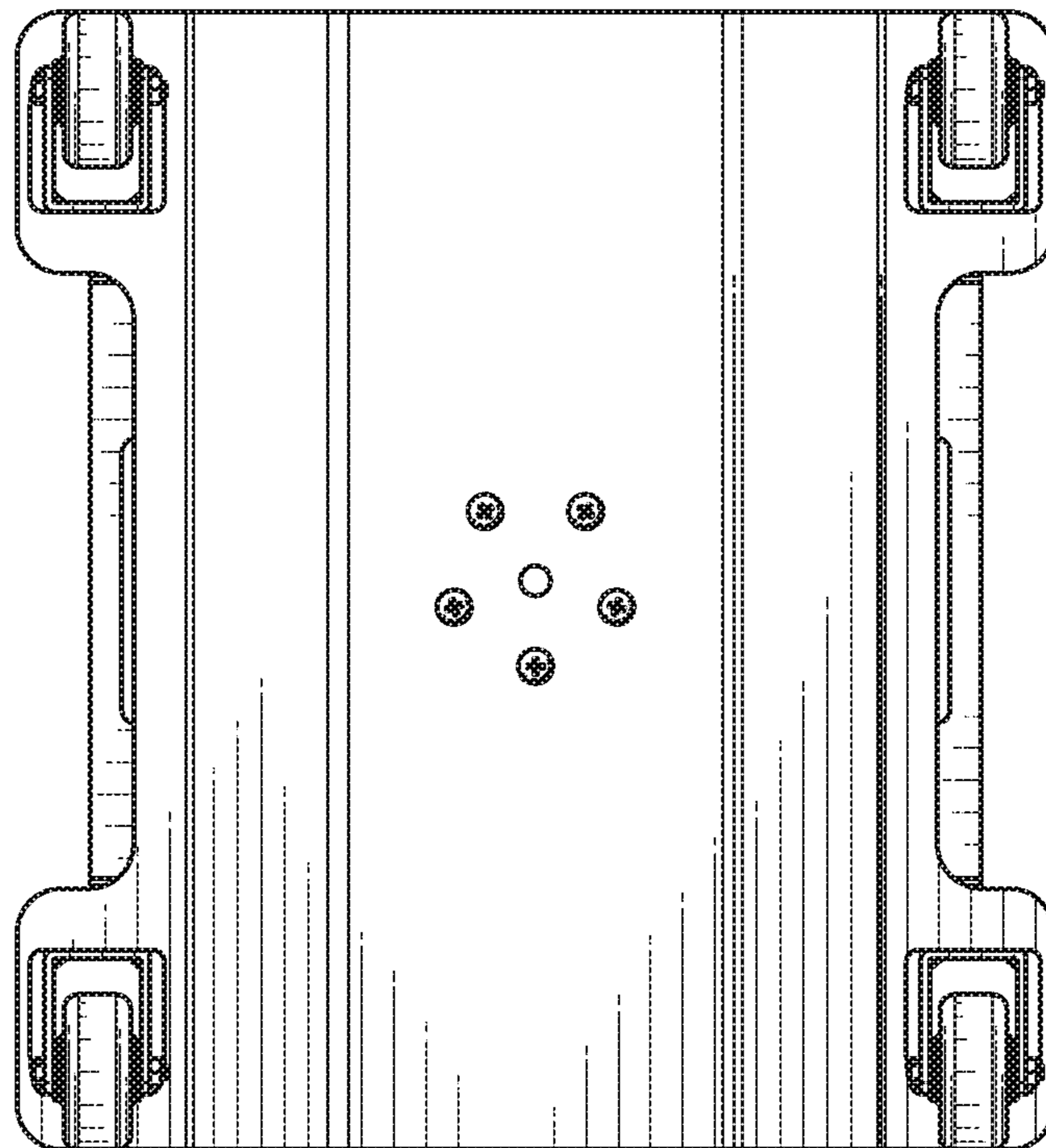

FIG. 14