



US00D870824S

(12) **United States Design Patent**  
**Barajas et al.**

(10) **Patent No.:** **US D870,824 S**

(45) **Date of Patent:** **\*\* Dec. 24, 2019**

- (54) **BODY FOR A MODEL VEHICLE**
- (71) Applicant: **TRAXXAS LP**, McKinney, TX (US)
- (72) Inventors: **Jaime Felix Barajas**, Dallas, TX (US);  
**Kent Poteet**, Lucas, TX (US); **Otto Karl Allmendinger**, Rowlett, TX (US)
- (73) Assignee: **TRAXXAS LP**, McKinney, TX (US)
- (\*\*) Term: **15 Years**

5,228,880 A 7/1993 Meyer et al.  
 5,334,078 A 8/1994 Hippely et al.  
 D385,245 S 10/1997 Gallitzendoerfer et al.  
 (Continued)

- (21) Appl. No.: **29/623,924**
- (22) Filed: **Oct. 27, 2017**
- (51) **LOC (12) Cl.** ..... **21-01**
- (52) **U.S. Cl.**  
USPC ..... **D21/562**; D21/552
- (58) **Field of Classification Search**  
USPC ..... D12/86, 88, 90-92, 164, 173, 184-186,  
D12/190, 196; D21/419, 421, 423,  
D21/424-426, 433-434, 548, 549, 550,  
D21/552, 559, 561  
CPC .... A63H 17/26; A63H 17/262; A63H 17/264;  
A63H 17/266; A63H 17/36; A63H 17/38;  
A63H 29/00; A63H 29/22; A63H 29/24;  
A63H 30/04  
See application file for complete search history.

**OTHER PUBLICATIONS**

Hot Wheels Skull Crusher Diecast Toy Car-Race Vehicle by Mattel-Auto Racing Toys Cars Collection, Feb. 22, 2012, [online], [Retrieved on Aug. 10, 2015] URL: <https://www.youtube.com/watch?v=fR1BWC9bqzM>.

(Continued)

*Primary Examiner* — Manpreet S Matharu  
*Assistant Examiner* — Keith J Wilson  
 (74) *Attorney, Agent, or Firm* — Daryl R. Wright; Greg Carr

(57) **CLAIM**

We claim the ornamental design for a body for a model vehicle, as shown and described.

**DESCRIPTION**

FIG. 1 is a top, left, front perspective view of a body for a model vehicle;  
 FIG. 2 is front elevation view thereof;  
 FIG. 3 is a rear elevation view thereof;  
 FIG. 4 is a right side elevation view thereof;  
 FIG. 5 is a left side elevation view thereof;  
 FIG. 6 is a top plan view thereof;  
 FIG. 7 is a bottom plan view thereof;  
 FIG. 8 is a top, right, rear perspective view; and,  
 FIG. 9 is a top, left, front perspective environmental view.  
 In the drawings, the broken line showing of features of the body for a model vehicle illustrate portions of the body for a model vehicle that form no part of the claimed design; whereas, the broken line showing of the environmental view depicts environmental subject matter and is provided for the purposes of illustrating environmental structure and context.

(56) **References Cited**

**U.S. PATENT DOCUMENTS**

- D203,841 S 2/1966 Power
- D243,595 S 3/1977 Belz
- D251,725 S 5/1979 Cesaro
- D253,406 S 11/1979 Carabetta
- D254,128 S 2/1980 Carabetta
- D277,494 S \* 2/1985 Lerch ..... D21/559
- D281,000 S \* 10/1985 Kuna ..... D21/559
- D293,310 S 12/1987 Clark et al.
- D307,248 S 4/1990 Dettling
- 5,102,367 A 4/1992 Mullaney et al.

**1 Claim, 9 Drawing Sheets**

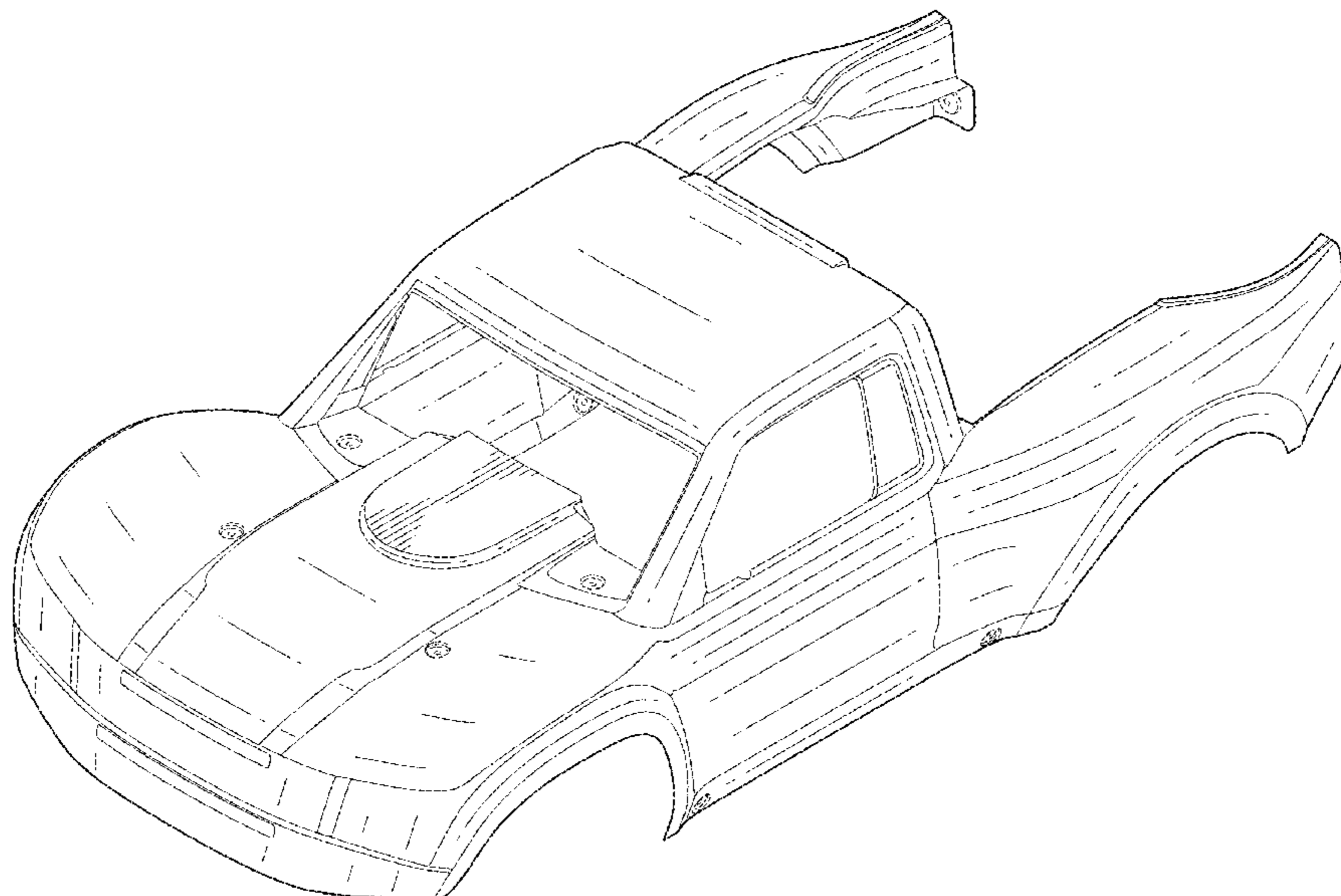

(56)

References Cited

U.S. PATENT DOCUMENTS

D404,691 S 1/1999 Gerisch et al.  
 D425,141 S 5/2000 Park  
 D458,188 S 6/2002 Wyszogrod et al.  
 D496,409 S \* 9/2004 Tilbor ..... D21/559  
 D529,967 S 10/2006 Bowen et al.  
 D538,861 S 3/2007 Takahashi  
 7,217,170 B2 5/2007 Moll et al.  
 D547,249 S \* 7/2007 Kurtz ..... D12/190  
 D550,311 S 9/2007 Chen  
 D566,788 S 4/2008 Pasko  
 D566,789 S \* 4/2008 Idiot ..... D21/552  
 D566,790 S \* 4/2008 Idiot ..... D21/552  
 D567,301 S \* 4/2008 Idiot ..... D21/549  
 7,387,558 B2 6/2008 Swisher et al.  
 D579,823 S 11/2008 Choi  
 D592,256 S 5/2009 Yaguchi  
 D593,163 S 5/2009 Torres et al.  
 D603,295 S \* 11/2009 Honeycutt ..... D12/86  
 D605,083 S \* 12/2009 Manoogian, II ..... D12/86  
 D612,767 S \* 3/2010 Barkan ..... D12/86  
 D617,851 S 6/2010 Stoddard  
 D630,971 S 1/2011 Jung  
 D671,454 S 11/2012 Davidson et al.  
 8,342,904 B2 1/2013 Torres  
 D693,737 S 11/2013 Hammoud et al.

D707,608 S 6/2014 Smith  
 D709,007 S 7/2014 Henry et al.  
 D709,008 S 7/2014 Brzustowicz et al.  
 D709,009 S 7/2014 Brzustowicz et al.  
 D728,037 S \* 4/2015 Barajas ..... D21/548  
 D741,416 S 10/2015 Barajas et al.  
 D741,956 S 10/2015 Barajas et al.  
 D769,378 S \* 10/2016 Belker ..... D21/549  
 D770,339 S 11/2016 Lindsey  
 D770,350 S 11/2016 Lindsey  
 D770,575 S \* 11/2016 Belker ..... D21/549  
 D771,202 S \* 11/2016 Gan ..... D21/552  
 D771,203 S \* 11/2016 Gan ..... D21/552  
 D792,526 S \* 7/2017 Belker ..... D21/561  
 D802,685 S \* 11/2017 Barajas ..... D21/562  
 D826,341 S 8/2018 Poteet et al.  
 D826,342 S 8/2018 Poteet et al.  
 D826,343 S 8/2018 Poteet et al.  
 D827,056 S 8/2018 Poteet et al.  
 D841,743 S 2/2019 Barajas et al.  
 D842,386 S 3/2019 Barajas et al.  
 D842,387 S 3/2019 Barajas et al.

OTHER PUBLICATIONS

PROTOform; Protoform Ford GT 2017; <http://racepf.com/on-road-1-10-1-12/ford-gt-clear-body/>; Sep. 2016.

\* cited by examiner

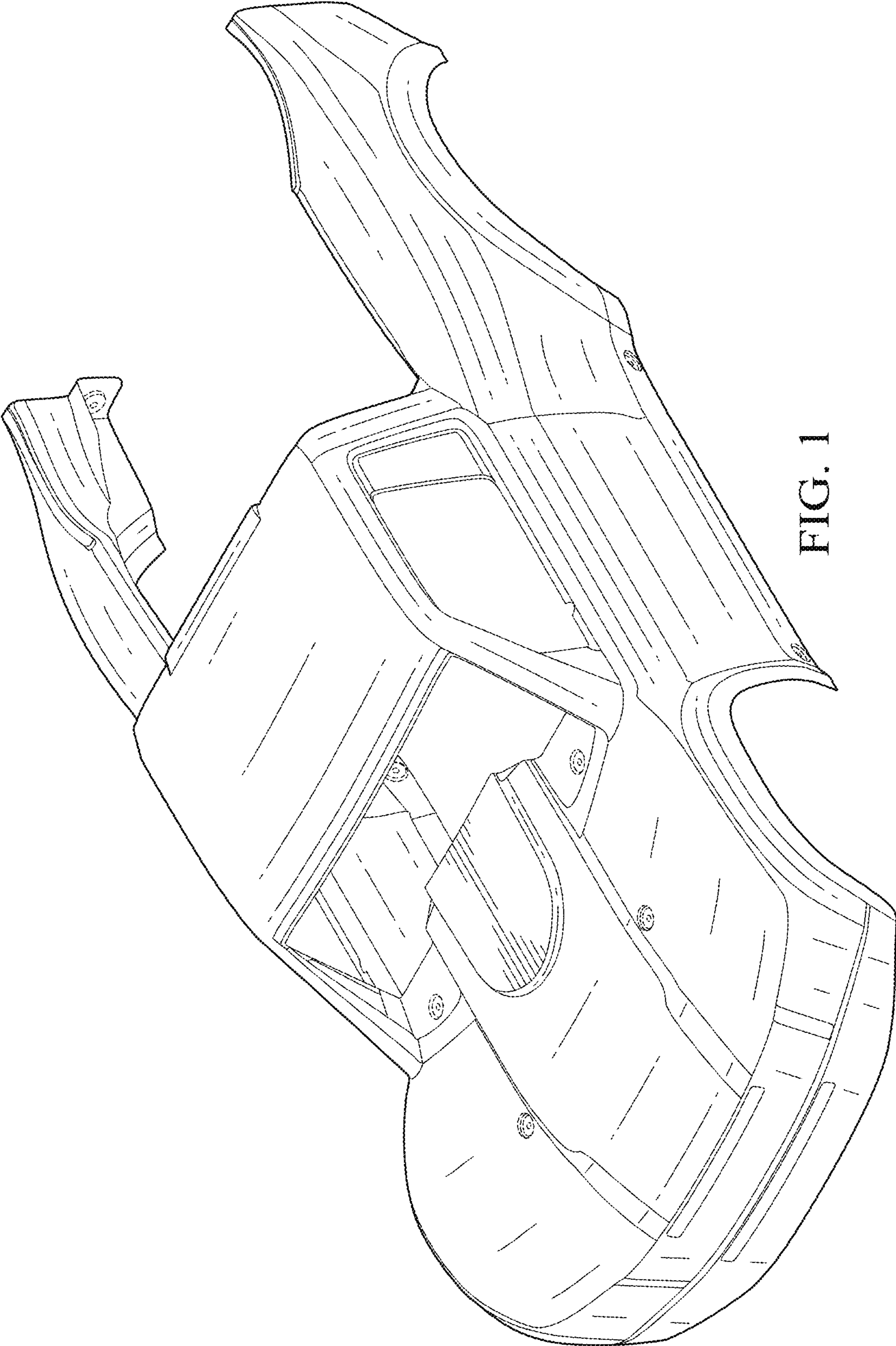

FIG. 1

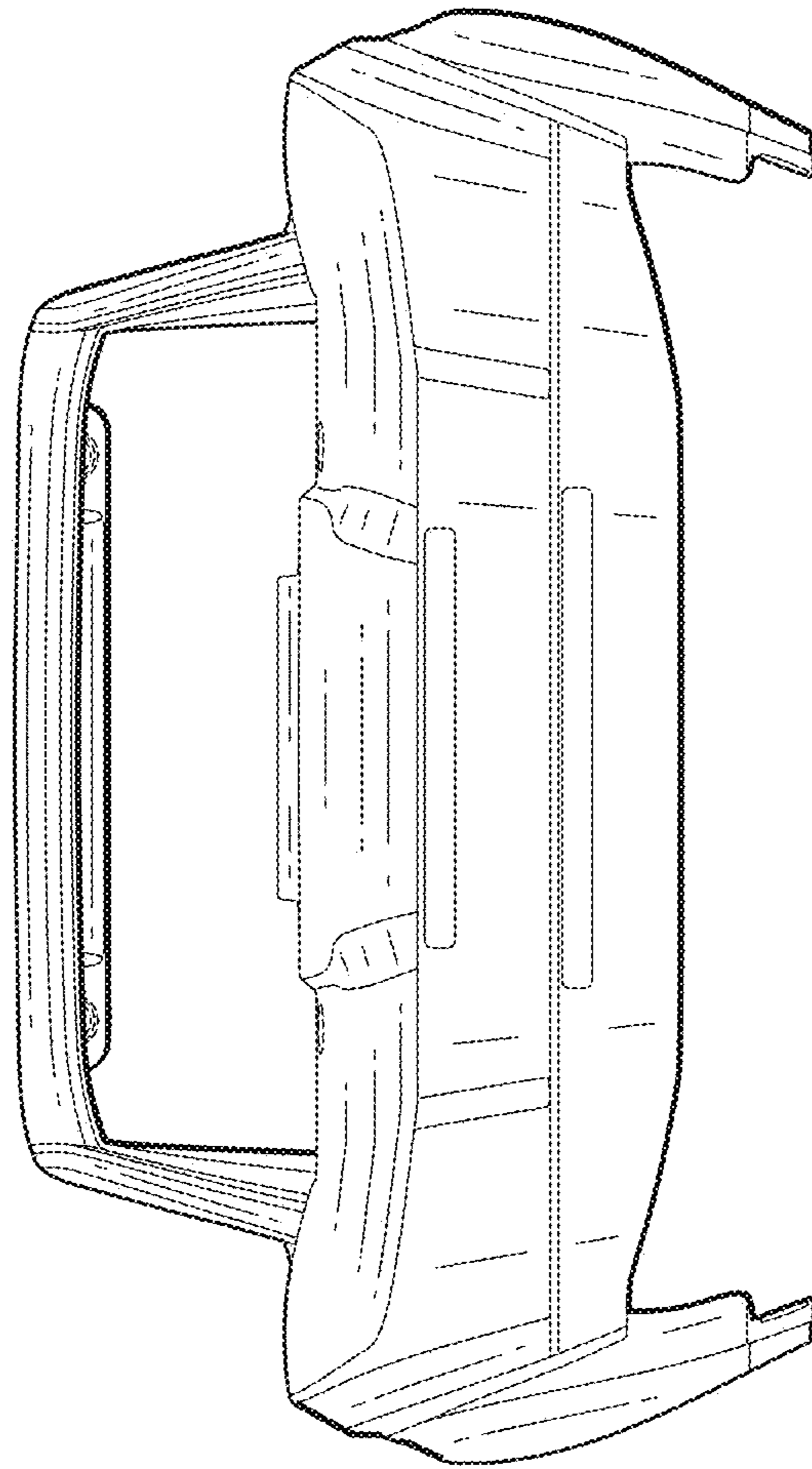

FIG. 2

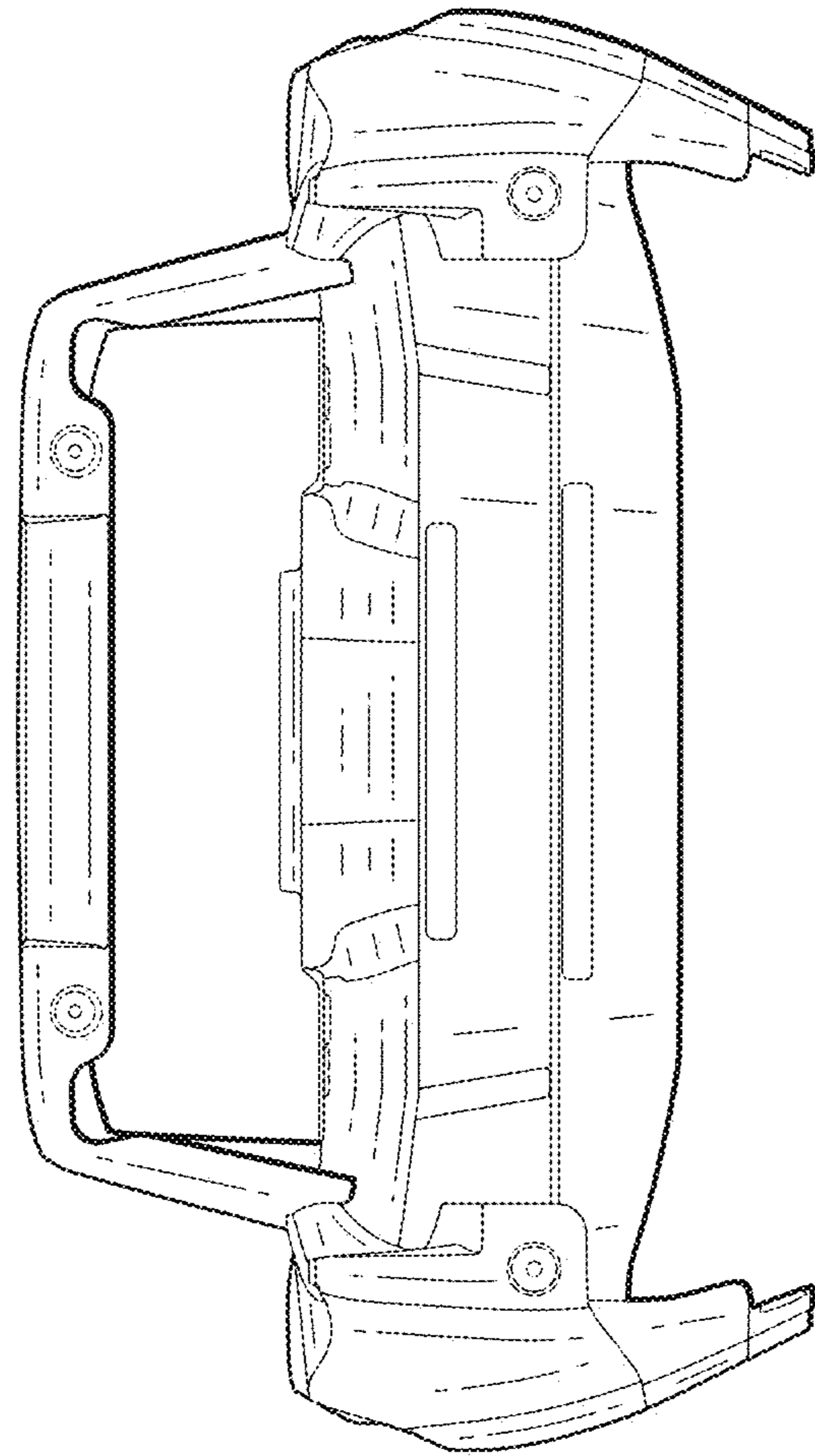

FIG. 3

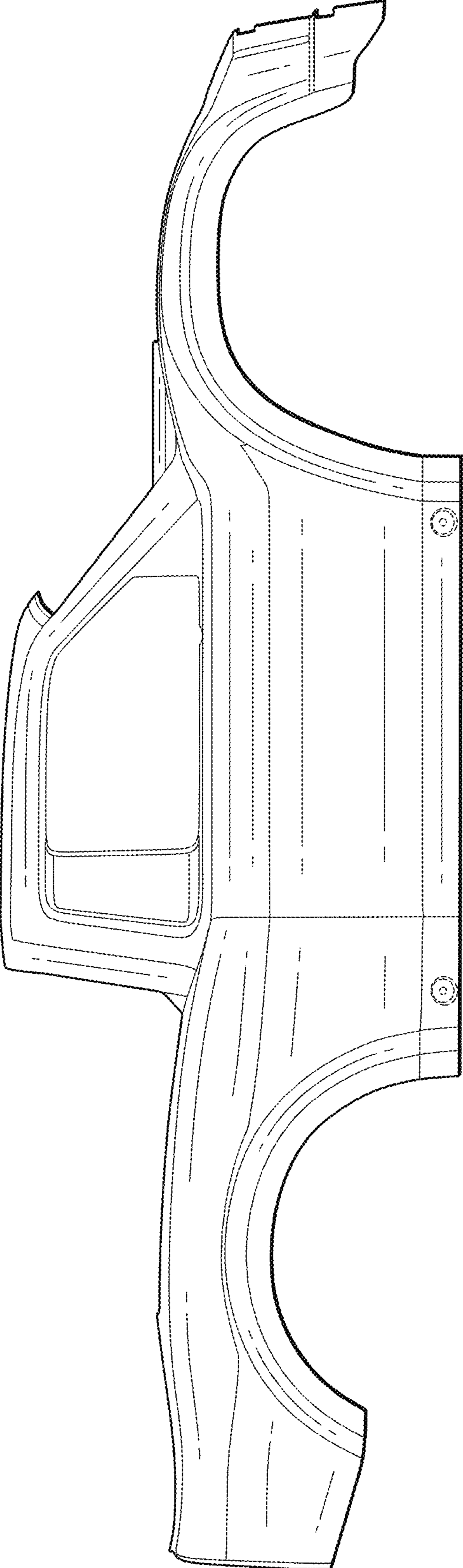

FIG. 4

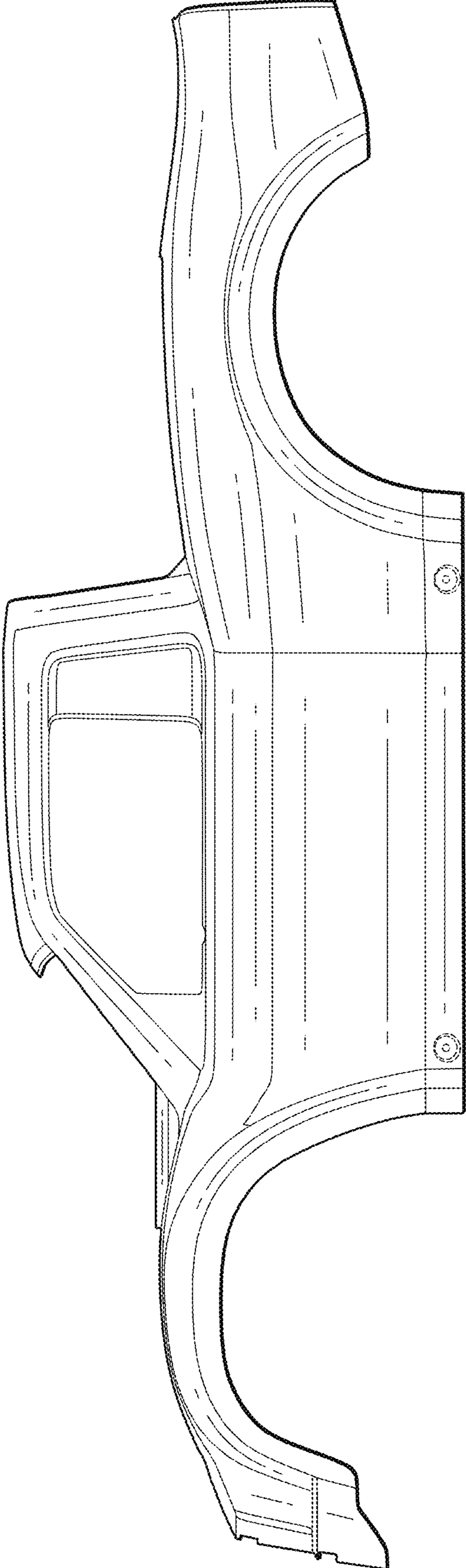

FIG. 5

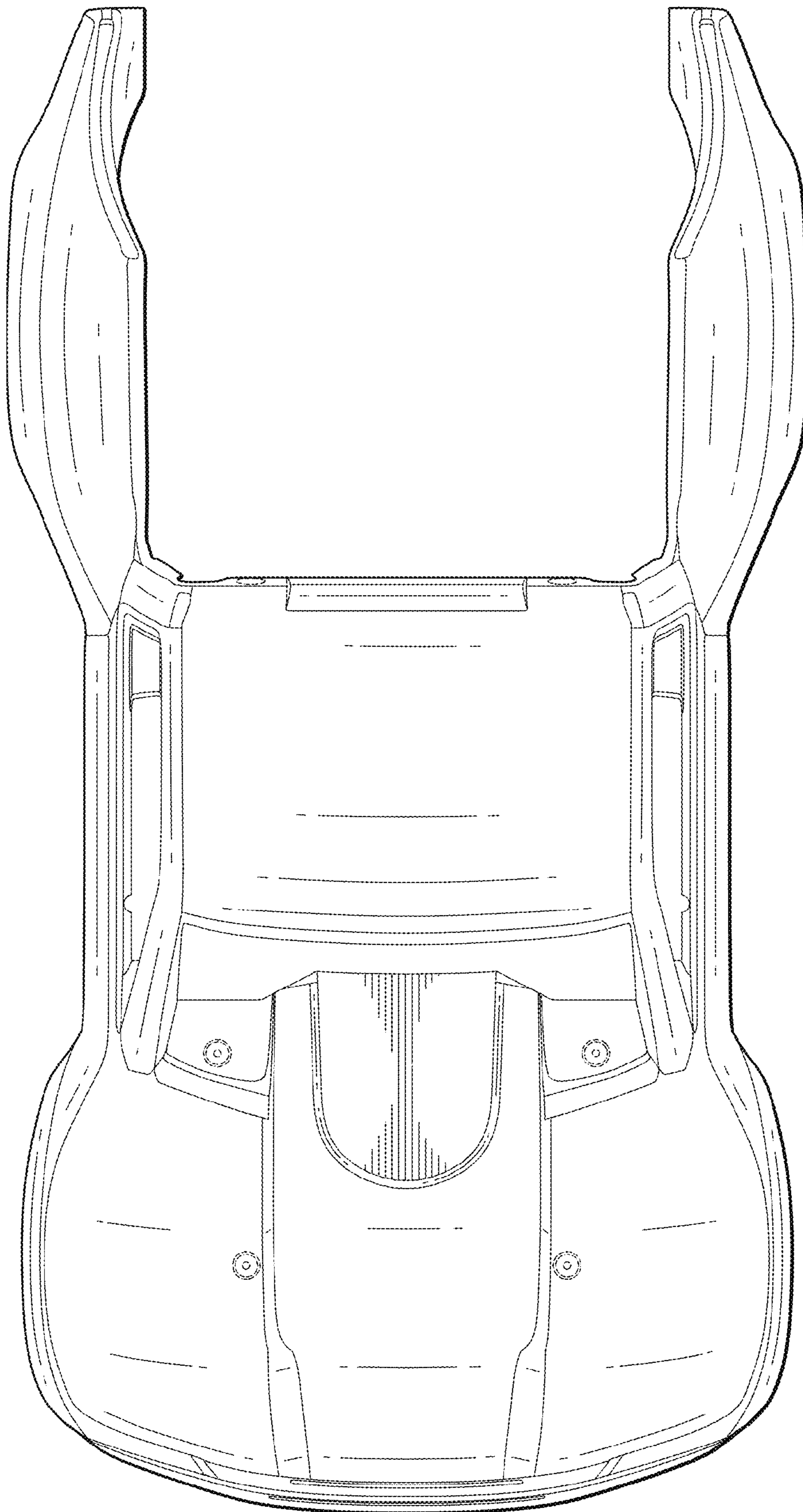

FIG. 6



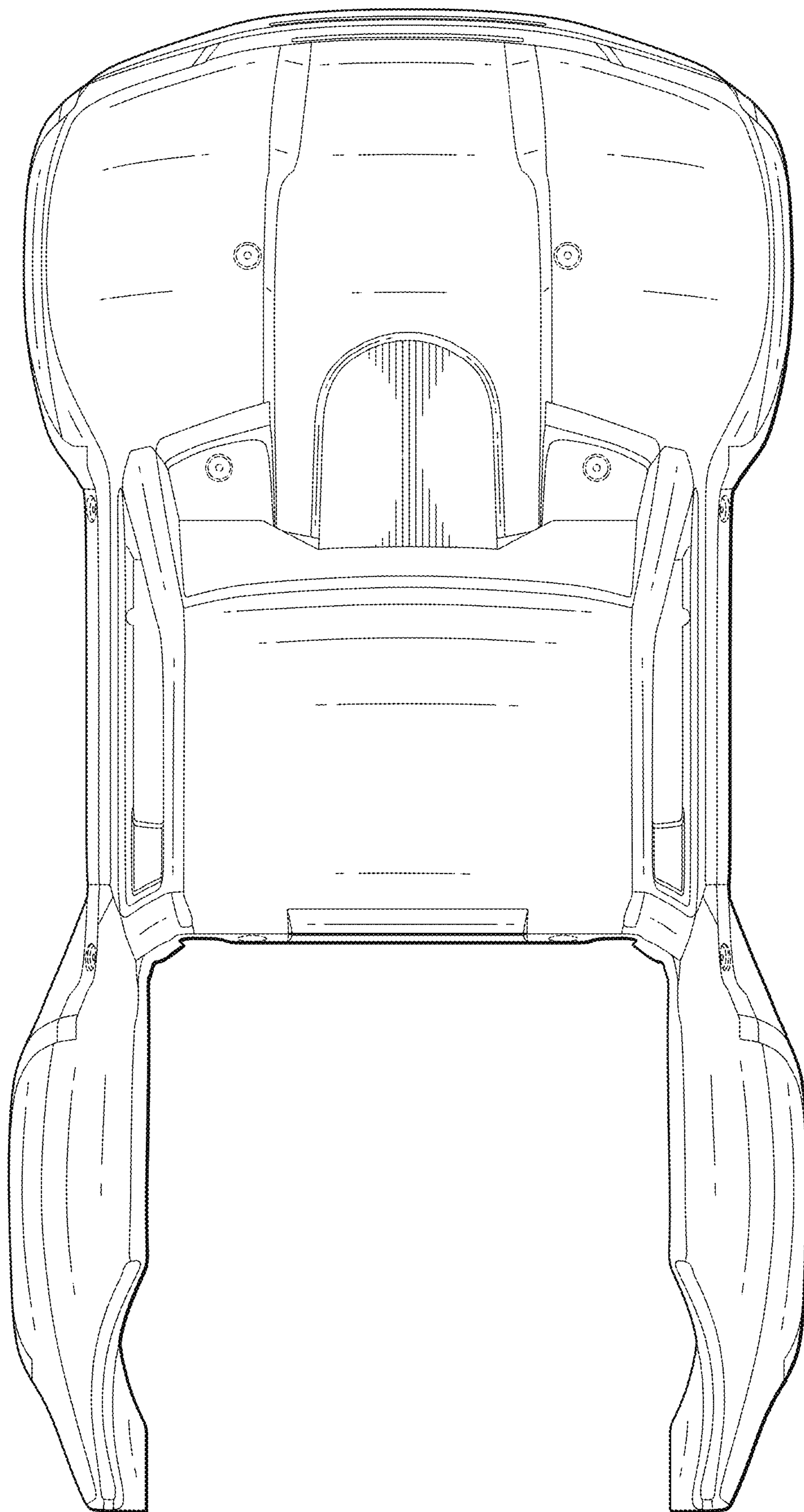

FIG. 7

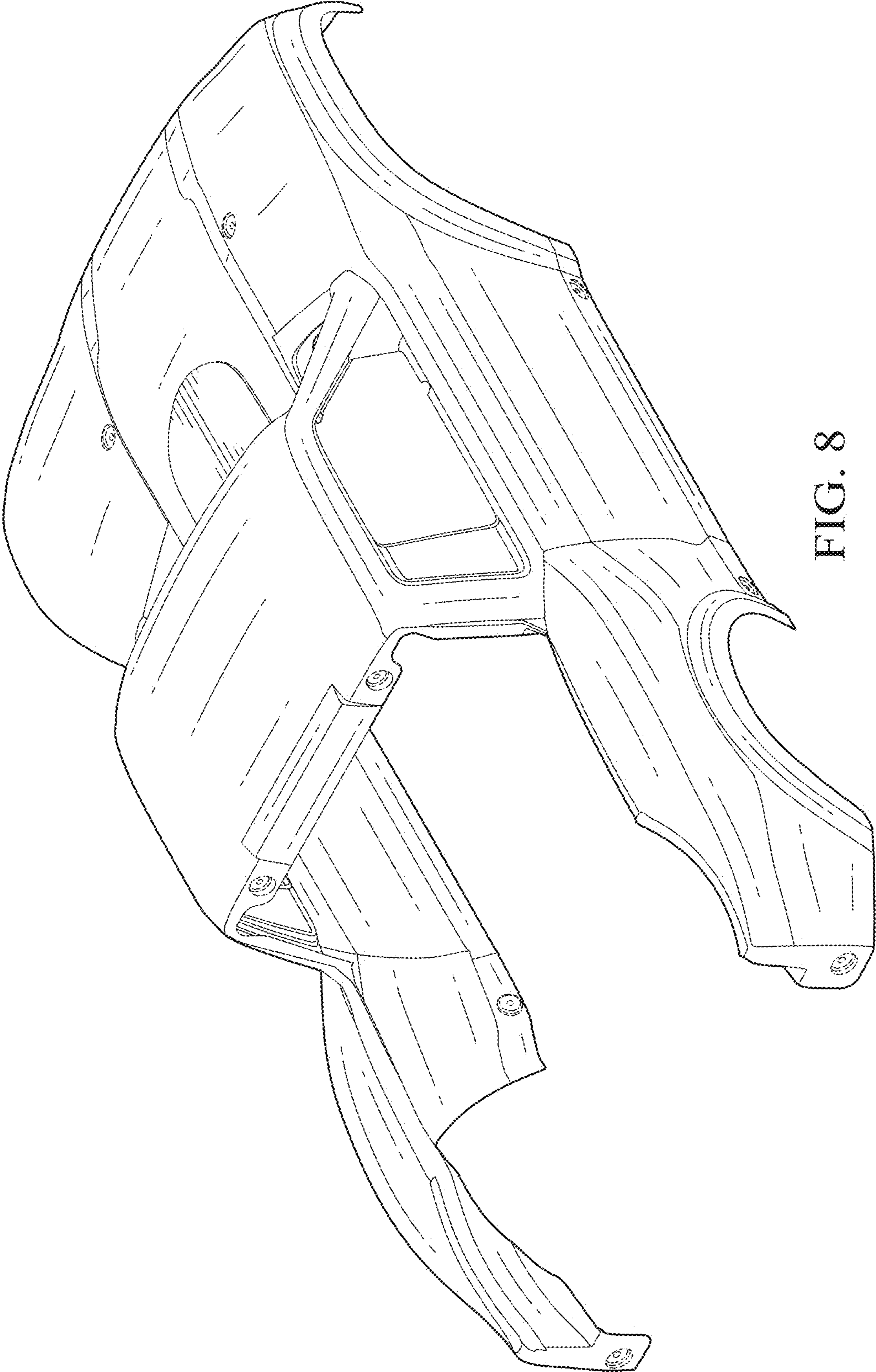

FIG. 8

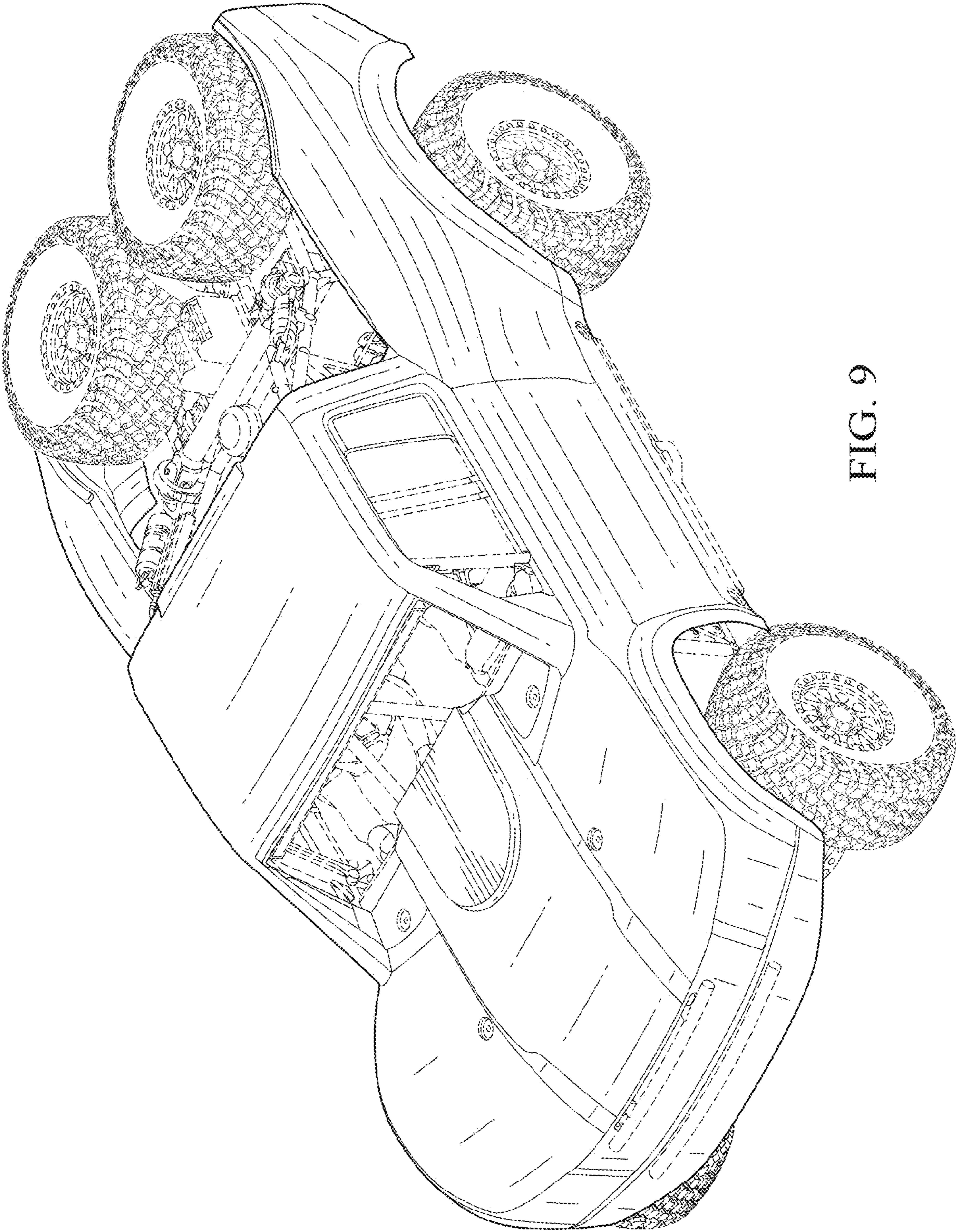

FIG. 9