



US00D870786S

(12) **United States Design Patent** (10) **Patent No.:** **US D870,786 S**
Wu (45) **Date of Patent:** **** Dec. 24, 2019**

(54) **OIL CATCH CAN**
(71) Applicant: **Advanced Development Depot, Inc,**
Rancho Cucamonga, CA (US)
(72) Inventor: **Chuan-Hsing Wu,** Rancho Cucamonga,
CA (US)

D337,774 S * 7/1993 Schillinger D15/150
5,486,290 A * 1/1996 McGinness B01D 29/072
210/323.2
D374,447 S * 10/1996 Brewer D15/150
D379,097 S * 5/1997 Brewer D15/150
5,634,502 A * 6/1997 Pierce F01M 11/04
141/331
D396,868 S * 8/1998 Pingel D15/151
D422,914 S * 4/2000 Lasky D9/451

(**) Term: **15 Years**

(Continued)

(21) Appl. No.: **29/636,924**

Primary Examiner — Patricia A Palasik

(22) Filed: **Feb. 12, 2018**

(74) Attorney, Agent, or Firm — Tsz Lung Yeung

(51) **LOC (12) Cl.** **15-09**

(57) **CLAIM**

(52) **U.S. Cl.**
USPC **D15/150**

The ornamental design for an oil catch can, as shown and described.

(58) **Field of Classification Search**
USPC D15/150, 151, 152; D23/209, 211
CPC F01M 9/00; F01M 9/06; F01M 9/002
See application file for complete search history.

DESCRIPTION

(56) **References Cited**

U.S. PATENT DOCUMENTS

1,506,028 A * 8/1924 Perritt F16N 31/002
184/1.5
1,990,524 A * 2/1935 Bystricky F16N 5/00
138/34
D129,867 S * 10/1941 Dunmire D15/150
D145,692 S * 10/1946 Fitzpatrick D15/151
D232,976 S * 9/1974 Ruter D15/5
D264,614 S * 5/1982 Johnson, Sr. D23/209
D280,757 S * 9/1985 Paulovich D23/207
4,702,290 A * 10/1987 Perez B67D 7/00
141/332
4,775,067 A * 10/1988 Mount B65D 25/00
137/312
D307,913 S * 5/1990 Ogasawara D15/150
D309,974 S * 8/1990 Tannous D23/209
D311,239 S * 10/1990 Lundquist D23/209
D317,315 S * 6/1991 Miyake D15/150
D332,300 S * 1/1993 Eastom D23/211.2
D337,594 S * 7/1993 Strauch D15/152

FIG. 1 is a perspective view of an oil catch can according to a first embodiment of my new design;
FIG. 2 is a front view thereof;
FIG. 3 is a rear view thereof;
FIG. 4 is a right side view thereof;
FIG. 5 is a left side view thereof;
FIG. 6 is a top view thereof;
FIG. 7 is a bottom view thereof;
FIG. 8 is a rear perspective view thereof;
FIG. 9 is perspective view of an oil catch can according to a second embodiment of my new design;
FIG. 10 is a front view thereof;
FIG. 11 is a rear view thereof;
FIG. 12 is a right side view thereof;
FIG. 13 is a left side view thereof;
FIG. 14 is a top view thereof;
FIG. 15 is a bottom view thereof; and,
FIG. 16 is a rear perspective view thereof.
The broken lines in the drawings represent unclaimed environmental subject matter that forms no part of the claim.

1 Claim, 16 Drawing Sheets

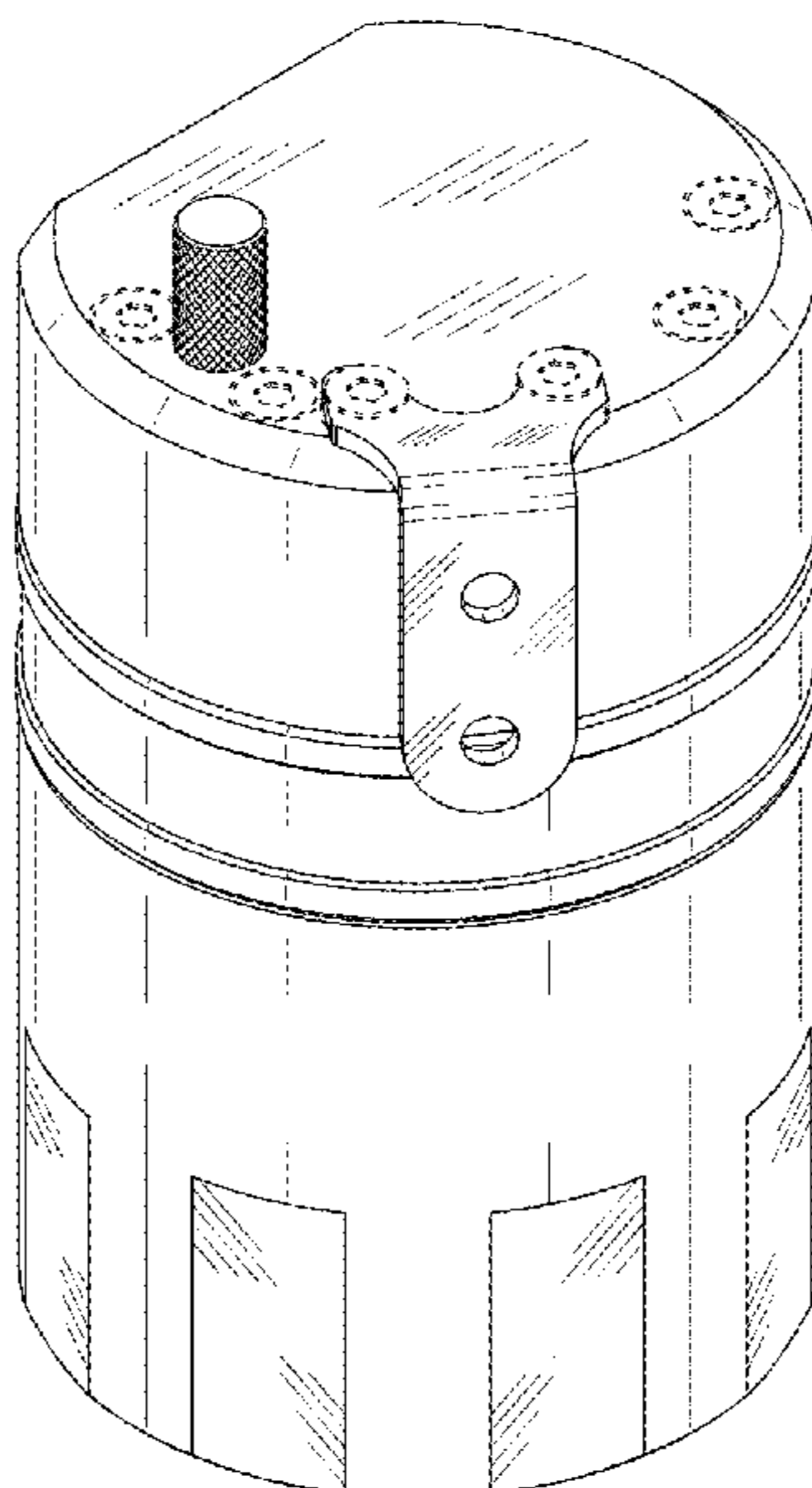

(56)

References Cited

U.S. PATENT DOCUMENTS

D438,932	S	*	3/2001	McKinney	D23/207
D460,146	S	*	7/2002	Setser	D23/209
D510,587	S	*	10/2005	Tigerholm	D15/150
D518,555	S	*	4/2006	De Muro, Jr.	D23/209
D539,822	S	*	4/2007	Tseng	D15/150
D562,429	S	*	2/2008	Morris	B01D 27/06
						D23/209
D621,001	S	*	8/2010	Maziel	D23/209
D638,042	S	*	5/2011	Liao	D15/152
D650,402	S	*	12/2011	Yamase	D15/150
D650,403	S	*	12/2011	Yamase	D15/150
D717,913	S	*	11/2014	Lin	D15/152
D727,462	S	*	4/2015	Antonucci	D23/209
D728,069	S	*	4/2015	Moore	D23/209
D817,440	S	*	5/2018	Lossie	D23/209
D823,916	S	*	7/2018	Lee	D15/150
D831,428	S	*	10/2018	Gibson	D7/533

* cited by examiner

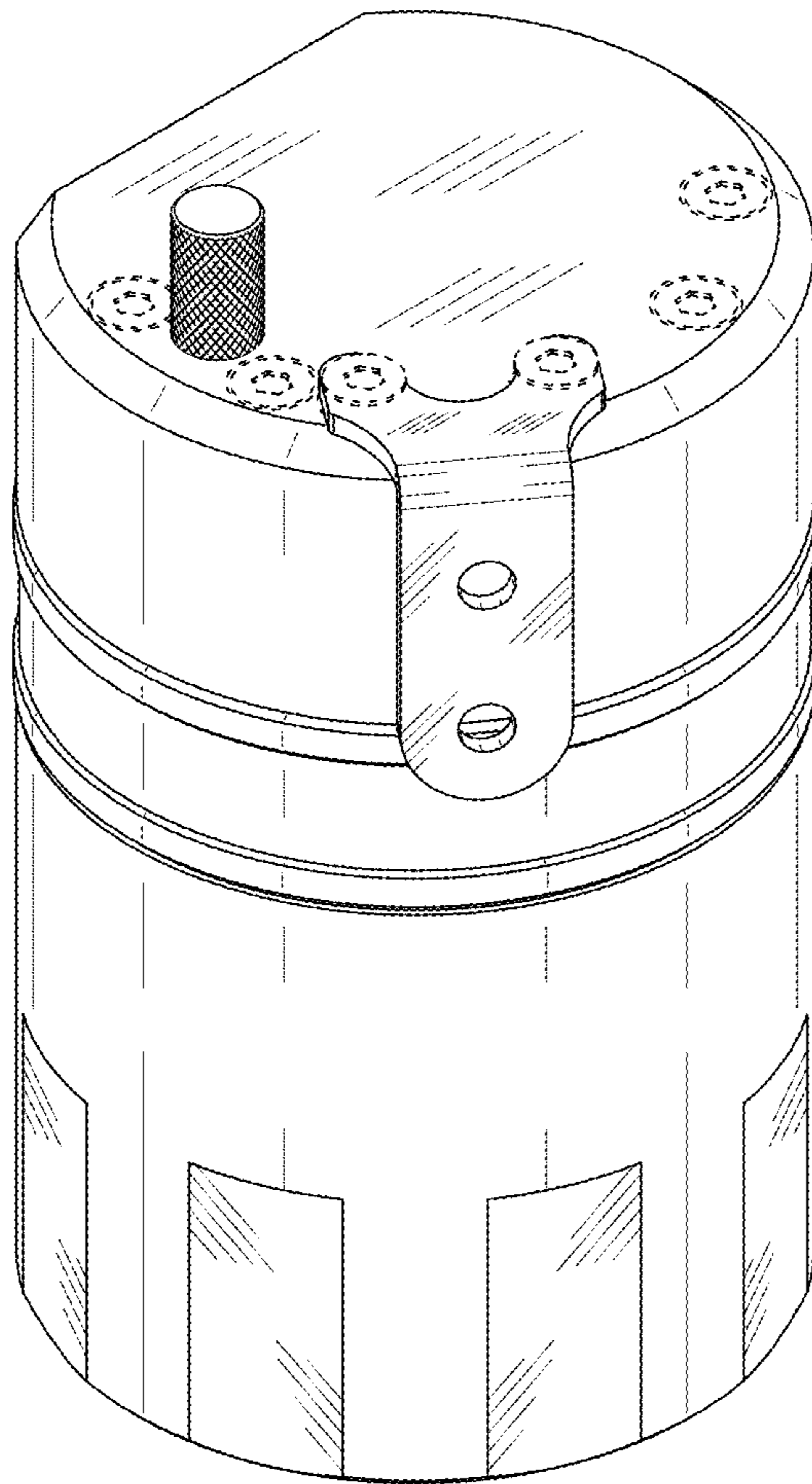

FIG. 1

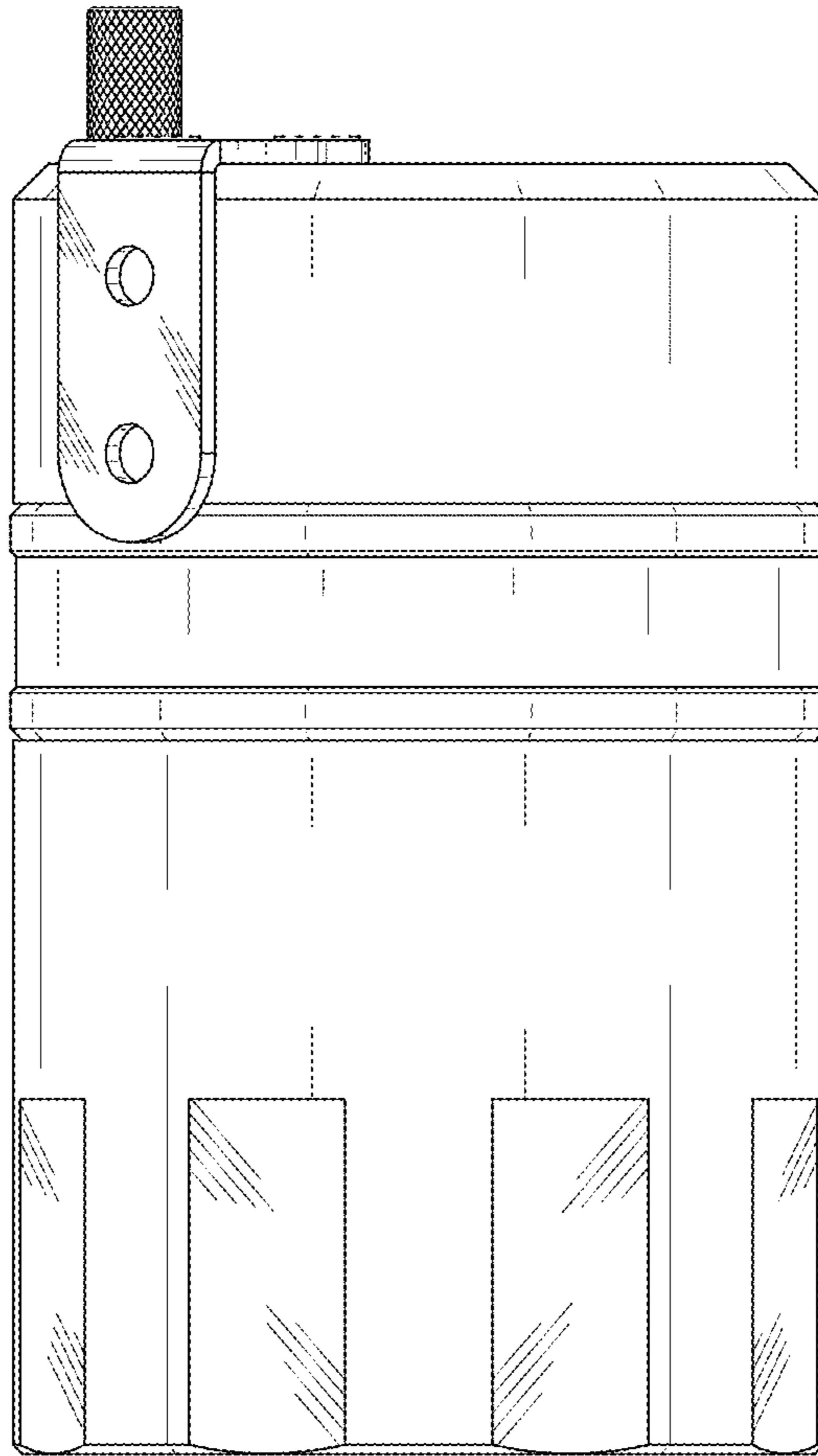

FIG. 2

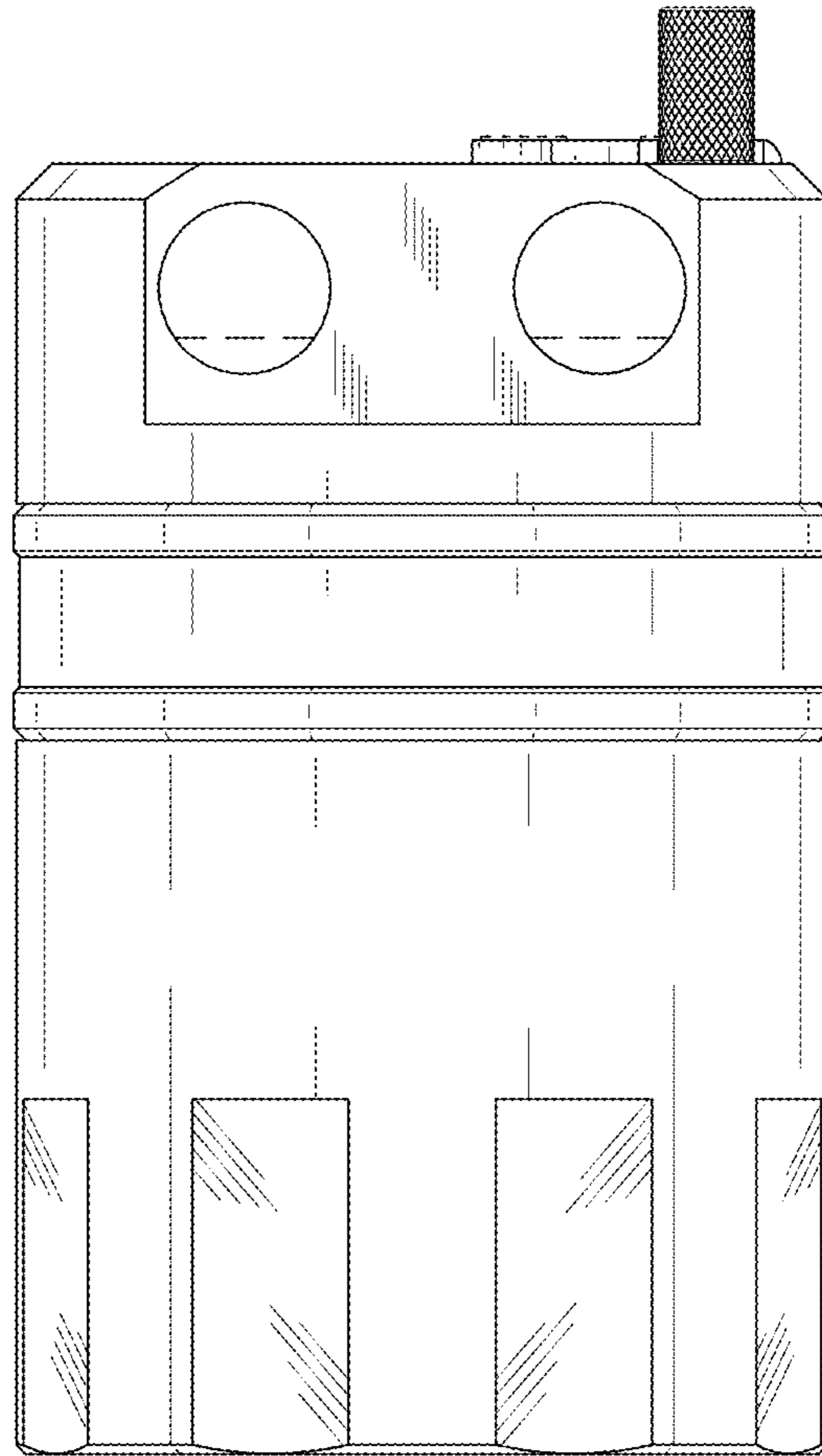

FIG. 3

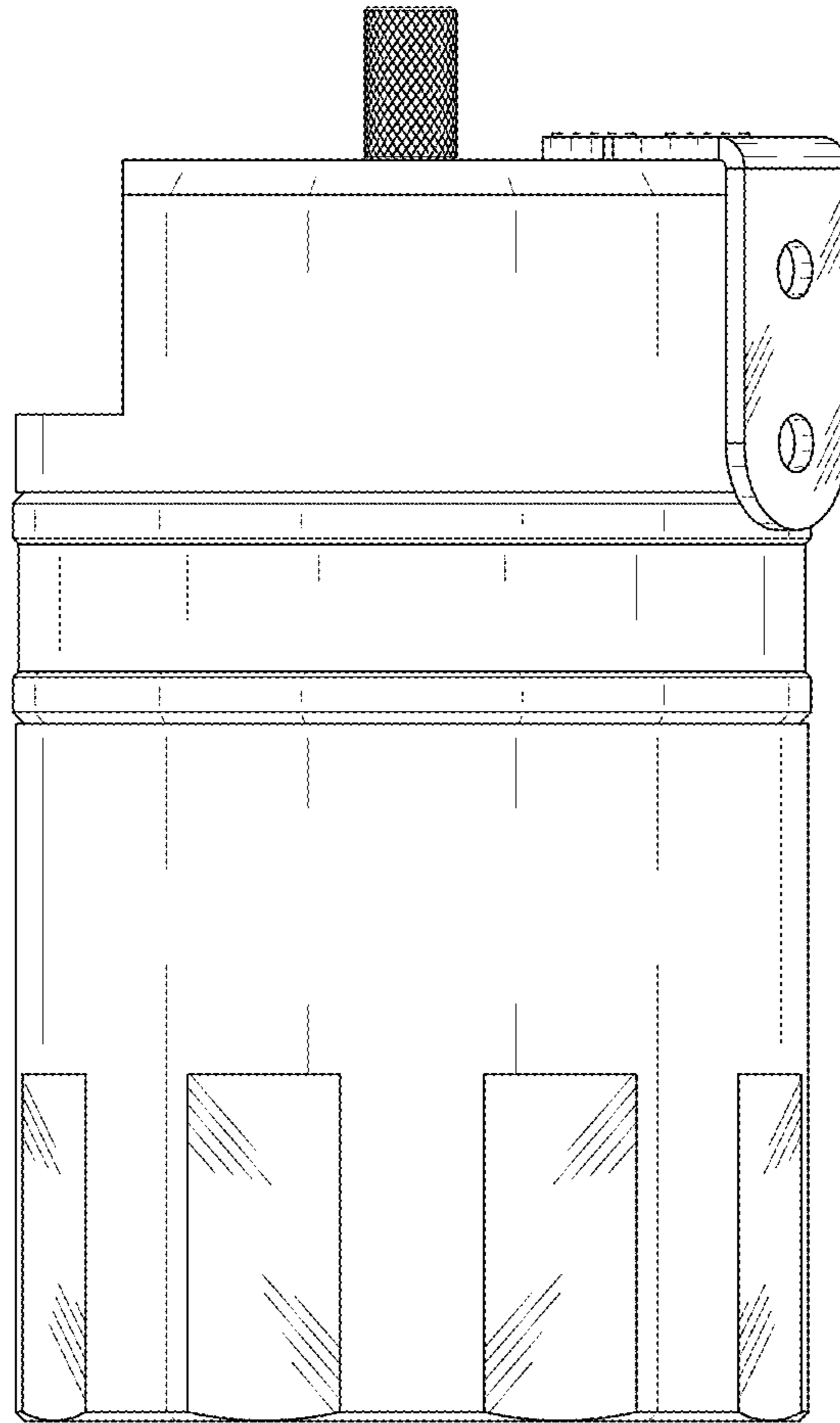

FIG. 4

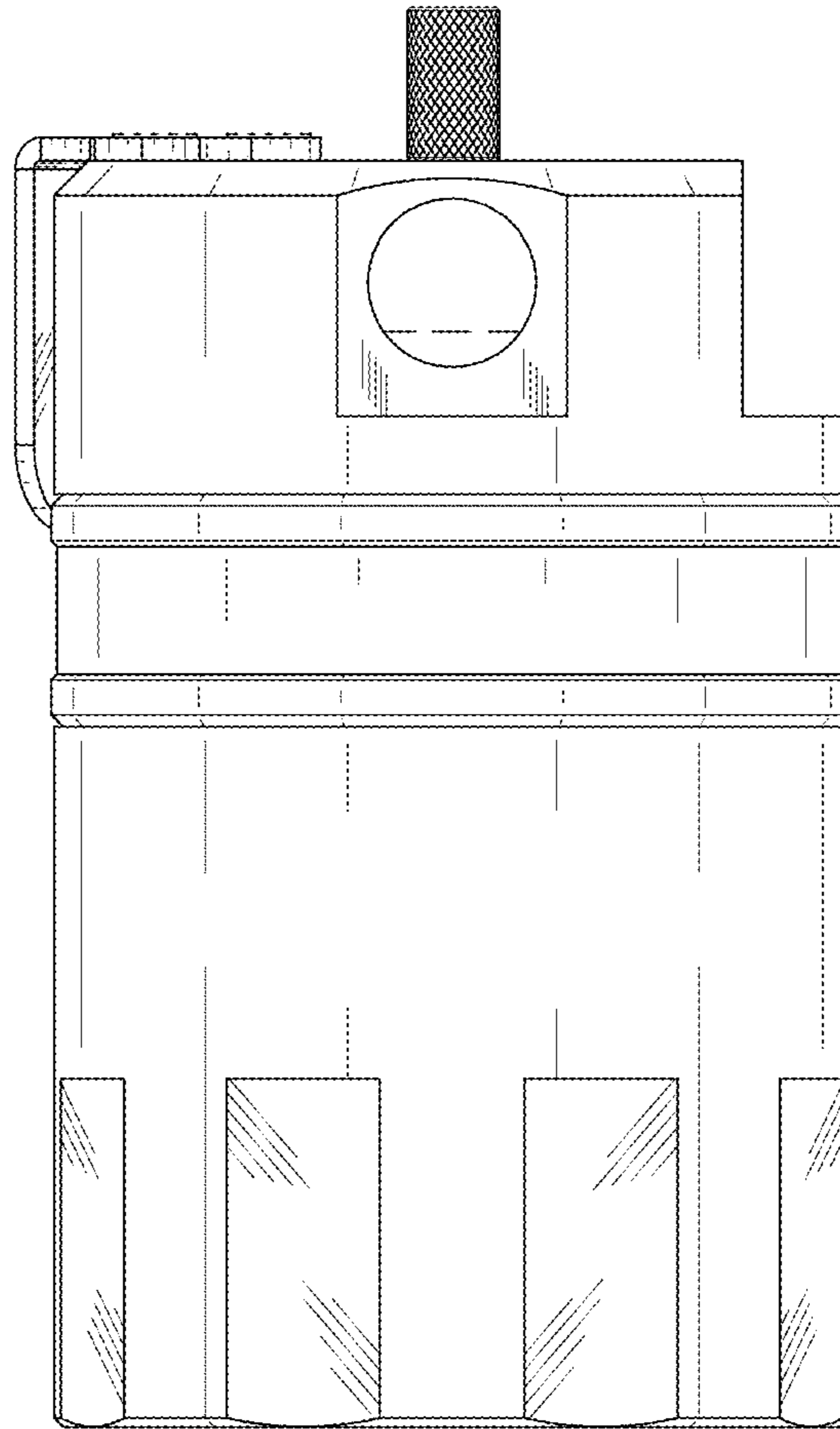

FIG. 5

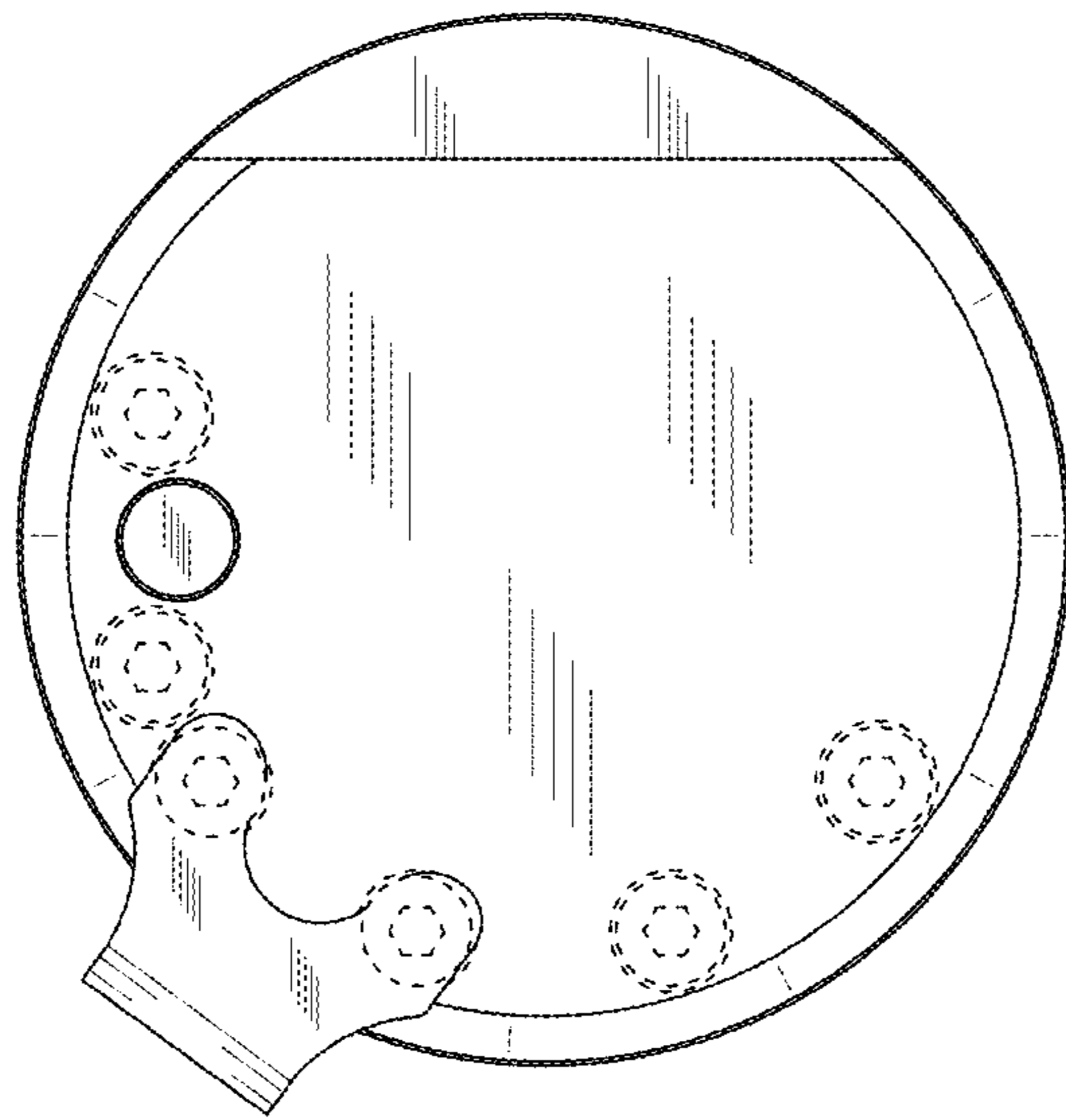

FIG. 6

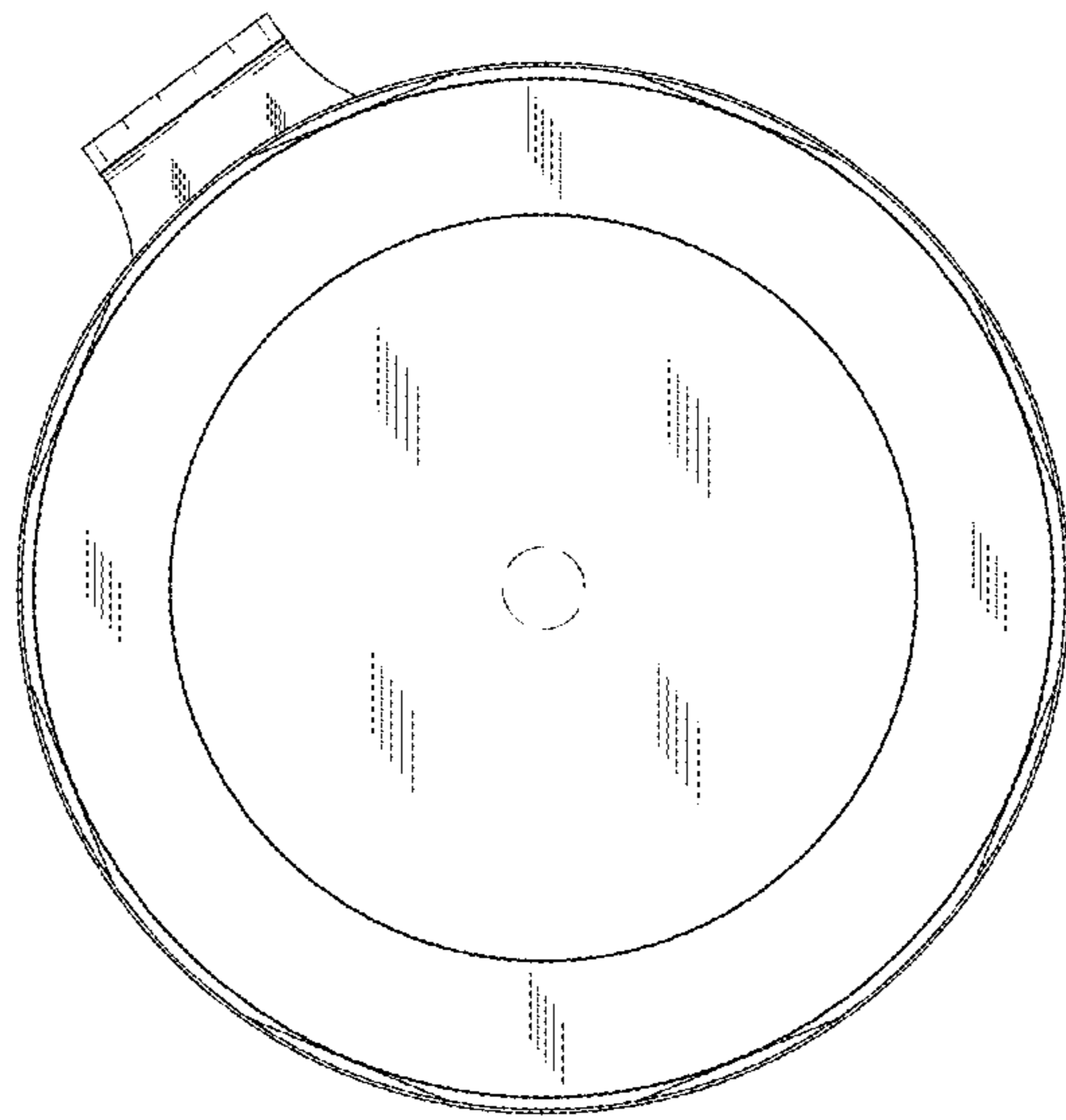

FIG. 7

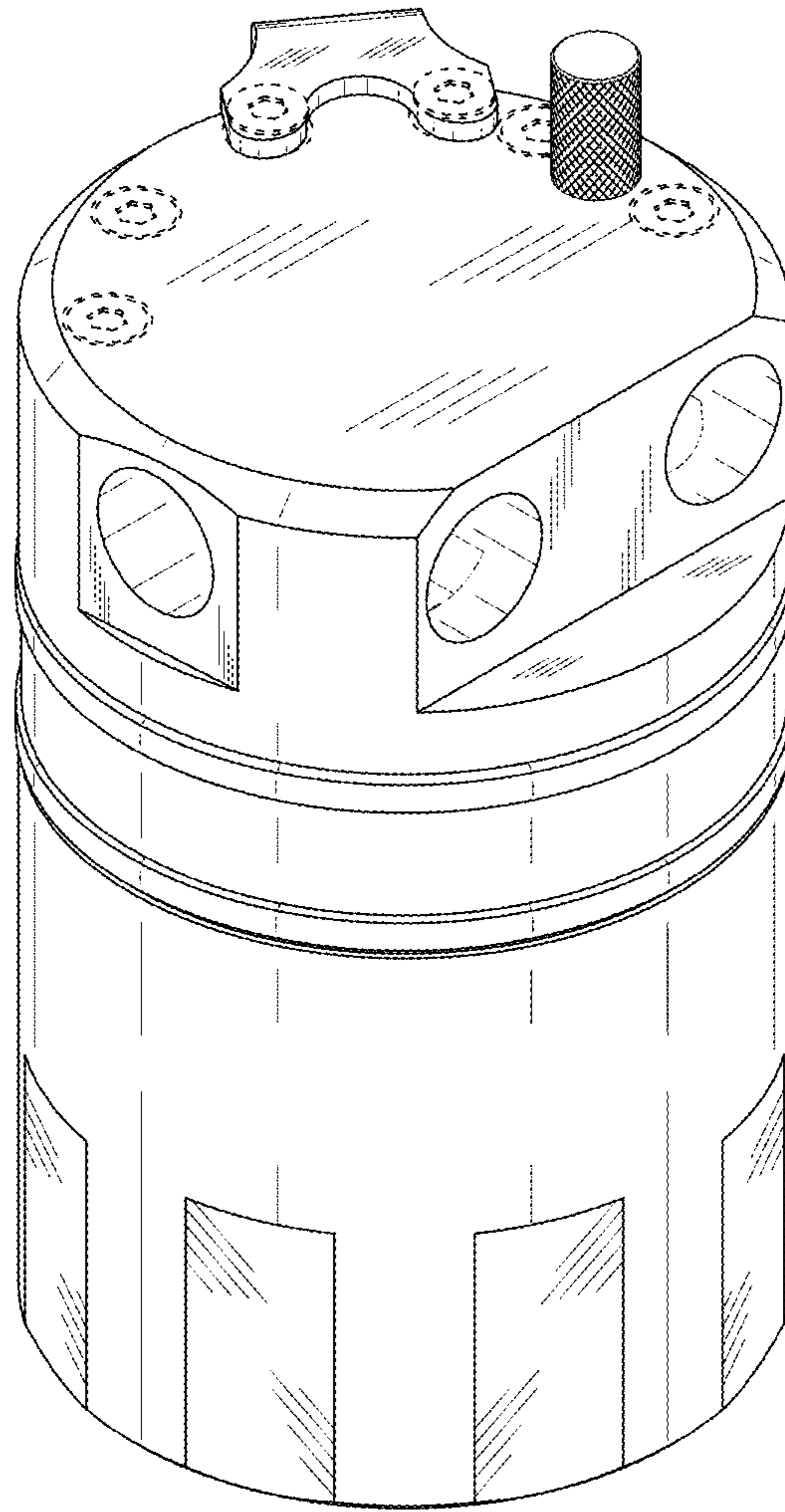

FIG. 8

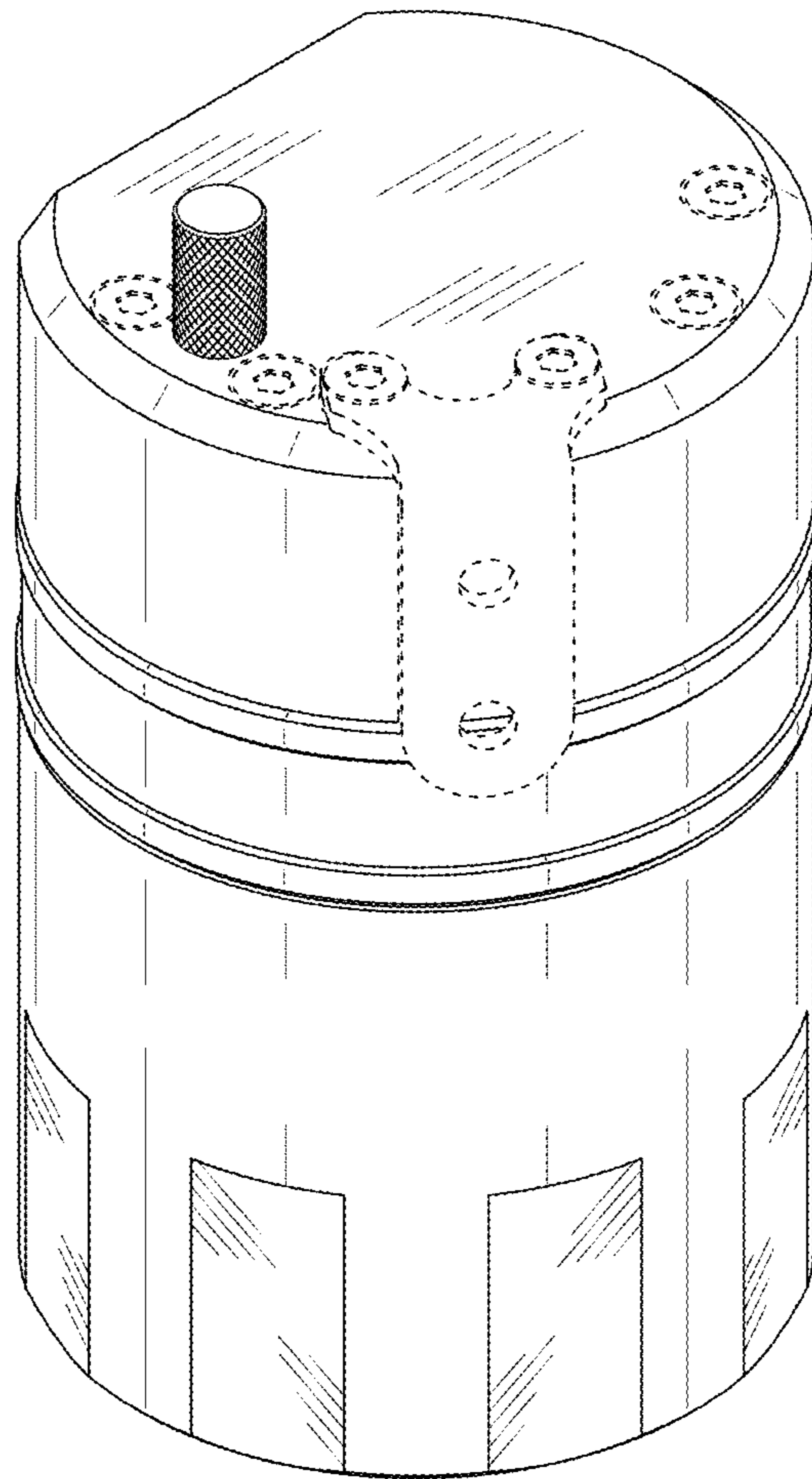

FIG. 9

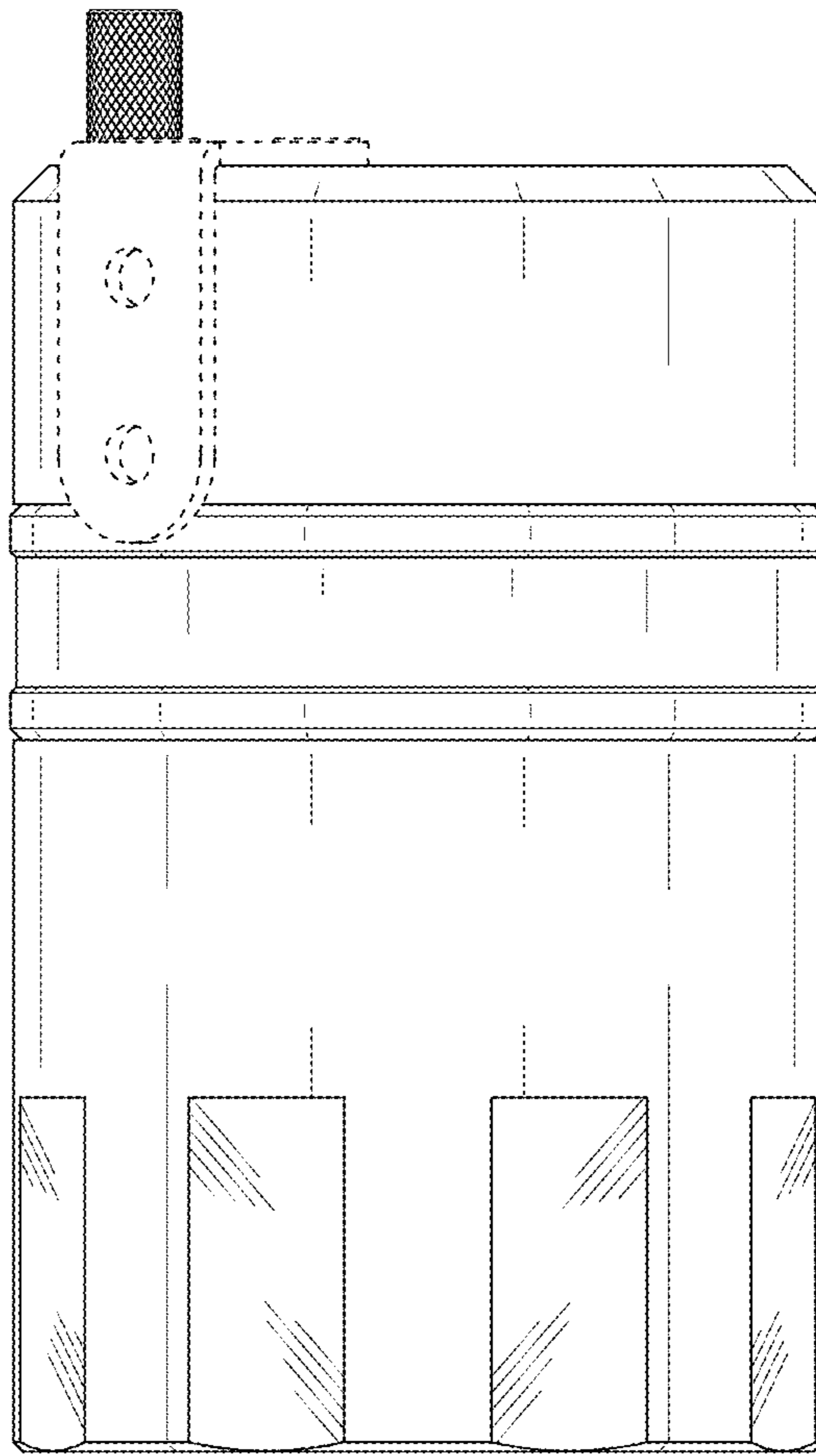

FIG. 10

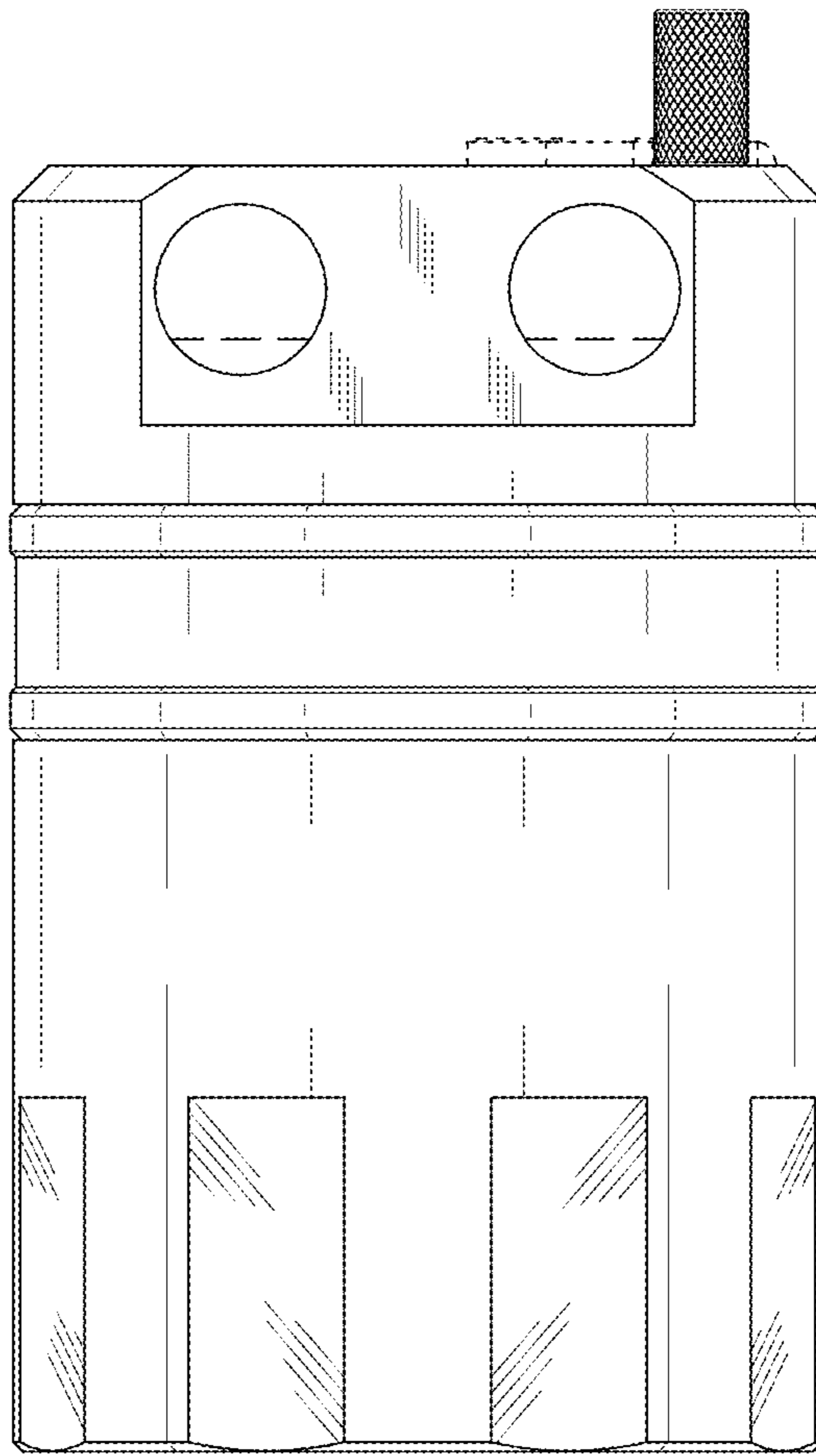

FIG. 11

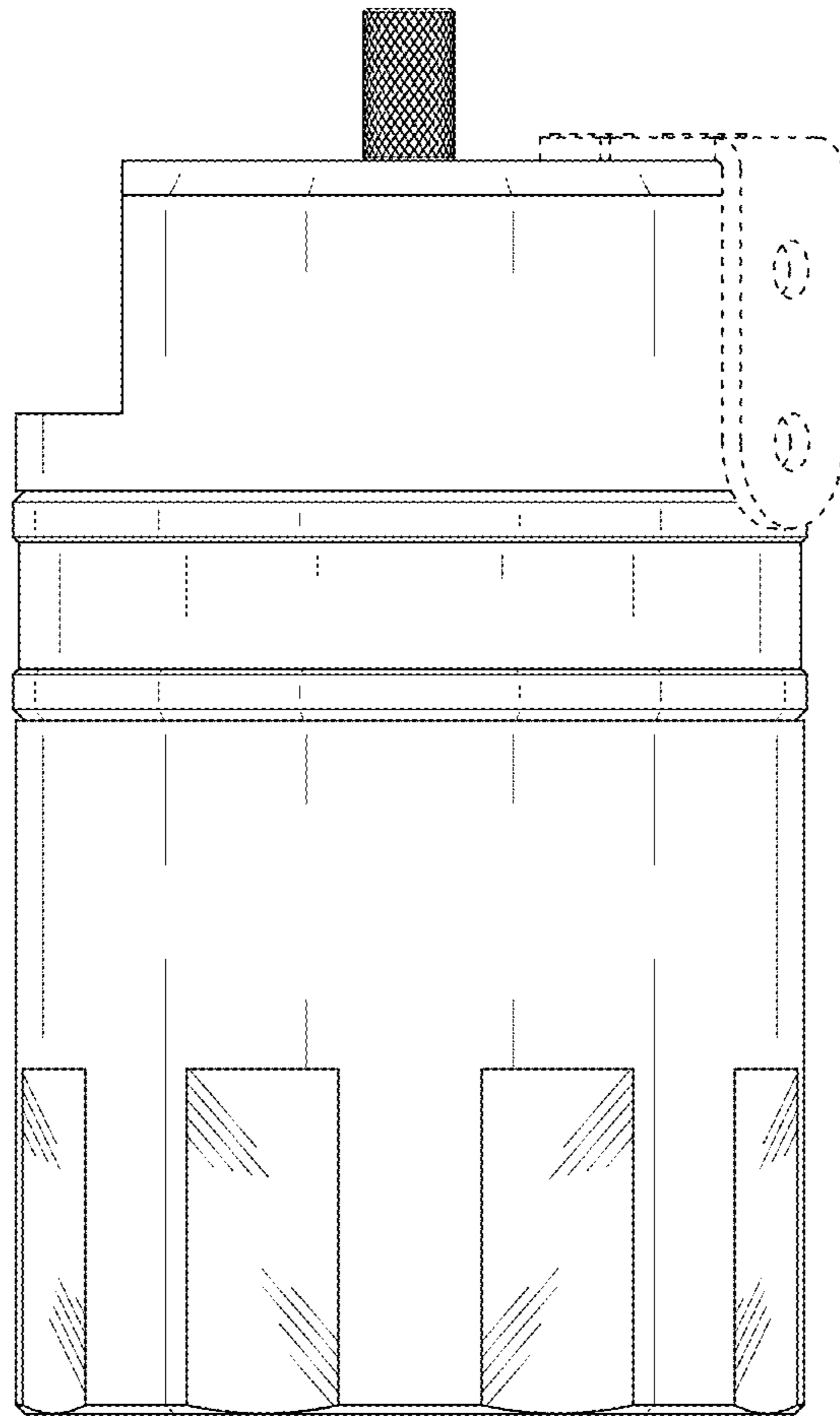

FIG. 12

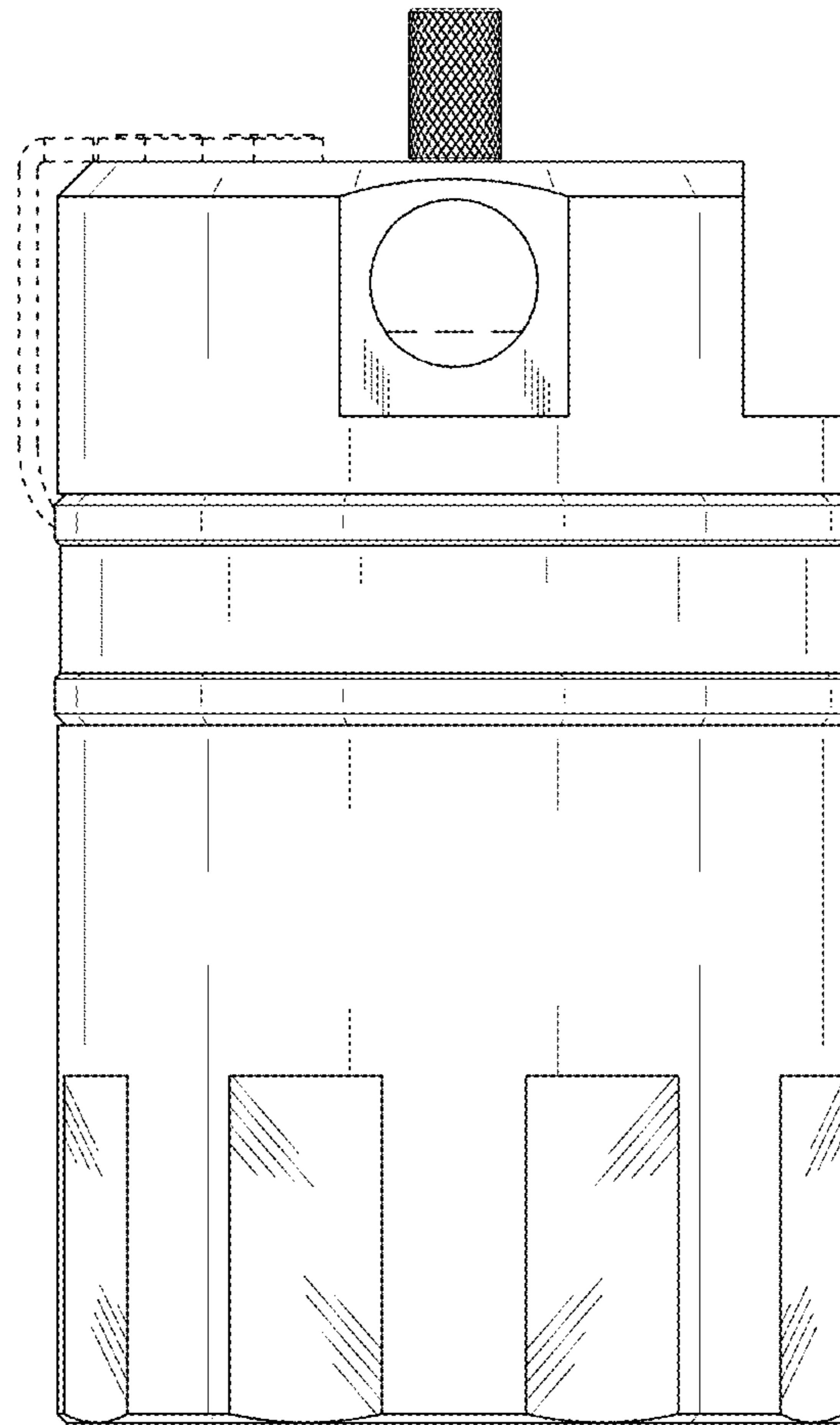

FIG. 13

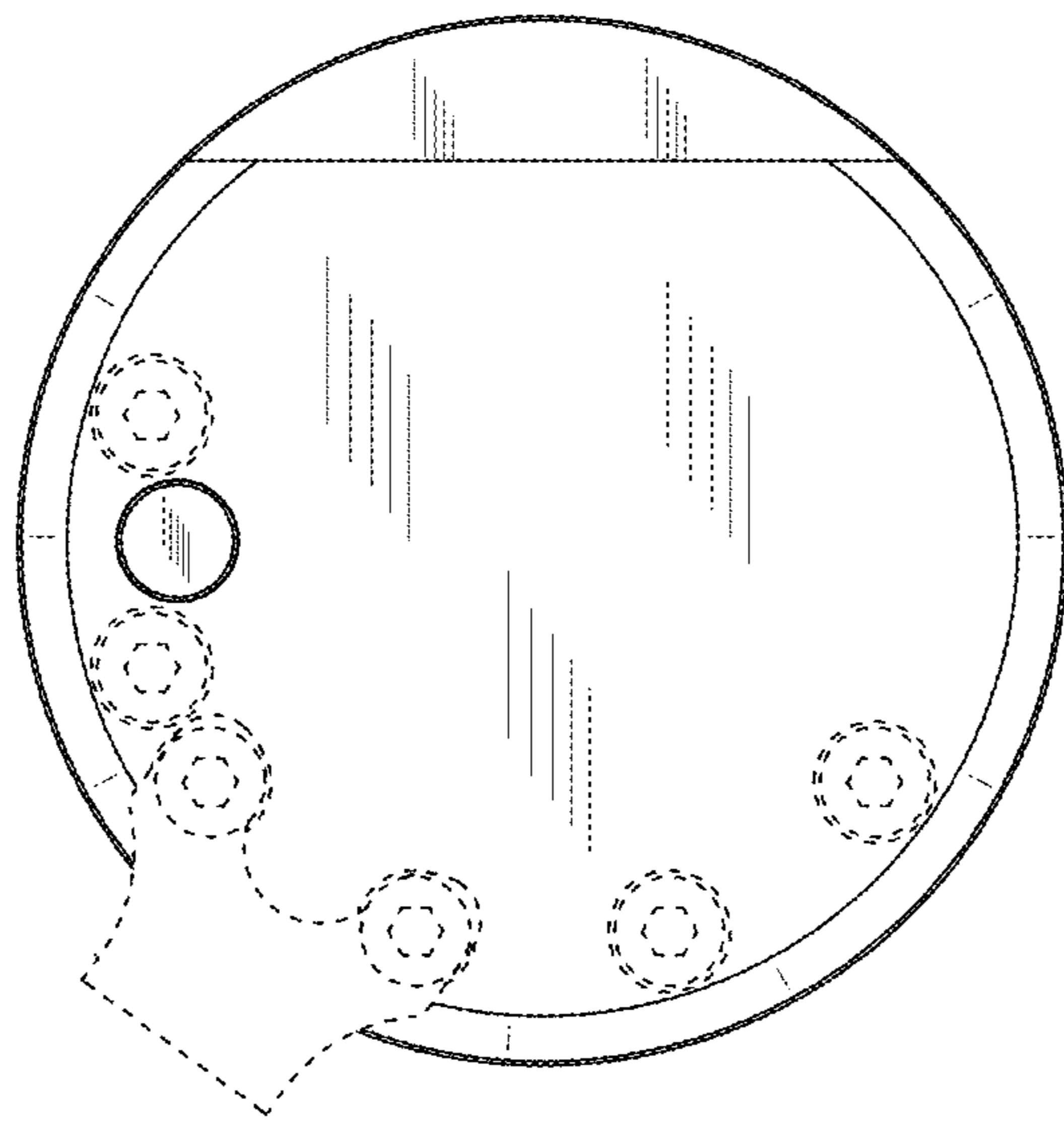

FIG. 14

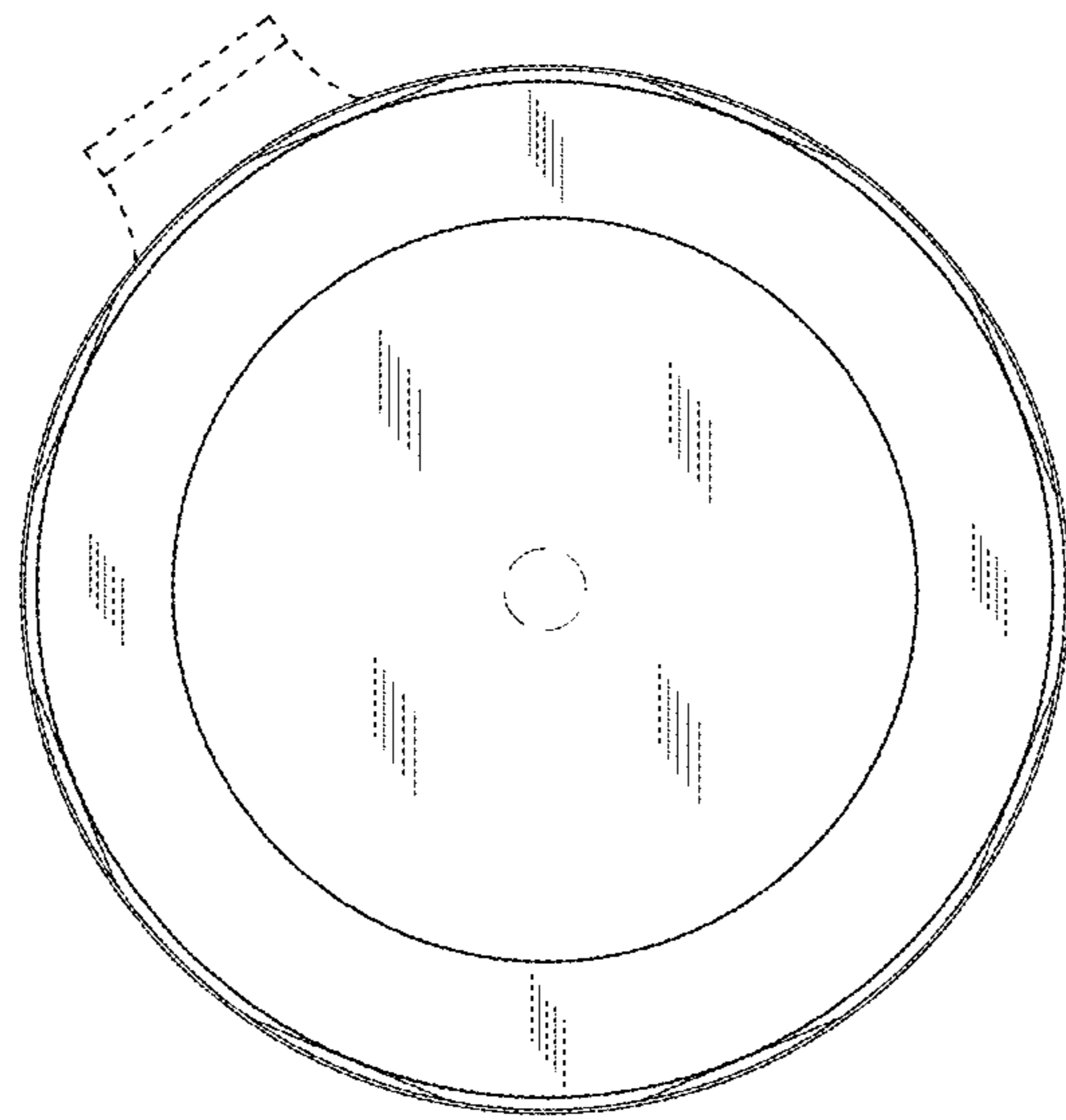

FIG. 15

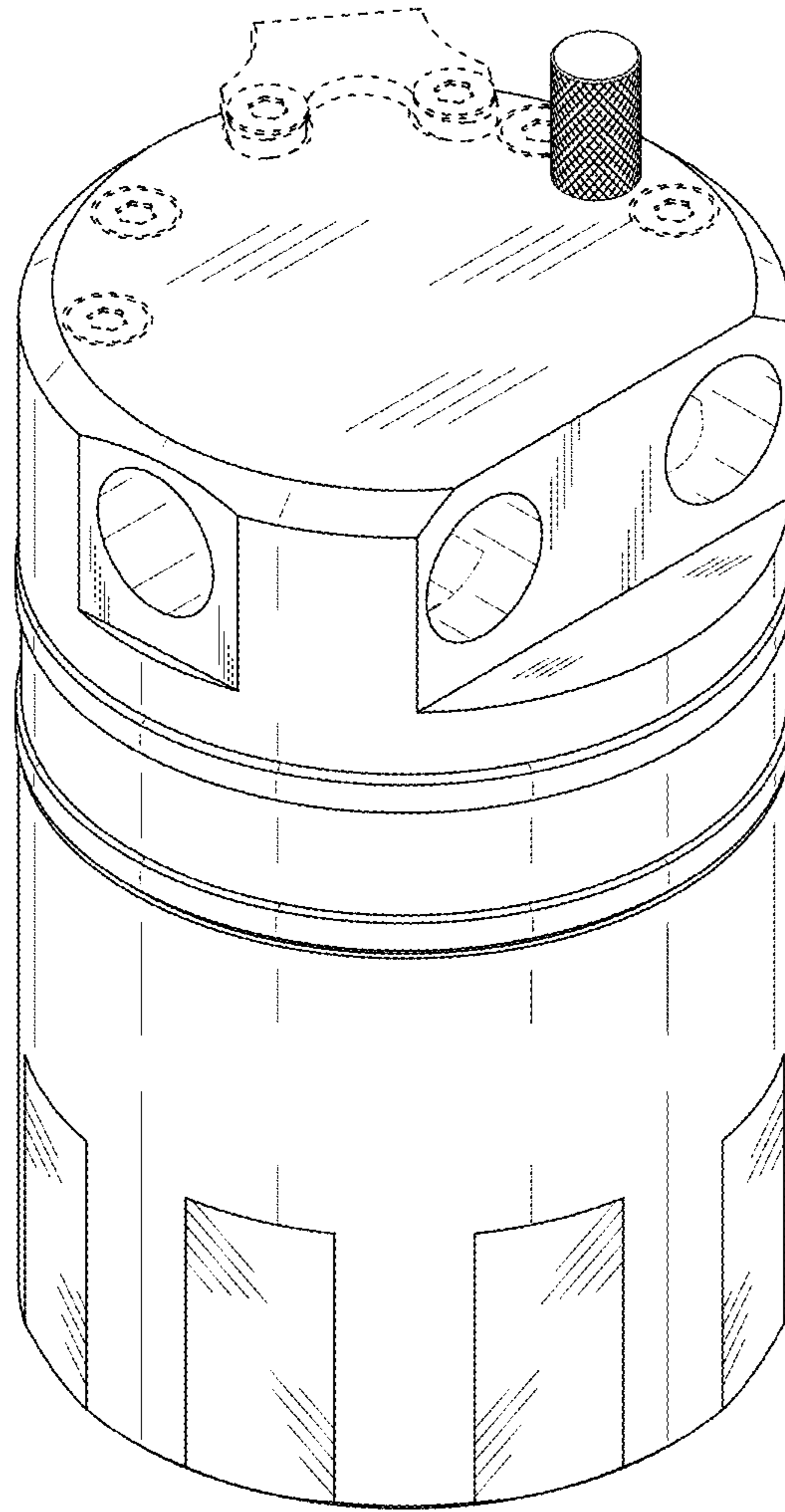

FIG. 16