



US00D870642S

(12) **United States Design Patent** (10) **Patent No.:** **US D870,642 S**
Adler et al. (45) **Date of Patent:** **** Dec. 24, 2019**

(54) **CARRIER**
(71) Applicant: **Thule Sweden AB**, Hillerstorp (SE)
(72) Inventors: **Jan Adler**, Skillingaryd (SE); **Jennifer Romans**, Fairfield, CT (US); **Johan Larsson**, Jönköping (SE)
(73) Assignee: **Thule Sweden AB**, Hillerstorp (SE)
(**) Term: **15 Years**
(21) Appl. No.: **29/657,133**
(22) Filed: **Jul. 19, 2018**
(51) **LOC (12) Cl.** **12-16**
(52) **U.S. Cl.**
USPC **D12/412**
(58) **Field of Classification Search**
USPC D12/412, 406, 413, 414, 414.1; D6/552;
D3/304-306
CPC B60R 9/04; B60R 9/048; B60R 9/045
See application file for complete search history.

D840,324 S * 2/2019 Adler D12/412
2014/0143990 A1 * 5/2014 Sautter B60R 9/052
24/68 CD
2017/0028929 A1 * 2/2017 Connors B60R 9/048
2017/0028930 A1 * 2/2017 Connors B60R 9/048

OTHER PUBLICATIONS

Yakima.com, "Jaylow," Yakima, dated Jun. 4, 2015. Available online at (<https://www.yakima.com/jaylow>).
Wayback Machine Internet Archive, "J-Loader," Maloneautoracks, dated Jul. 5, 2017. Available online at (<https://web.archive.org/web/20170705094747/https://maloneautoracks.com/J-Loader-TM.html>).

* cited by examiner

Primary Examiner — Katrina A Betton
(74) *Attorney, Agent, or Firm* — Sterne, Kessler, Goldstein & Fox P.L.L.C.

(57) **CLAIM**

The ornamental design for a carrier, as shown and described.

DESCRIPTION

FIG. 1 is a top front perspective view of a carrier showing the claimed design;
FIG. 2 is a bottom rear perspective view thereof;
FIG. 3 is a front view thereof;
FIG. 4 is a rear view thereof;
FIG. 5 is a left side view thereof;
FIG. 6 is a right side view thereof;
FIG. 7 is a top view thereof; and,
FIG. 8 is a bottom view thereof.
The dashed broken lines in the figures show portions of the carrier that form no part of the claimed design.
The dot-dash broken lines in the figures show boundaries that form no part of the claimed design.

(56) **References Cited**

U.S. PATENT DOCUMENTS

5,951,231 A * 9/1999 Allen B60P 3/1066
193/35 A
7,131,561 B2 * 11/2006 Humes B60R 9/08
224/319
D613,030 S * 4/2010 Baulier D1/127
D637,949 S * 5/2011 Farber D12/412
D665,725 S 8/2012 Laverack et al.
D665,726 S * 8/2012 Eriksson D12/412
9,067,522 B2 * 6/2015 Laverack B60R 9/045
D778,224 S * 2/2017 Eriksson D12/412
D813,786 S * 3/2018 Adler D12/412
D830,947 S 10/2018 Adler et al.

1 Claim, 8 Drawing Sheets

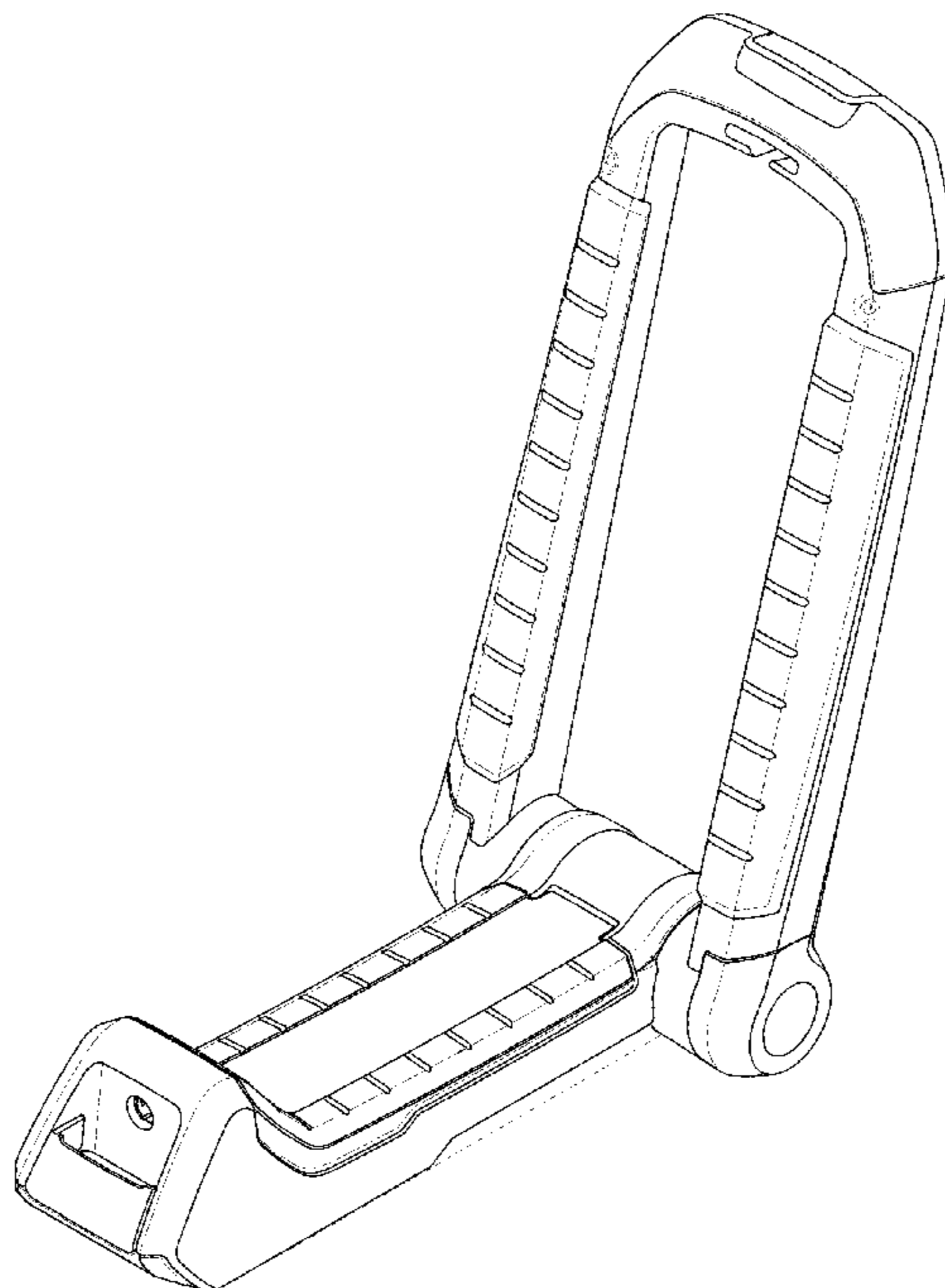

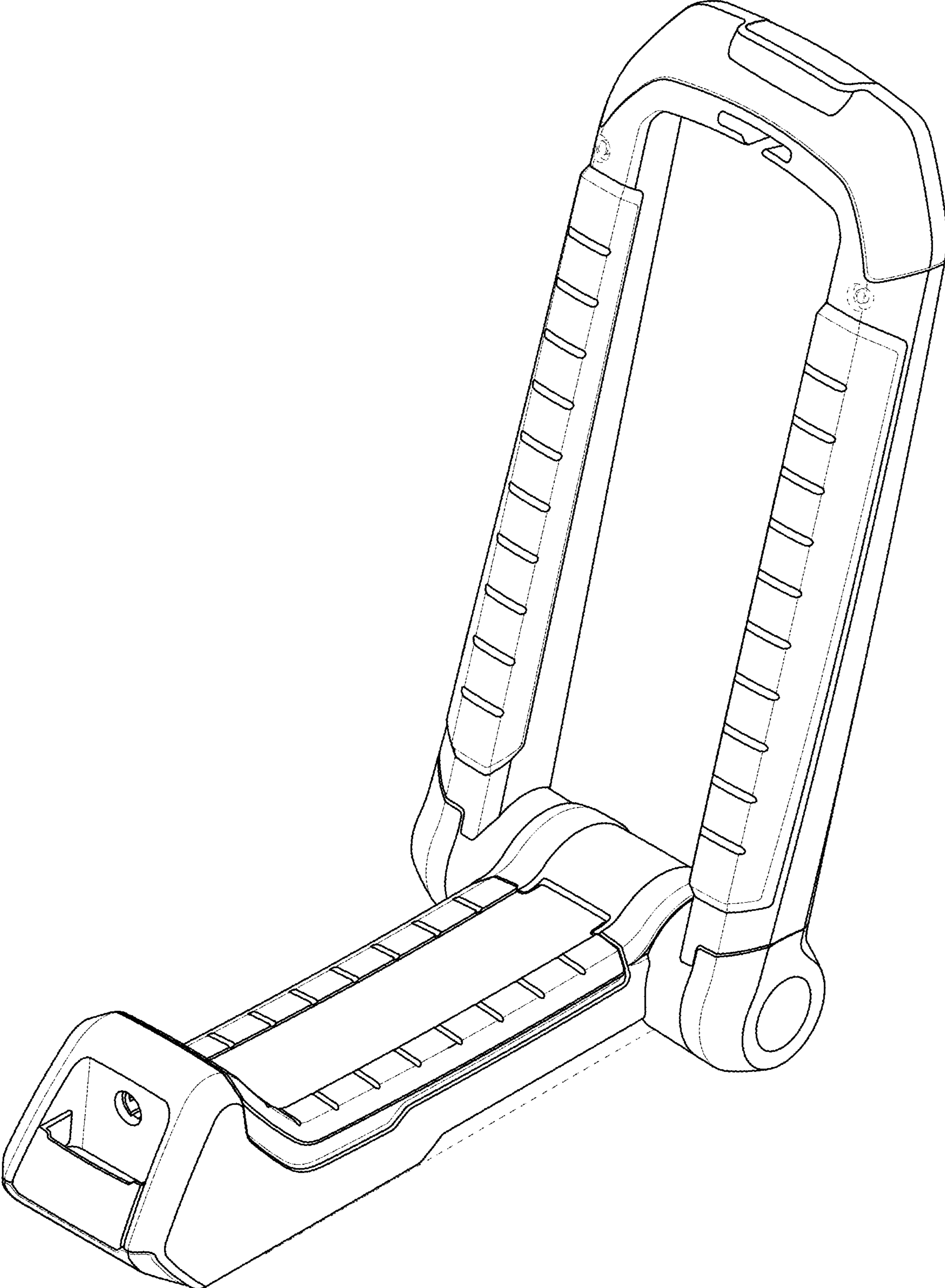

FIG. 1

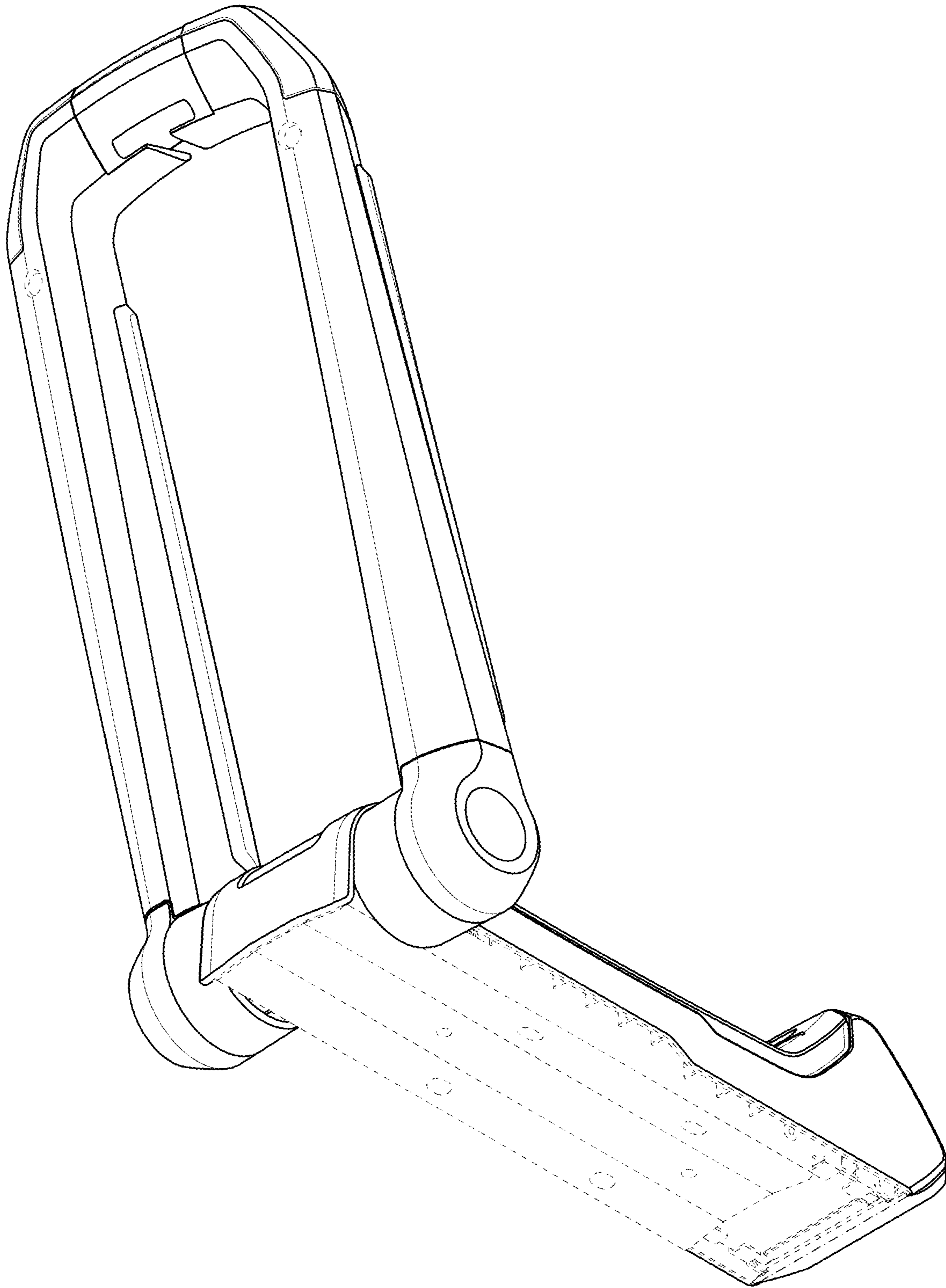

FIG. 2

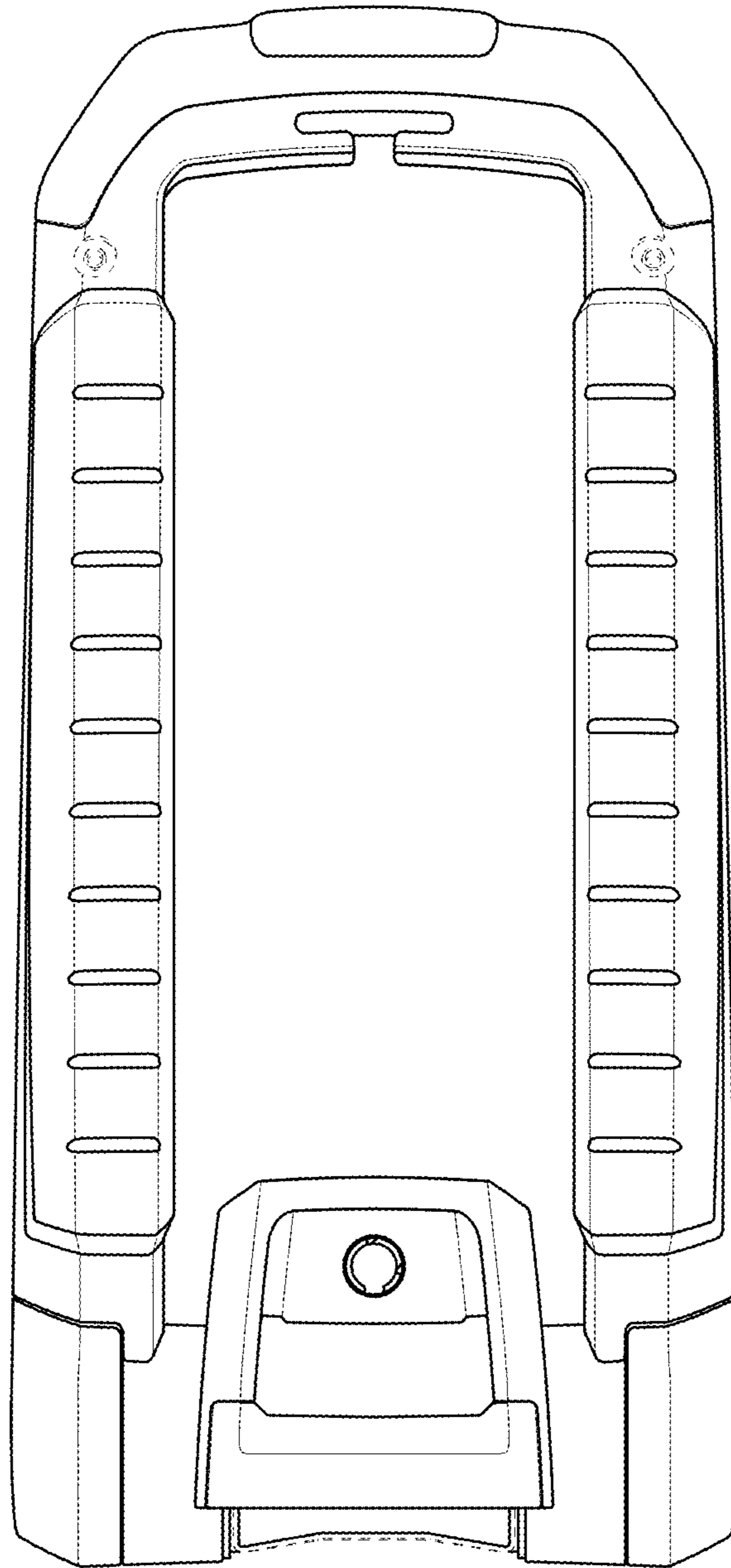

FIG. 3

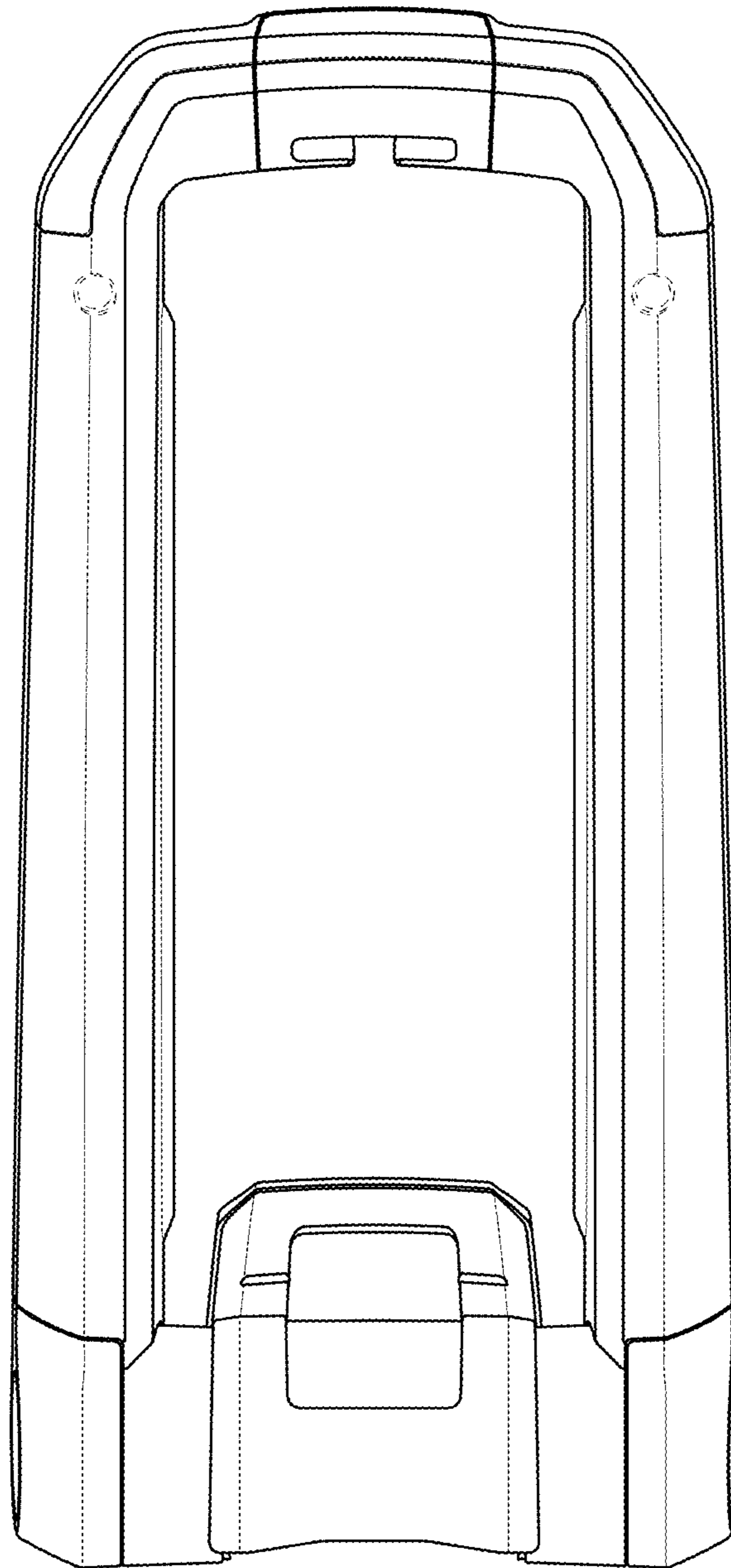

FIG.4

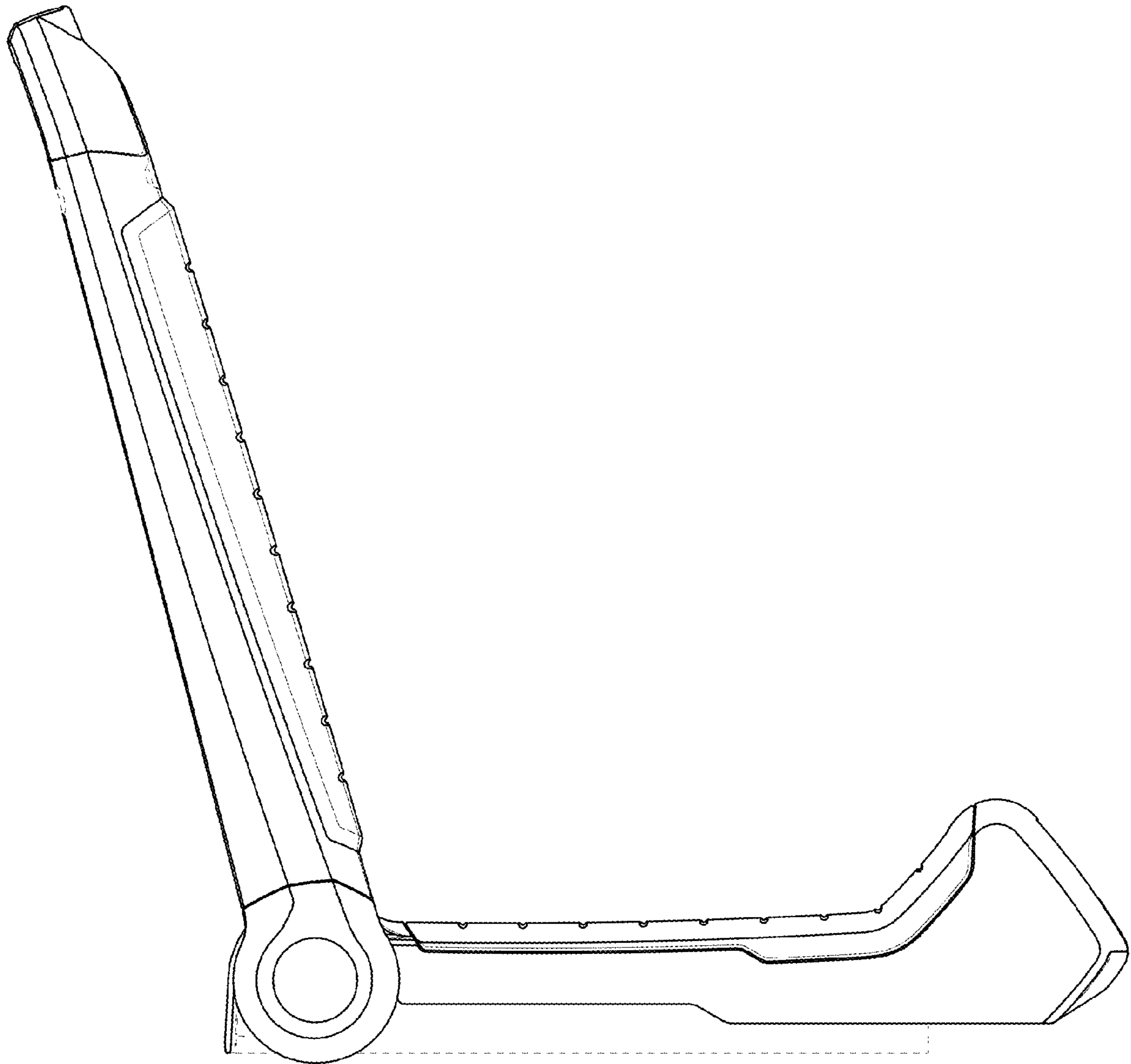

FIG. 5

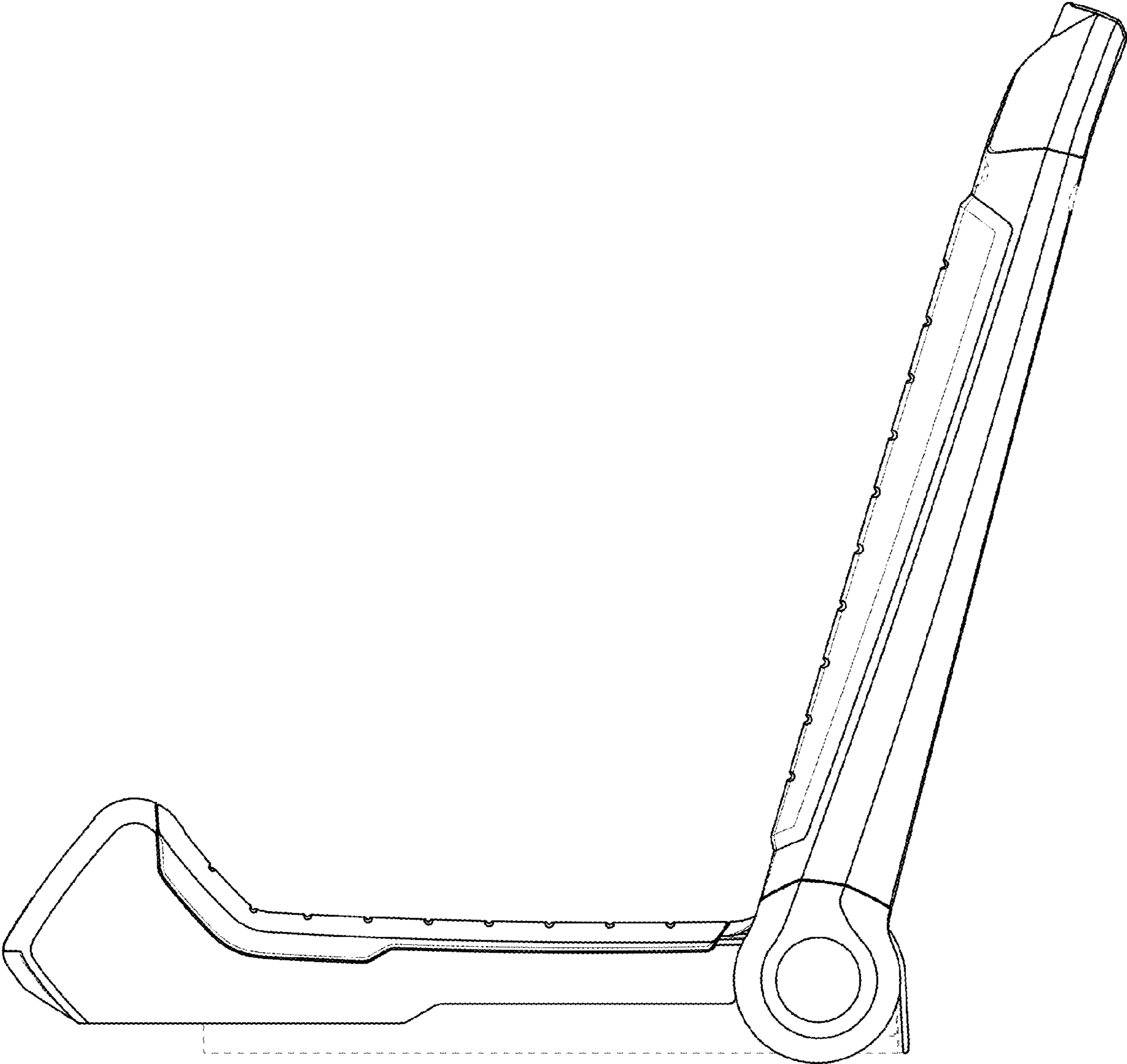

FIG. 6

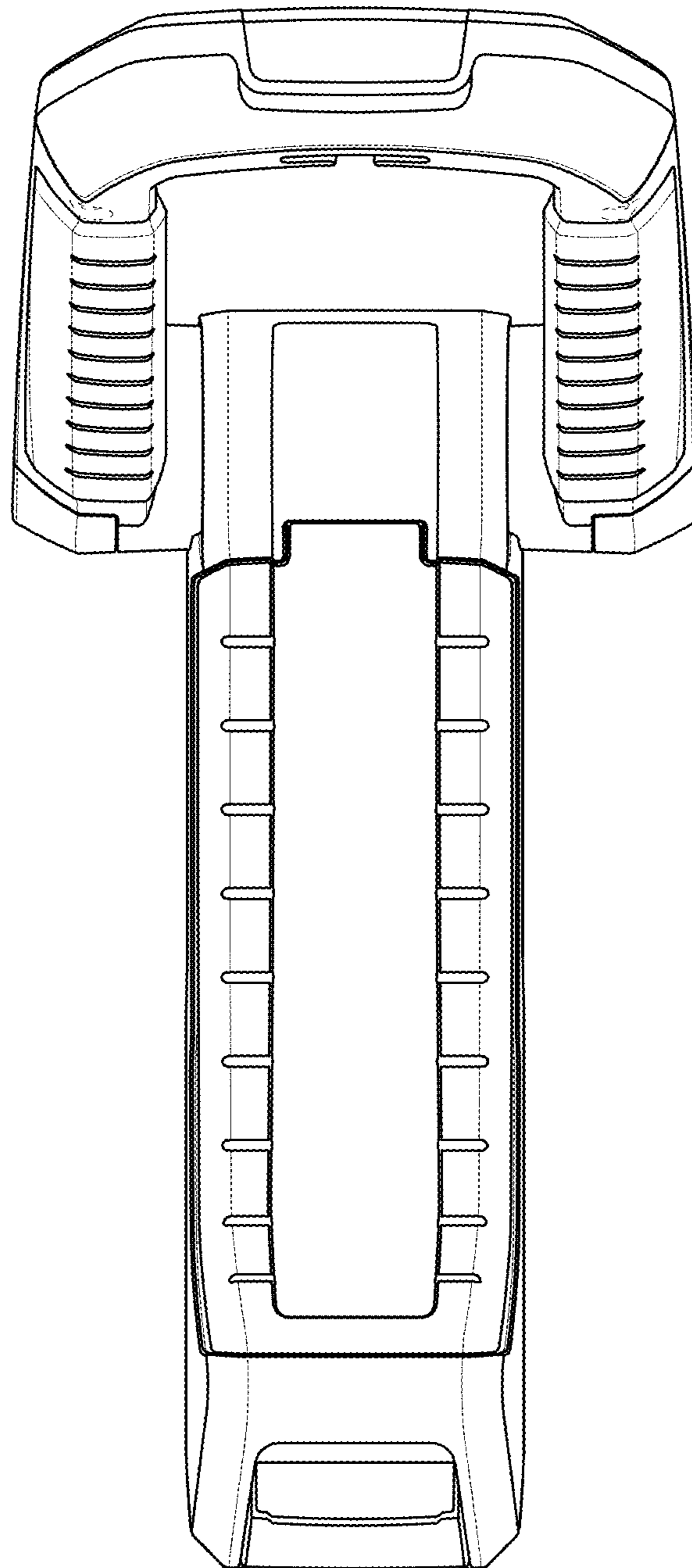

FIG. 7

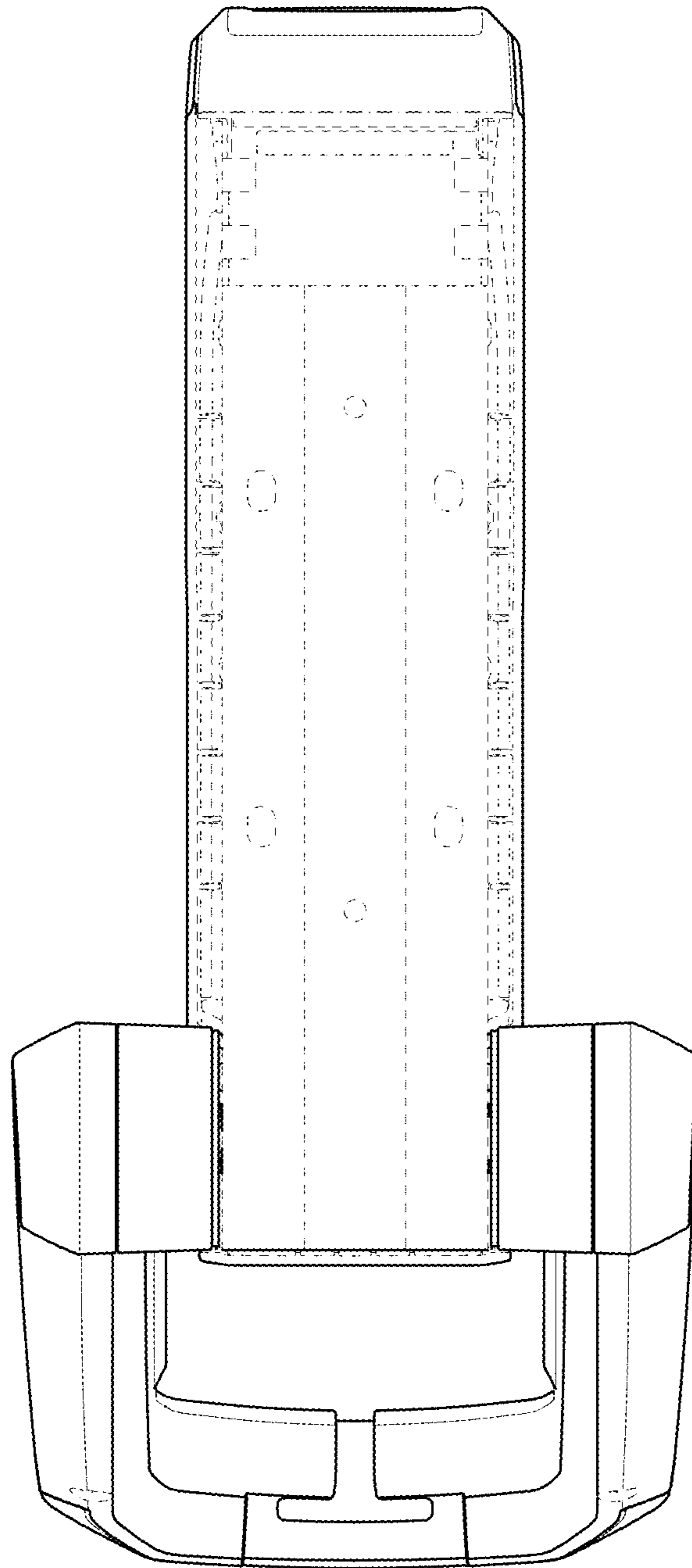

FIG. 8