



US00D870451S

(12) **United States Design Patent**  
**Birger**

(10) **Patent No.:** **US D870,451 S**

(45) **Date of Patent:** **\*\* Dec. 24, 2019**

(54) **CASE**

(71) Applicant: **GN Audio A/S**, Ballerup (DK)

(72) Inventor: **Johan Birger**, Ballerup (DK)

(73) Assignee: **GN AUDIO A/S** (DK)

(\*\*) Term: **15 Years**

(21) Appl. No.: **29/639,628**

(22) Filed: **Mar. 7, 2018**

**Related U.S. Application Data**

(62) Division of application No. 29/589,943, filed on Jan. 5, 2017, now Pat. No. Des. 832,240.

**Foreign Application Priority Data**

- Jul. 7, 2016 (EM) ..... 003297720-0001
- Jul. 7, 2016 (EM) ..... 003297720-0002
- Jul. 7, 2016 (EM) ..... 003297720-0003
- Jul. 7, 2016 (EM) ..... 003297720-0004
- Jul. 7, 2016 (EM) ..... 003297720-0005
- Jul. 7, 2016 (EM) ..... 003297720-0006
- Jul. 7, 2016 (EM) ..... 003297720-0007

(51) **LOC (12) Cl.** ..... **03-01**

(52) **U.S. Cl.**  
USPC ..... **D3/201; D14/223**

(58) **Field of Classification Search**  
USPC ..... D14/205, 223; D3/201, 218, 295, 423, D3/294; D9/721, 423, 415, 432, 426, D9/420; D19/75, 73; D28/78, 83; 132/301, 295; 206/702, 751, 495, 566, 206/573, 538, 38, 320; 220/4.22; D24/174; 128/866; 181/129, 130, 135; 381/380, 381, 328, 323; D13/168, 184; 455/90.3, 575.1, 569.1

CPC ..... H04R 25/00; H04R 1/10; H04R 1/1066; H04R 1/1016; H04R 25/02; H04R 25/652; B65D 5/00; B65D 43/02; B65D 25/10; B65D 43/16; A45C 11/00; A45D 33/006

See application file for complete search history.

(56) **References Cited**

U.S. PATENT DOCUMENTS

1,906,111	A	4/1933	Shields	
D141,071	S	5/1945	Hechler	
4,542,822	A	9/1985	Kennedy	
D281,033	S	10/1985	Mohri	
4,732,269	A	3/1988	Roy	
D313,753	S *	1/1991	Nagasaka	..... D9/415
5,146,051	A	9/1992	Hermann	
D333,560	S *	3/1993	Miyashita	..... D3/218
D333,917	S *	3/1993	Daido	..... D3/218
D388,093	S	12/1997	Frengley	
5,782,371	A *	7/1998	Baerenwald	..... B65D 43/168 16/DIG. 13

(Continued)

*Primary Examiner* — Paula Allen Greene  
(74) *Attorney, Agent, or Firm* — Hamre, Schumann, Mueller & Larson, P.C.

(57) **CLAIM**

The ornamental design for a case, as shown and described.

**DESCRIPTION**

FIG. 1 is a perspective view of a case, with the case opened. FIG. 2 is a front planar view of FIG. 1 thereof. FIG. 3 is a back planar view of FIG. 1 thereof. FIG. 4 is a left side planar view of FIG. 1 thereof. FIG. 5 is a right side planar view of FIG. 1 thereof. FIG. 6 is a top planar view of FIG. 1 thereof; and, FIG. 7 is a bottom planar view of FIG. 1 thereof. The features shown in broken lines depict environmental subject matter only and form no part of the claimed design.

**1 Claim, 7 Drawing Sheets**

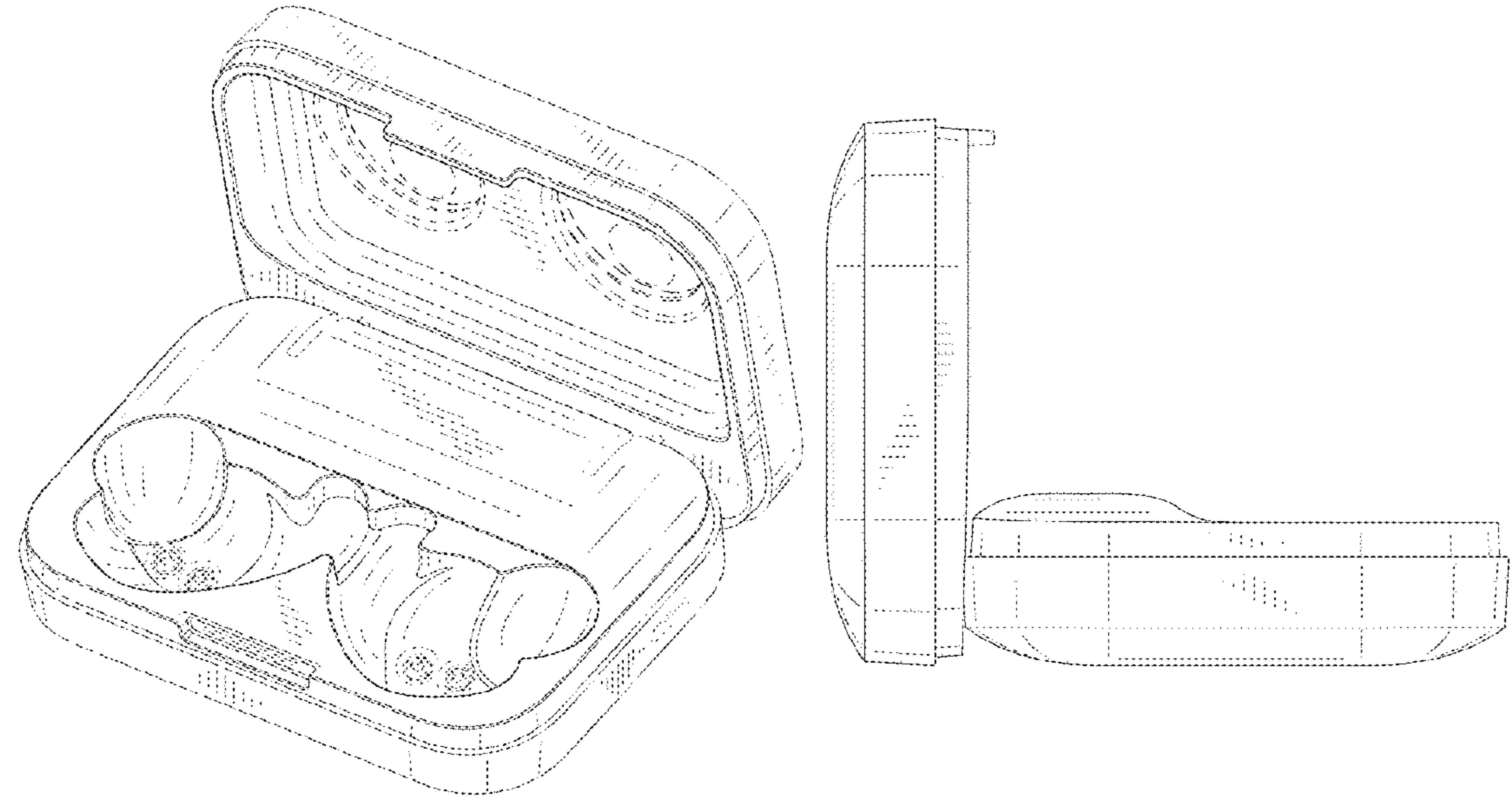

(56)

References Cited

U.S. PATENT DOCUMENTS

D399,001 S 9/1998 Yabe  
 5,887,720 A 3/1999 Lin  
 D419,564 S 1/2000 McDonald  
 6,122,388 A 9/2000 Feldman  
 D449,165 S \* 10/2001 van der Hulst ..... D3/294  
 D469,607 S \* 2/2003 Wolff ..... D3/294  
 D478,991 S 8/2003 Dyer  
 D479,016 S \* 8/2003 Sgariboldi ..... D28/78  
 6,690,807 B1 2/2004 Meyer  
 D506,744 S \* 6/2005 Andre ..... D14/205  
 6,945,988 B1 9/2005 Jones  
 D529,288 S \* 10/2006 Ham ..... D3/294  
 D531,025 S 10/2006 Tanner  
 D551,216 S \* 9/2007 Wei ..... D14/223  
 D585,429 S 1/2009 Dean  
 D604,501 S \* 11/2009 Lee ..... D3/201  
 D612,094 S \* 3/2010 Bellamah ..... D27/189  
 D618,219 S 6/2010 Burgett  
 D621,256 S \* 8/2010 Andre ..... D9/432  
 D622,265 S 8/2010 Rye  
 D622,705 S 8/2010 Fahrenedorff  
 D628,990 S 12/2010 Pedersen  
 7,949,127 B2 5/2011 Pedersen  
 D640,670 S 6/2011 Rye  
 7,965,855 B1 6/2011 Ham  
 D641,008 S 7/2011 Lee  
 D645,458 S 9/2011 Silvestri  
 D655,693 S 3/2012 Silvestri  
 D664,124 S 7/2012 Smith  
 D667,301 S \* 9/2012 Jones ..... D9/456  
 8,311,253 B2 11/2012 Silvestri  
 D686,065 S \* 7/2013 Kuo ..... D9/432  
 D694,182 S \* 11/2013 Lee ..... D13/108  
 D699,215 S 2/2014 Koch  
 D705,532 S \* 5/2014 Kolton ..... D3/201

D706,643 S \* 6/2014 Akana ..... D9/432  
 D709,758 S \* 7/2014 Burdock-Latter ..... D9/418  
 D712,279 S 9/2014 Akana  
 D716,770 S 11/2014 Bonahoom  
 8,910,781 B2 \* 12/2014 Pipes ..... B65B 7/28  
 206/236  
 D722,264 S \* 2/2015 Saideh ..... D9/418  
 8,965,030 B2 2/2015 Aasw  
 D728,532 S 5/2015 Kurtz  
 D742,362 S 11/2015 Bonahoom  
 D743,948 S 11/2015 Crawford  
 D744,456 S 12/2015 Pedersen  
 9,445,631 B1 9/2016 Patel  
 D772,572 S \* 11/2016 Palmborg ..... D3/201  
 D773,440 S 12/2016 Pedersen  
 D773,441 S 12/2016 Pedersen  
 D774,021 S 12/2016 Pedersen  
 D777,149 S 1/2017 Bonahoom  
 D778,156 S \* 2/2017 Follett ..... D9/432  
 D786,834 S 5/2017 Samrelius  
 D794,955 S \* 8/2017 Paterson ..... D3/201  
 D799,316 S 10/2017 Thain  
 D801,312 S \* 10/2017 Birger ..... H04R 1/1016  
 D14/223  
 D811,745 S \* 3/2018 Davi ..... D3/294  
 D832,240 S \* 10/2018 Birger ..... D14/223  
 D838,480 S \* 1/2019 Son ..... D3/294  
 D839,583 S \* 2/2019 Cao ..... D3/201  
 D844,969 S \* 4/2019 Xiao ..... D3/201  
 D845,932 S \* 4/2019 Lu ..... D14/223  
 2007/0256946 A1 \* 11/2007 Godshaw ..... B65D 25/10  
 206/320  
 2007/0272686 A1 \* 11/2007 Yu ..... A45C 11/00  
 220/4.02  
 2011/0186579 A1 \* 8/2011 Bailey ..... B65D 25/54  
 220/495.01

\* cited by examiner



FIG. 1

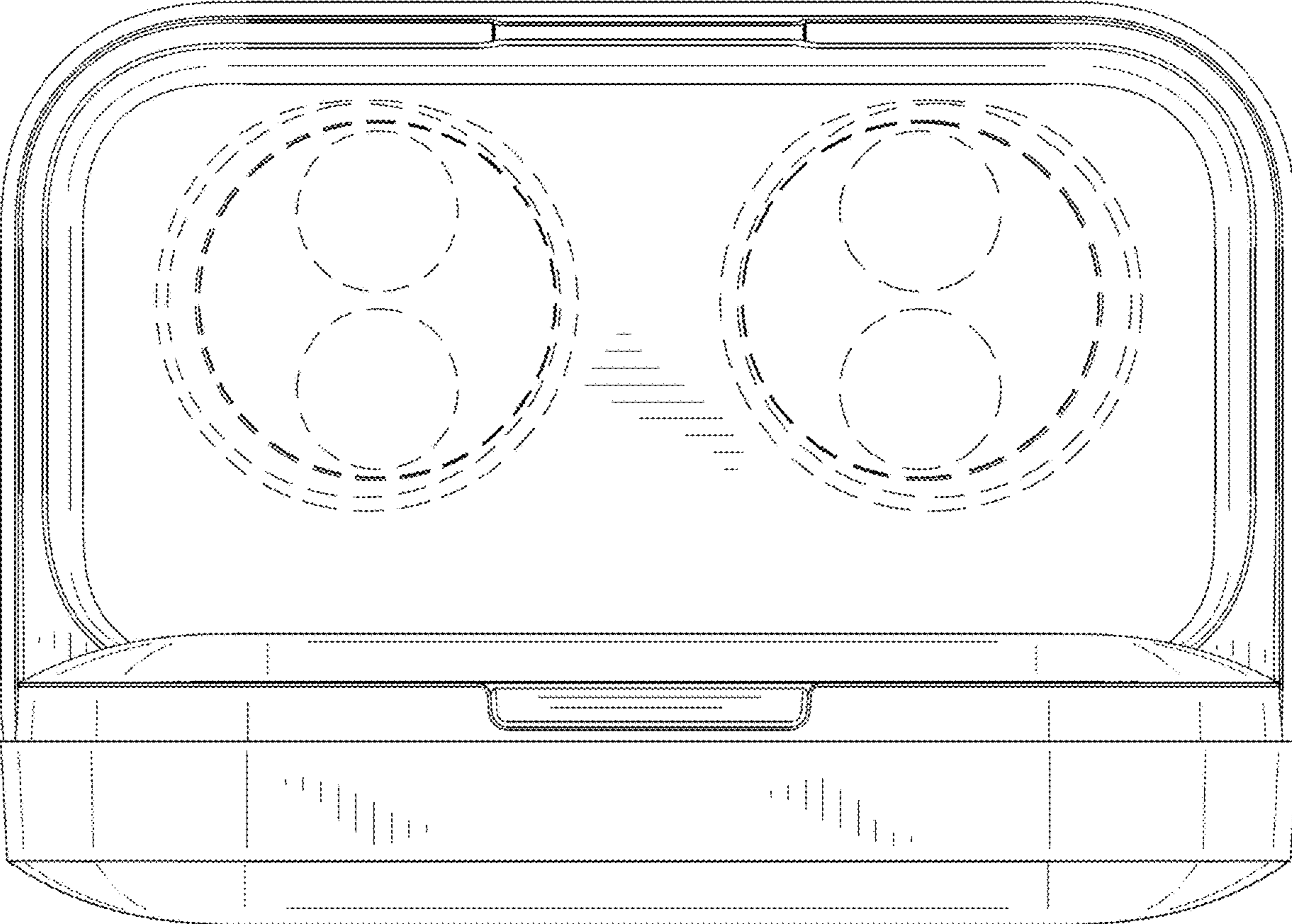
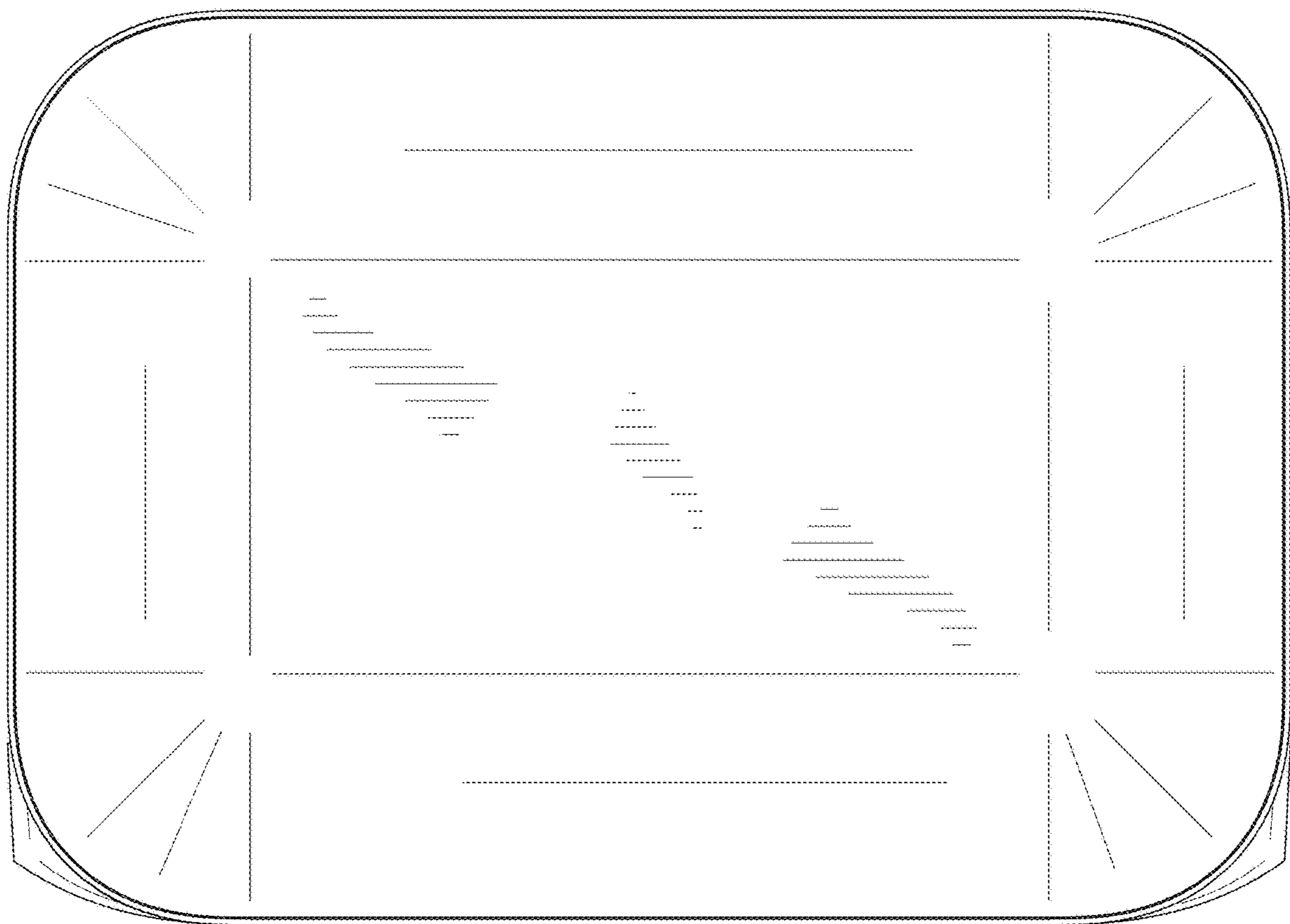
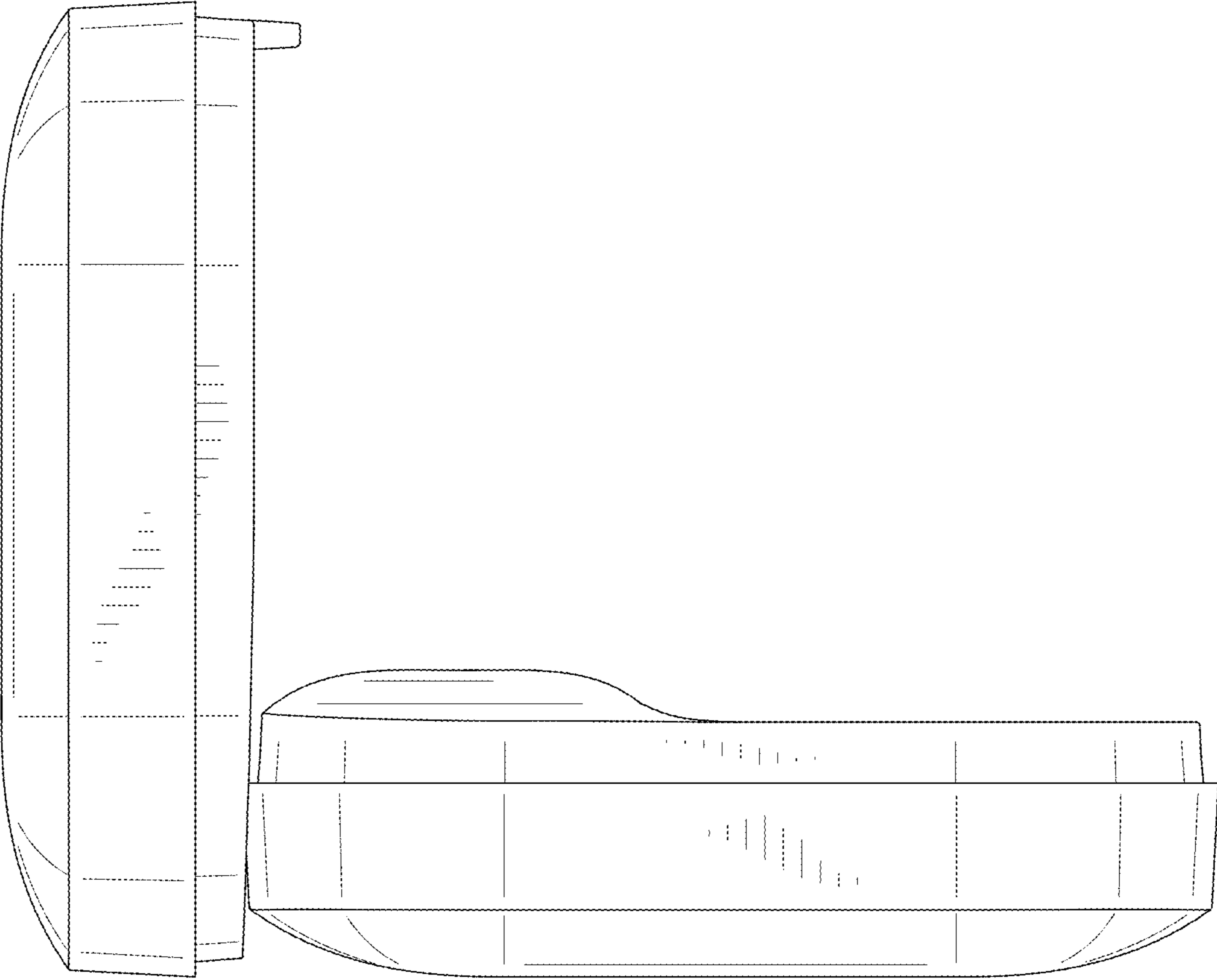

FIG. 2



**FIG. 3**



**FIG. 4**

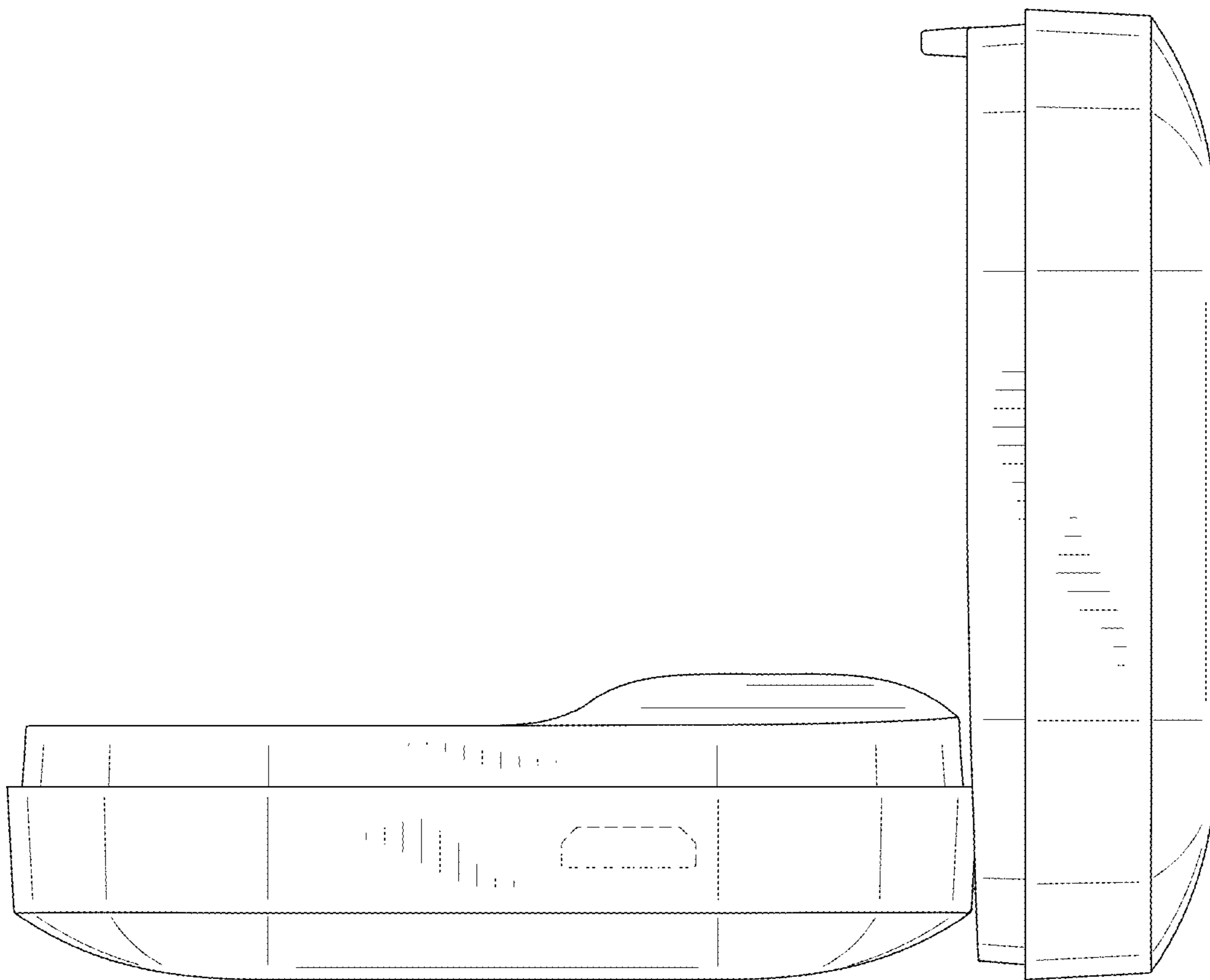

**FIG. 5**

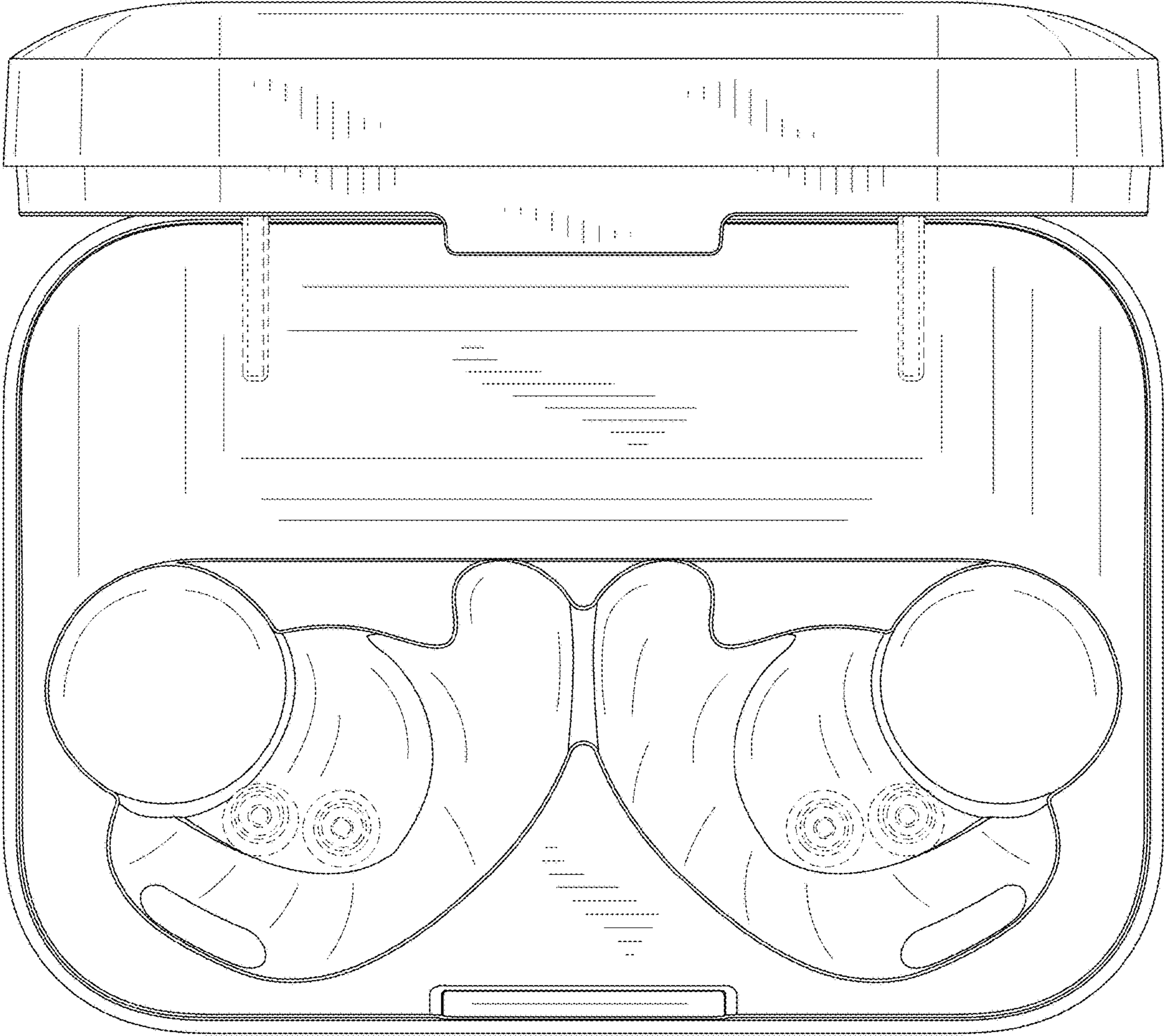

FIG. 6



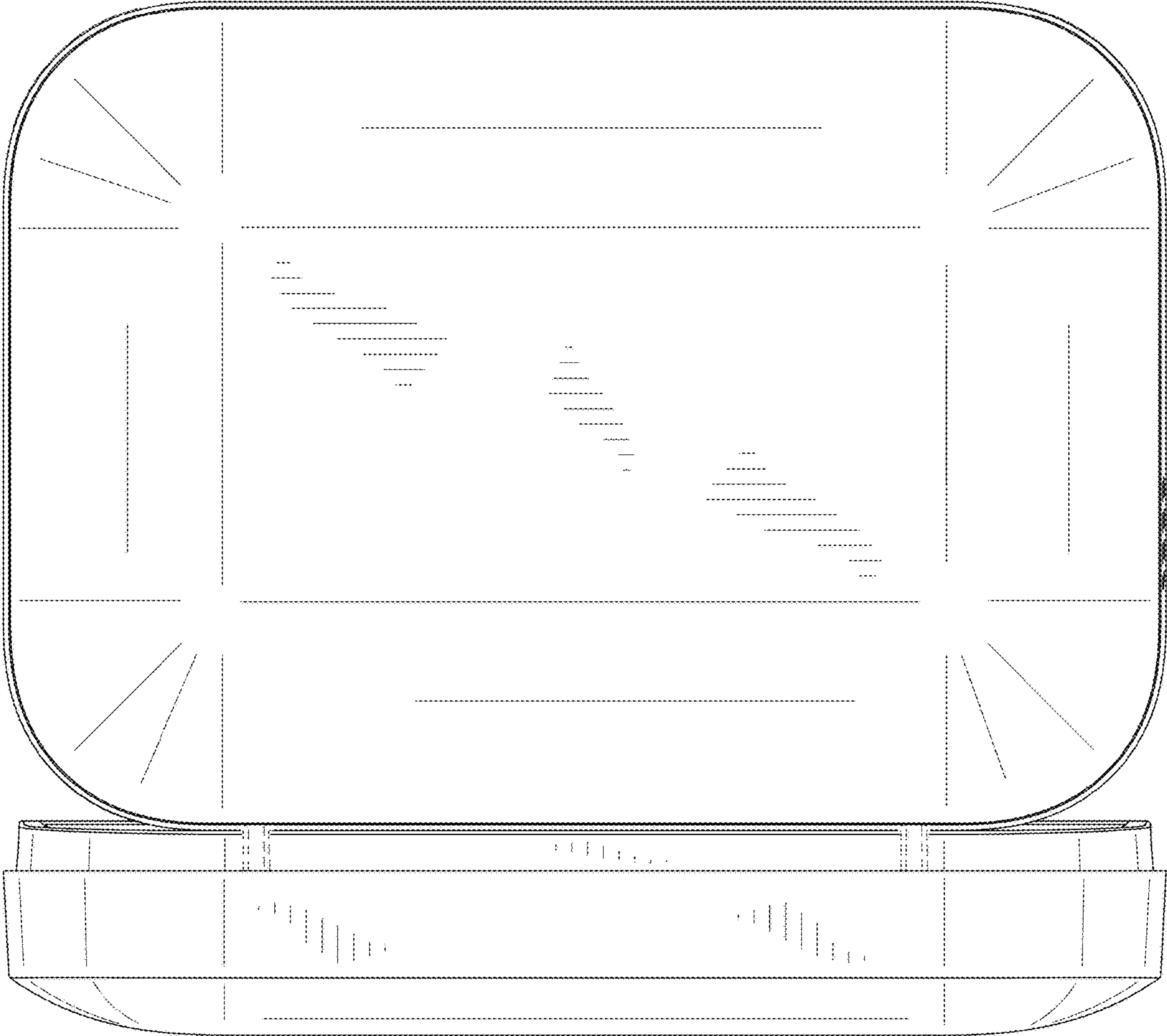

FIG. 7