



US00D870282S

(12) **United States Design Patent** (10) **Patent No.:** **US D870,282 S**
Adams (45) **Date of Patent:** **** *Dec. 17, 2019**

(54) **SINGLE STRAND BI-DIRECTIONAL BARB SUTURE WITH COATING SHIELD**

- (71) Applicant: **Jason P. Adams**, Farmington, NM (US)
- (72) Inventor: **Jason P. Adams**, Farmington, NM (US)
- (*) Notice: This patent is subject to a terminal disclaimer.
- (**) Term: **15 Years**
- (21) Appl. No.: **29/623,742**
- (22) Filed: **Oct. 26, 2017**

Related U.S. Application Data

- (63) Continuation-in-part of application No. 15/096,496, filed on Apr. 12, 2016, now abandoned.
- (51) **LOC (12) Cl.** **24-02**
- (52) **U.S. Cl.**
USPC **D24/145**
- (58) **Field of Classification Search**
USPC D24/133, 155, 169, 145, 146, 147, 148
(Continued)

(56) **References Cited**

U.S. PATENT DOCUMENTS

- 3,720,055 A 3/1973 De Mestral et al.
 - 8,062,363 B2 11/2011 Hirpara et al.
- (Continued)

FOREIGN PATENT DOCUMENTS

- CA 2777345 A1 11/2012
 - EP 2338421 B1 11/2012
- (Continued)

OTHER PUBLICATIONS

John R. Fowler, MD, Tiffany A. Perkins, BS, Bettina A. Buttaro, PhD, and Allan L. Truant, PhD, Clin Ortho Relat Res. Bacteria

Adhere Less to Barbed Monofilament Than Braided Sutures in a Contaminated Wound Model, Feb. 2013; 471(2): 665-671.

(Continued)

Primary Examiner — Cathron C Brooks

Assistant Examiner — Samantha Q Lawrence

(74) *Attorney, Agent, or Firm* — Pate Baird, PLLC

(57) **CLAIM**

The ornamental design for a double-shield, bi-directional-barb, single strand suture, as shown and described.

DESCRIPTION

FIG. 1 is a side elevation view of a single strand suture with barb in accordance with the invention, showing the single strand suture with barb in a first condition of use wherein the strand is shown in a coated condition;

FIG. 2 is an enlarged, partial side elevation of a portion of the single strand bi-directional barb suture with coating shield taken from FIG. 1;

FIG. 3 is an enlarged partial perspective view of top-most portion of the single strand bi-directional suture with coating shield as shown in FIG. 1;

FIG. 4 is a cross-section view thereof, showing the single strand suture with barb taken along line 4-4 of FIG. 2; and, FIG. 5 is another cross-section view thereof, showing the single strand suture with barb in a second condition of use wherein the strand is in a non-coated condition.

The single strand suture with barb is shown with a symbolic break in its length, i.e., FIG. 1. The appearance of any portion of the article between the break lines forms no part of the claimed design.

The single strand suture with barb contains a repeating pattern of barbs, wherein the pattern of barbs repeats along the length of the suture filaments forming a single-stranded suture. Before and during use, the single-stranded suture contains coating. Once the single strand suture with barb is installed, the coating on the strand dissolves.

1 Claim, 2 Drawing Sheets

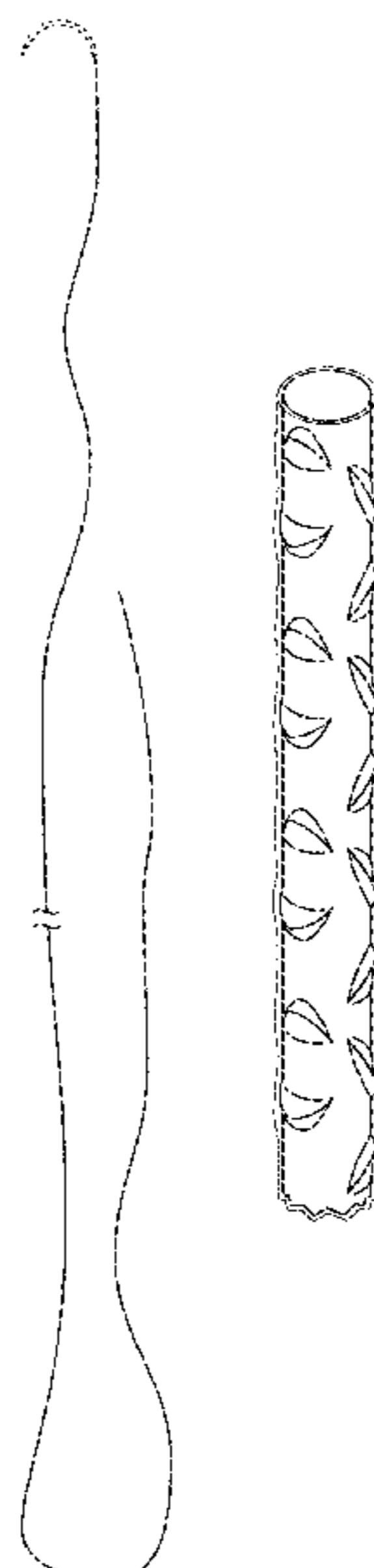

(58) **Field of Classification Search**

CPC A61B 17/06166; A61B 17/0401; A61B
2017/00526; A61B 2017/06176; A61B
17/06066; A61B 17/04; A61B 2017/0417;
A61B 2017/0608; A61B 17/0469; A61B
17/0483; A61B 17/0485; A61B 17/062;
A61B 17/0046; A61F 2002/075; B21G
1/08

See application file for complete search history.

(56) **References Cited**

U.S. PATENT DOCUMENTS

8,353,931 B2 1/2013 Stopek et al.
8,562,644 B2 10/2013 Yuan et al.
9,125,647 B2* 9/2015 Goraltchouk A61B 17/06166
9,248,580 B2* 2/2016 Leung B26D 3/08
2010/0298878 A1* 11/2010 Leung A61B 17/0401
606/232
2012/0130406 A1* 5/2012 Odermatt A61B 17/06166
606/151
2012/0277793 A1* 11/2012 Marczyk A61B 17/06166
606/228
2013/0066369 A1 3/2013 Collier et al.
2013/0165971 A1 6/2013 Leung et al.
2014/0213966 A1* 7/2014 Ostapoff A61B 17/06166
604/93.01
2015/0272720 A1* 10/2015 Marks A61B 17/00008
623/13.2
2016/0278769 A1* 9/2016 Kim D02J 3/10
2017/0189016 A1* 7/2017 Gross A61B 17/06166

2017/0281160 A1* 10/2017 Lin A61B 17/06166
2017/0319203 A1* 11/2017 Cohen A61B 17/06166
2018/0116648 A1* 5/2018 Kim A61B 17/06109
2018/0125472 A1* 5/2018 Dreyfuss A61B 17/0401
2018/0140291 A1* 5/2018 Dreyfuss A61B 17/0401
2018/0177505 A1* 6/2018 Chu A61B 17/06166

FOREIGN PATENT DOCUMENTS

EP 2447040 A3 12/2013
JP 61171998 2/1986

OTHER PUBLICATIONS

James A. Greenberg, MD, US National Library of Medicine National
Institute of Health, The Use of Barbed Sutures in Obstetrics and
Gynecology, v.3(3); Summer 2010.
Dr. R.K. Mishra, Barbed Suture in Laparoscopic Surgery, Feb. 9,
2016.
Angiotech Puerto Rico, Inc., Quill™ Knotless Tissue-Closure Device
Product Catalog, 2007-2013.
Angiotech Pharmaceuticals, Inc. Quill™ SRS Product Catalog,
2009.
Covidien, V-Loc™ Wound Closure Devices Product Overview,
2011.
Covidien, V-Loc™ Wound Closure Device (the secure advantage),
2013.
DePuy Mitek, a Johnson & Johnson Company, MicroFix Absorb-
able QuickAnchor® Plus, Massachusetts, 2005.

* cited by examiner

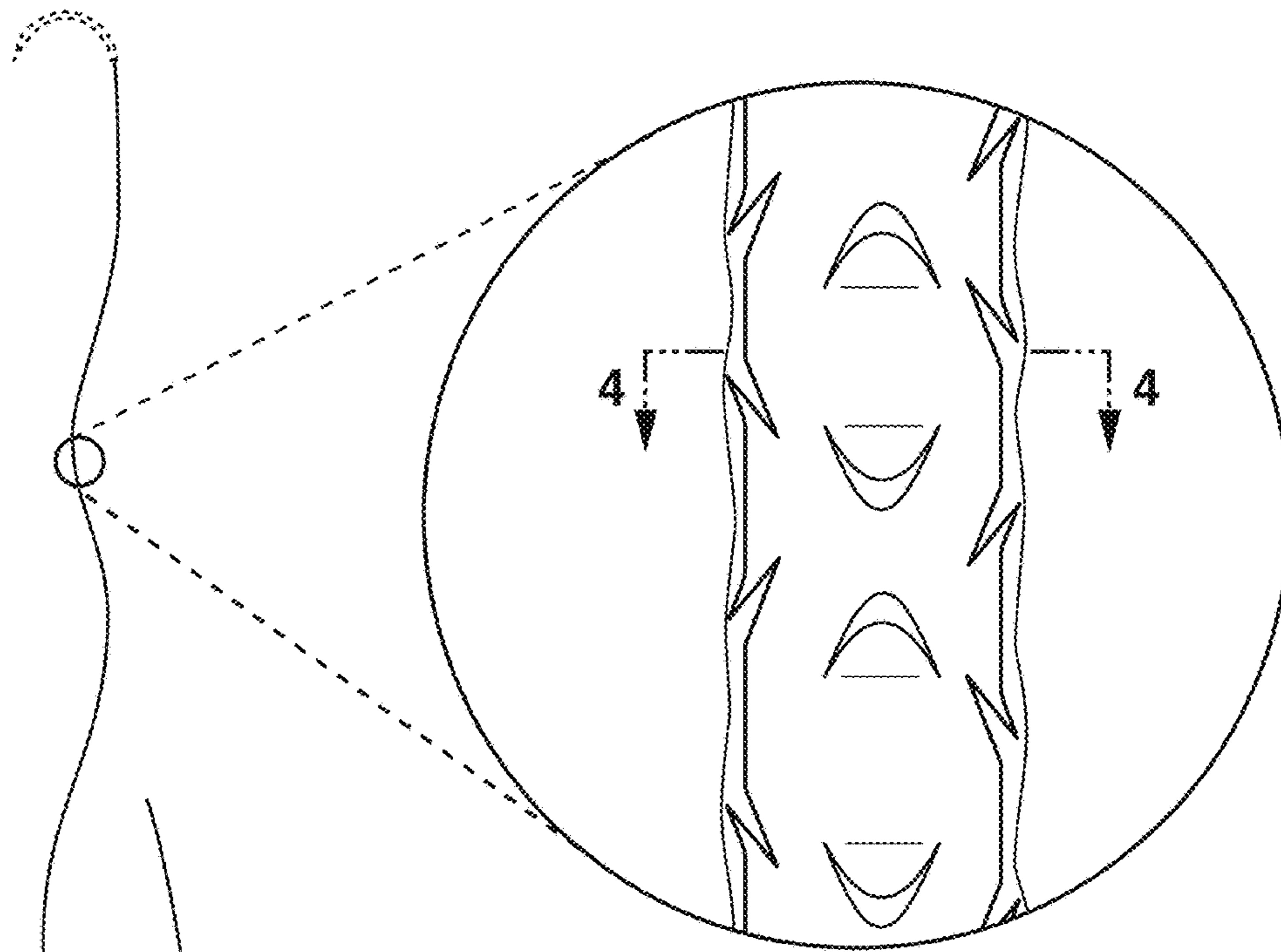

FIG. 2

FIG. 1



FIG. 3

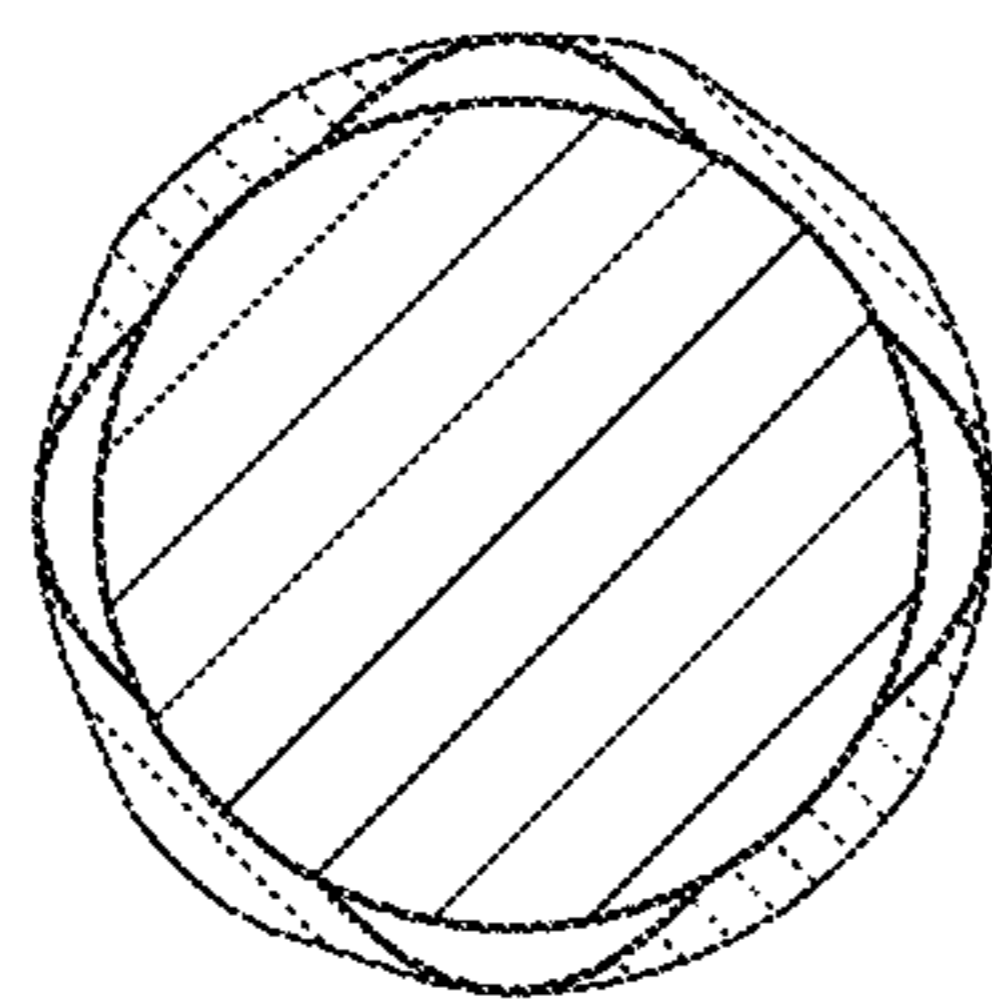

FIG. 4

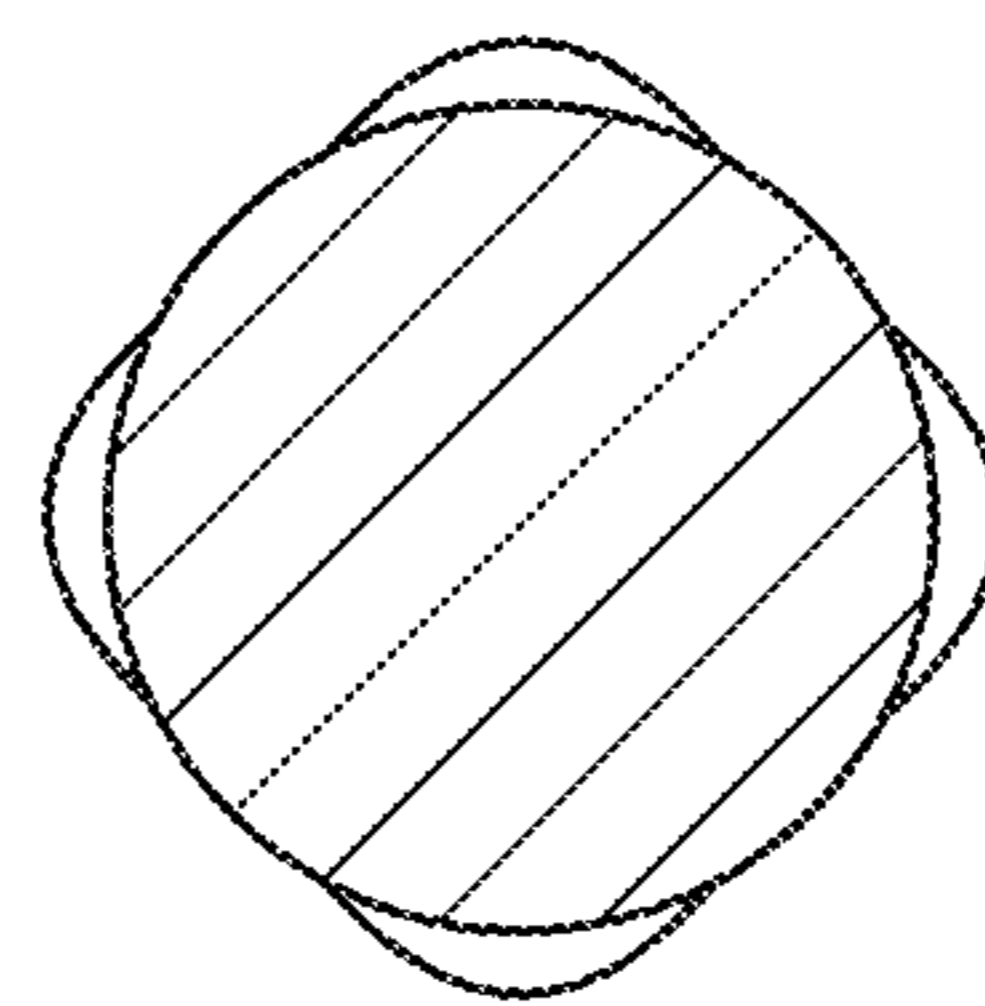

FIG. 5