



US00D870077S

(12) **United States Design Patent**  
**Kobayashi**

(10) **Patent No.:** **US D870,077 S**

(45) **Date of Patent:** **\*\* Dec. 17, 2019**

(54) **ELECTRONIC MUSICAL INSTRUMENT**

(71) Applicant: **Pioneer DJ CORPORATION**,  
Yokohama-shi, Kanagawa (JP)

(72) Inventor: **Jinta Kobayashi**, Tokyo (JP)

(73) Assignee: **Pioneer DJ CORPORATION**,  
Yokoahama-shi, Kanagawa (JP)

(\*\*) Term: **15 Years**

(21) Appl. No.: **29/624,750**

(22) Filed: **Nov. 3, 2017**

(30) **Foreign Application Priority Data**

Jun. 15, 2017 (JP) ..... 2017-012845

(51) **LOC (12) Cl.** ..... **14-01**

(52) **U.S. Cl.**  
USPC ..... **D14/217**

(58) **Field of Classification Search**  
USPC ..... D17/1-7, 9, 24, 99; D14/175, 188,  
D14/196-198, 217, 257, 258, 167-169,  
D14/162, 199, 203, 218, 356, 399-401,  
D14/412-416, 432, 434; D13/163, 162,  
D13/164, 174

CPC . G10F 1/02; G10H 1/02; G10H 1/045; G10H  
5/00; G10H 5/06; G10H 5/007; G10H  
5/02; G10H 5/04; G10H 1/0091; G10H  
1/04

See application file for complete search history.

(56) **References Cited**

**U.S. PATENT DOCUMENTS**

D259,722 S \* 6/1981 Fuller ..... D14/197  
D312,625 S \* 12/1990 Wetzel ..... D14/399  
D317,918 S \* 7/1991 Ito ..... D14/217  
D330,889 S \* 11/1992 Ishida ..... D14/399  
D429,233 S \* 8/2000 Komiyama ..... D14/167

D505,667 S \* 5/2005 Okada ..... D14/168  
D555,640 S \* 11/2007 Amiya ..... D14/217  
D578,514 S \* 10/2008 Mazur ..... D14/168  
D584,282 S \* 1/2009 Ishizaki ..... D14/188  
D605,604 S \* 12/2009 El-Kiss ..... D13/163  
D641,733 S \* 7/2011 Jenkins ..... D14/217  
D678,250 S \* 3/2013 O'Donnell ..... D14/217  
D687,019 S \* 7/2013 O'Donnell ..... D14/217  
D715,265 S \* 10/2014 Kuramoto ..... D14/217

(Continued)

**OTHER PUBLICATIONS**

Youtube, Namm 2015 Samson Conspiracy Midi Controller First  
Look AudioSavings.com, posted Jan. 25, 2015, [online], [site vis-  
ited Oct. 23, 2018]. Available from Internet, <URL: https://www.  
youtube.com/watch?v=eLeNLJakxUI> (Year: 2015).\*

(Continued)

*Primary Examiner* — Sheryl Lane

*Assistant Examiner* — Samantha N Wood

(74) *Attorney, Agent, or Firm* — Drinker Biddle & Reath  
LLP

(57) **CLAIM**

I claim the ornamental design for an electronic musical  
instrument, as shown and described.

**DESCRIPTION**

FIG. 1 is an upper-right-front perspective view showing the  
design.

FIG. 2 is a front view thereof.

FIG. 3 is a rear view thereof.

FIG. 4 is a left-side view thereof.

FIG. 5 is a right-side view thereof.

FIG. 6 is a top view thereof; and,

FIG. 7 is a bottom view thereof.

The broken lines are included for the purpose of illustrating  
the environmental structure and form no part of the claimed  
design.

**1 Claim, 7 Drawing Sheets**

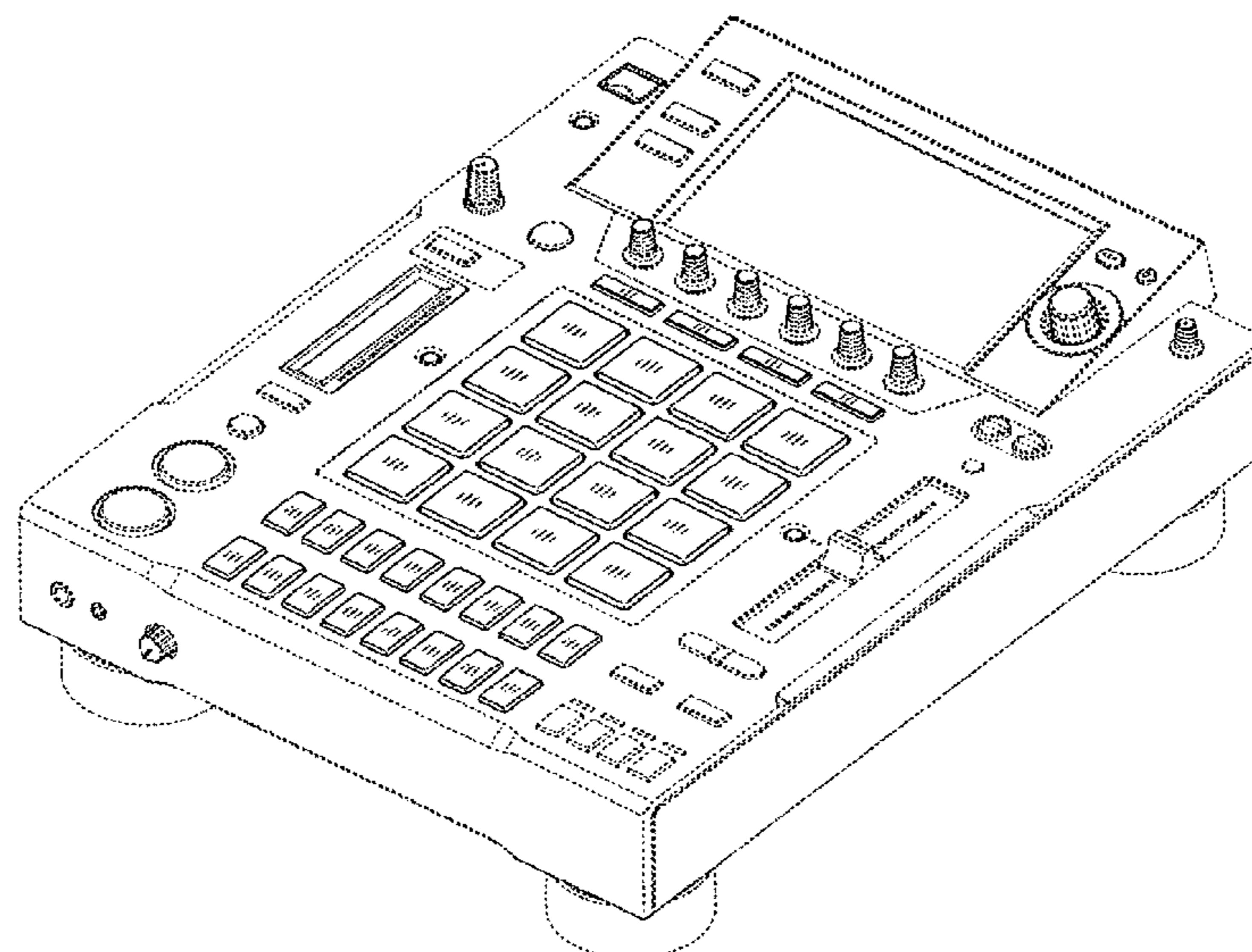

(56)

**References Cited**

U.S. PATENT DOCUMENTS

D717,278 S \* 11/2014 Amiya ..... D14/217  
D771,595 S \* 11/2016 Medas ..... D14/217

OTHER PUBLICATIONS

Amazon, Native Instruments Maschine Mikro MK2 Groove Production Studio, posted Mar. 9, 2013, [online], [site visited Oct. 23, 2018]. Available from Internet, <URL: <https://www.amazon.co.uk/Native-Instruments-Maschine-Groove-Production/dp/B00940TI0K>> (Year: 2013).\*

Amazon, Novation Launch Control XL Ableton Live Controller, posted Jul. 17, 2014, [online], [site visited Oct. 23, 2018]. Available from Internet, <URL: <https://www.amazon.com/Novation-Launch-Control-XL-Controller/dp/B00LXBC92M>> (Year: 2014).\*

Amazon, Ammoon Ancien Monde Panda Mini Portable Midi Controller, posted Mar. 17, 2016, [online], [site visited Oct. 24, 2018]. Available from Internet, <URL: <https://www.amazon.fr/ammoon-Portable-25-Touches-Clavier-Contr%C3%B4leur/dp/B01DGACVKM>> (Year: 2016).\*

\* cited by examiner

FIG. 1

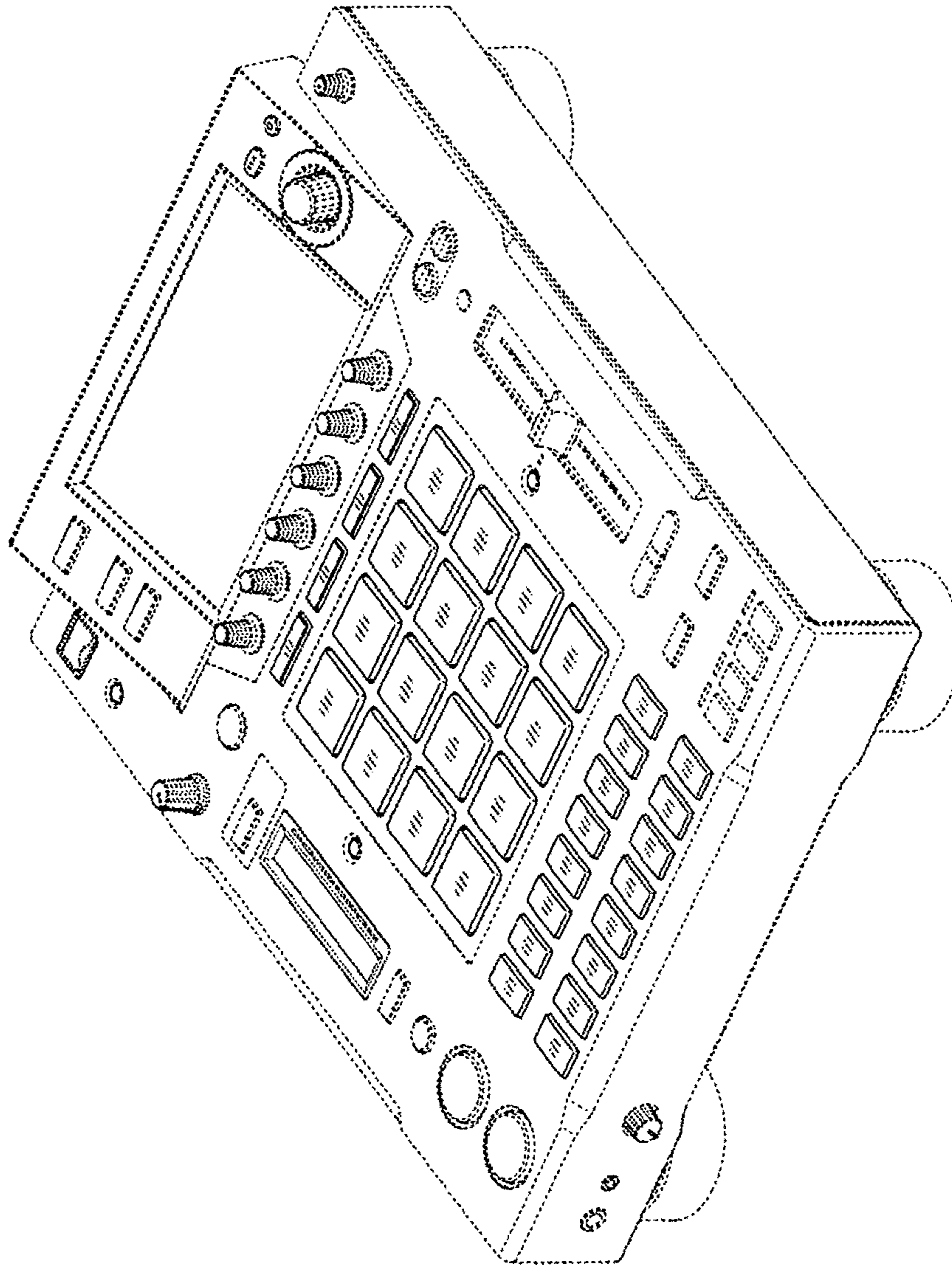

FIG. 2

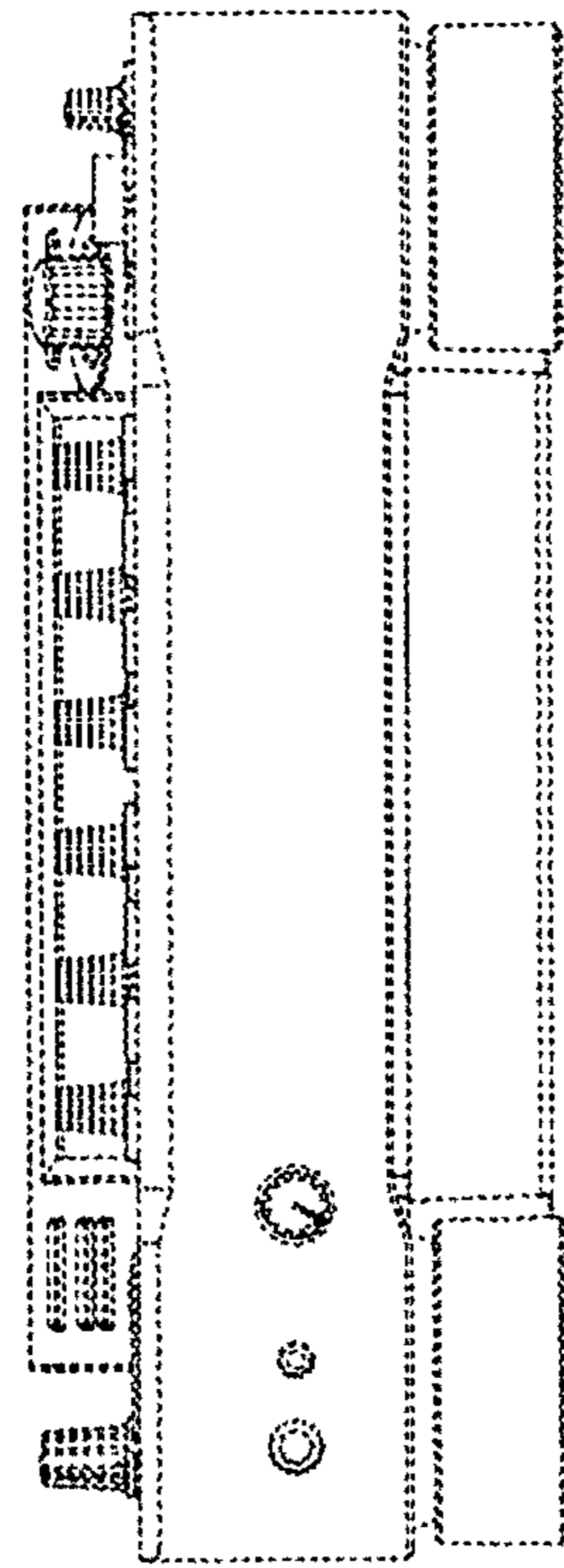



FIG. 3

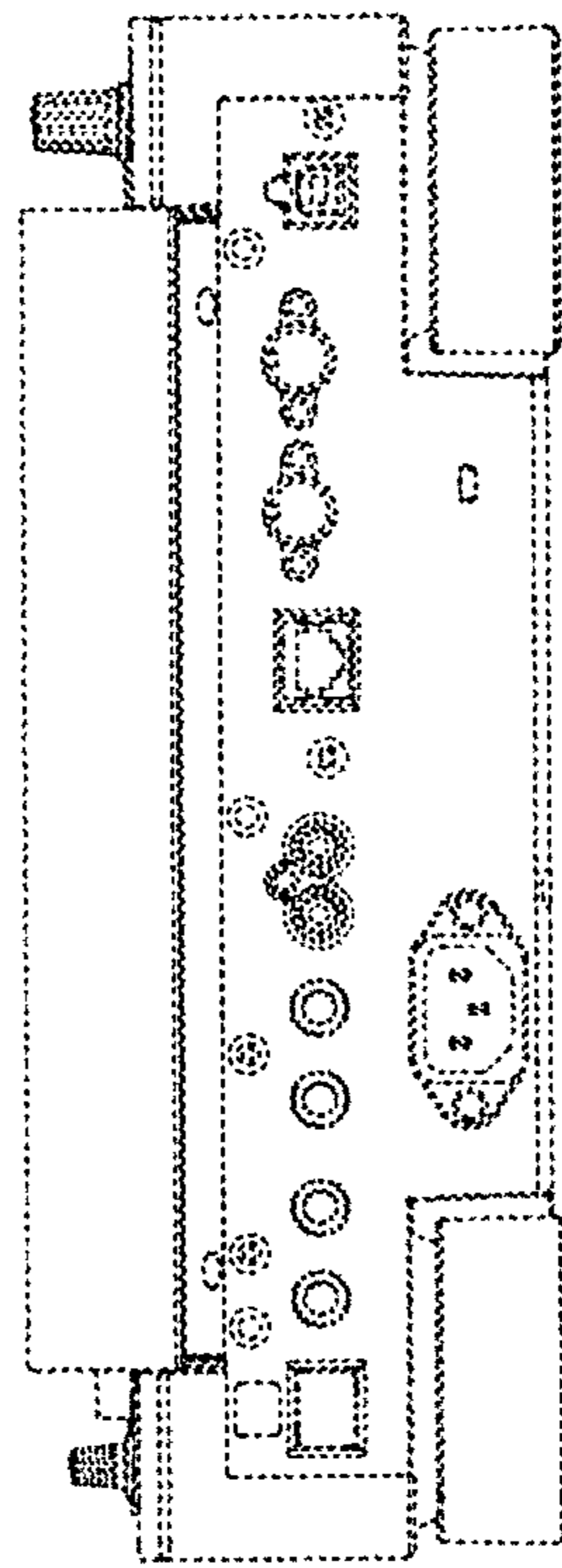

FIG. 4

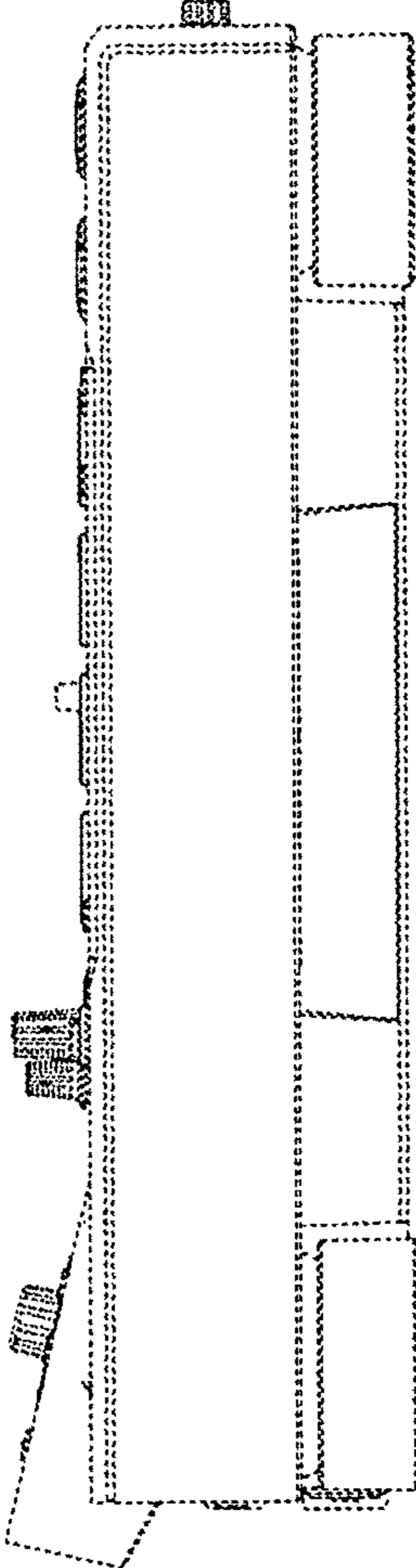

FIG. 5

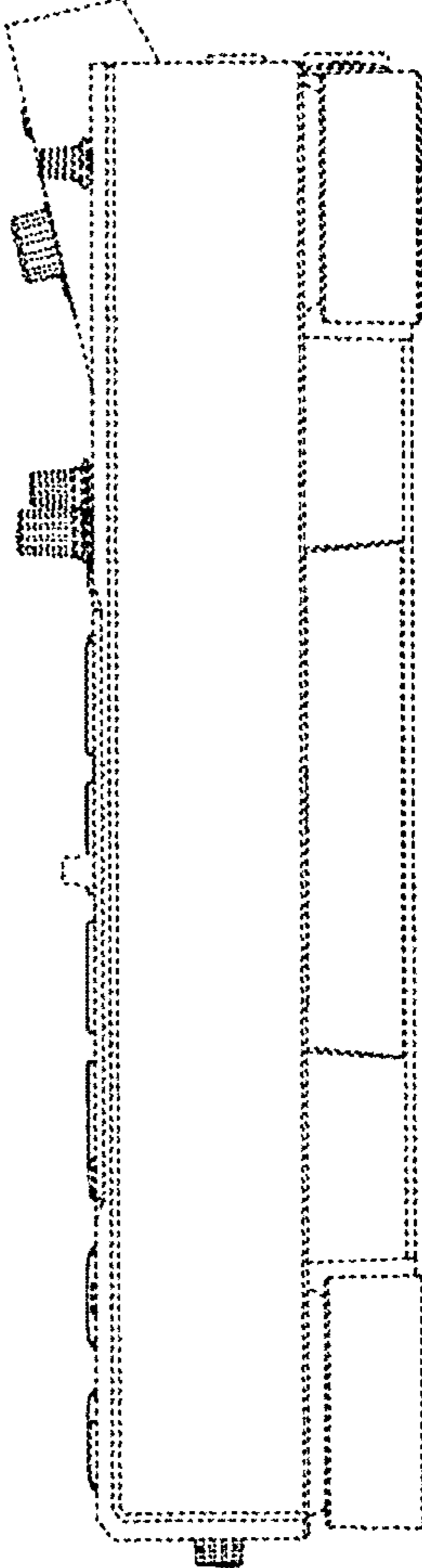

FIG. 6

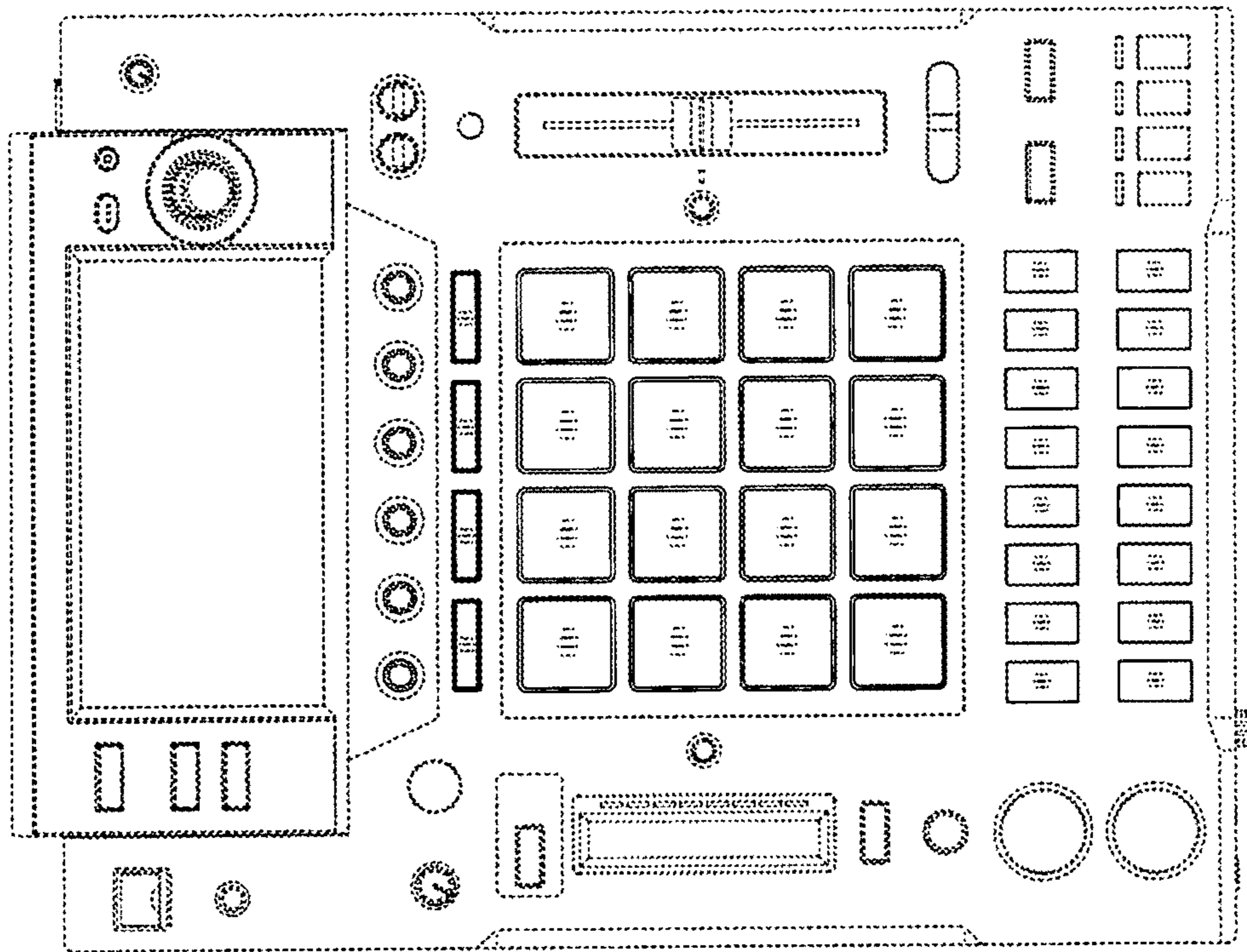



FIG. 7

