



US00D870038S

(12) **United States Design Patent**
Zeng

(10) **Patent No.:** **US D870,038 S**

(45) **Date of Patent:** **** Dec. 17, 2019**

(54) **CHARGING STATION**

(71) Applicant: **GN AUDIO A/S**, Ballerup (DK)

(72) Inventor: **Bill Zeng**, Xiamen (CN)

(73) Assignee: **GN AUDIO A/S** (DK)

(**) Term: **15 Years**

(21) Appl. No.: **29/598,884**

(22) Filed: **Mar. 29, 2017**

(51) **LOC (12) Cl.** **13-02**

(52) **U.S. Cl.**
USPC **D13/108**

(58) **Field of Classification Search**
USPC D13/109–110, 118–119, 184, 199,
D13/107–108; D14/251, 253, 432, 434
CPC Y02E 60/12; Y02T 90/14; Y02T 90/122;
Y02T 90/128; Y02T 90/163; Y02T
10/7005; Y02T 10/7088; H02J 7/025;
H02J 7/0042; H02J 7/0044; H02J 7/0045;
H02J 7/0003; H01F 38/14; H01R
13/6675; H01M 2/1022; H01M 2/1055;
H01M 10/44; H01M 10/46; H01M
10/425; B60L 11/182
See application file for complete search history.

(56) **References Cited**

U.S. PATENT DOCUMENTS

| | | | | |
|--------------|---------|----------|-------|---------|
| D442,141 S * | 5/2001 | Ikenaga | | D13/107 |
| D489,325 S * | 5/2004 | Nakamura | | D13/110 |
| D507,526 S * | 7/2005 | Ohta | | D13/108 |
| D520,013 S * | 5/2006 | Yang | | D14/434 |
| D523,847 S * | 6/2006 | Naruki | | D13/108 |
| D606,545 S * | 12/2009 | Salmon | | D13/108 |

| | | | | |
|--------------|---------|--------|-------|---------|
| D607,817 S * | 1/2010 | Tan | | D13/108 |
| D642,519 S * | 8/2011 | Woo | | D13/108 |
| D674,336 S * | 1/2013 | Suzuka | | D13/108 |
| D675,155 S * | 1/2013 | Smith | | D13/108 |
| D684,145 S | 6/2013 | Rath | | |
| D772,216 S * | 11/2016 | Lau | | D13/108 |
| D772,812 S * | 11/2016 | Choe | | D13/108 |
| D806,024 S * | 12/2017 | Swen | | D13/108 |
| D812,564 S * | 3/2018 | Feng | | D13/108 |
| D815,594 S * | 4/2018 | Chen | | D13/108 |
| D845,896 S * | 4/2019 | Hu | | D13/108 |

* cited by examiner

Primary Examiner — Rosemary K Tarca

(74) *Attorney, Agent, or Firm* — Hamre, Schumann,
Mueller & Larson, P.C.

(57) **CLAIM**

The ornamental design for a charging station, as shown and described.

DESCRIPTION

FIG. 1 is a front perspective view of a charging station, showing our new design.

FIG. 2 is a back perspective view FIG. 1 thereof.

FIG. 3 is a front elevational view of FIG. 1 thereof.

FIG. 4 is a back elevational view of FIG. 1 thereof.

FIG. 5 is a right side elevational view of FIG. 1 thereof.

FIG. 6 is a left side elevational view of FIG. 1 thereof.

FIG. 7 is a top plan view of FIG. 1 thereof; and,

FIG. 8 is a bottom plan view of FIG. 1 thereof.

The evenly dashed broken lines in the drawings are for the purpose of illustrating portions of the charging station which form no part of the claimed design. The evenly dashed broken lines immediately adjacent to shaded areas represent the bounds of the claimed design and form no part thereof.

1 Claim, 8 Drawing Sheets

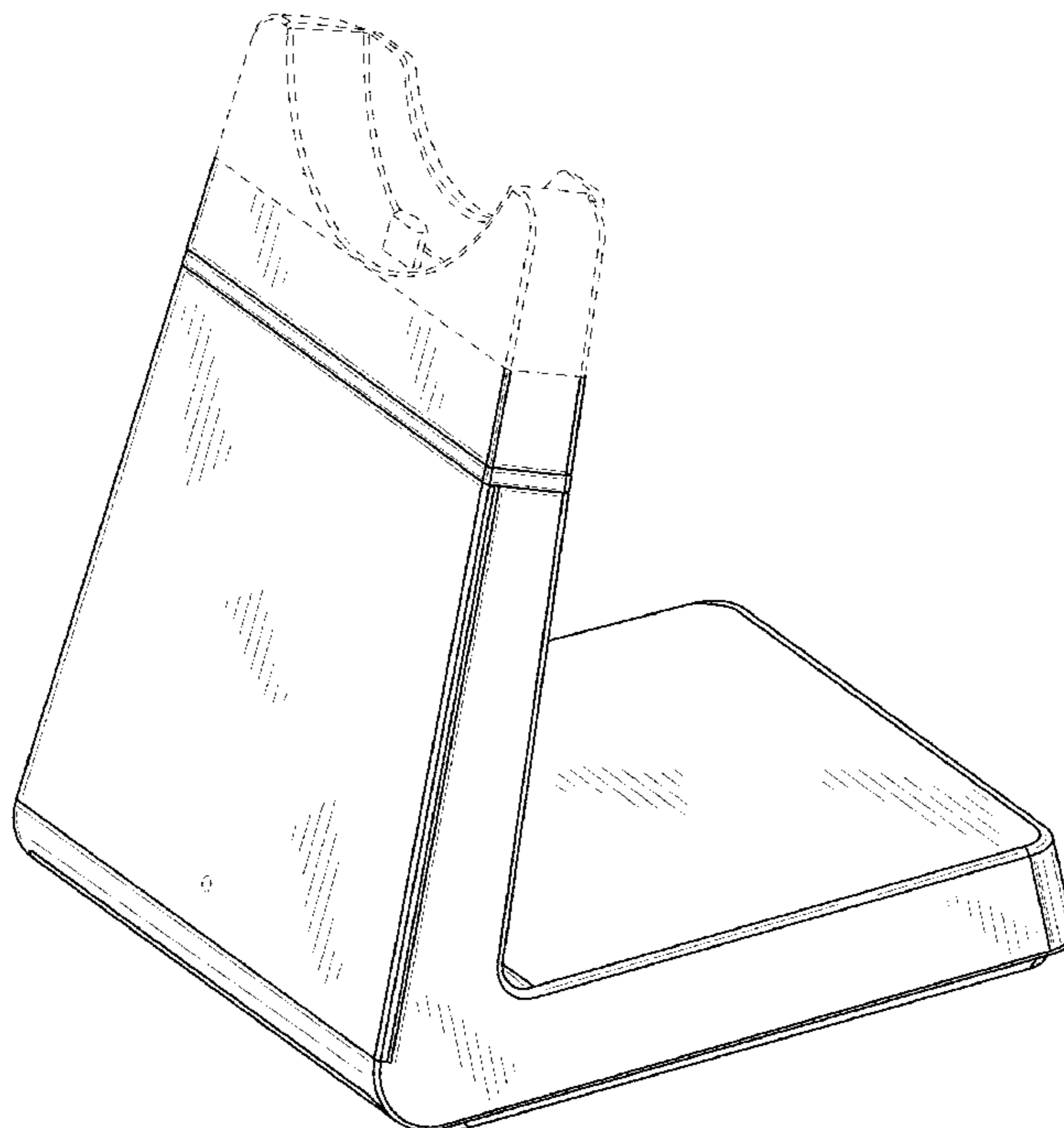

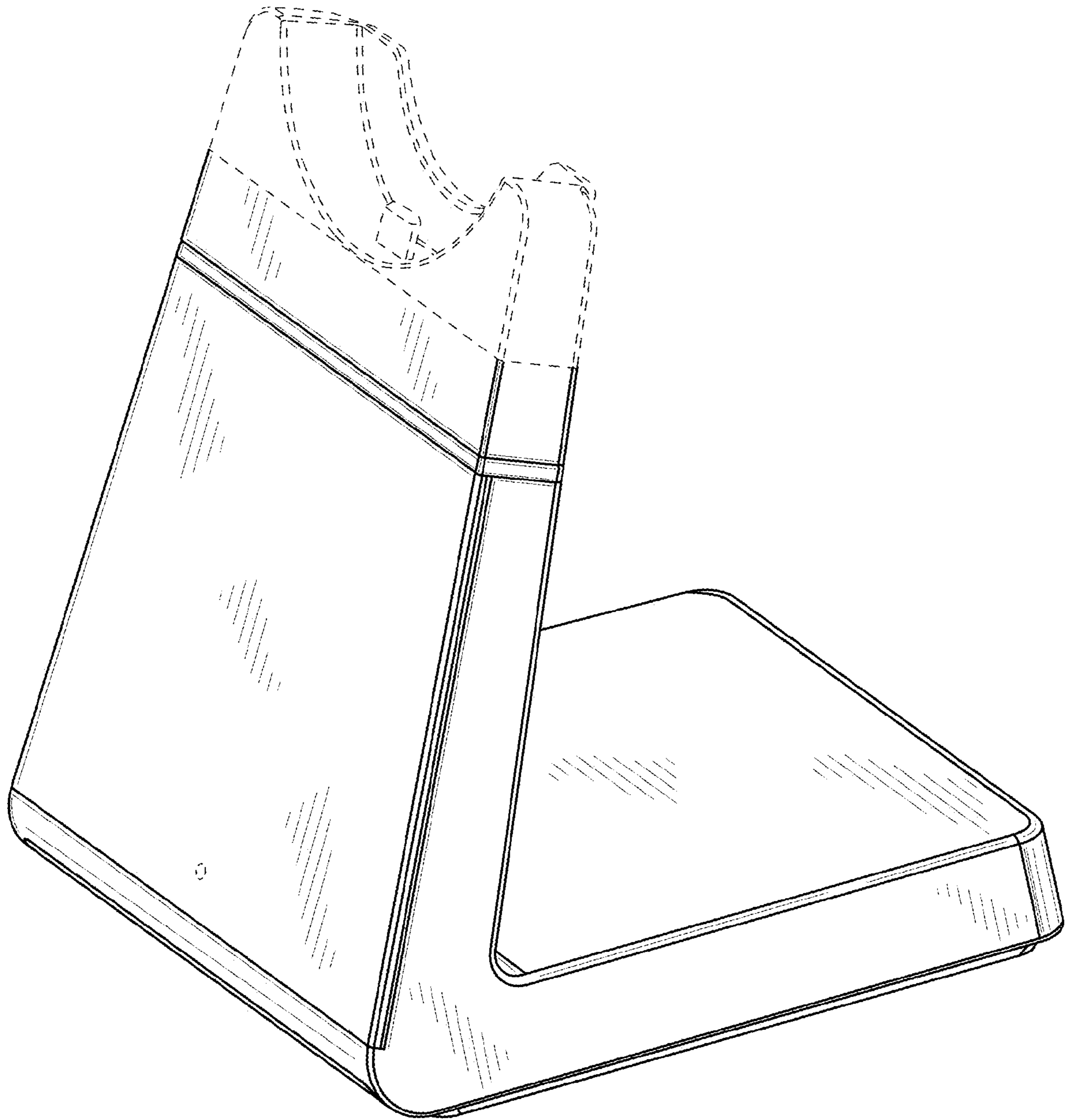

FIG. 1

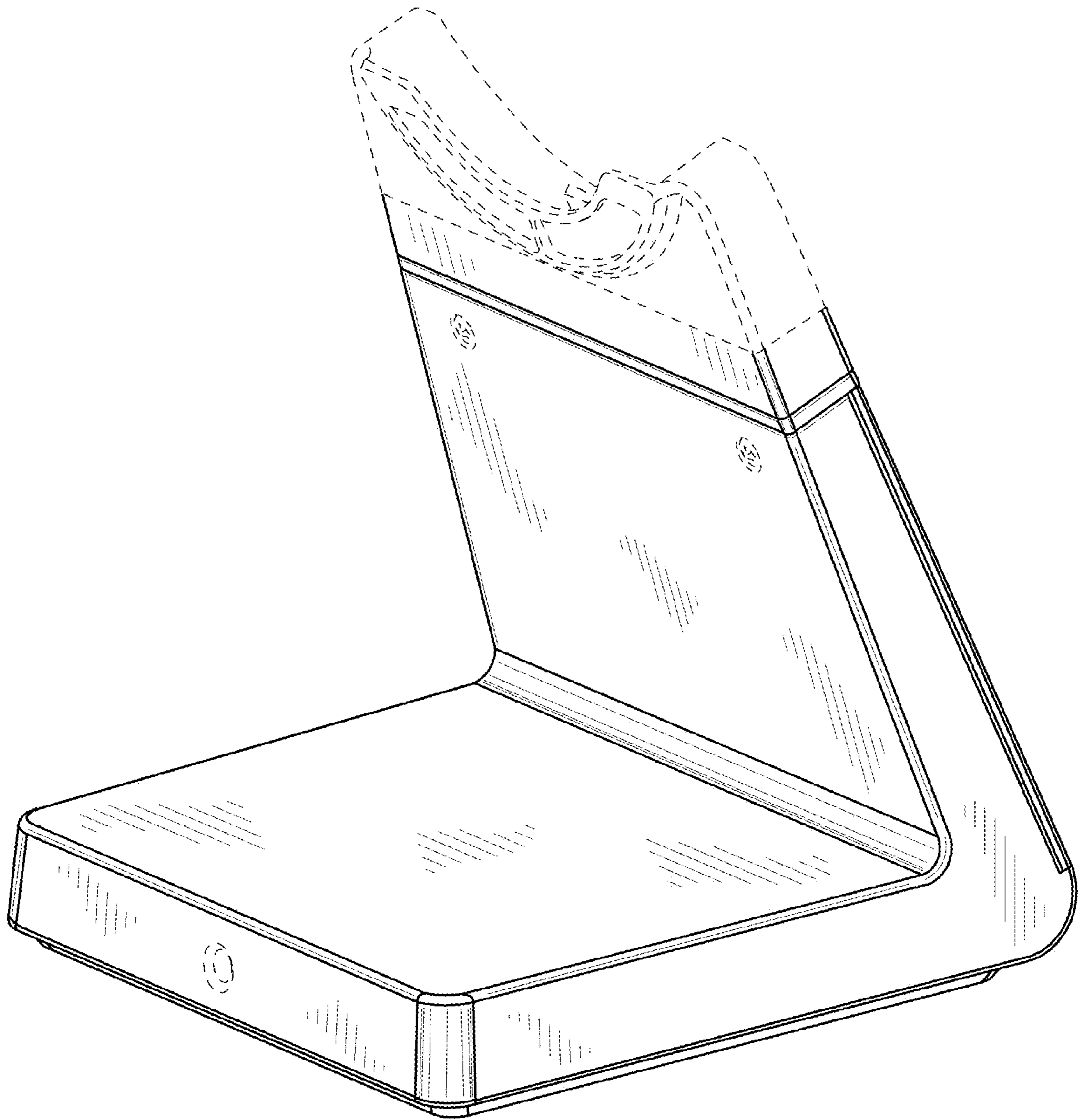

FIG. 2

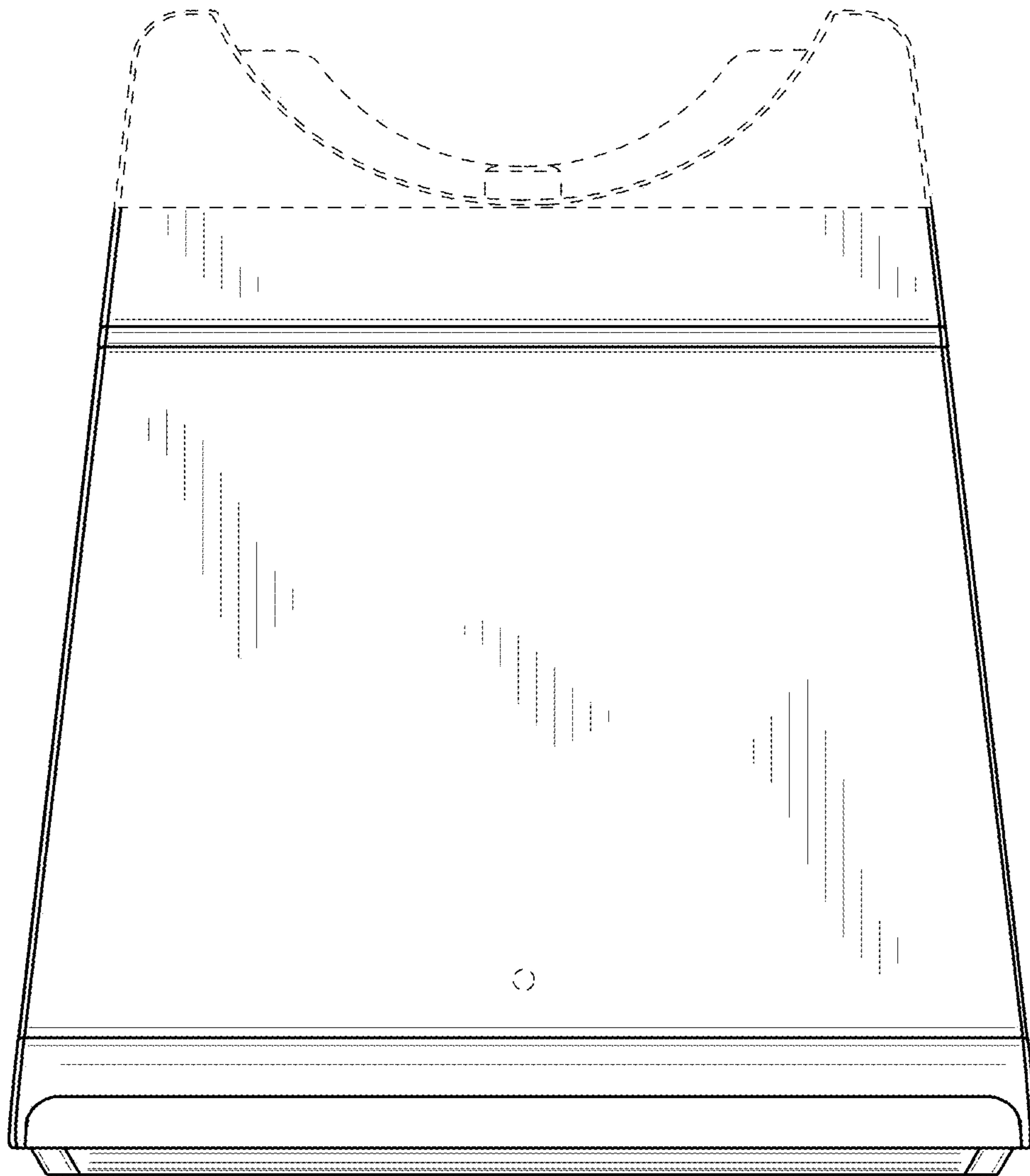

FIG. 3

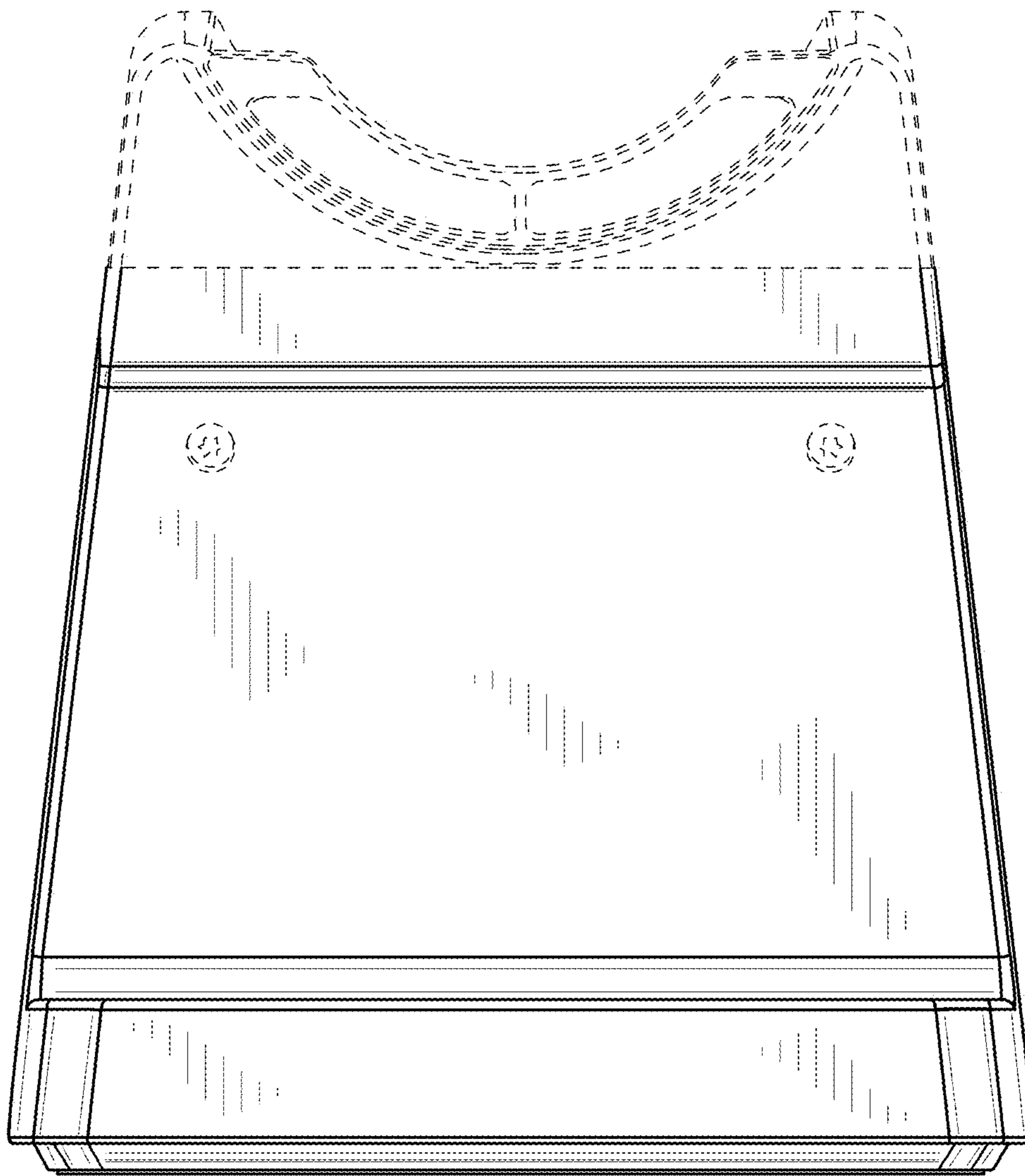

FIG. 4

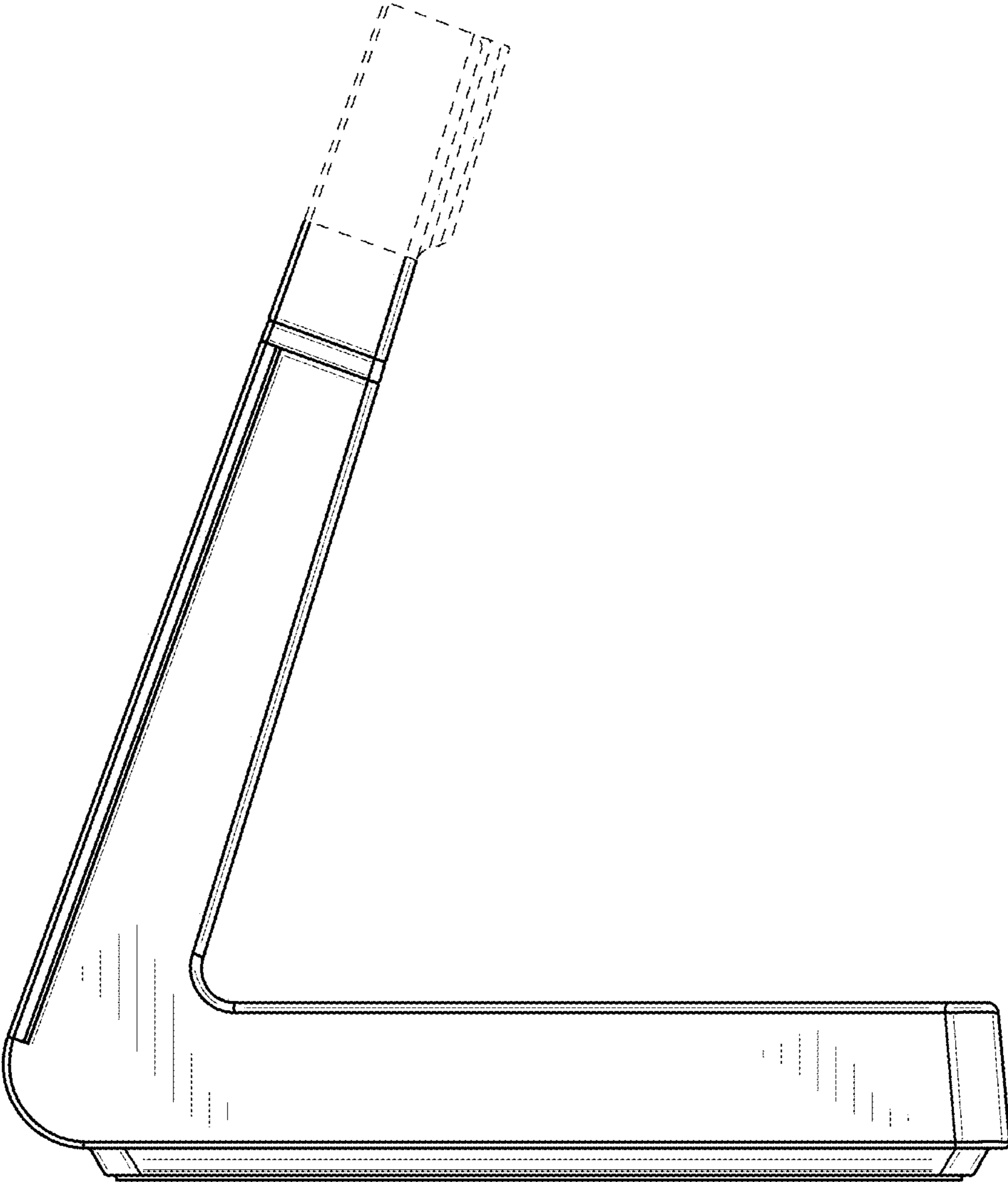

FIG. 5

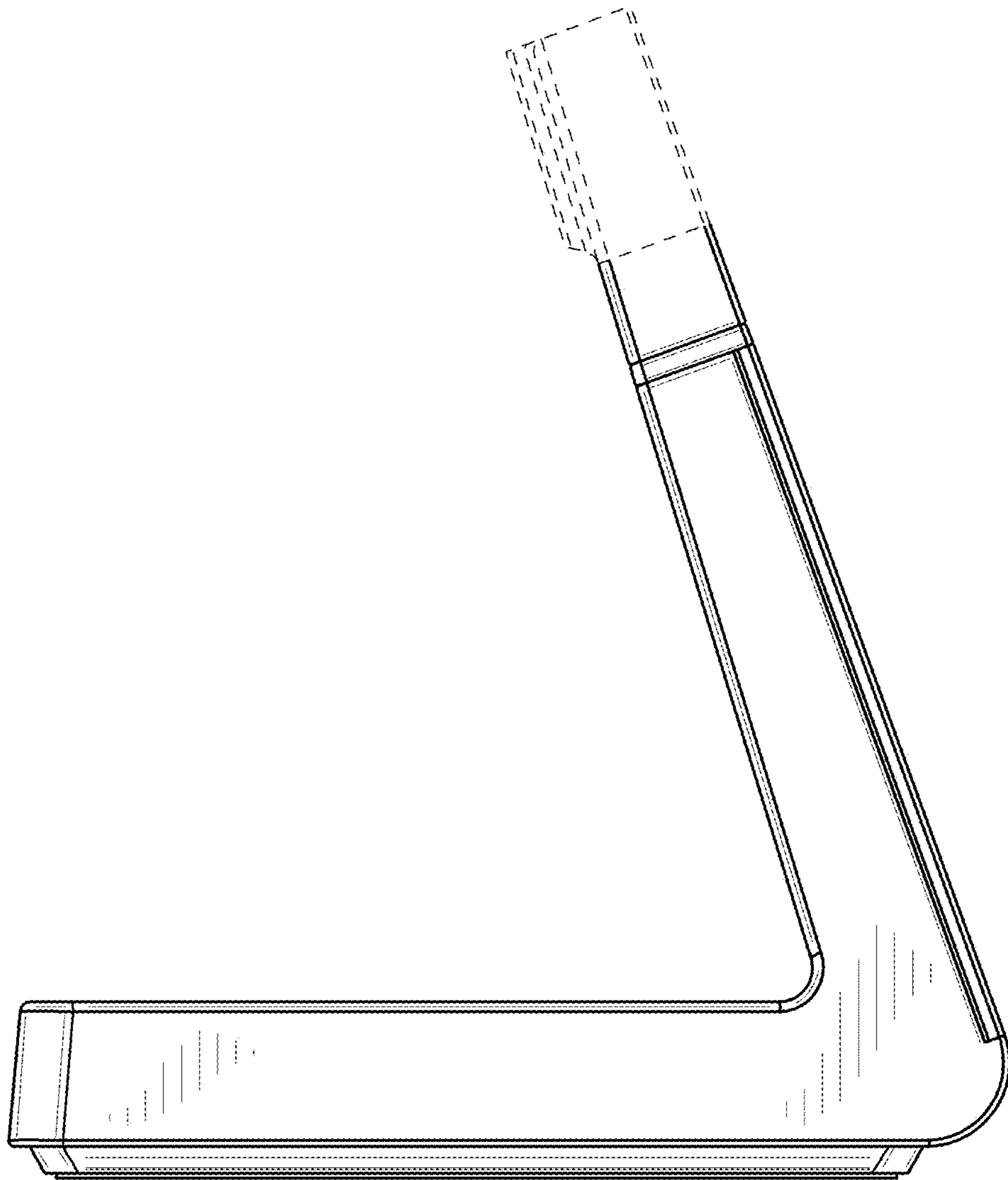

FIG. 6

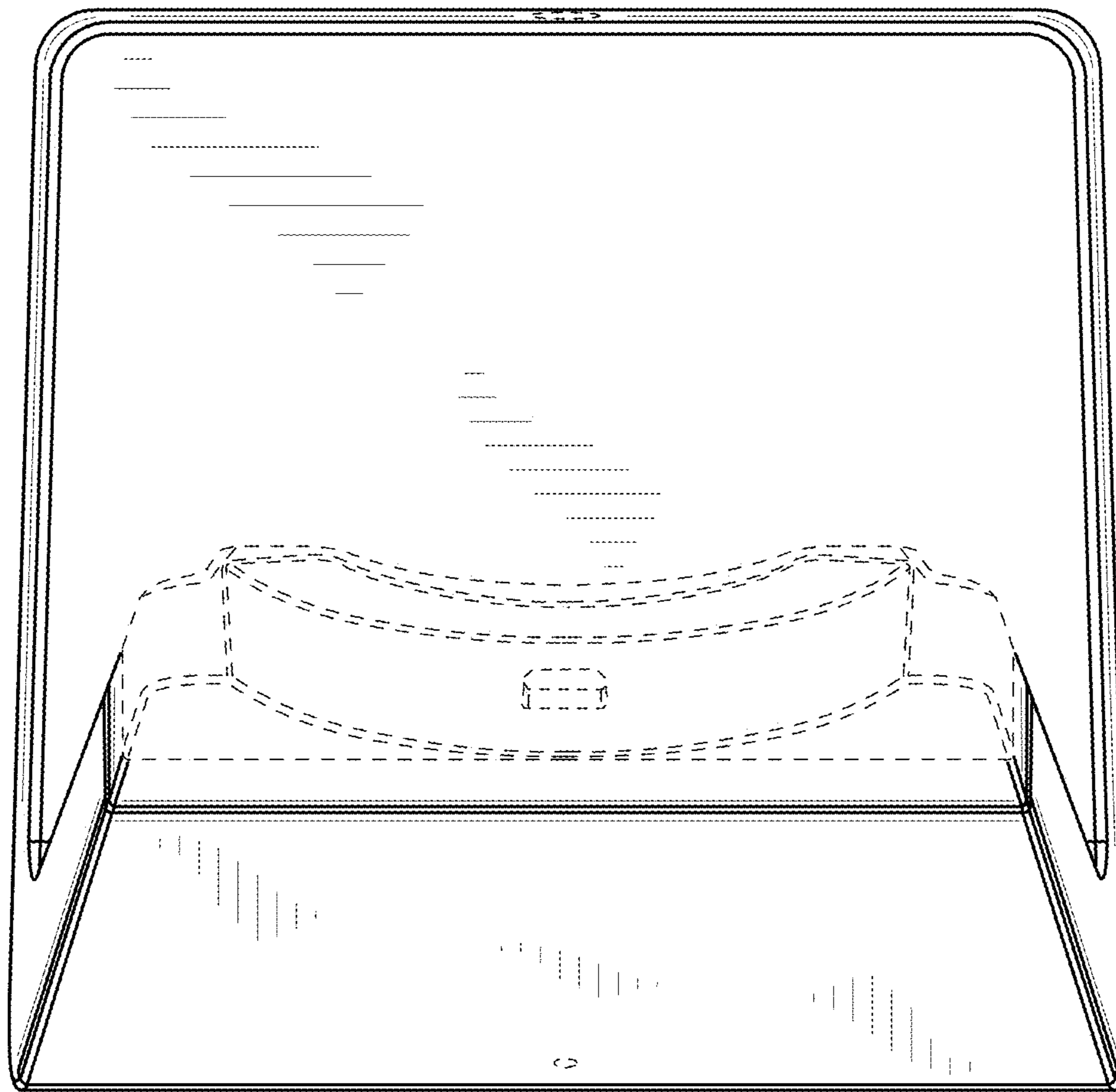

FIG. 7

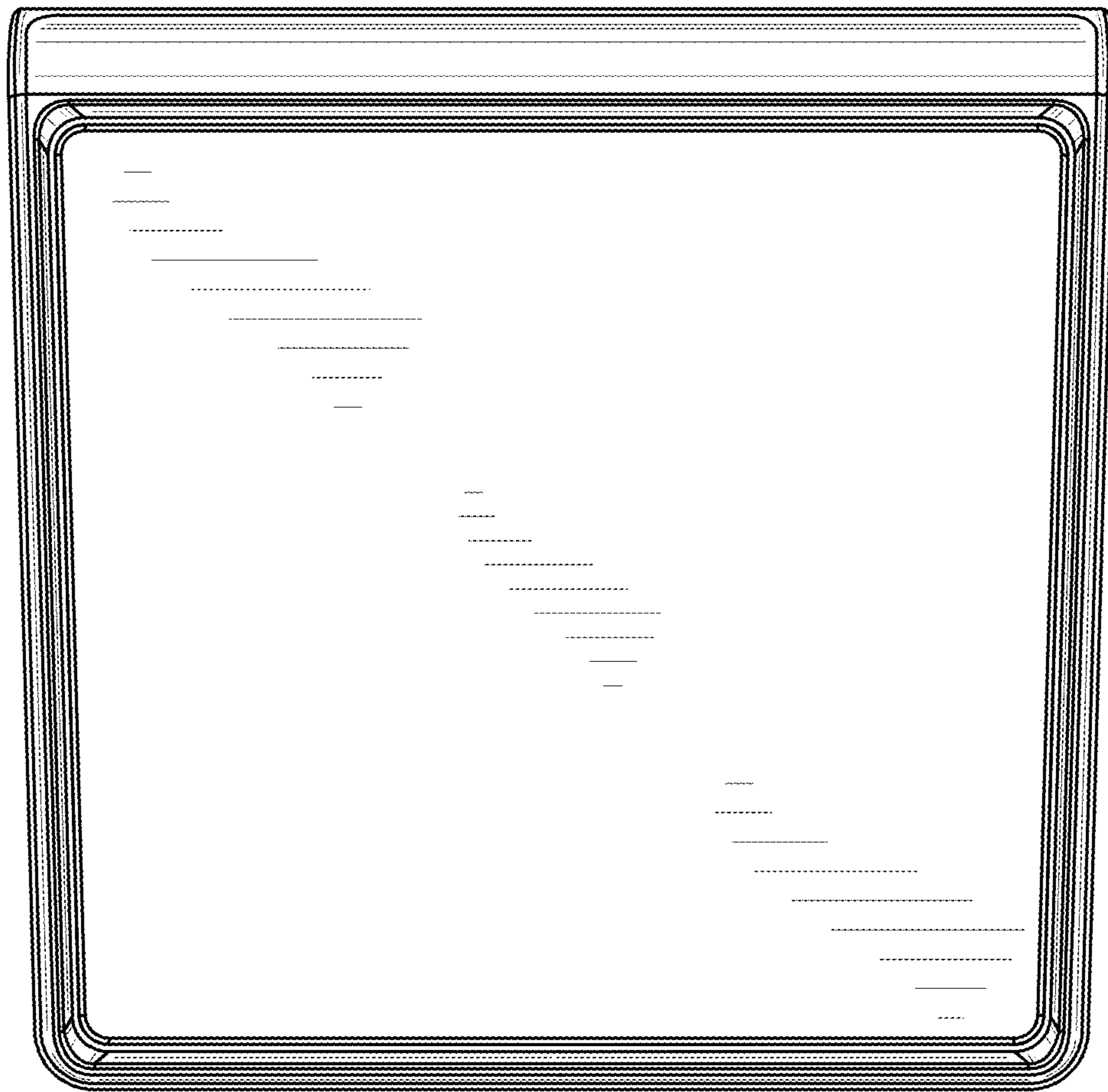

FIG. 8