



US00D870017S

(12) **United States Design Patent** (10) **Patent No.:** **US D870,017 S**
Meng (45) **Date of Patent:** **** Dec. 17, 2019**

(54) **AIRCRAFT**
(71) Applicant: **Xiao Meng**, Hong Kong (HK)
(72) Inventor: **Xiao Meng**, Hong Kong (HK)
(**) Term: **15 Years**
(21) Appl. No.: **29/689,926**
(22) Filed: **May 3, 2019**
(51) **LOC (12) Cl.** **12-07**
(52) **U.S. Cl.**
USPC **D12/328**
(58) **Field of Classification Search**
USPC D12/1-4, 16.1, 319-345; D21/436-454;
D30/160
CPC B64C 39/024; B64C 13/16; B64C 19/00;
B64C 2201/021; B64C 2201/141; B60H
1/3442
See application file for complete search history.

10,106,254 B2 * 10/2018 Vedamanikam B64C 29/0016
10,131,422 B2 * 11/2018 Matsumoto B64C 27/006
D834,996 S * 12/2018 Zheng D12/16.1
10,149,916 B2 * 12/2018 Taoka A61L 9/22
D847,017 S * 4/2019 Kim D12/16.1
D847,021 S * 4/2019 Kim D12/16.1
2005/0096800 A1 * 5/2005 Tanielian B64C 39/024
701/2
2015/0293227 A1 * 10/2015 Taoka G01N 15/06
356/338
2016/0200415 A1 * 7/2016 Cooper A63H 27/12
244/17.15
2017/0313441 A1 * 11/2017 Tsai B64C 39/024
2018/0111684 A1 * 4/2018 Namgoong B64C 39/024

* cited by examiner

Primary Examiner — Marissa J Cash
(74) *Attorney, Agent, or Firm* — W&K IP

(57) **CLAIM**

The ornamental design for a aircraft, as shown and described.

DESCRIPTION

FIG. 1 is a front side view of the aircraft in accordance with of the present invention;
FIG. 2 is a back side view of the aircraft depicted in FIG. 1;
FIG. 3 is a left side view of the aircraft depicted in FIG. 1;
FIG. 4 is a right side view of the aircraft depicted in FIG. 1;
FIG. 5 is a top view of the aircraft depicted in FIG. 1;
FIG. 6 is a bottom view of the aircraft depicted in FIG. 1;
FIG. 7 is a top perspective view of the aircraft depicted in FIG. 1; and,
FIG. 8 is bottom perspective view of the aircraft depicted in FIG. 1.

The broken lines shown in the drawings illustrate portions of the aircraft and form no part of the claimed design.

1 Claim, 6 Drawing Sheets

(56) **References Cited**

U.S. PATENT DOCUMENTS

D274,999 S 8/1984 Reeves
D292,194 S * 10/1987 Moller D12/325
D326,873 S * 6/1992 Chang D11/157
5,203,521 A * 4/1993 Day B64C 39/064
244/12.2
D430,530 S * 9/2000 Milde, Jr. D12/320
D665,332 S 8/2012 Vicente et al.
D669,836 S * 10/2012 Ordonez D12/213
D760,624 S * 7/2016 Balaesque D12/16.1
9,529,086 B2 * 12/2016 Taoka G01N 15/06
D780,665 S * 3/2017 Blincow D12/320
D817,252 S * 5/2018 Kim D12/325
10,053,217 B2 * 8/2018 Cho G08G 1/09
D830,228 S * 10/2018 Grassi D12/16.1
D830,897 S * 10/2018 Choi D12/16.1

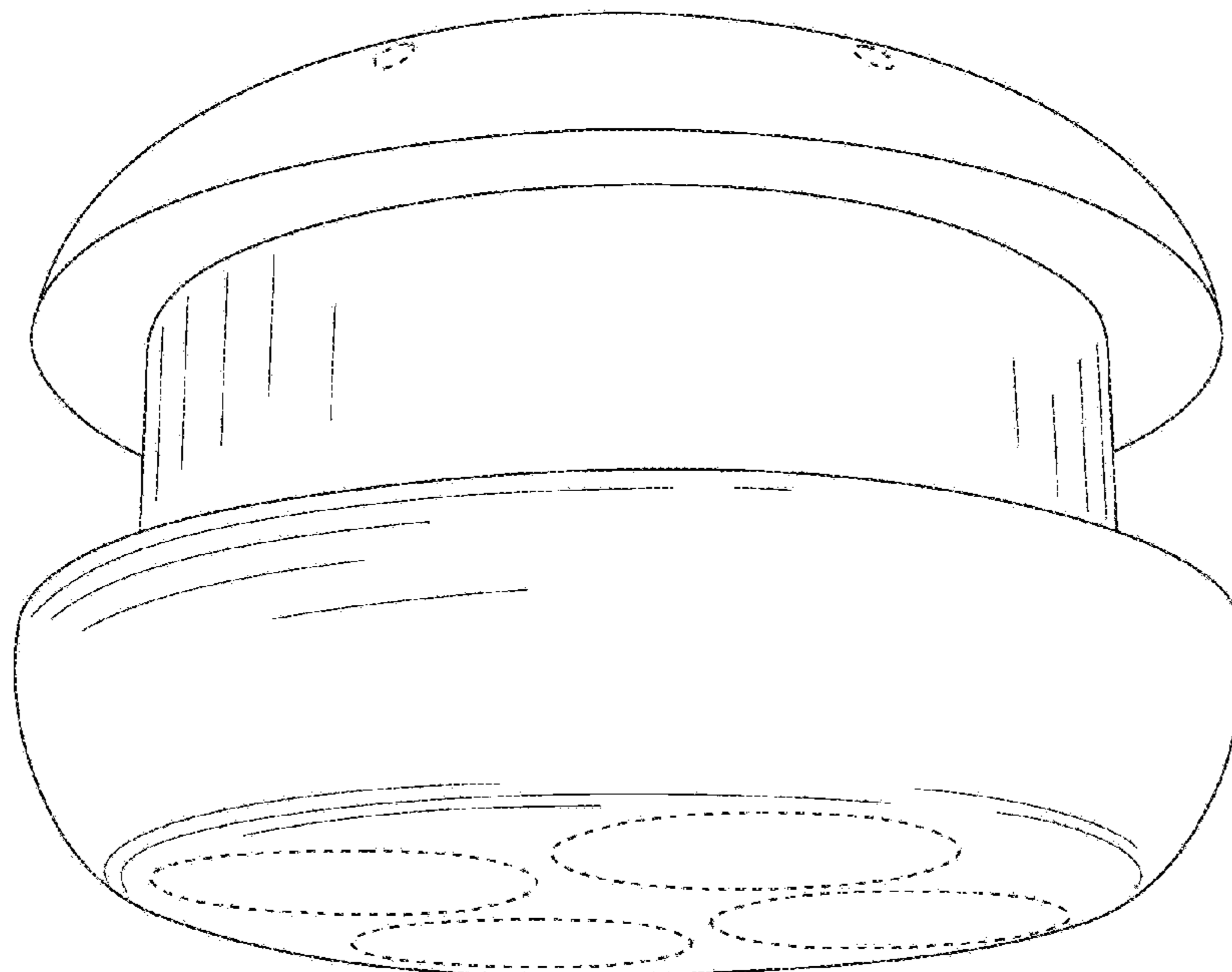

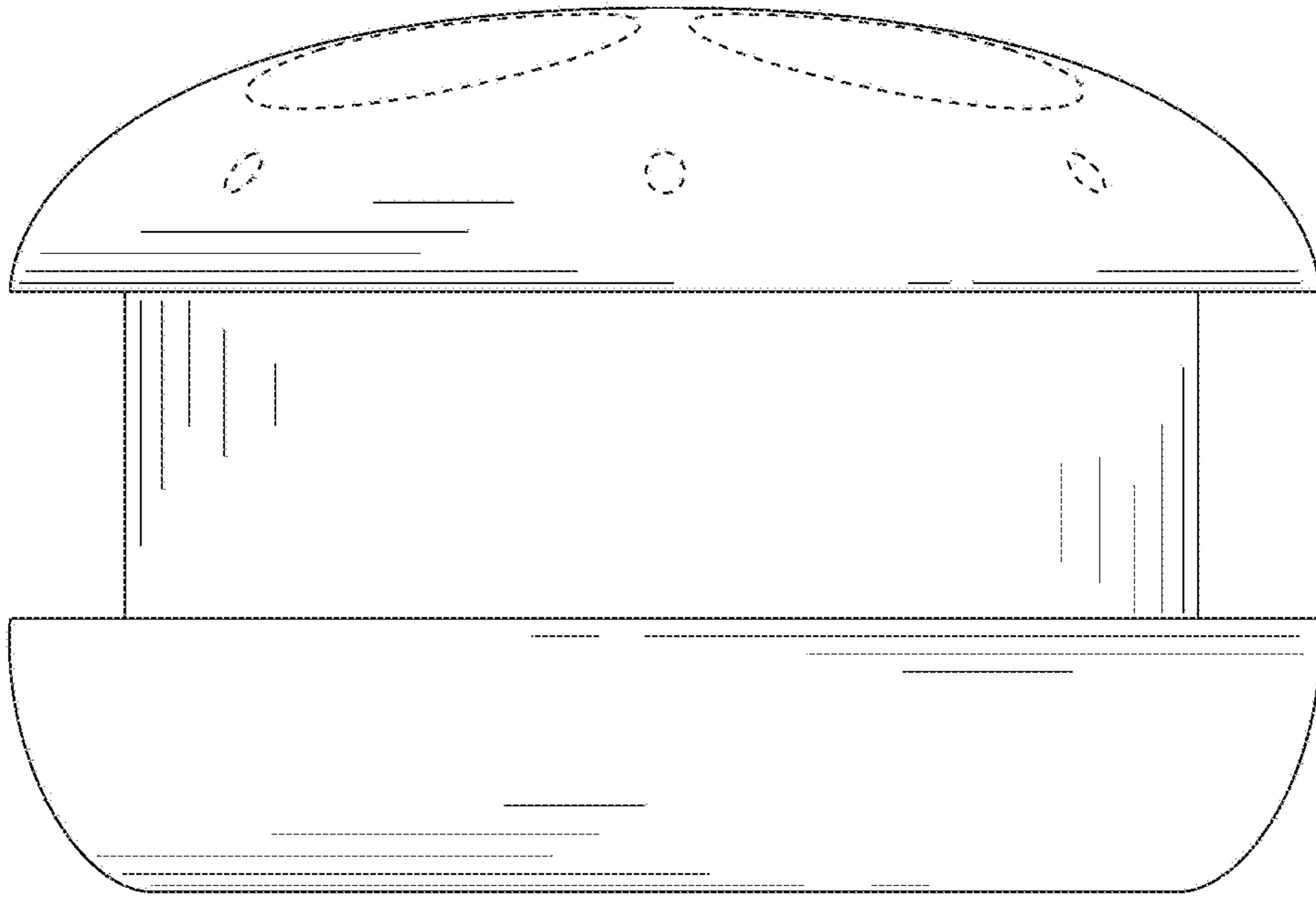

FIG. 1

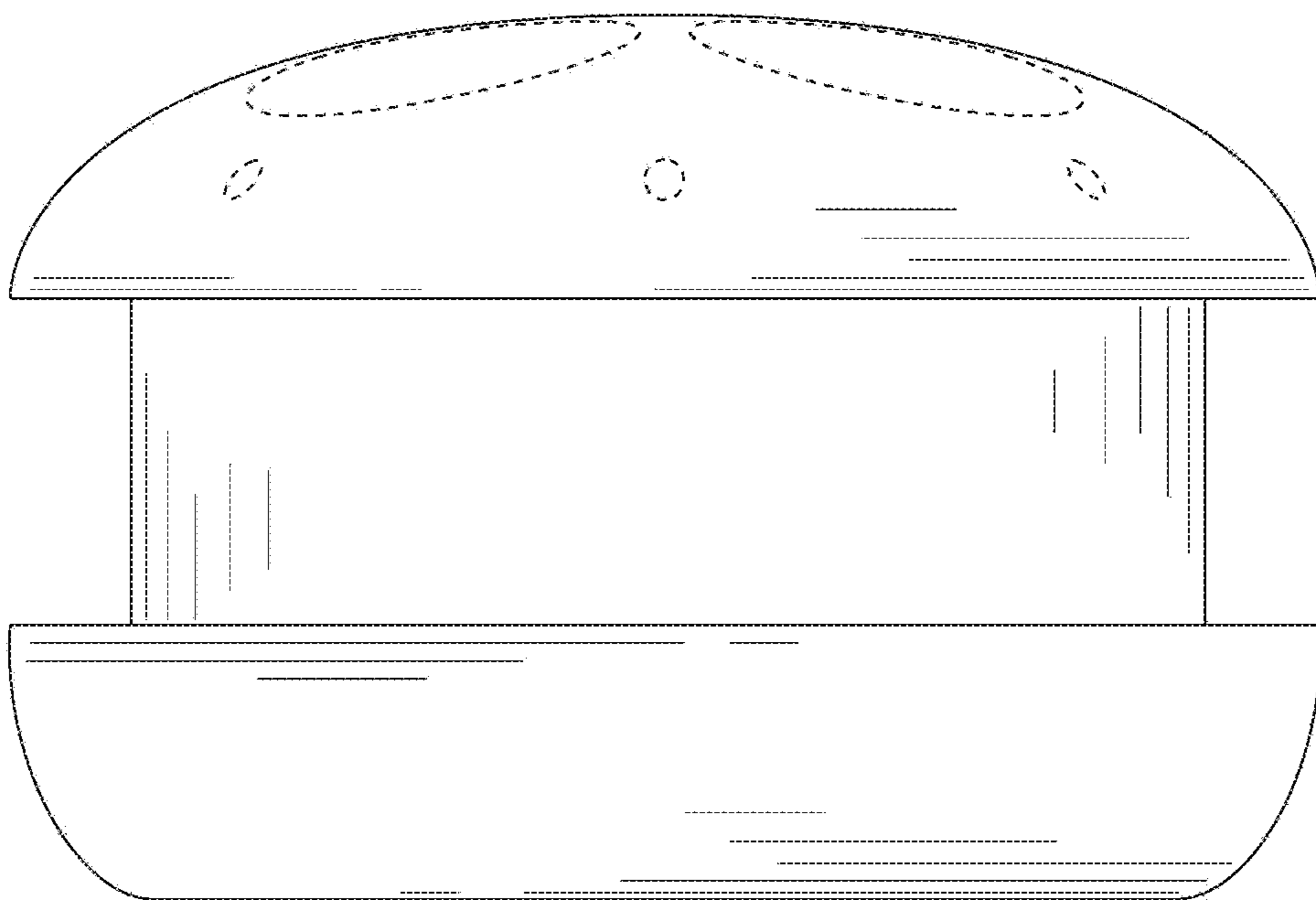

FIG. 2

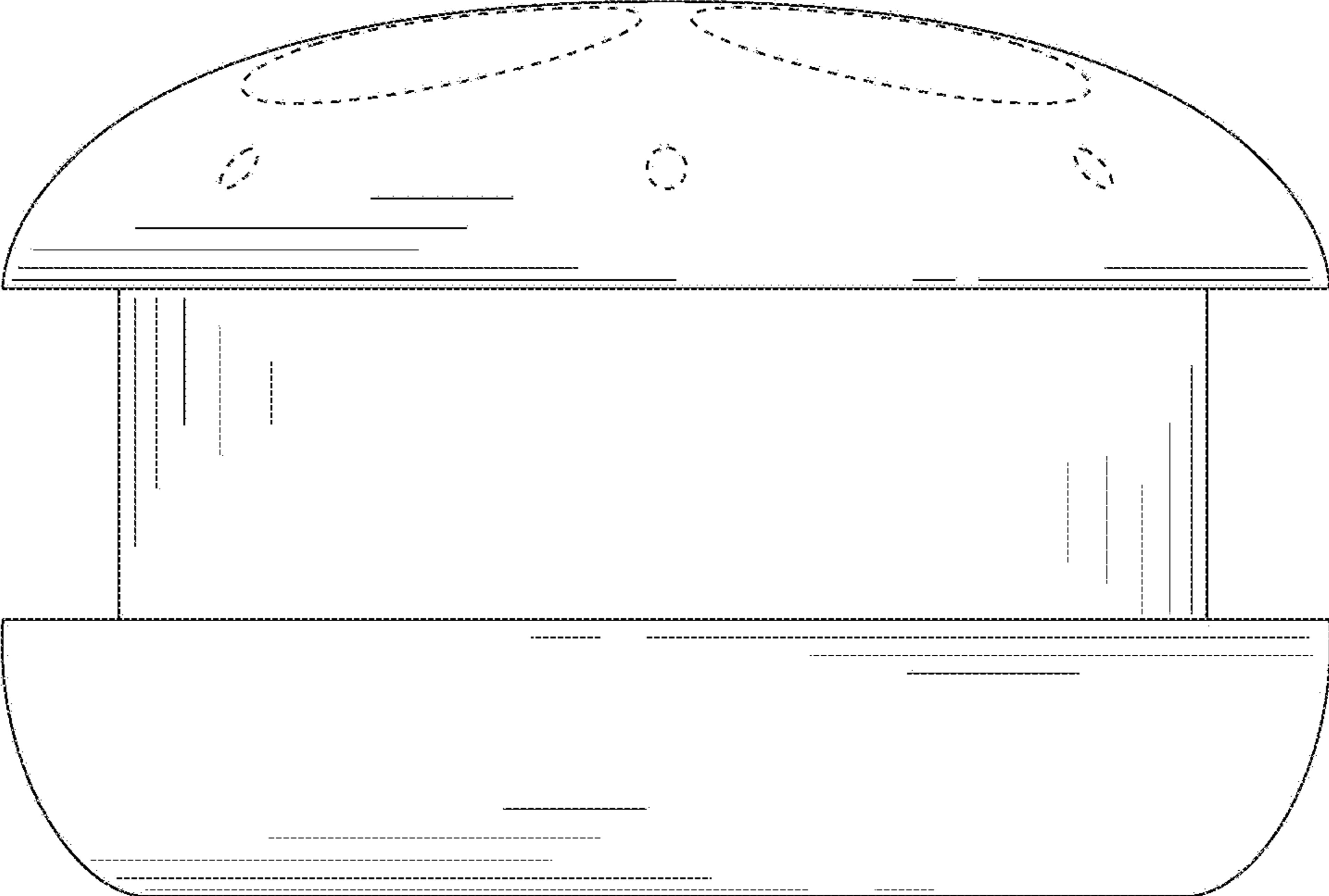

FIG. 3

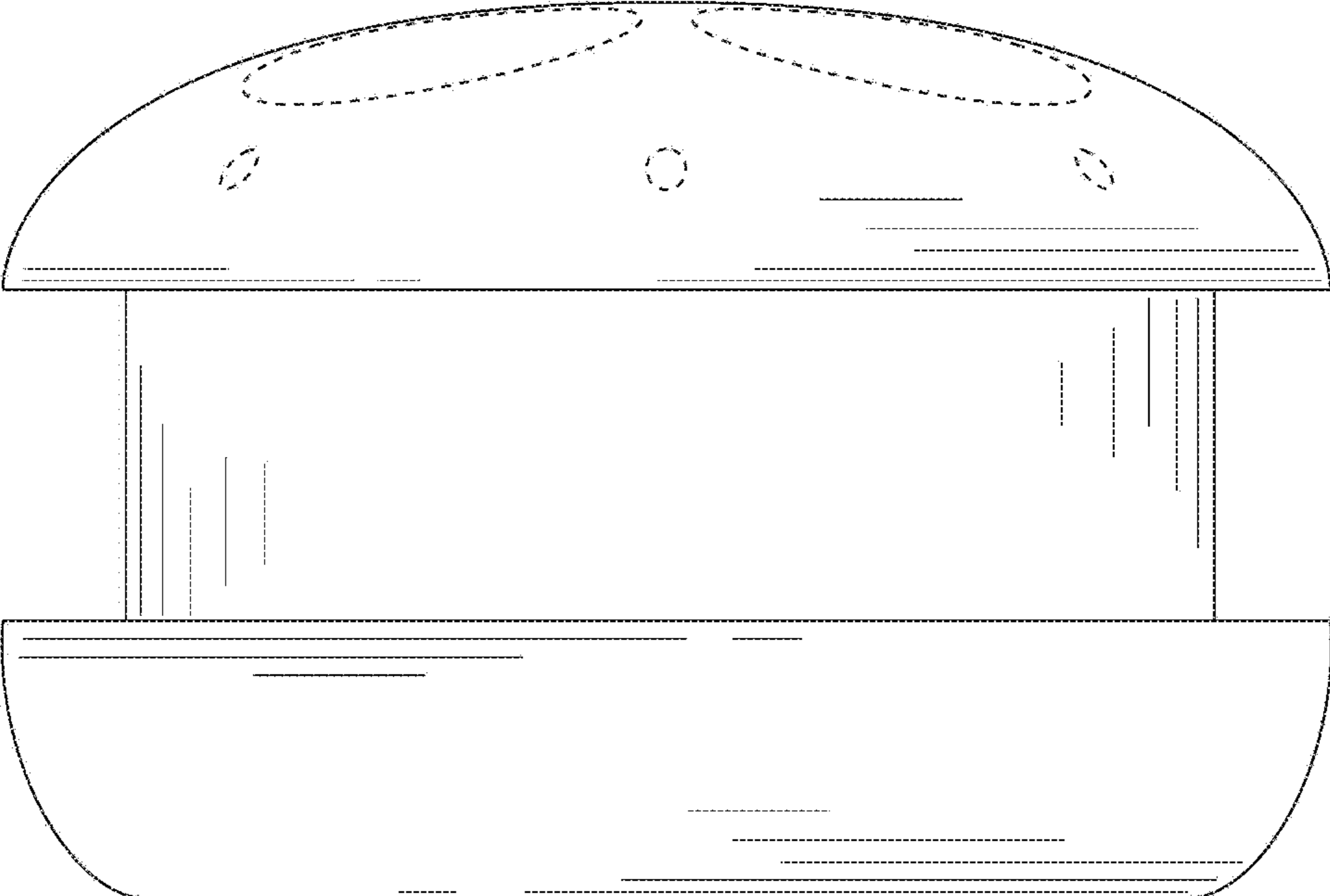

FIG. 4

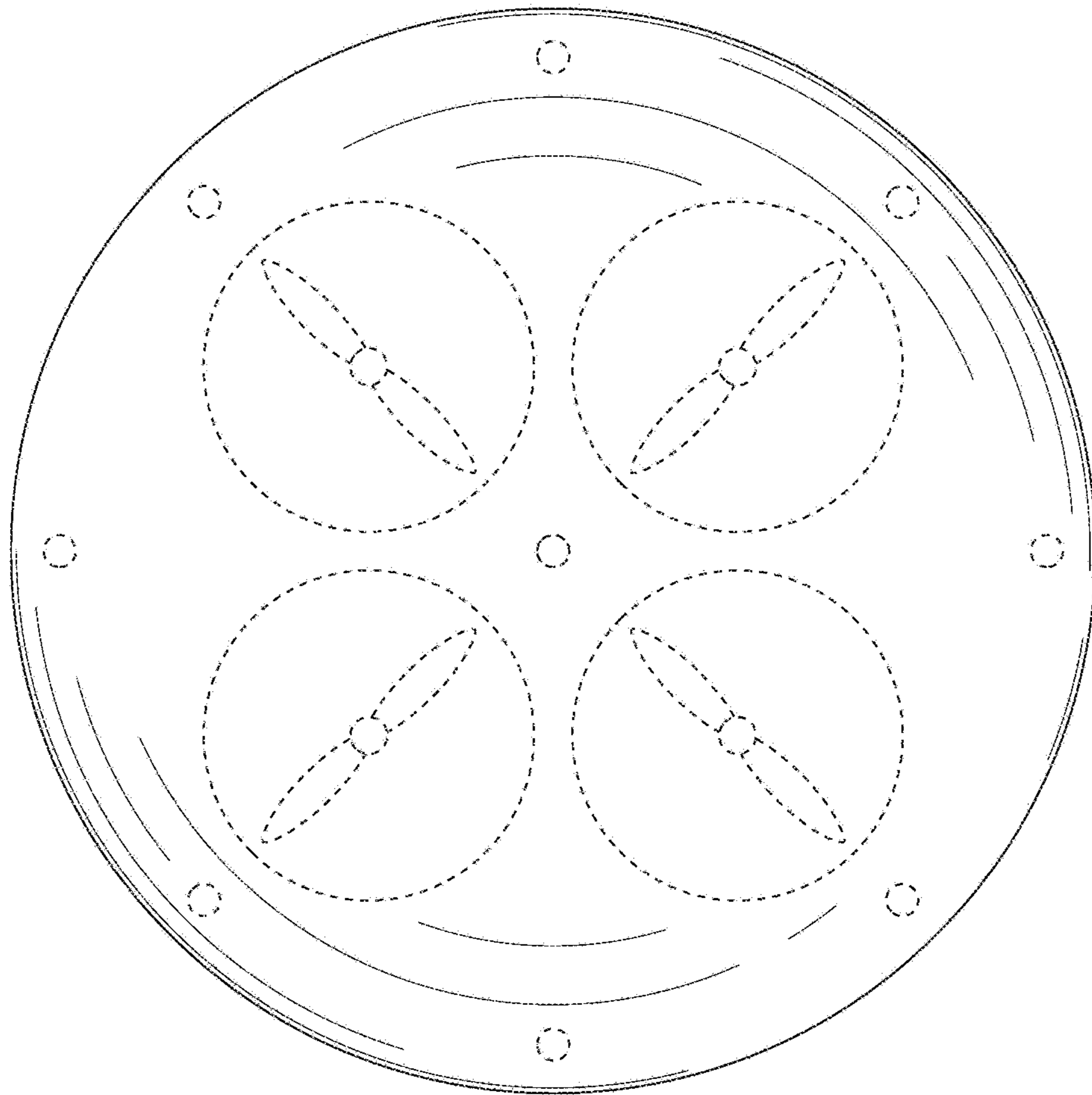

FIG. 5

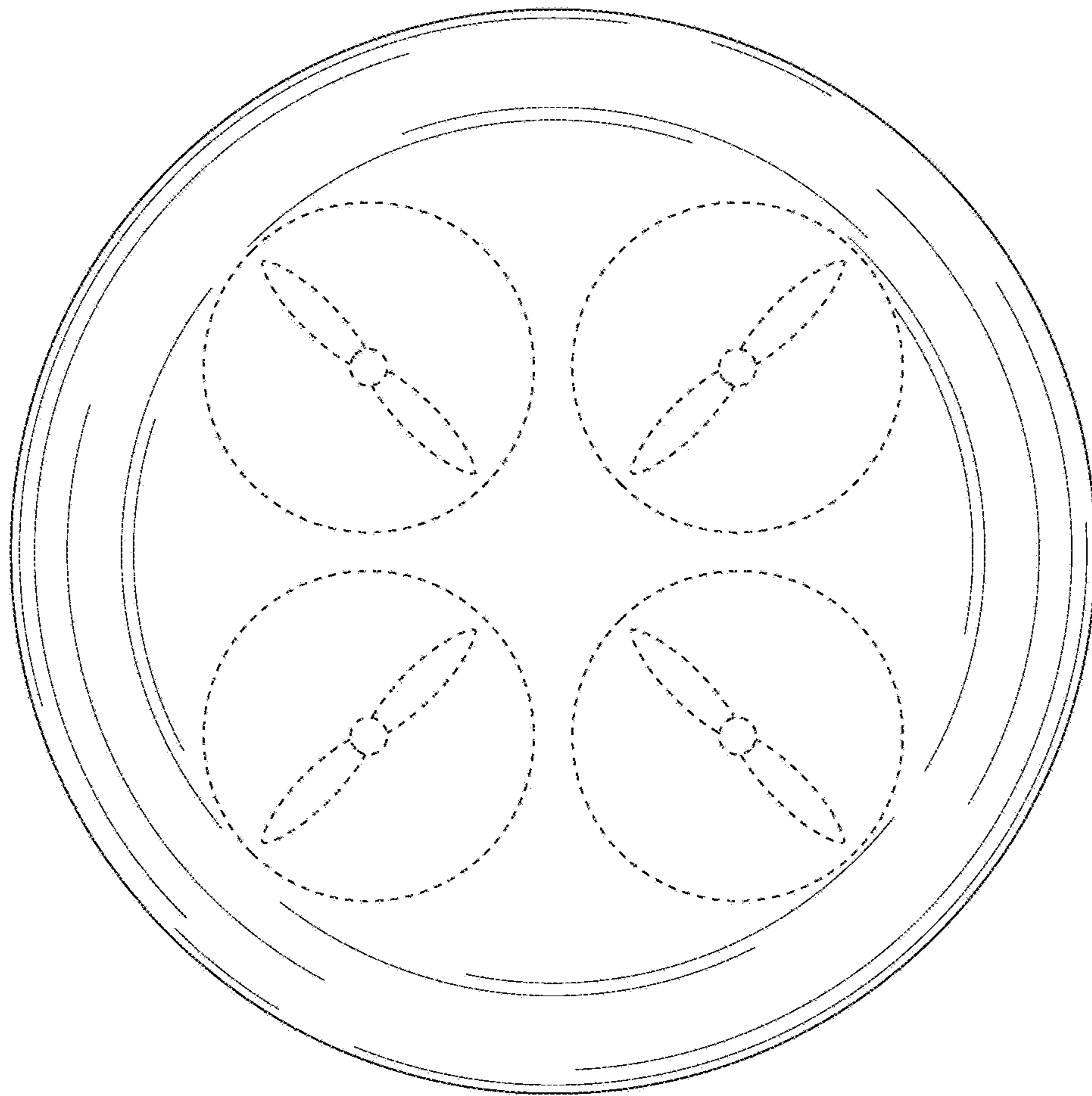

FIG. 6

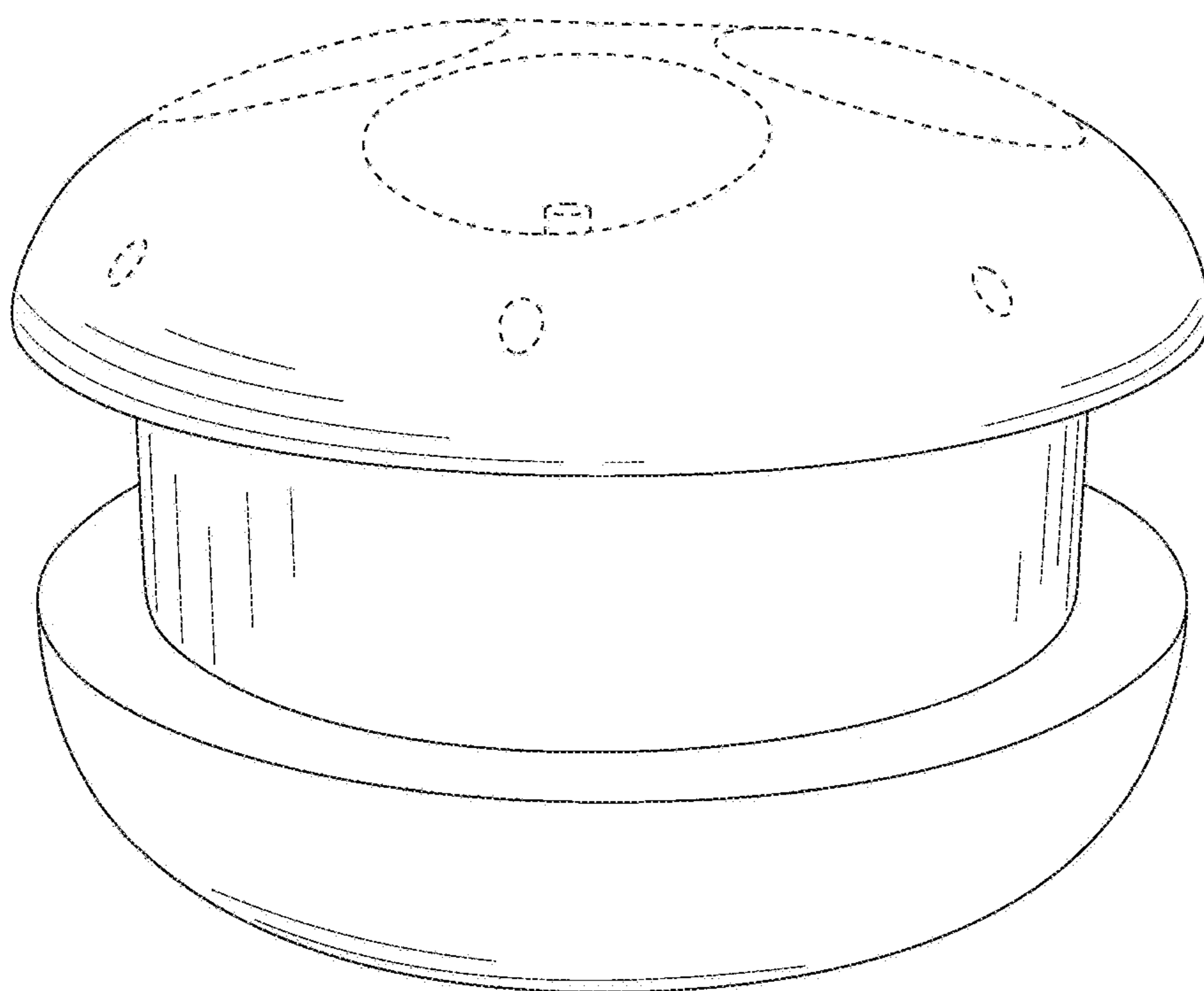

FIG. 7

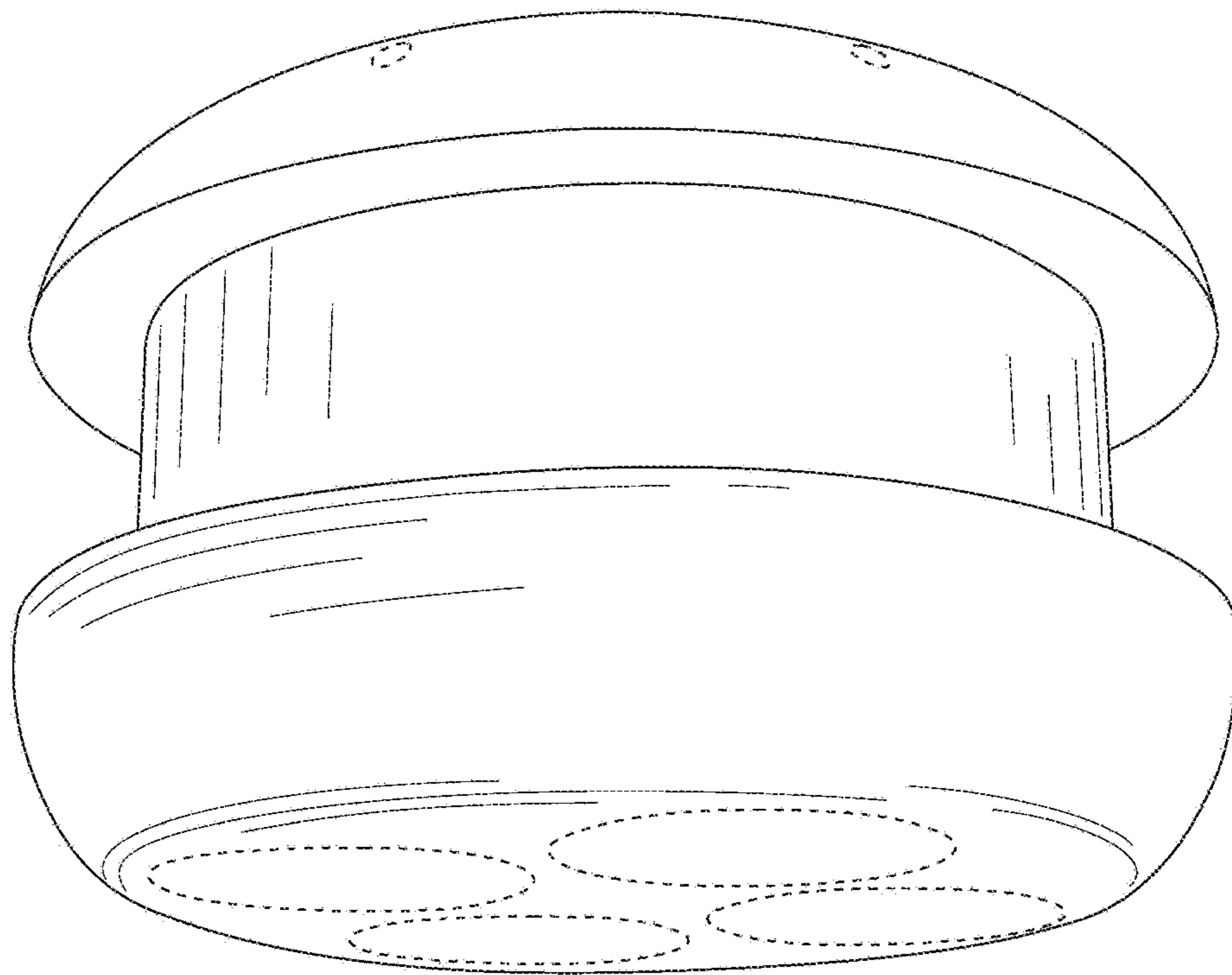

FIG. 8