



US00D869932S

(12) **United States Design Patent** (10) **Patent No.:** **US D869,932 S**  
**Kingsbury** (45) **Date of Patent:** **\*\* \*Dec. 17, 2019**

- (54) **BALL SAFETY LATCH LOCK**
- (71) Applicant: **Alan Kingsbury**, Campbellsville, KY (US)
- (72) Inventor: **Alan Kingsbury**, Campbellsville, KY (US)
- (\*) Notice: This patent is subject to a terminal disclaimer.
- (\*\*) Term: **15 Years**
- (21) Appl. No.: **29/624,195**
- (22) Filed: **Oct. 30, 2017**
- (51) **LOC (12) Cl.** ..... **08-07**
- (52) **U.S. Cl.**  
USPC ..... **D8/331**
- (58) **Field of Classification Search**  
USPC ..... D8/300–302, 330, 331, 334, 343, 346,  
D8/350; 292/348, 350, 357, 262, 277;  
70/20–22, 57, 57.1, 286–286, 314  
CPC ..... D05C 17/00; E05C 17/04; E05C 17/16;  
E05C 19/18; E05B 15/0205; E05B  
17/2023; E05B 47/00; E05B 1/00; E05B  
3/00  
See application file for complete search history.

(56) **References Cited**

U.S. PATENT DOCUMENTS

D319,775 S *	9/1991	MacFarlane	.....	D8/331
D600,999 S *	9/2009	Minnich	.....	D8/341
9,309,702 B2 *	4/2016	Hwang	.....	E05C 17/166
9,487,975 B2 *	11/2016	Daniels	.....	E05B 13/04
D775,929 S *	1/2017	Liau	.....	D8/331
D778,990 S *	2/2017	Kujawski	.....	D14/401
D784,986 S *	4/2017	Kujawski	.....	D14/401

2004/0007883 A1 *	1/2004	Laufer	.....	E05B 19/20 292/262
2005/0052035 A1 *	3/2005	Yamashita	.....	E05C 17/166 292/262
2014/0327251 A1 *	11/2014	Brinton	.....	E05C 17/166 292/277
2015/0097381 A1 *	4/2015	Hwang	.....	E05C 17/166 292/262
2016/0281398 A1 *	9/2016	Kingsbury	.....	E05C 17/166
2017/0335599 A1 *	11/2017	Casternovia	.....	E05B 17/2023
2018/0163445 A1 *	6/2018	Kingsbury	.....	E05C 17/166

\* cited by examiner

*Primary Examiner* — Ian Simmons

*Assistant Examiner* — Yolanda Robinson

(74) *Attorney, Agent, or Firm* — Francis Law Firm, PLLC; James M. Francis

(57) **CLAIM**

I claim the ornamental design for a ball safety latch lock, as shown and described.

**DESCRIPTION**

FIG. 1 is a right side anterior perspective view of a ball safety latch lock.

FIG. 2 is an anterior view of a ball safety latch lock.

FIG. 3 is a posterior view of a ball safety latch lock.

FIG. 4 is top view of a ball safety latch lock.

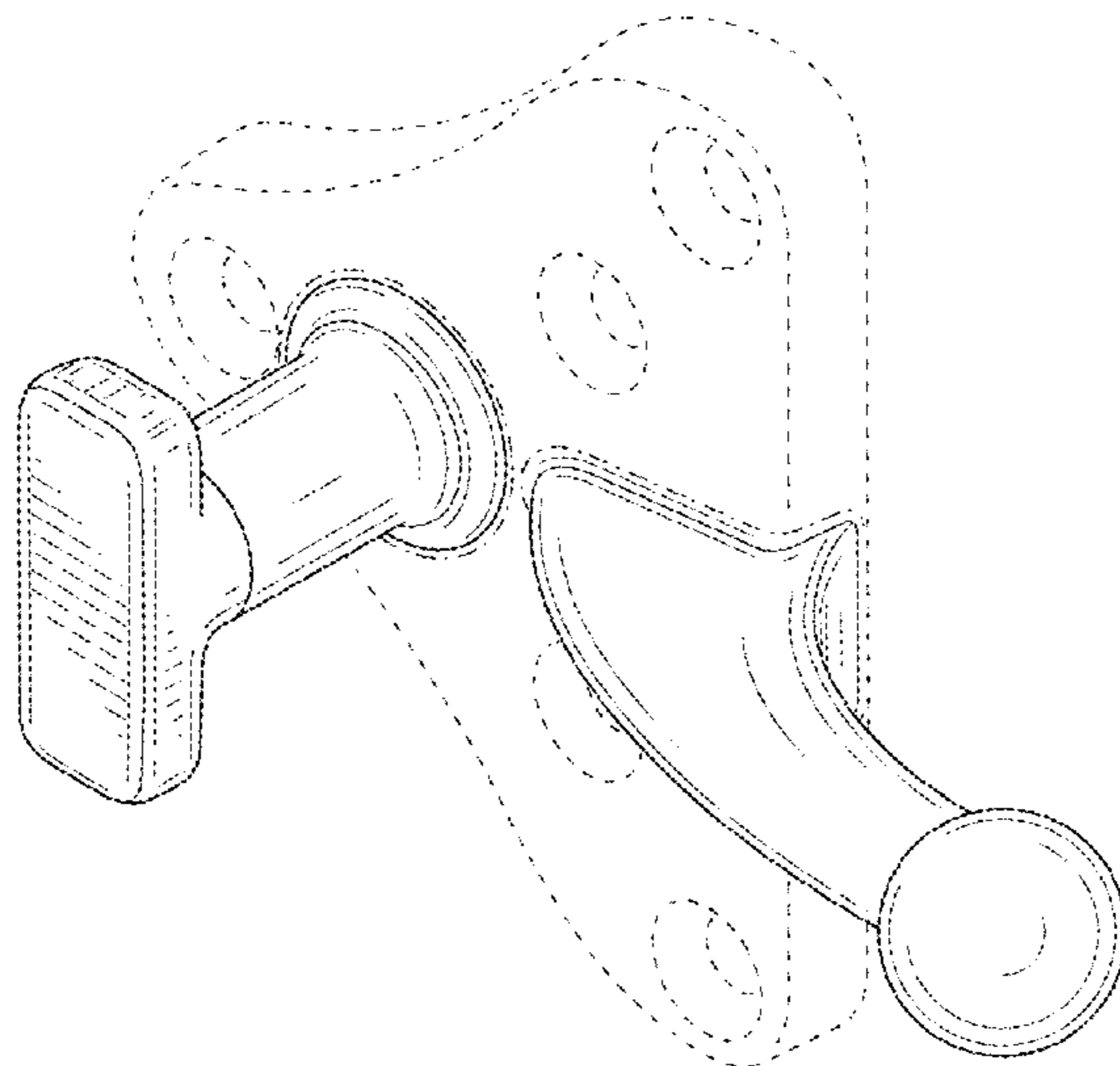
FIG. 5 is a bottom view of a ball safety latch lock.

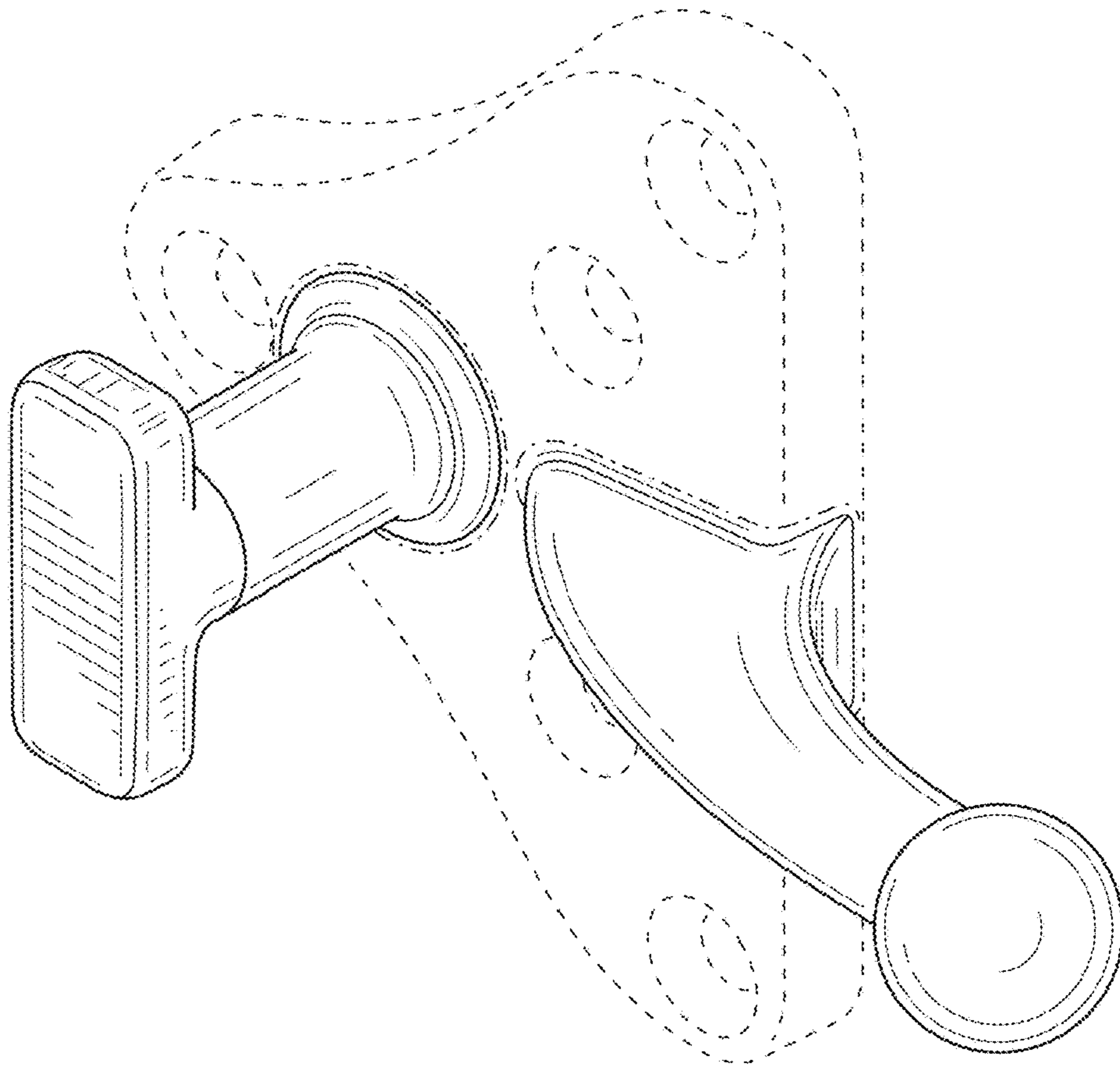
FIG. 6 is a left side view of a ball safety latch lock; and,

FIG. 7 is a right side view of a ball safety latch lock.

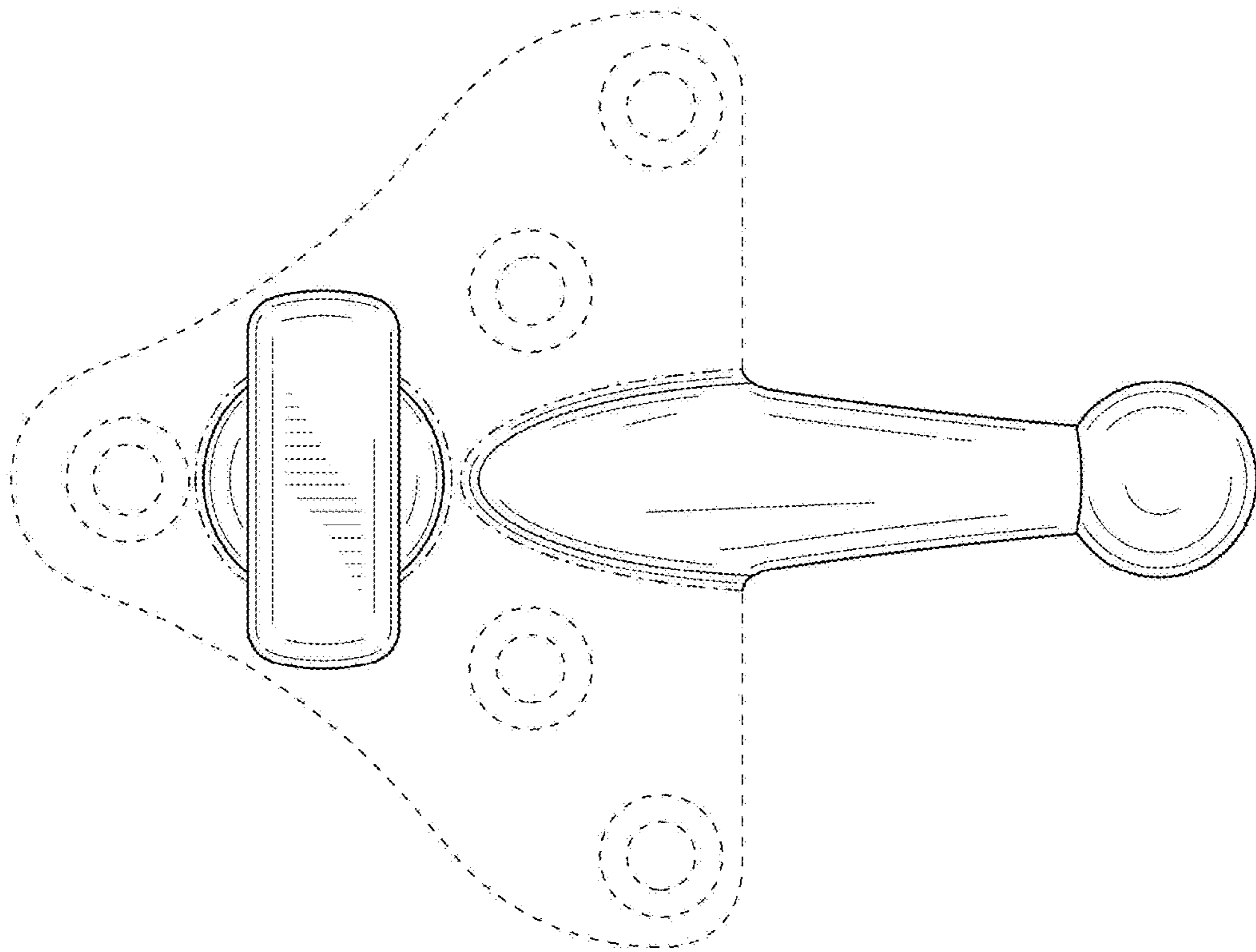
The dash dot dash lines shown in FIGS. 1-2, and 4-7 of the ball safety latch lock that are immediately adjacent to the claimed lines of the knob and latch features are the boundary of the design. The dash dash broken lines shown in FIGS. 1-7 are for the purpose of illustrating environment. None of the broken lines form any part of the claimed design.

**1 Claim, 6 Drawing Sheets**

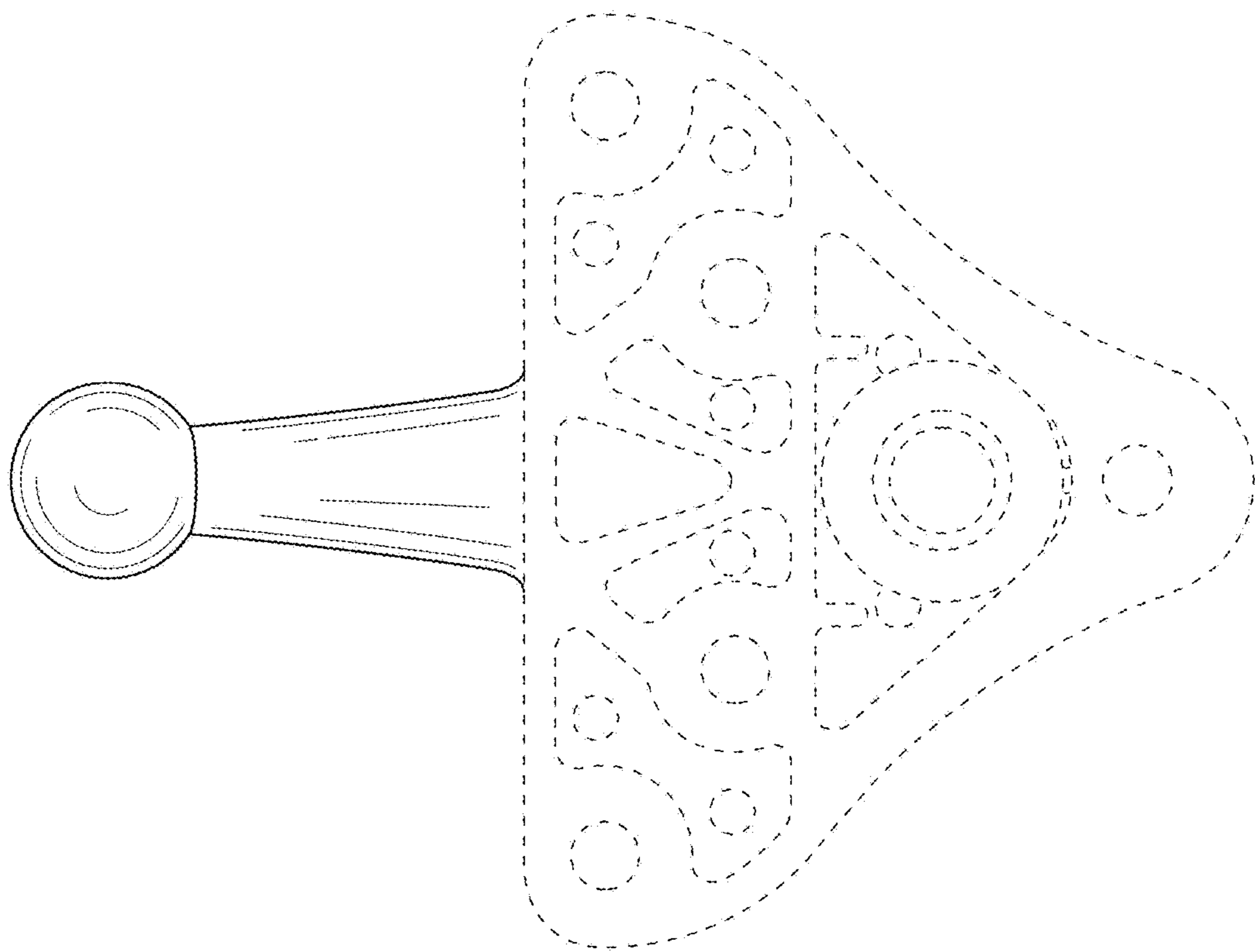




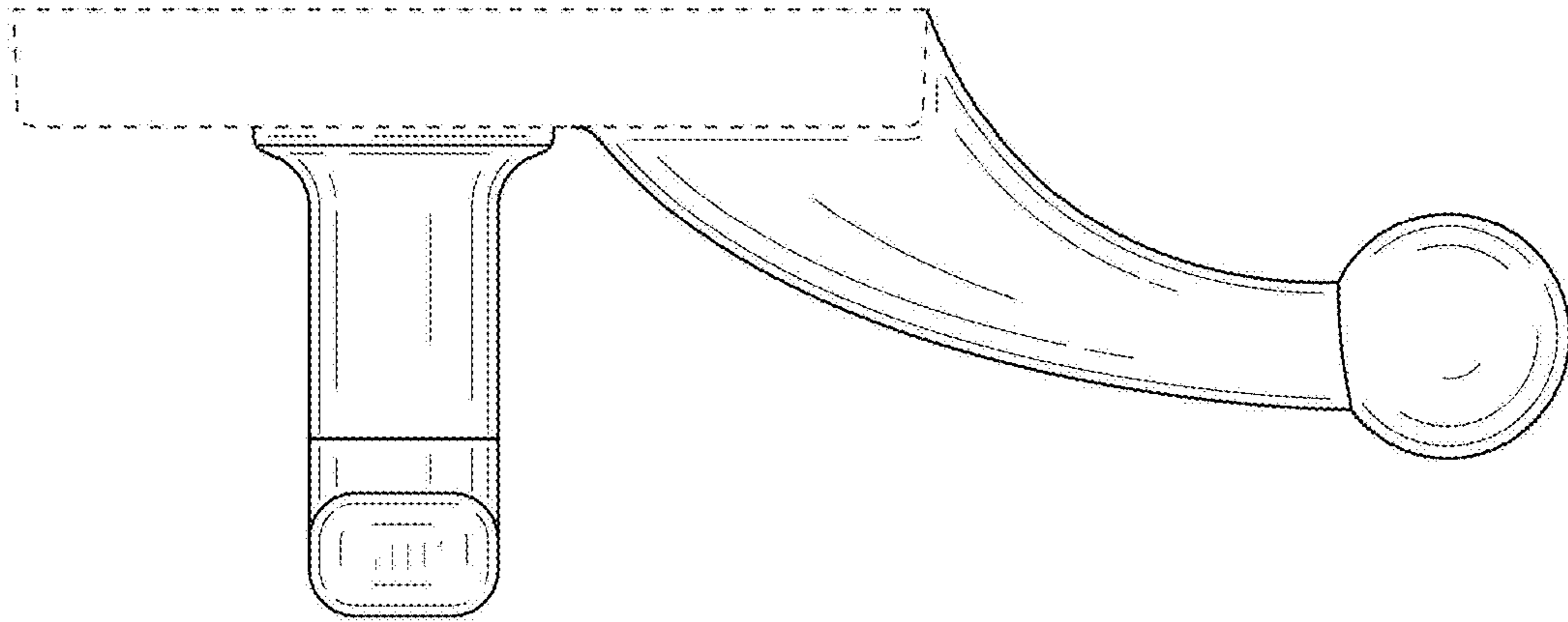
**FIG. 1**



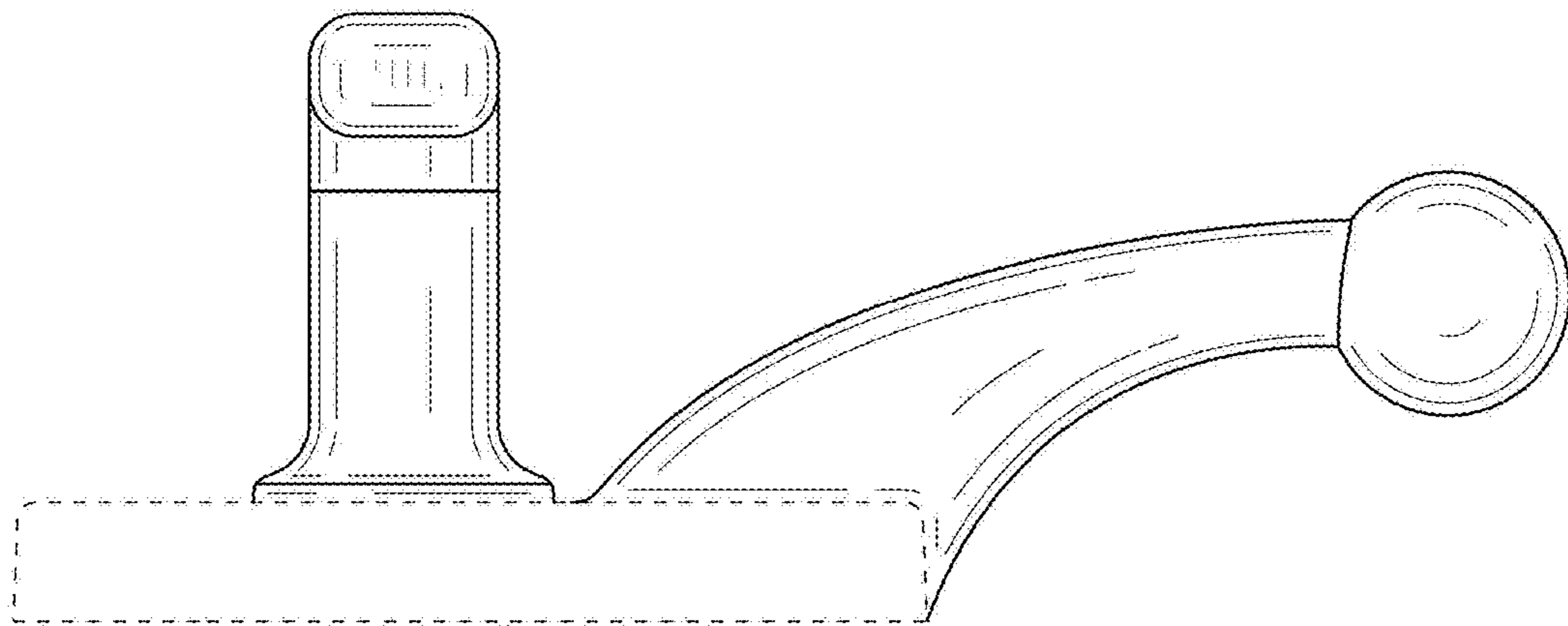
**FIG. 2**



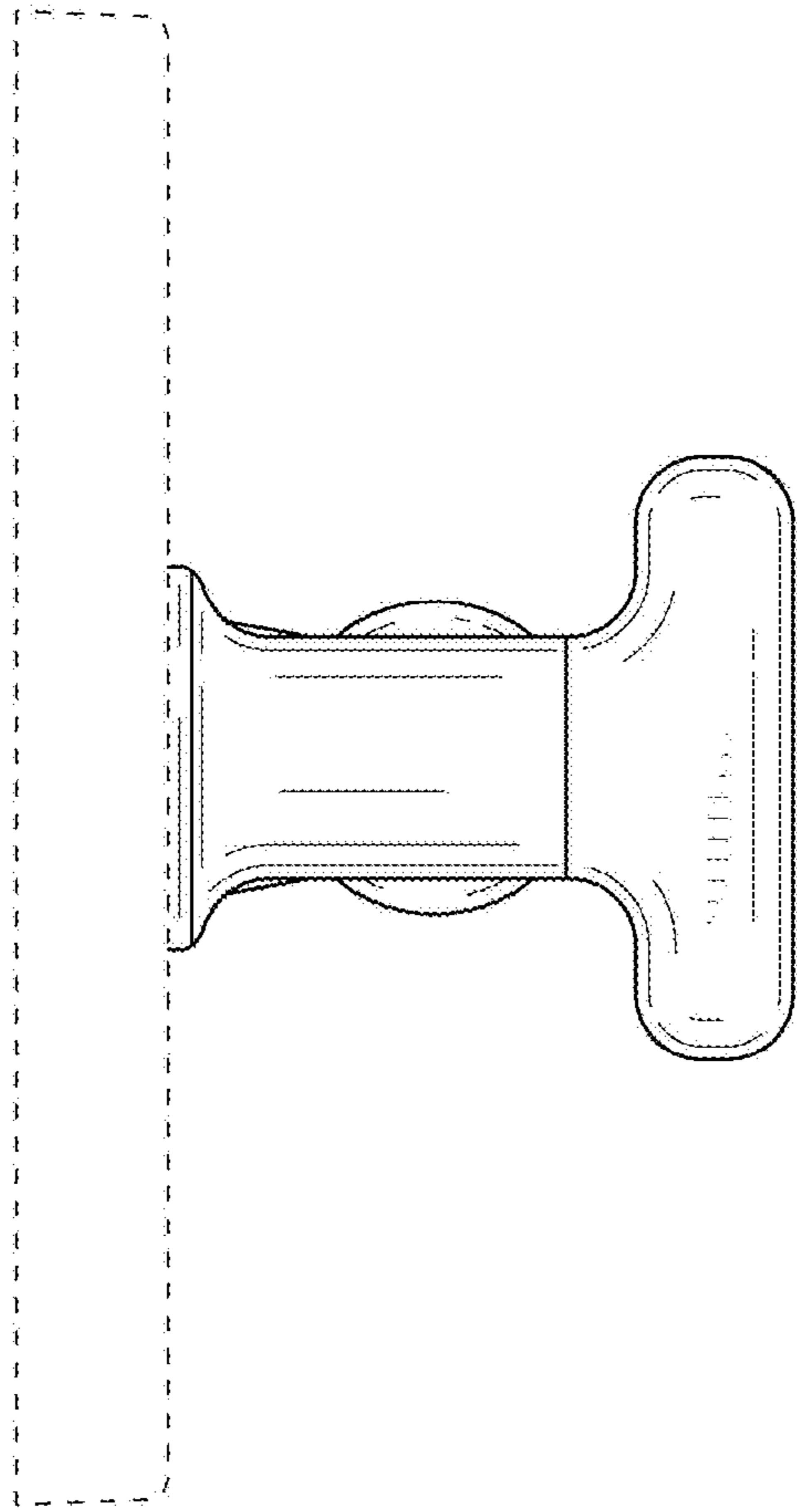
**FIG. 3**



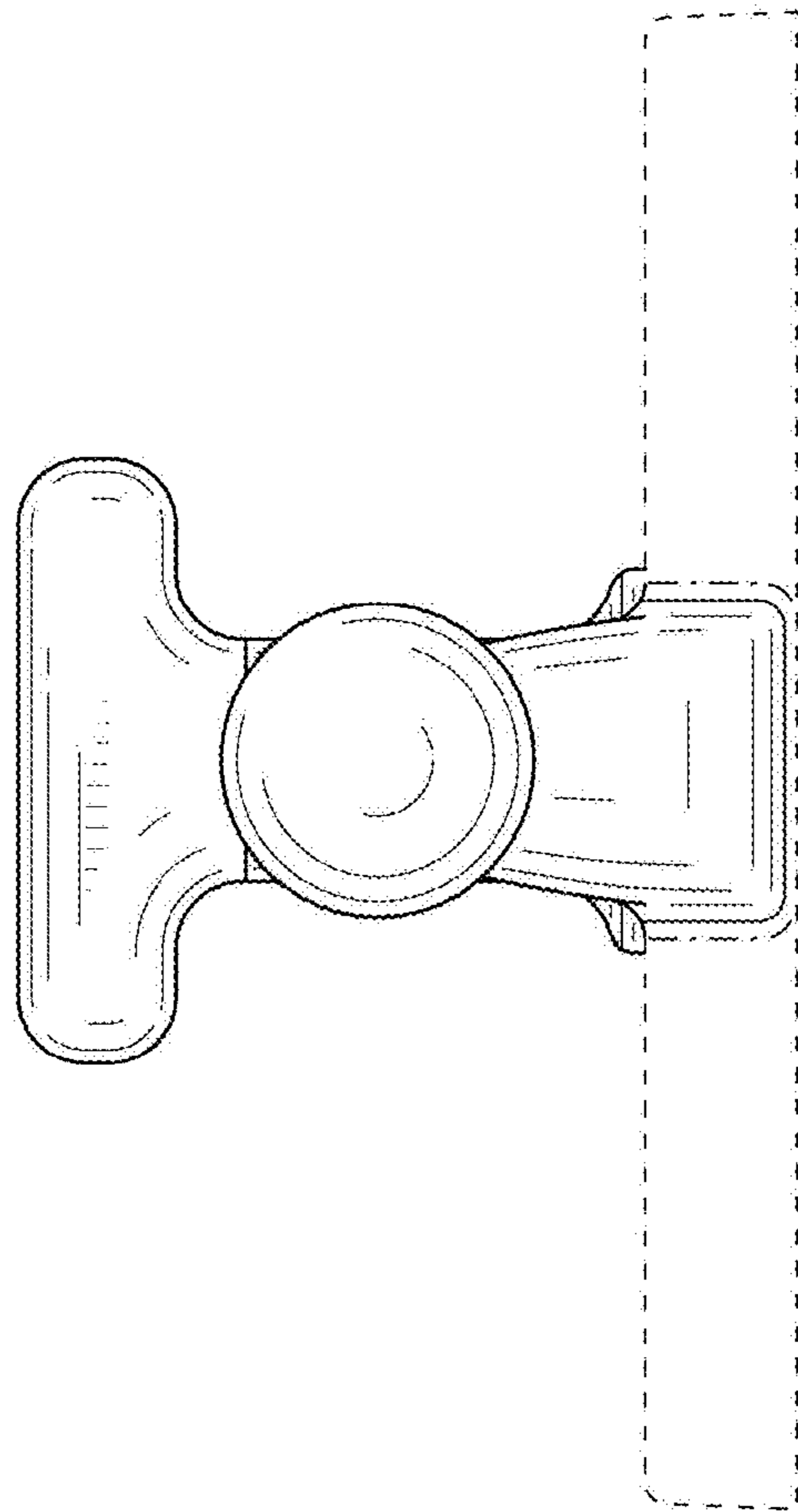
**FIG. 4**



**FIG. 5**



**FIG. 6**



**FIG. 7**