



US00D869885S

(12) **United States Design Patent** (10) **Patent No.:** **US D869,885 S**
Wilfer (45) **Date of Patent:** **** Dec. 17, 2019**

(54) **MULTIPLE GUITAR STAND**

(71) Applicant: **Warwick GmbH & Co. Music Equipment KG**, Markneukirchen (DE)

(72) Inventor: **Hans-Peter Wilfer**, Markneukirchen (DE)

(73) Assignee: **Warwick GmbH & Co. Music Equipment KG**, Markneukirchen (DE)

(**) Term: **15 Years**

(21) Appl. No.: **29/654,645**

(22) Filed: **Jun. 26, 2018**

(30) **Foreign Application Priority Data**

Jan. 19, 2018 (EM) 004672426

(51) **LOC (12) Cl.** **06-06**

(52) **U.S. Cl.**
USPC **D6/682.2**

(58) **Field of Classification Search**
USPC D6/672, 673, 682, 682.1, 682.2, 682.3, D6/682.4; D7/601; D17/20, 99
CPC G10G 5/00; G10G 7/00; G10G 7/005
See application file for complete search history.

(56) **References Cited**

U.S. PATENT DOCUMENTS

D278,670 S * 5/1985 Schoenig D6/681.1
D295,814 S * 5/1988 Chang D6/682
D319,926 S * 9/1991 Solomon D6/312
D333,770 S * 3/1993 Jureckson D8/71
5,556,064 A * 9/1996 Cowe F16M 11/24
248/172
D375,834 S * 11/1996 Meisner D3/274

(Continued)

Primary Examiner — Kelley A Donnelly

(74) *Attorney, Agent, or Firm* — Scarinci Hollenbeck, LLC; Libby Babu Varghese

(57) **CLAIM**

The ornamental design for a multiple guitar stand, as shown and described.

DESCRIPTION

FIG. 1 is a perspective view of a multiple guitar stand in the extended position;
FIG. 2 is a left-side view of a multiple guitar stand in the extended position;
FIG. 3 is a right-side view of a multiple guitar stand in the extended position;
FIG. 4 is a top view of a multiple guitar stand in the extended position;
FIG. 5 is a back view of a multiple guitar stand in the extended position;
FIG. 6 is a front view of a multiple guitar stand in the extended position;
FIG. 7 is a bottom view of a multiple guitar stand in the extended position;
FIG. 8 is a perspective view of a multiple guitar stand in the retracted position;
FIG. 9 is a left-view of a multiple guitar stand in the retracted position;
FIG. 10 is a right-view of a multiple guitar stand in the retracted position;
FIG. 11 is a top view of a multiple guitar stand in the retracted position;
FIG. 12 is a back view of a multiple guitar stand in the retracted position;
FIG. 13 is a front view of a multiple guitar stand in the retracted position; and,
FIG. 14 is a bottom view of a multiple guitar stand in the retracted position.

The elements shown in broken lines do not form any part of the claimed design. The break lines shown in FIGS. 1, 4, 5, 6, 7, 8, 11, 12, 13, and 14 are not part of the claimed design and represent that no particular length is claimed.

1 Claim, 14 Drawing Sheets

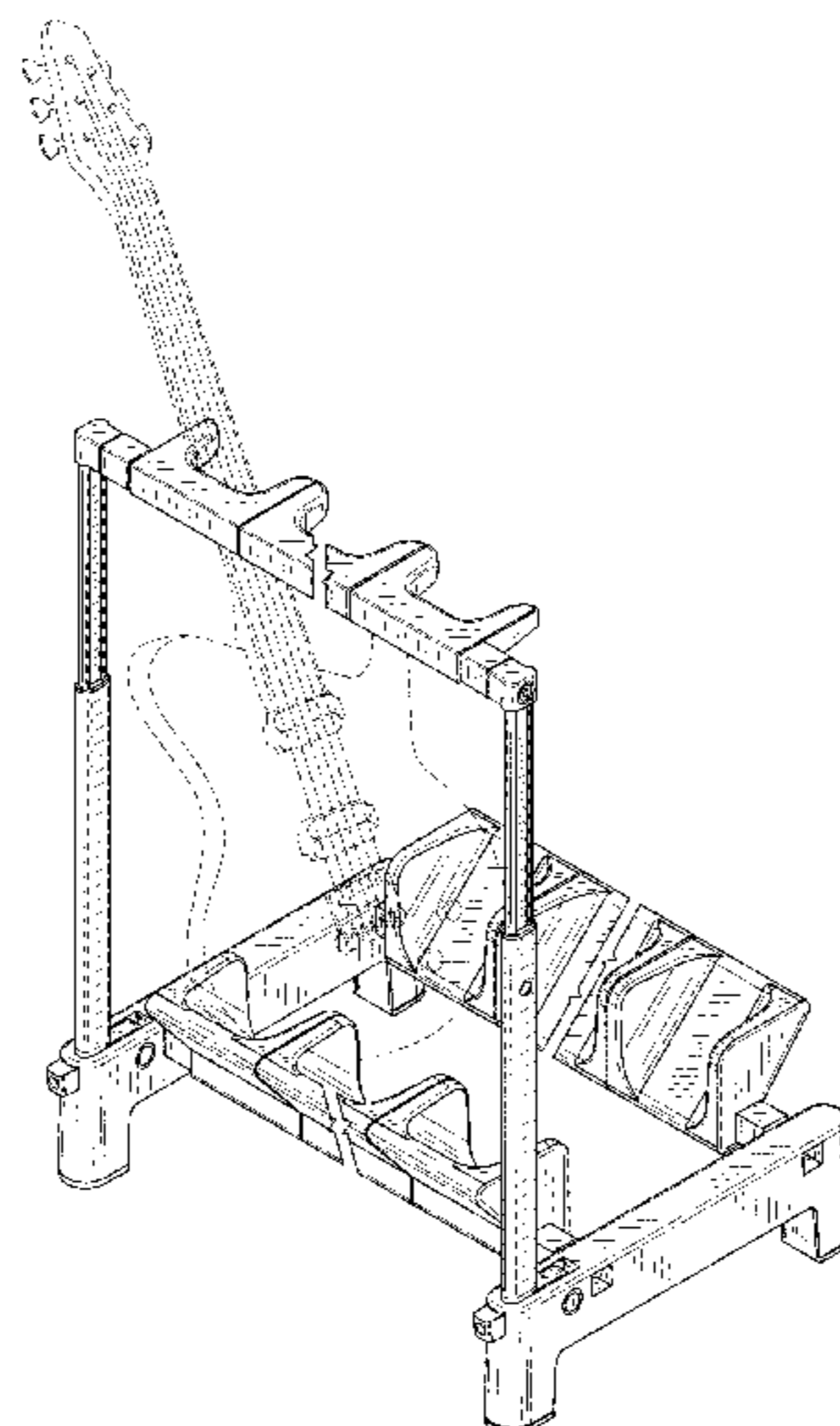

(56)

References Cited

U.S. PATENT DOCUMENTS

D538,554 S	*	3/2007	Tai	D6/682
D648,572 S	*	11/2011	Werner	D6/682.4
D675,039 S	*	1/2013	Foisy	D6/682.1
D679,117 S	*	4/2013	Werner	D6/682.4
D702,065 S	*	4/2014	Moore	D6/682.4
D756,692 S	*	5/2016	Hallett	D6/682.4
D806,188 S	*	12/2017	Petek	D21/686
D807,447 S	*	1/2018	Meredith	D21/691

* cited by examiner

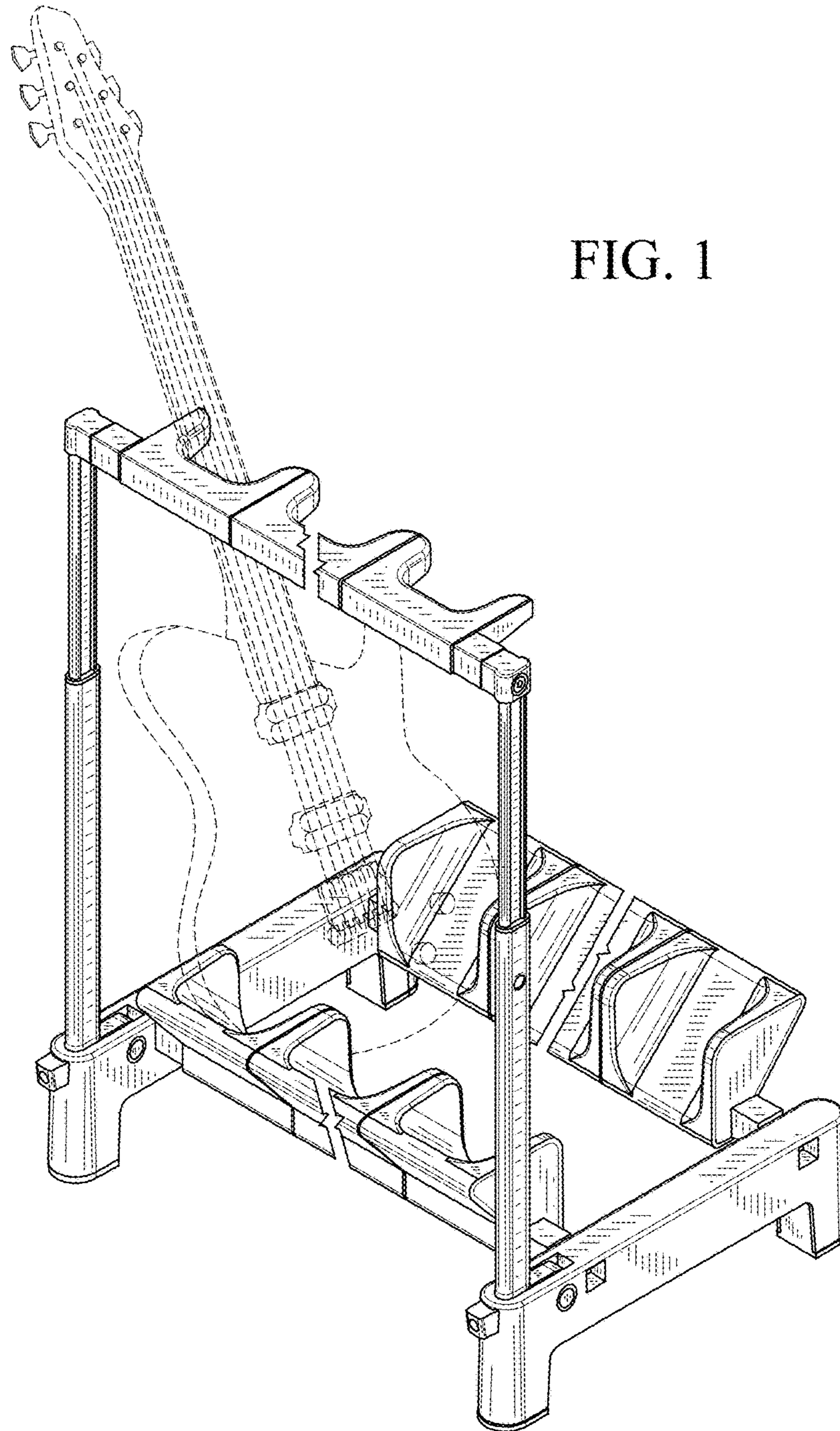

FIG. 1

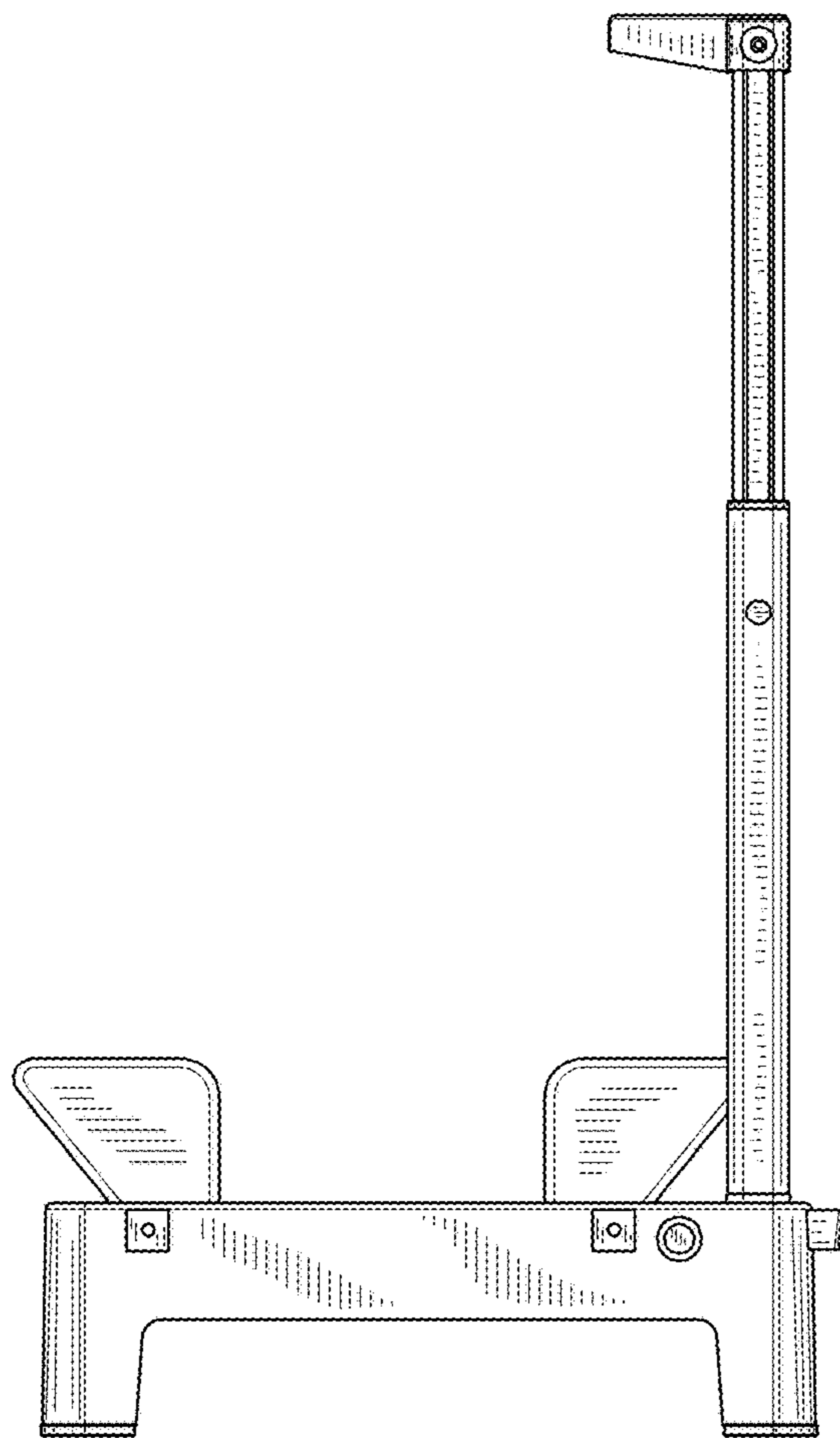

FIG. 2

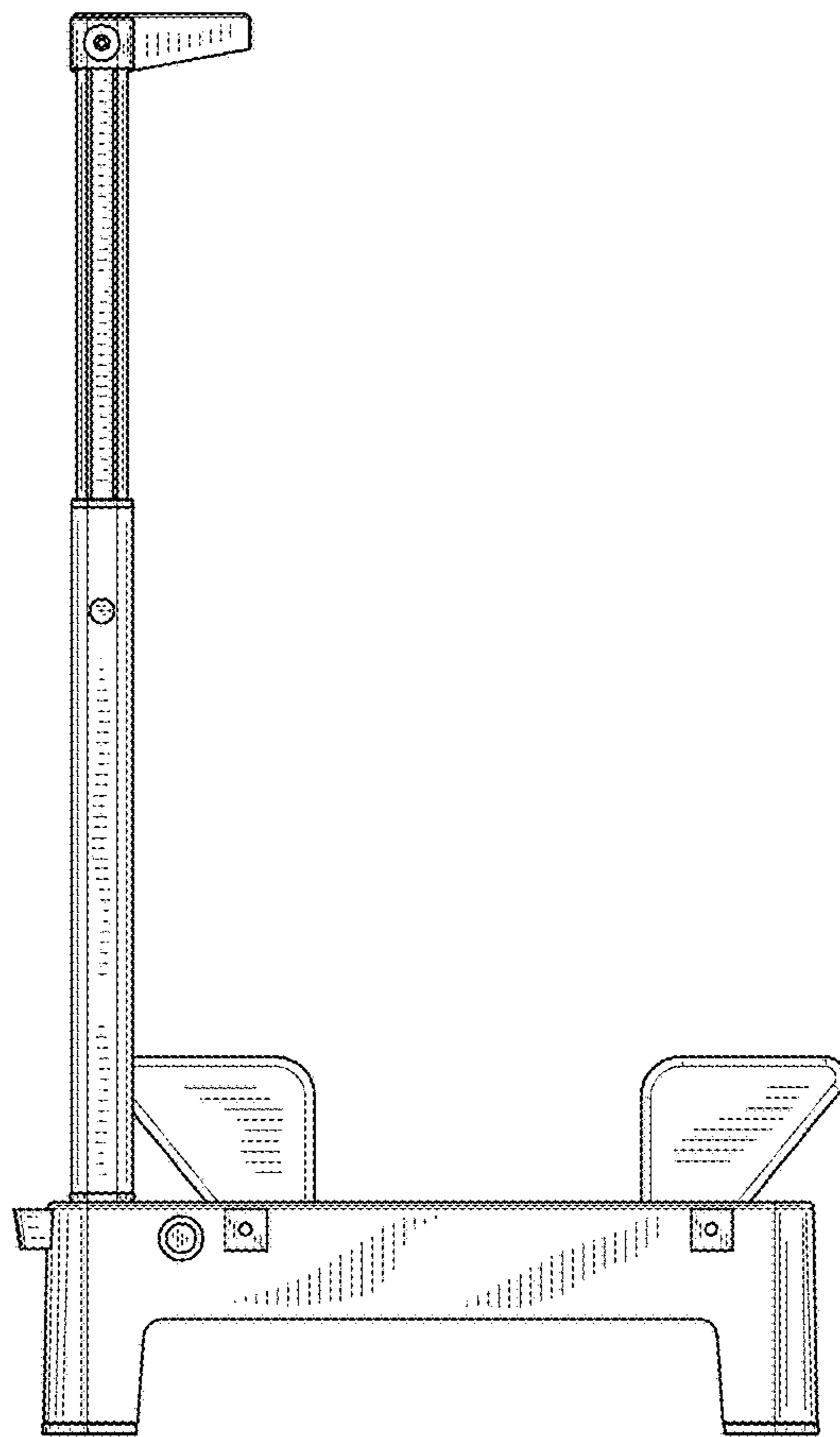

FIG. 3

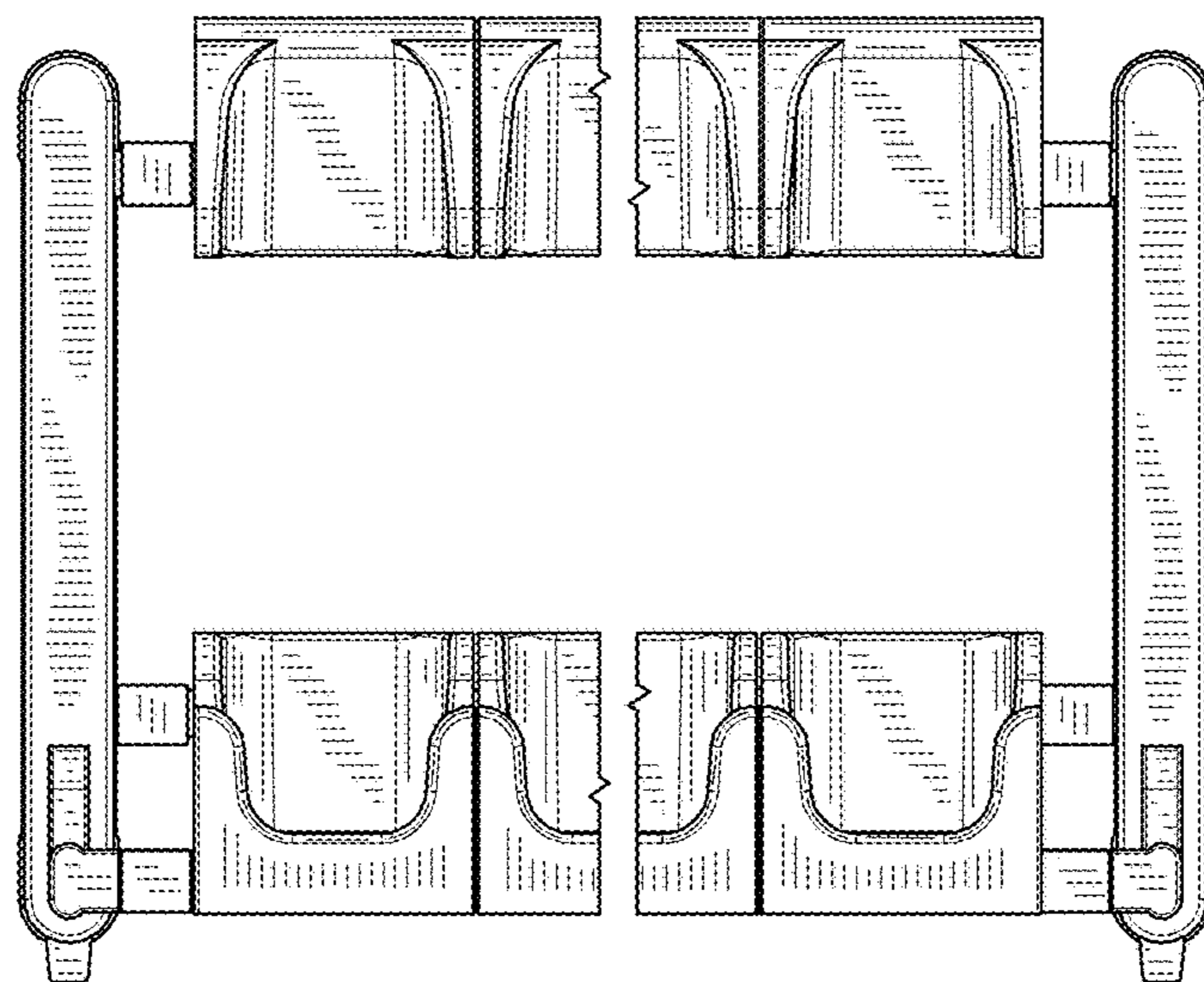

FIG. 4

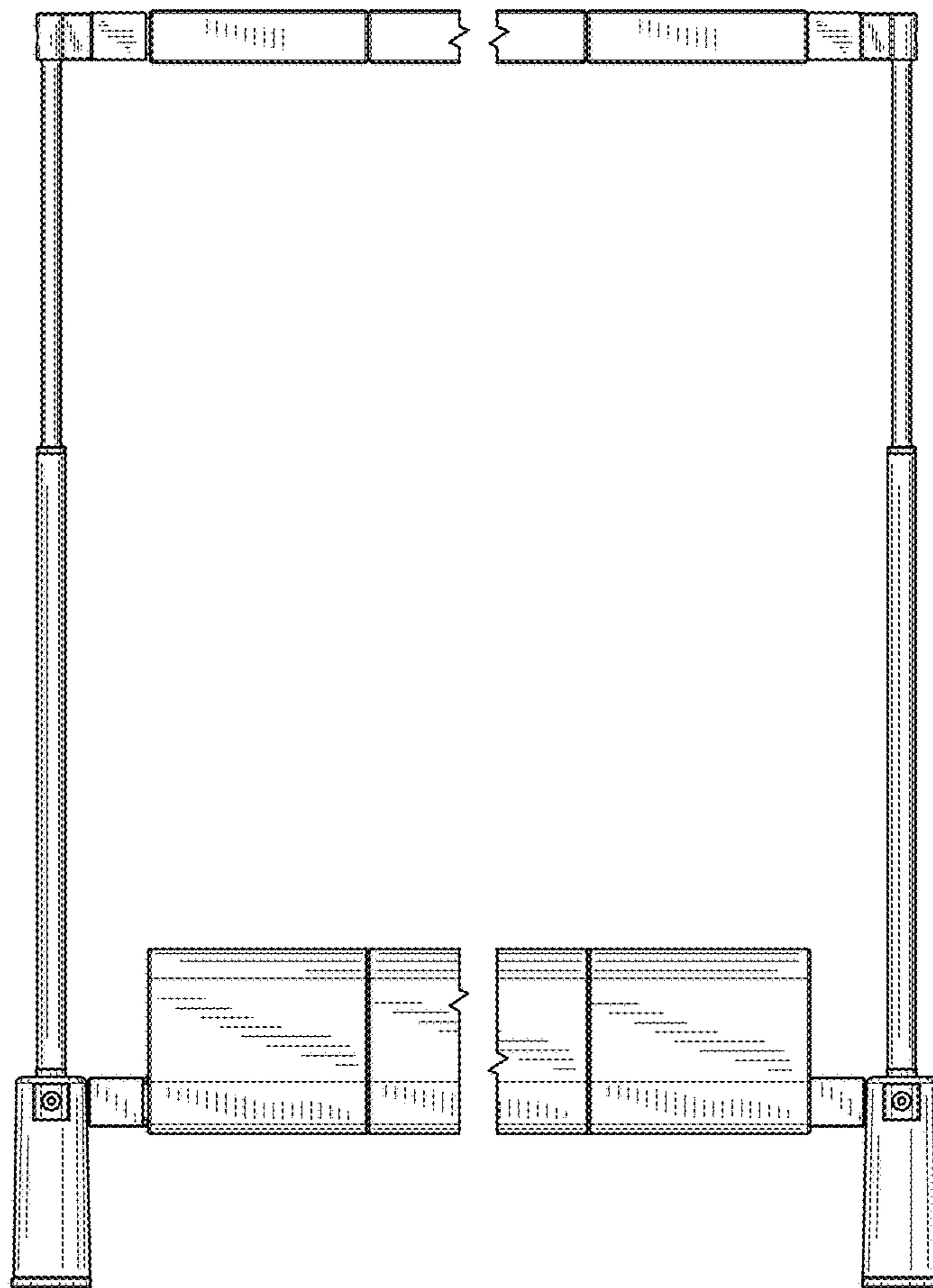

FIG. 5

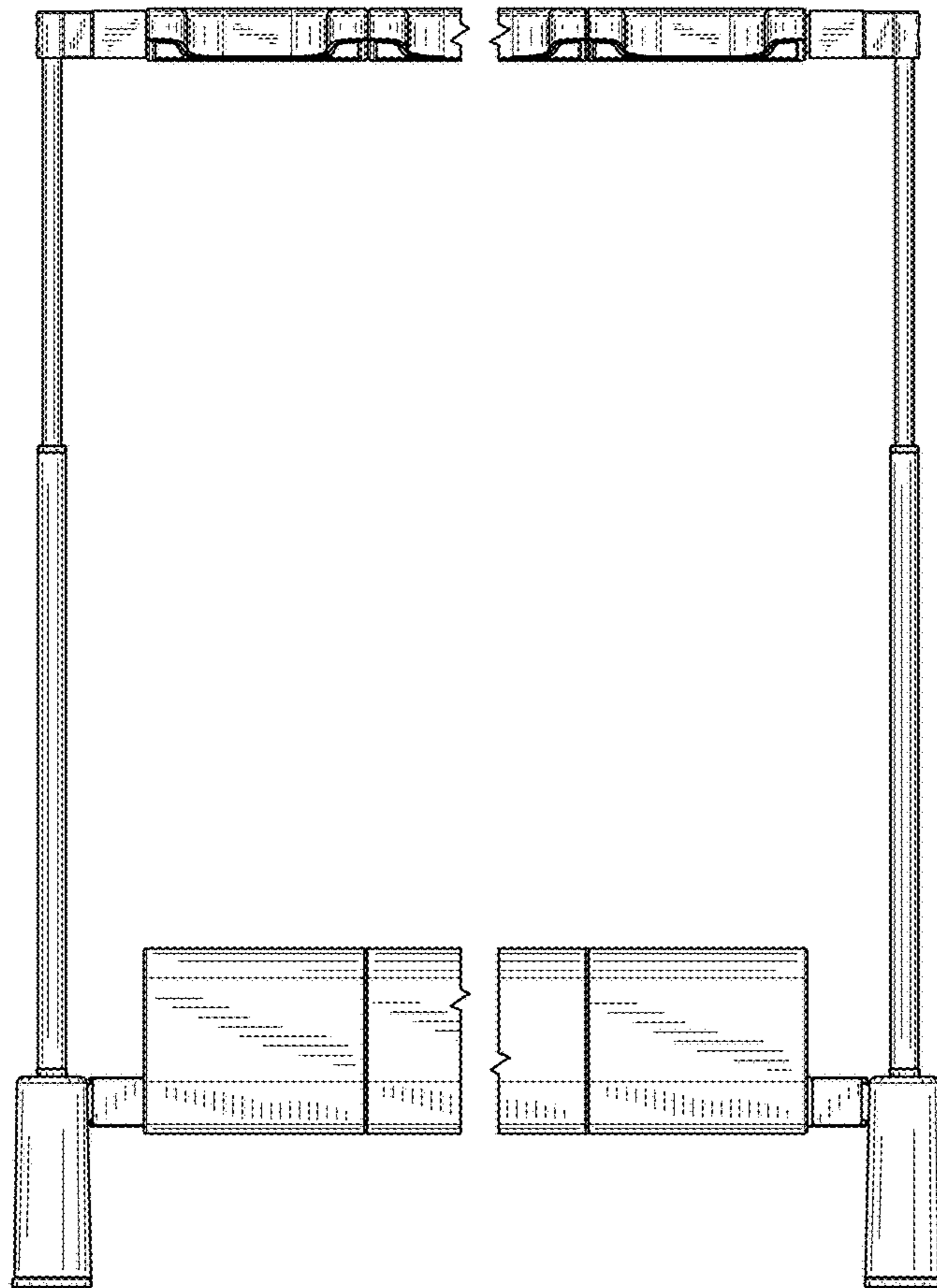

FIG. 6

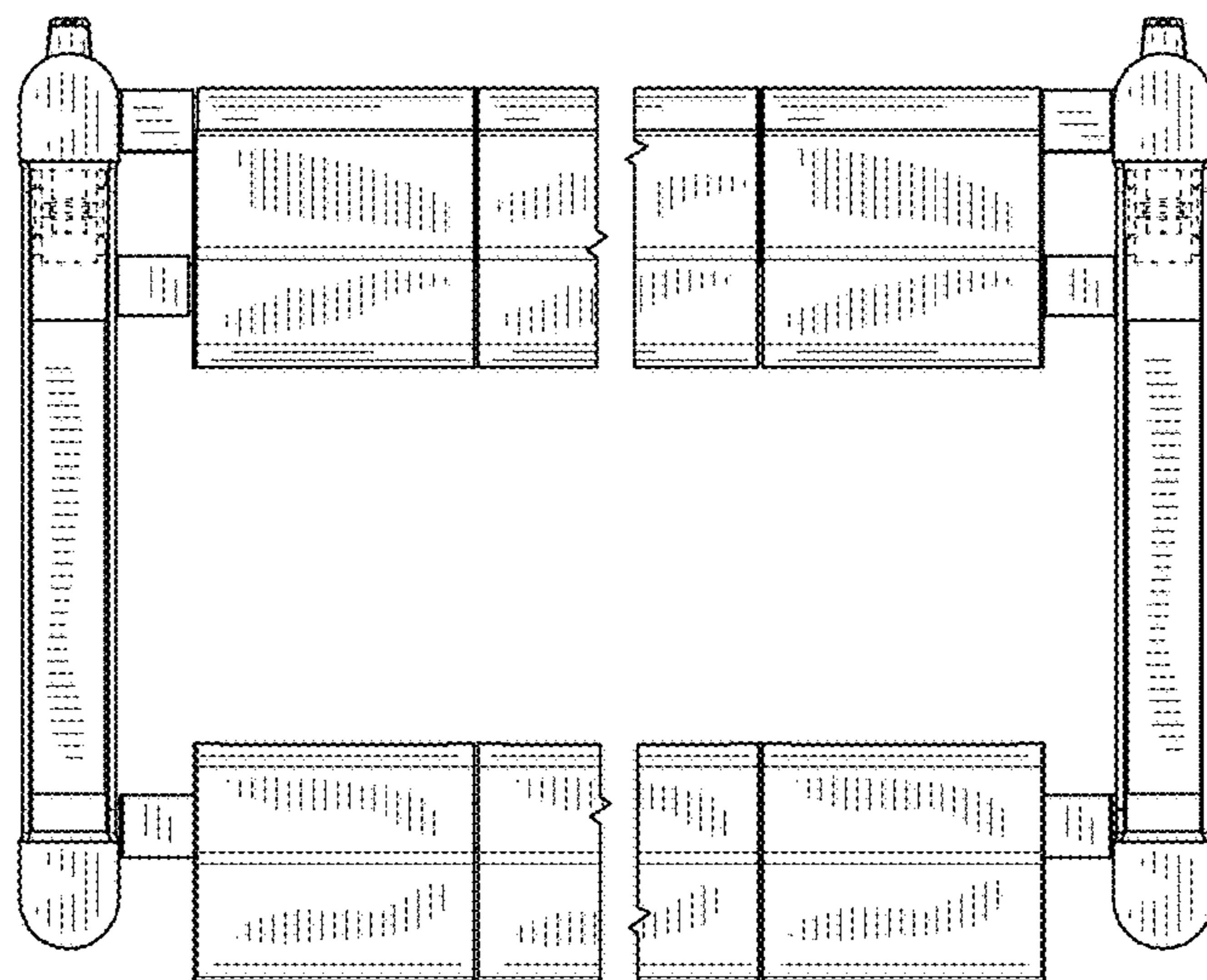

FIG. 7

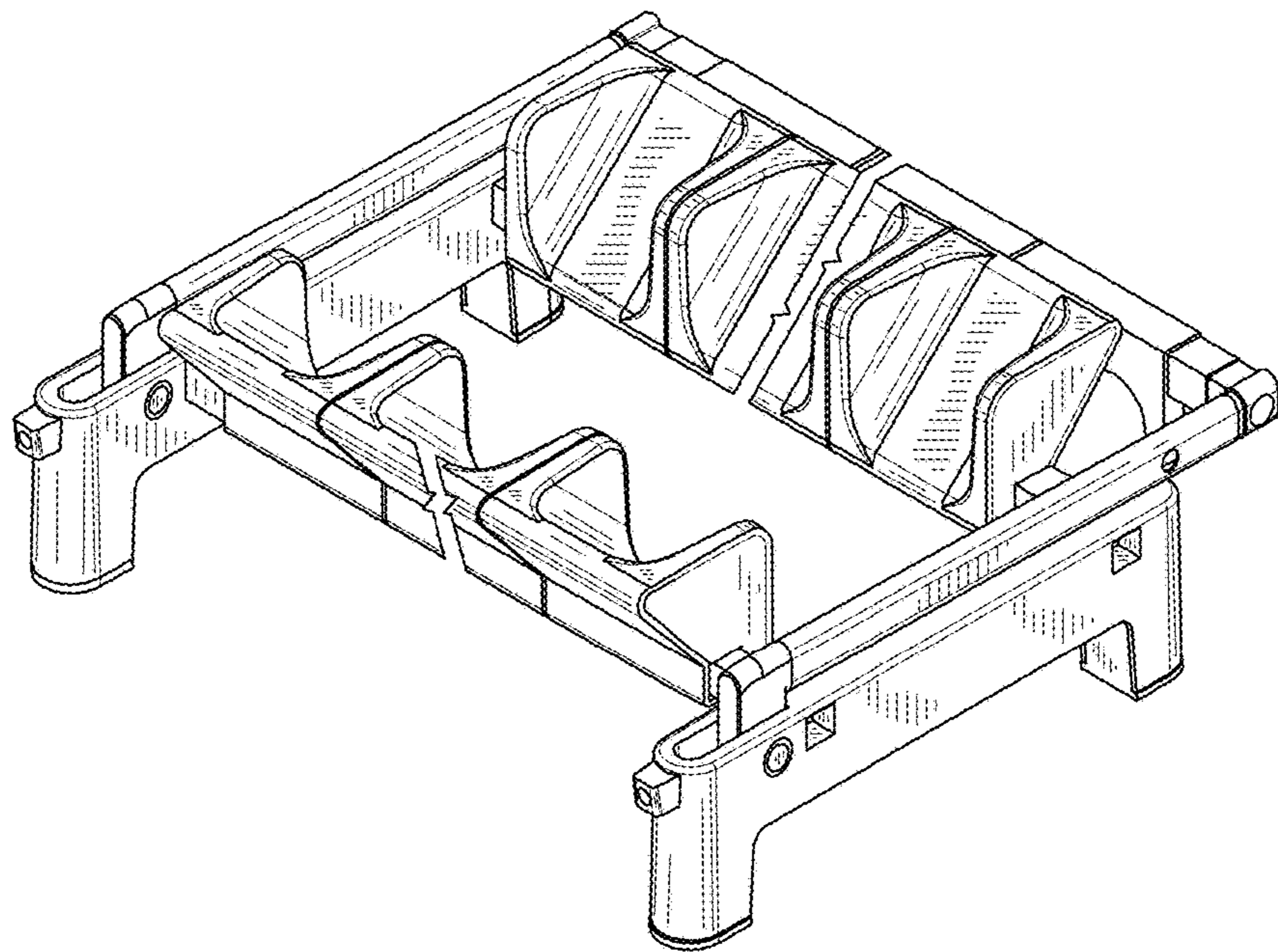

FIG. 8

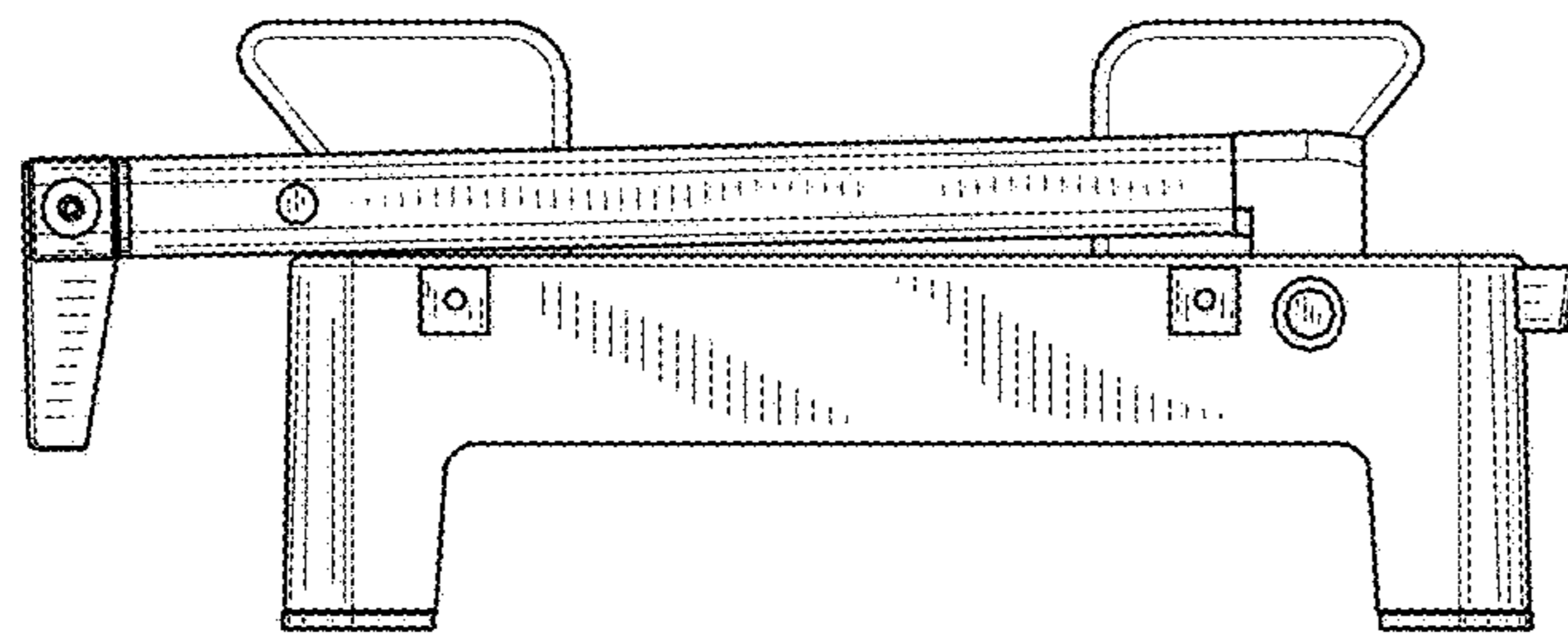

FIG. 9

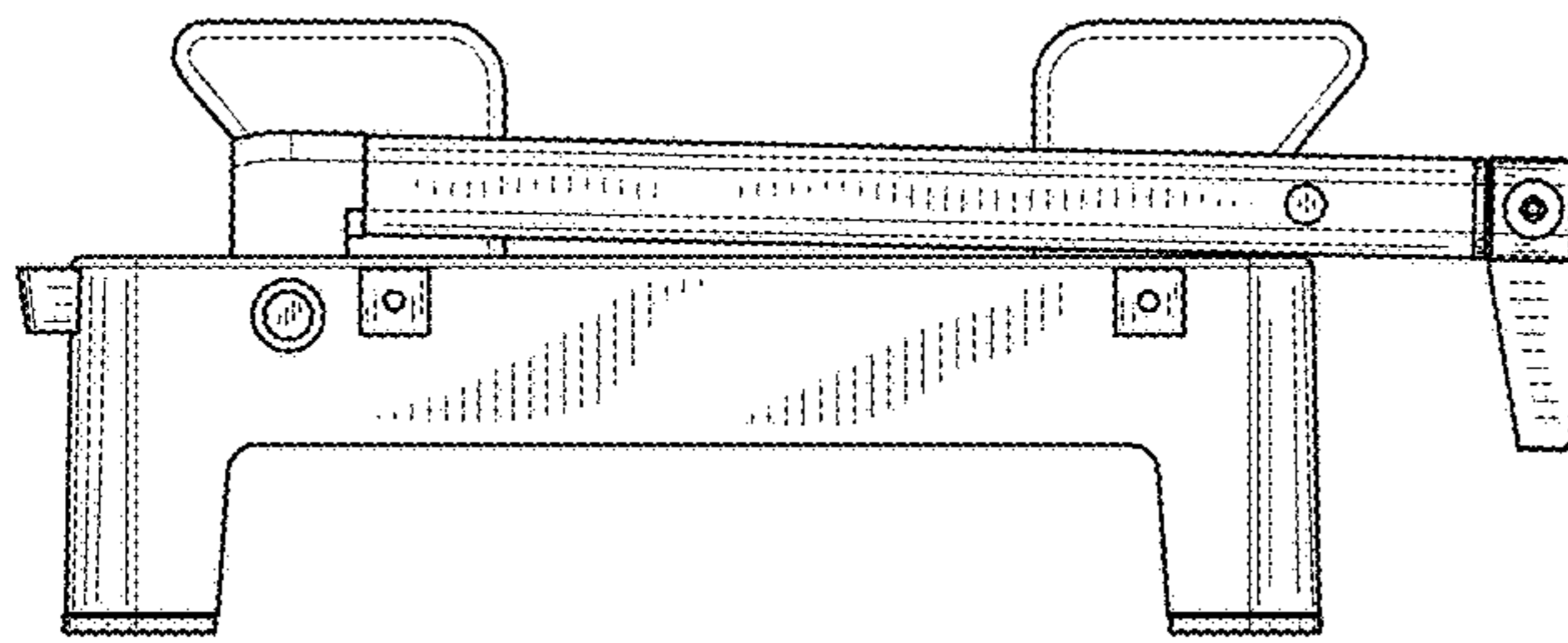

FIG. 10

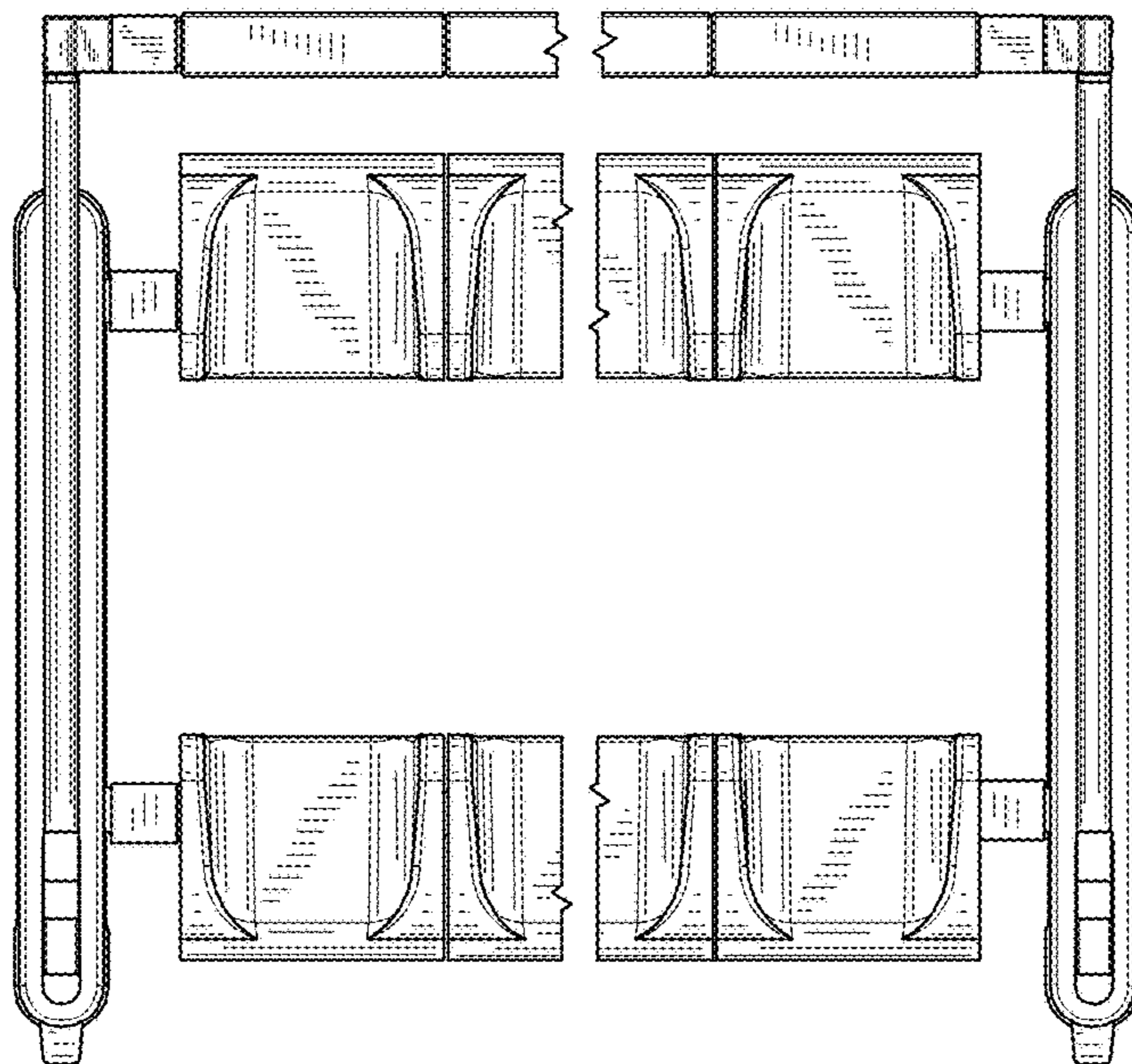

FIG. 11

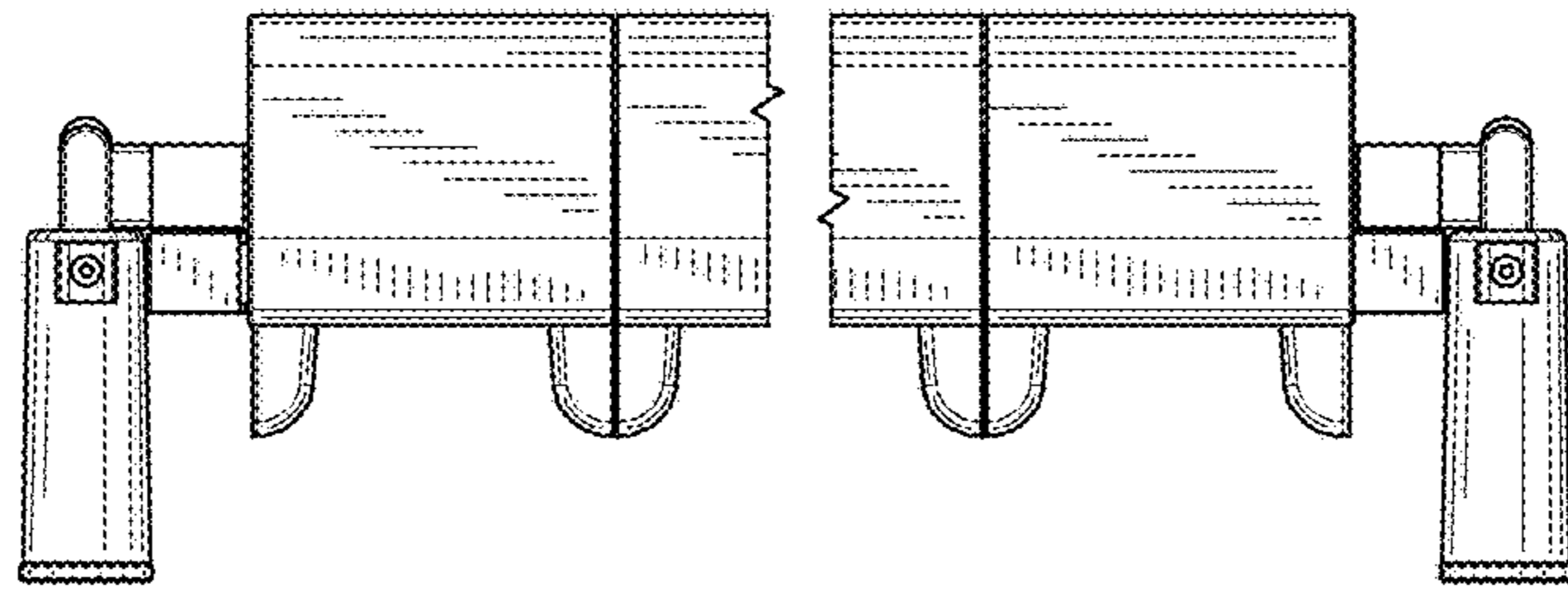

FIG. 12

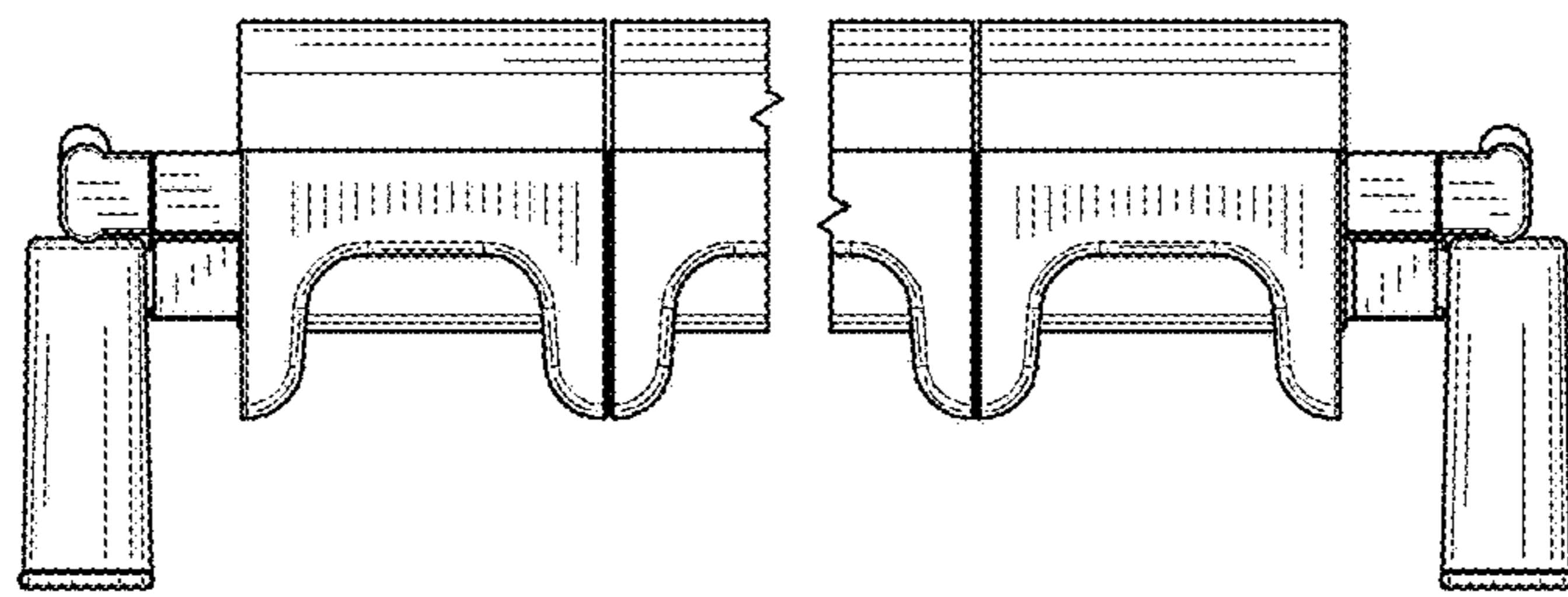

FIG. 13

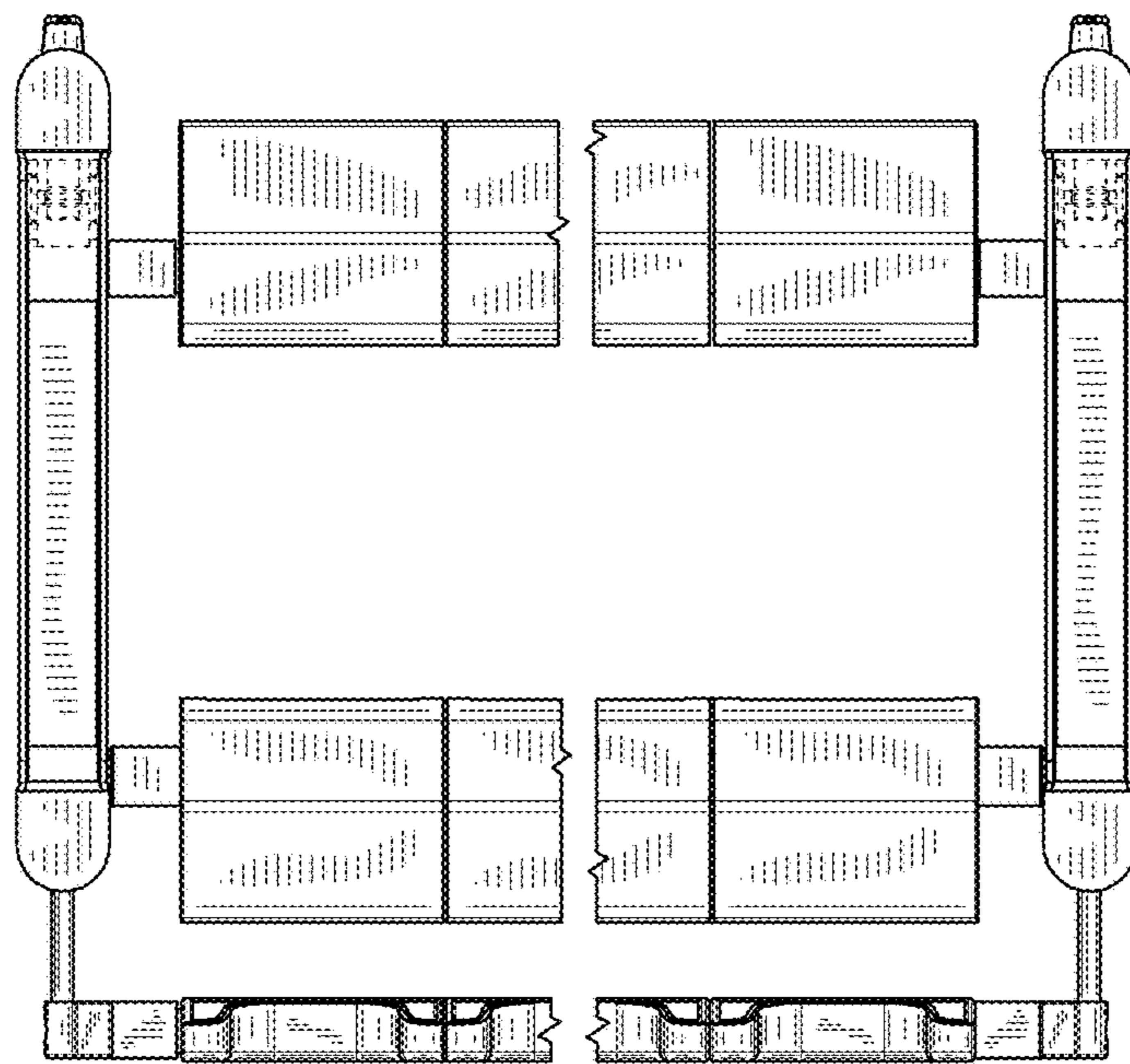

FIG. 14