



US00D869706S

(12) **United States Design Patent**
Rådbrink

(10) **Patent No.:** **US D869,706 S**

(45) **Date of Patent:** **** Dec. 10, 2019**

(54) **REAR LIGHT FOR A VEHICLE**

(71) Applicant: **Ningbo Geely Automobile Research & Development Co., Ltd., Ningbo (CN)**

(72) Inventor: **Jon Rådbrink, Göteborg (SE)**

(73) Assignee: **Ningbo Geely Automobile Research & Development Co., Ltd, Ningbo (CN)**

(**) Term: **15 Years**

(21) Appl. No.: **29/659,622**

(22) Filed: **Aug. 10, 2018**

(30) **Foreign Application Priority Data**

Feb. 13, 2018 (EM) 004707206

(51) **LOC (12) Cl.** **26-06**

(52) **U.S. Cl.**
USPC **D26/28**

(58) **Field of Classification Search**
USPC D26/28-36, 139
CPC F21S 48/00; F21S 48/10; F21S 48/115;
F21S 48/225; F21S 48/1233; F21S
48/1266; F21S 48/1388; F21S 48/2268;
F21V 5/00; B60Q 9/13; B60Q 9/135;
B60Q 9/1375

See application file for complete search history.

(56) **References Cited**

U.S. PATENT DOCUMENTS

D655,429 S *	3/2012	Fushimi	D26/28
D657,482 S *	4/2012	Kong	D26/28
D690,850 S *	10/2013	Hanaoka	D26/28
D692,599 S *	10/2013	Kim	D26/28
D701,631 S *	3/2014	Goto	D26/28
D716,478 S *	10/2014	Loeb	D26/28
D728,137 S *	4/2015	Ha	D26/28

* cited by examiner

Primary Examiner — Marcus A Jackson

(74) *Attorney, Agent, or Firm* — Tucker Ellis LLP

(57) **CLAIM**

The ornamental design for a rear light for a vehicle, as shown and described.

DESCRIPTION

FIG. 1 is a front-right perspective view of a rear light for a vehicle showing my new design;
FIG. 2 is a front view thereof;
FIG. 3 is a rear view thereof;
FIG. 4 is a right side view thereof;
FIG. 5 is a left side view thereof;
FIG. 6 is a top view thereof; and,
FIG. 7 is a bottom view thereof.

1 Claim, 5 Drawing Sheets

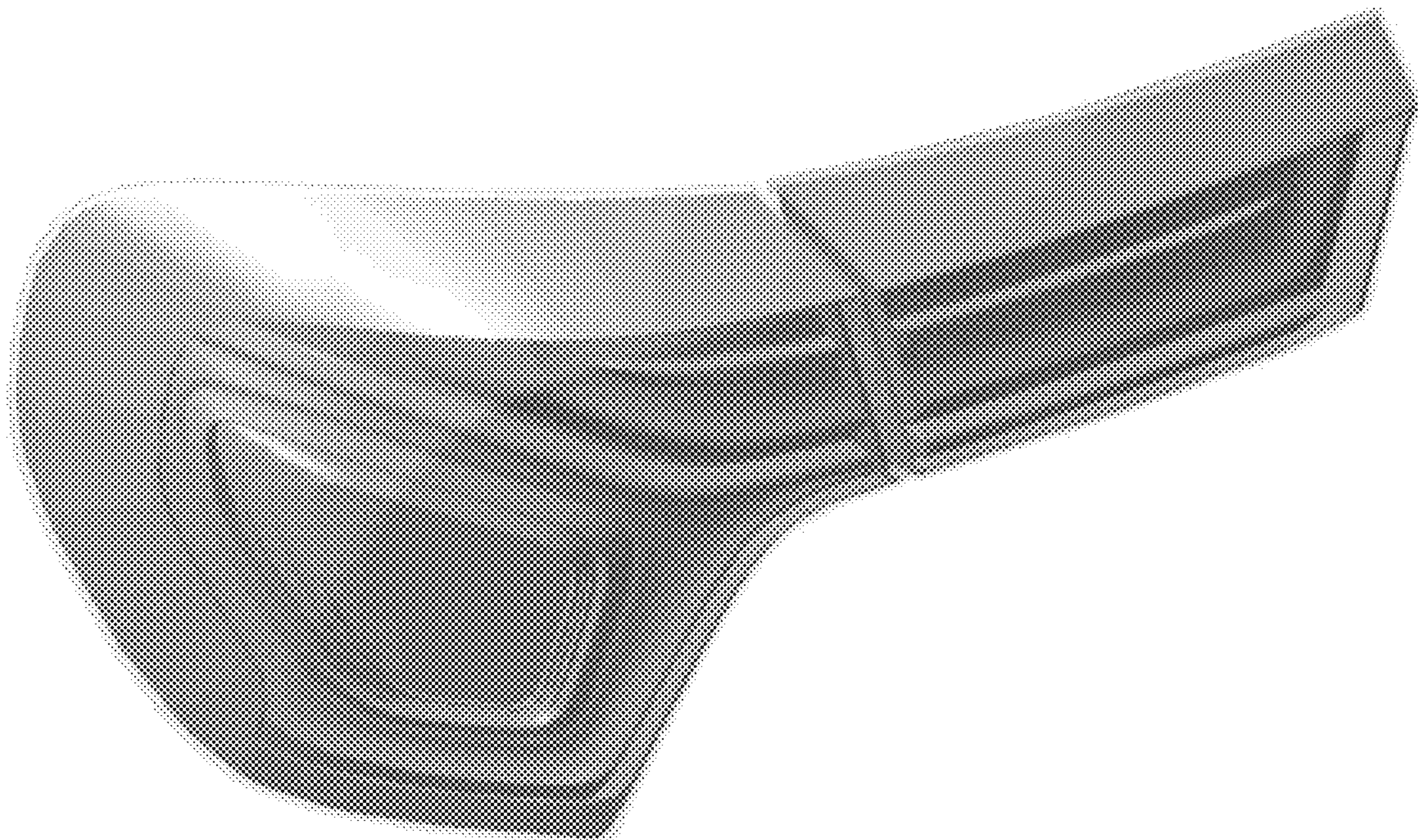

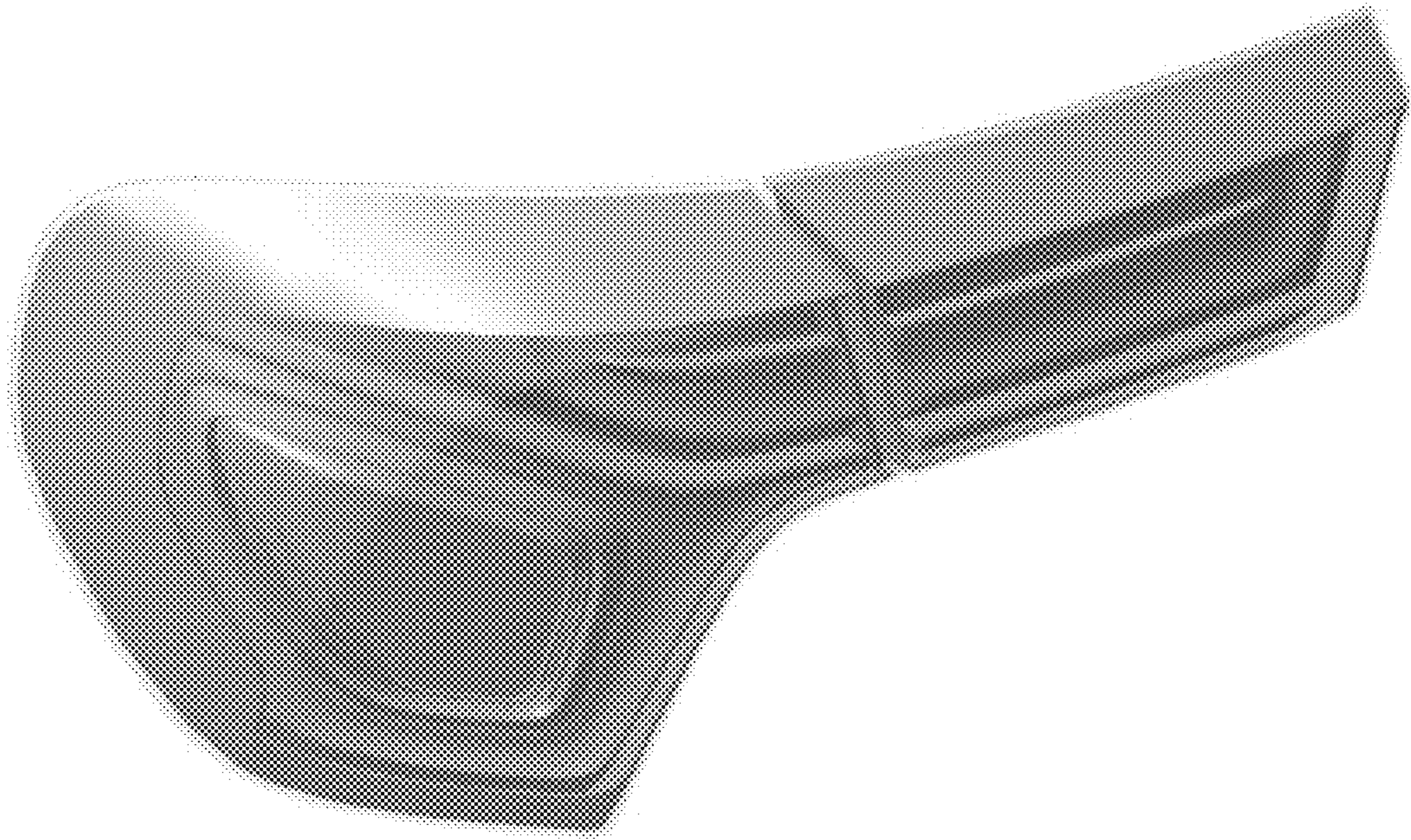

FIG. 1

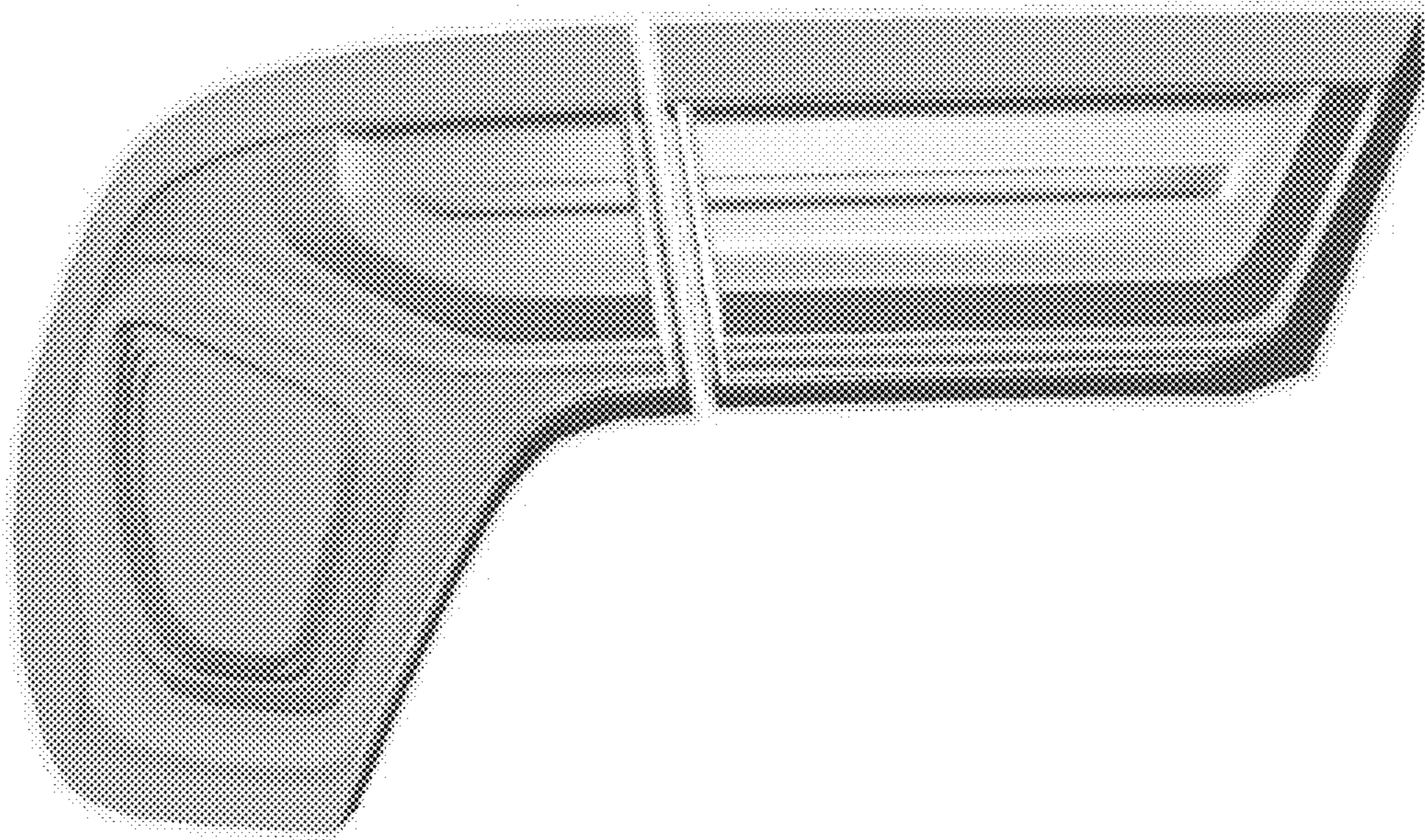

FIG. 2

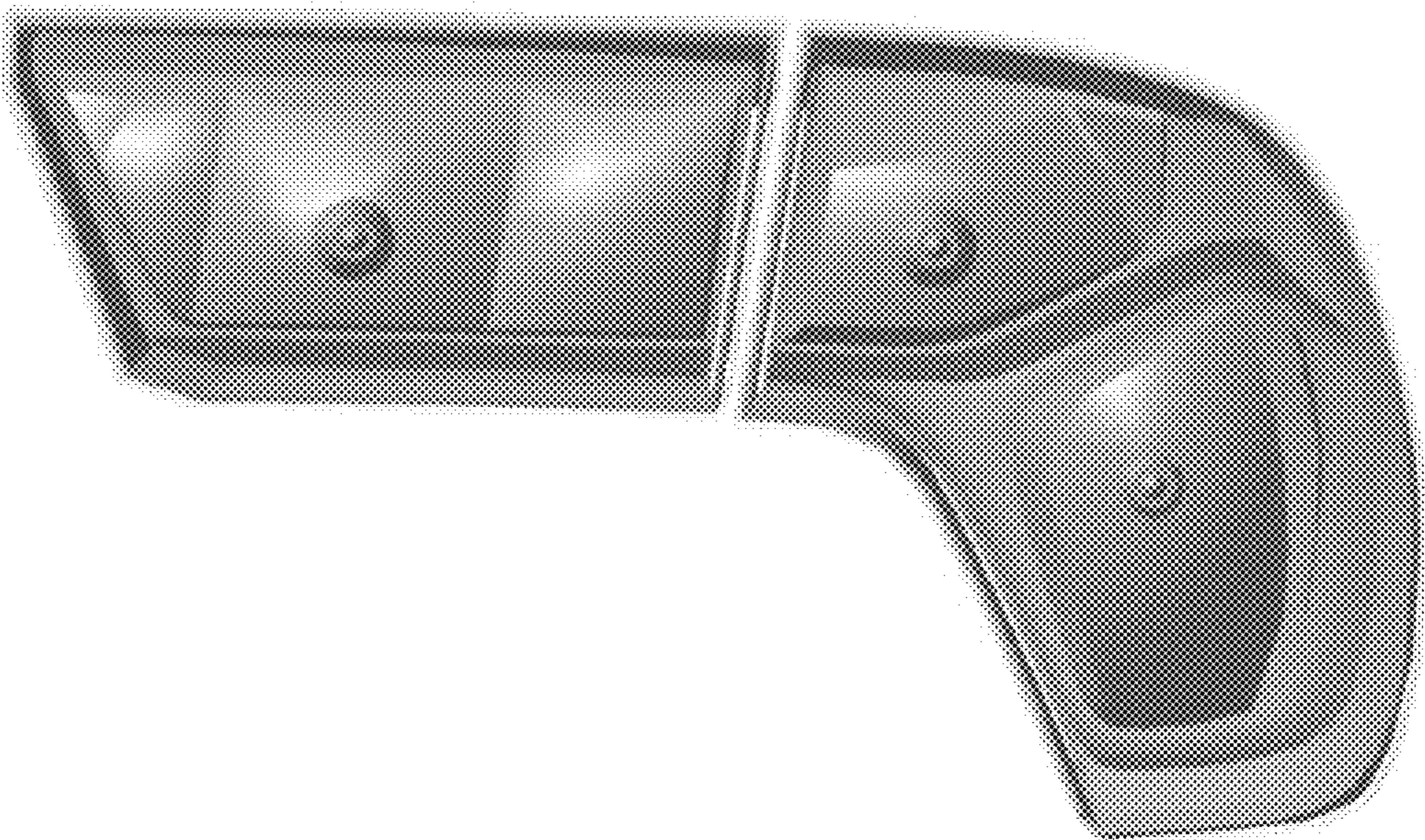

FIG. 3

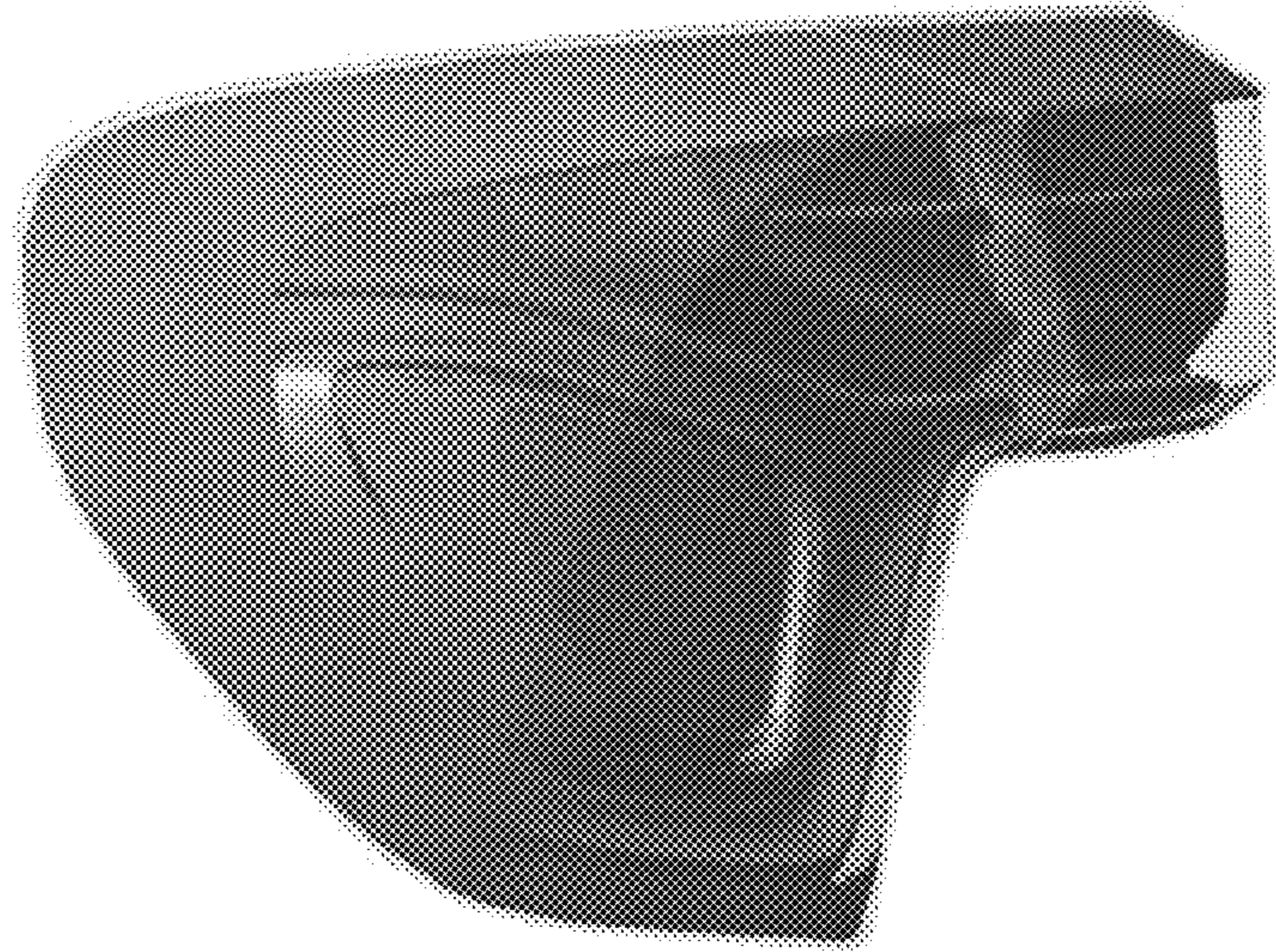

FIG. 4

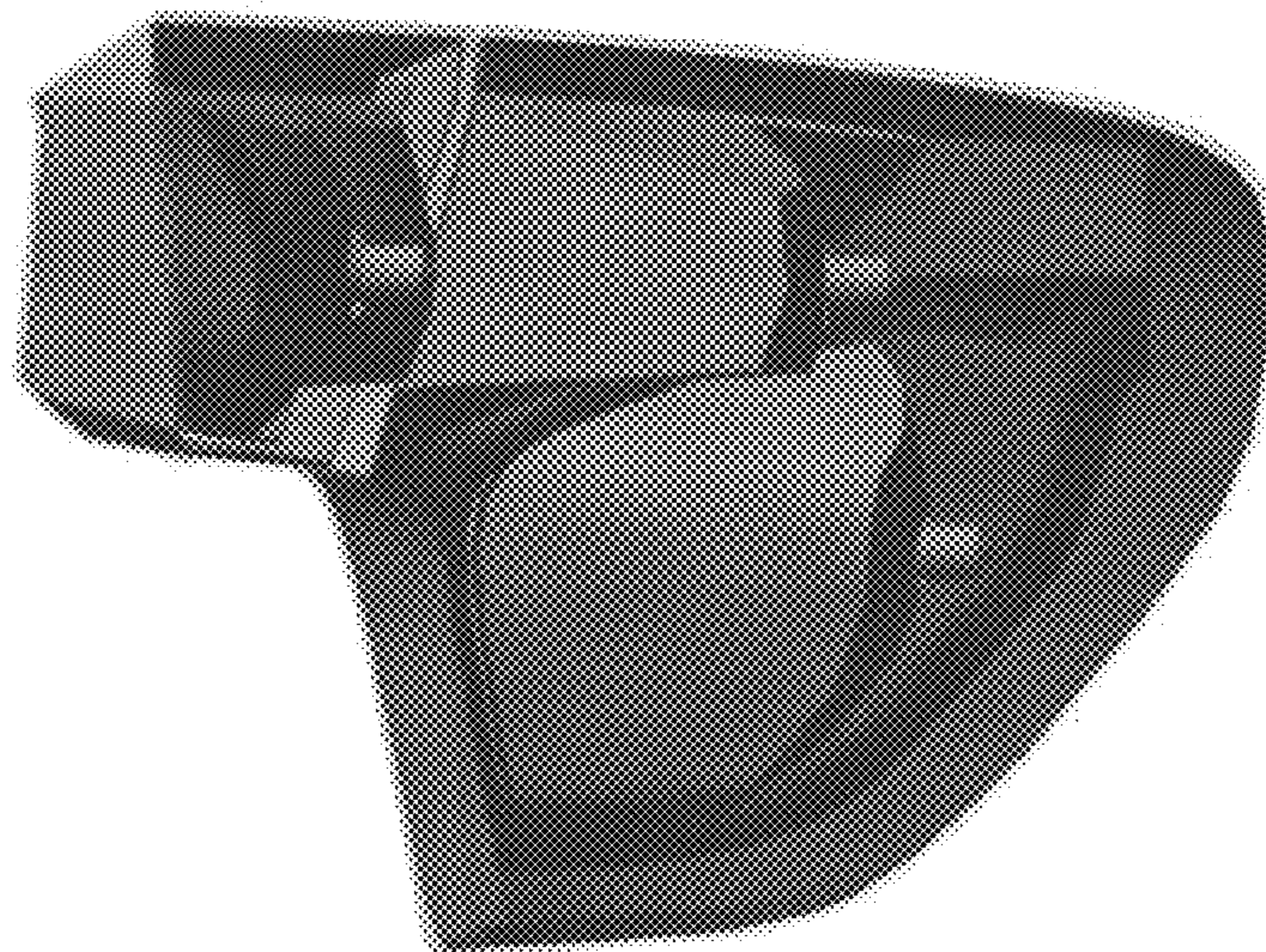

FIG. 5

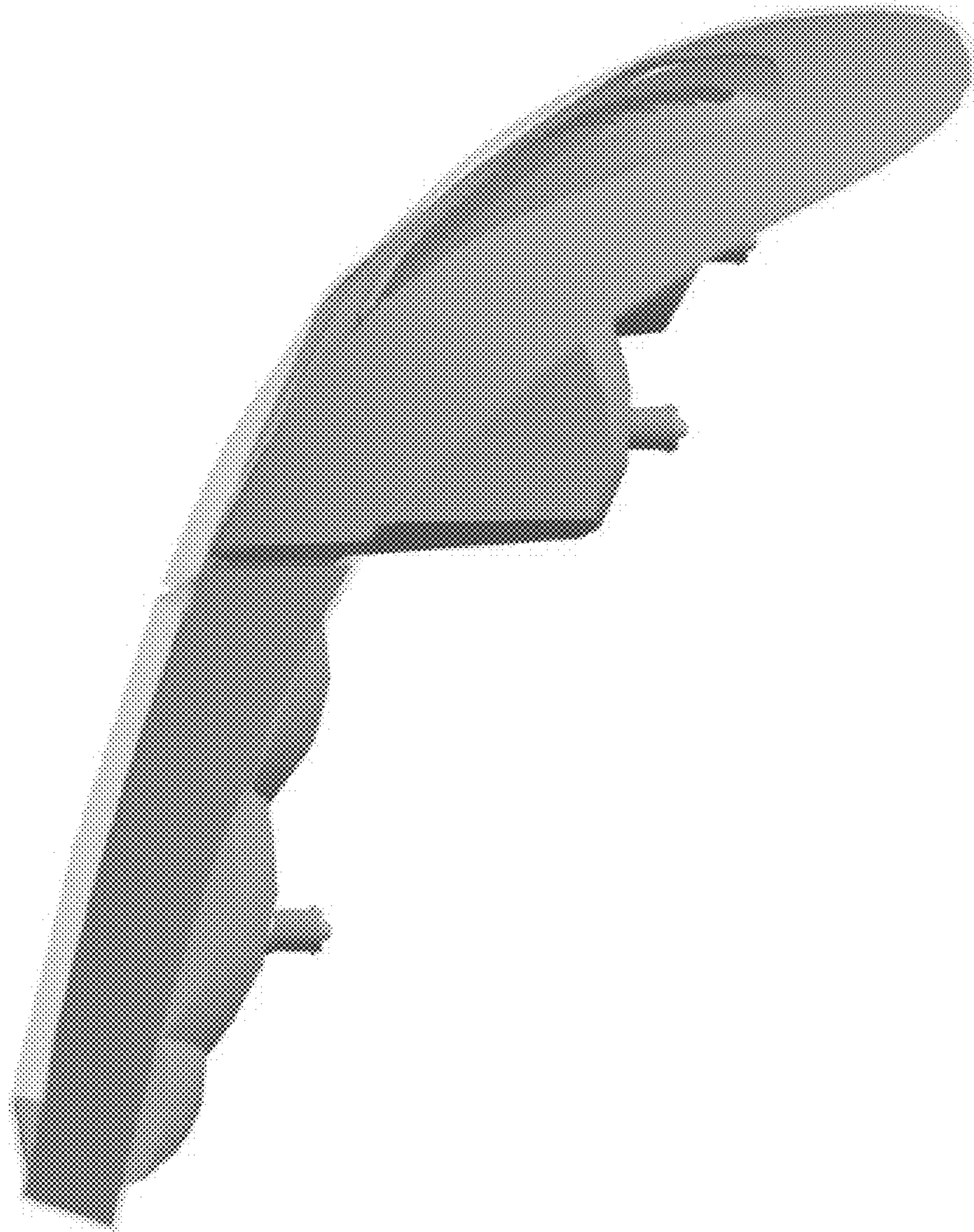

FIG. 6

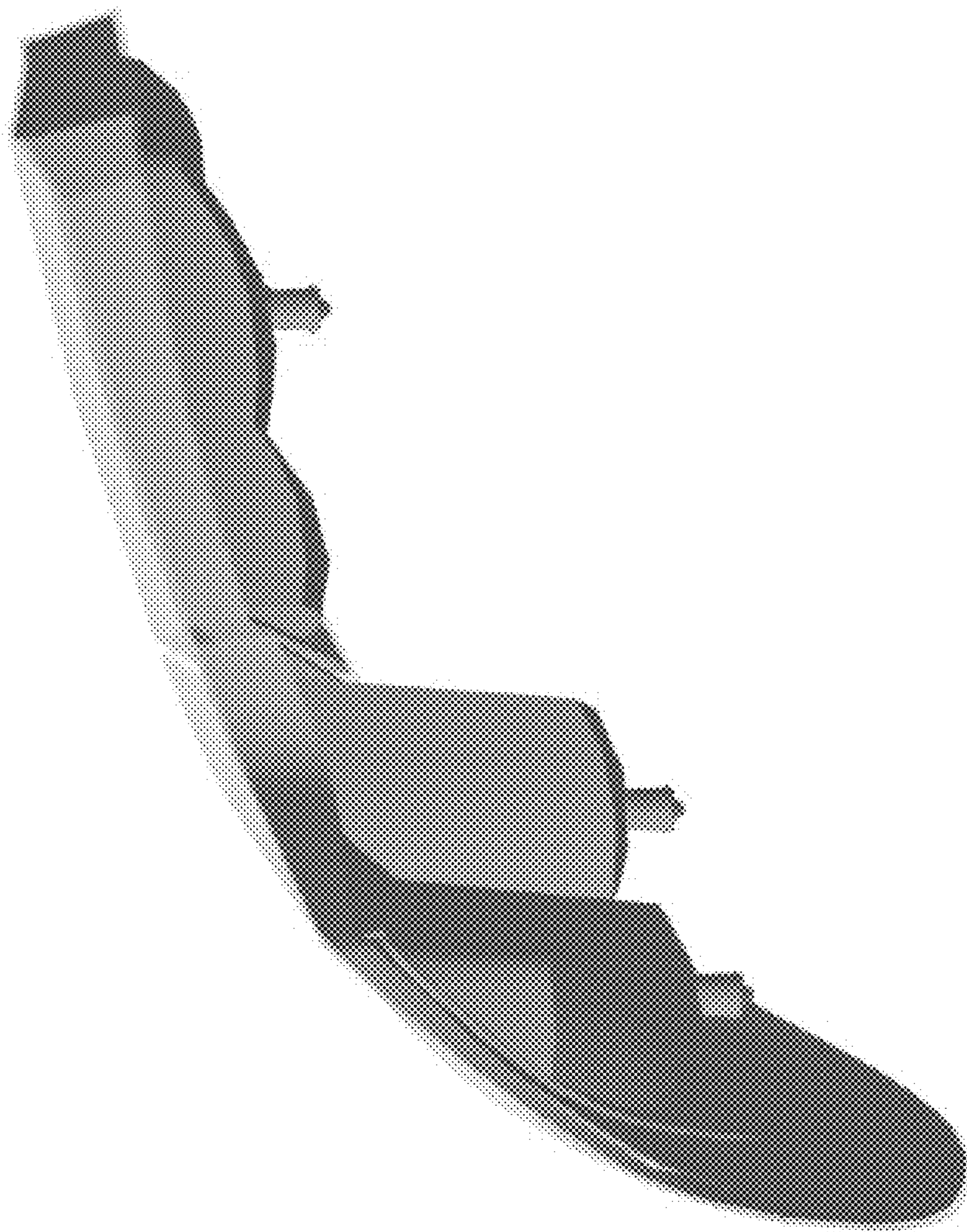

FIG. 7