

US00D869545S

(12) **United States Design Patent** (10) **Patent No.:** **US D869,545 S**  
**Lee** (45) **Date of Patent:** **\*\* Dec. 10, 2019**

(54) **VEHICLE VIDEO RECORDER CRADLE**

(71) Applicant: **THINKWARE CORPORATION**,  
Seongnam-si, Gyeonggi-Do (KR)

(72) Inventor: **Yong Lee**, Seoul (KR)

(73) Assignee: **THINKWARE CORPORATION**,  
Seongnam-si (KR)

(\*\*) Term: **15 Years**

(21) Appl. No.: **29/644,735**

(22) Filed: **Apr. 20, 2018**

(30) **Foreign Application Priority Data**

Jan. 4, 2018 (KR) ..... 30-2018-0000529

(51) **LOC (12) Cl.** ..... **16-05**

(52) **U.S. Cl.**  
USPC ..... **D16/242**

(58) **Field of Classification Search**  
USPC ..... D16/219, 237-250; D14/224, 229, 238,  
D14/251, 253; D8/354, 355, 363, 373,  
D8/382-383, 394-396  
CPC ..... F16M 11/06-10; F16M 11/14; G02B  
7/00-002; G03B 17/56; G03B  
17/561-568; H04N 5/2253-2254; A45F  
2200/0508-0533; A45F 5/00; A45F 5/10  
See application file for complete search history.

(56) **References Cited**

U.S. PATENT DOCUMENTS

D318,607 S \* 7/1991 Reid ..... D8/363  
5,735,441 A \* 4/1998 Fujimoto ..... B62J 11/00  
224/420

D665,006 S \* 8/2012 Green ..... D16/242  
D764,567 S \* 8/2016 Bennett ..... D16/242  
D775,111 S \* 12/2016 Koch ..... D14/238  
D798,938 S \* 10/2017 Zheng ..... D16/237  
D798,939 S \* 10/2017 Costa ..... D16/242  
D798,940 S \* 10/2017 Costa ..... D16/242  
9,861,182 B2 \* 1/2018 Oberpriller ..... A45F 5/00  
D821,365 S \* 6/2018 Gheysens ..... D14/224  
D822,091 S \* 7/2018 Zheng ..... D16/242  
D833,265 S \* 11/2018 Meola ..... D8/396

\* cited by examiner

Primary Examiner — Vy N Koenig

(74) Attorney, Agent, or Firm — Leber IP Law; David C. Robertson

(57) **CLAIM**

The ornamental design for a vehicle video recorder cradle, as shown and described.

**DESCRIPTION**

FIG. 1 is a perspective view of a vehicle video recorder cradle showing my new design;  
FIG. 2 is a front elevational view thereof;  
FIG. 3 is a rear elevational view thereof;  
FIG. 4 is a left side elevational view thereof;  
FIG. 5 is a right side elevational view thereof;  
FIG. 6 is a top view thereof; and,  
FIG. 7 is a bottom view thereof.

The broken lines shown in the drawings depict portions of the vehicle video recorder cradle that form no part of the claimed design.

**1 Claim, 7 Drawing Sheets**

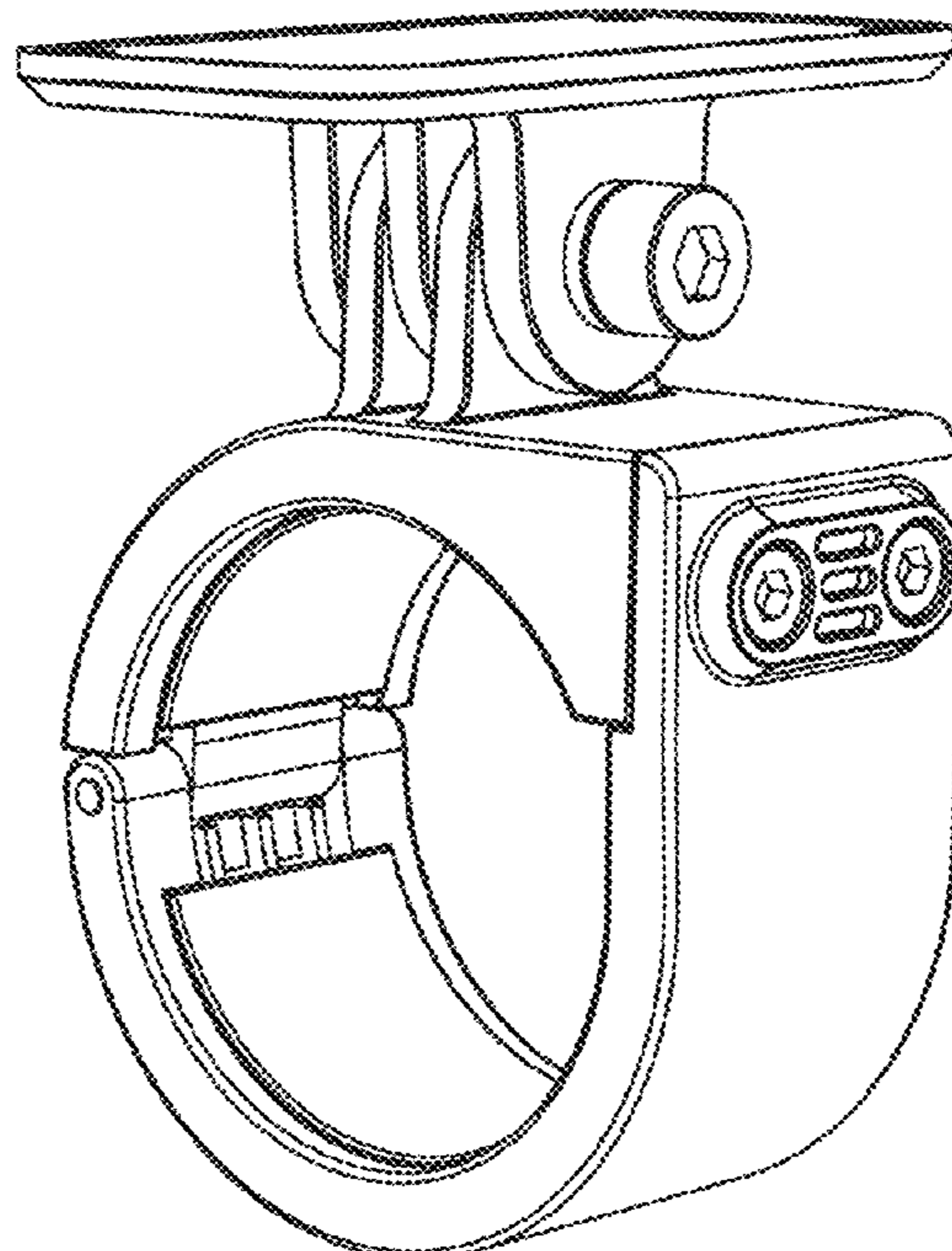

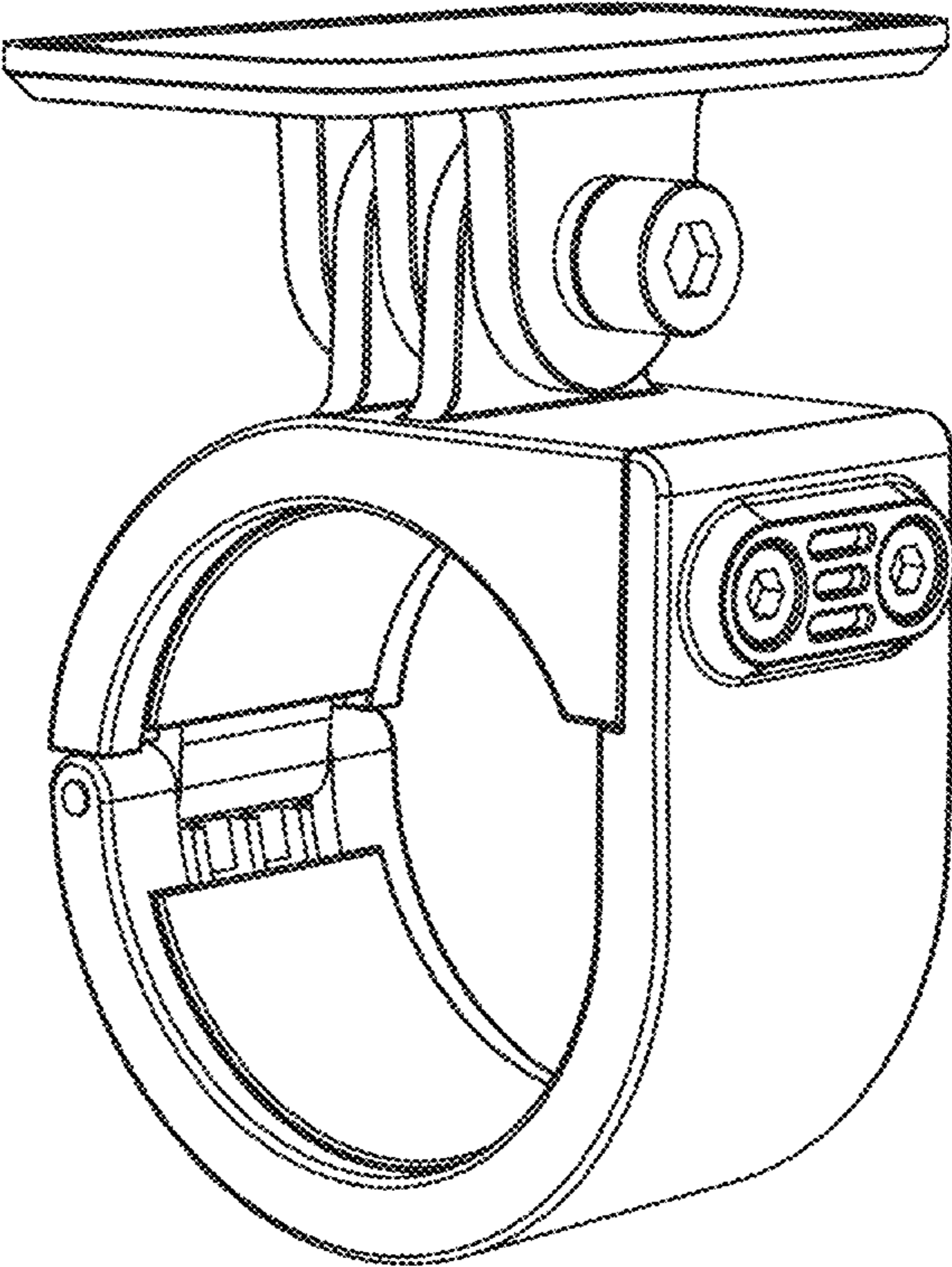

FIG 1

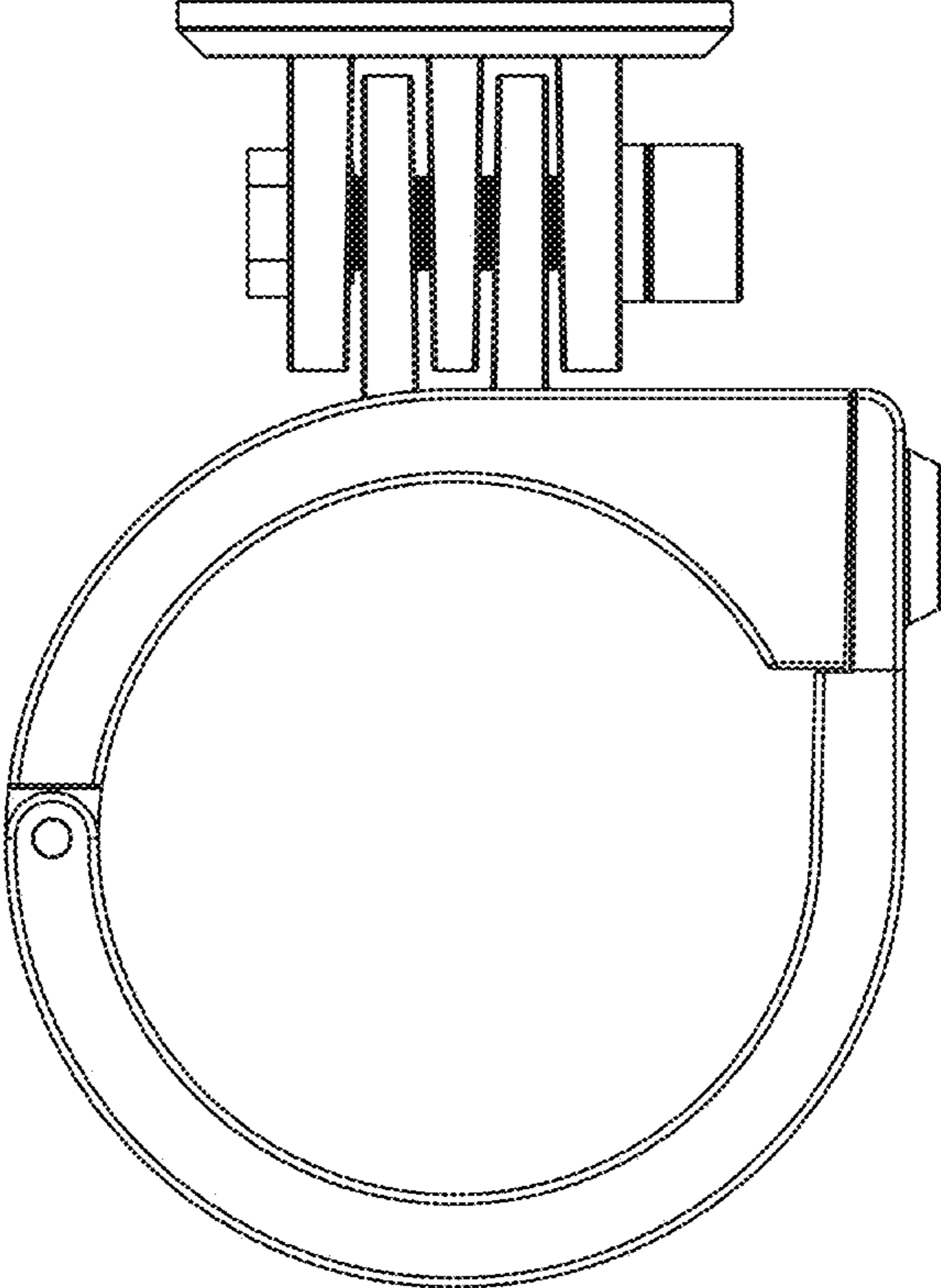

FIG 2

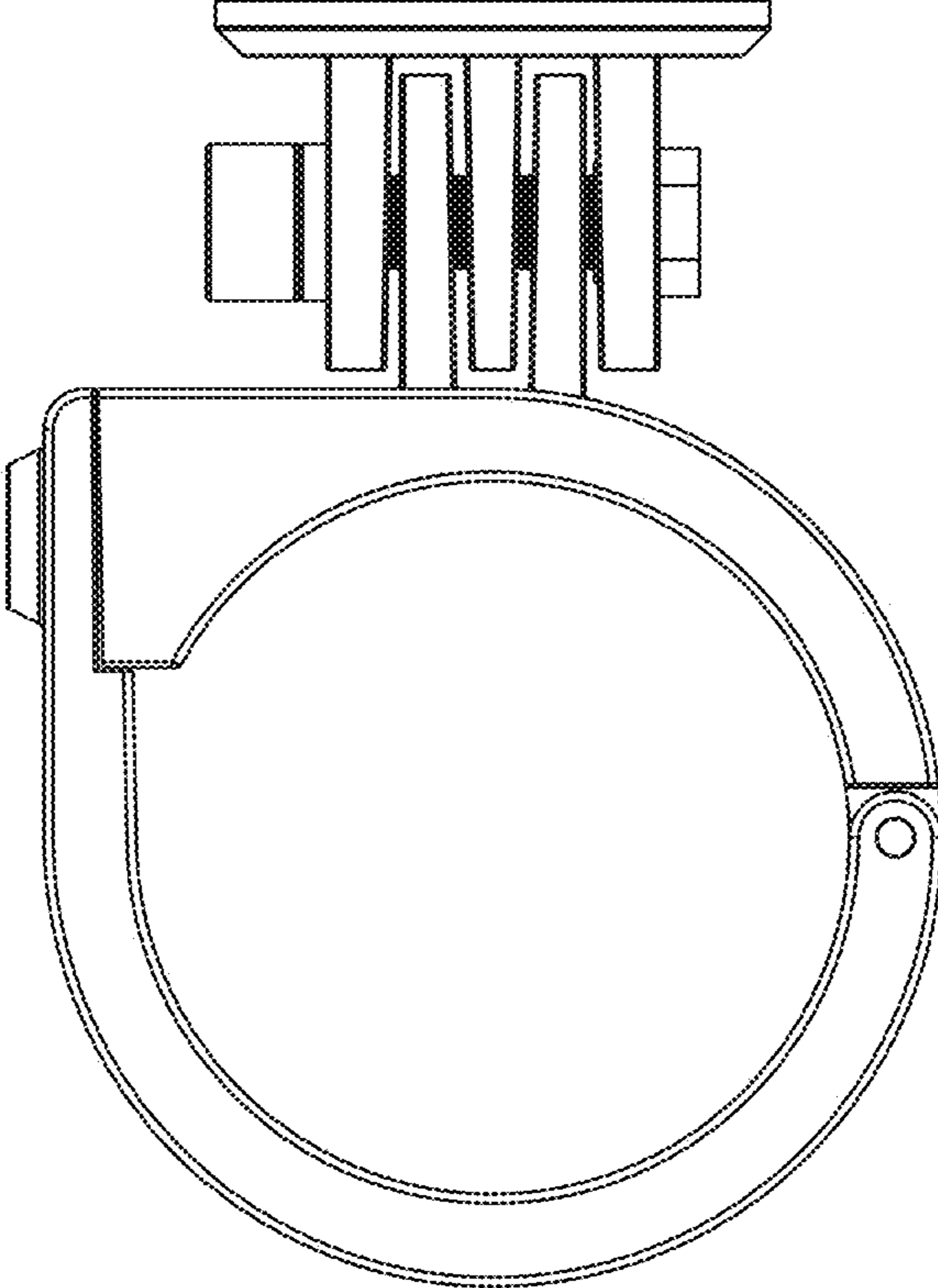

FIG 3

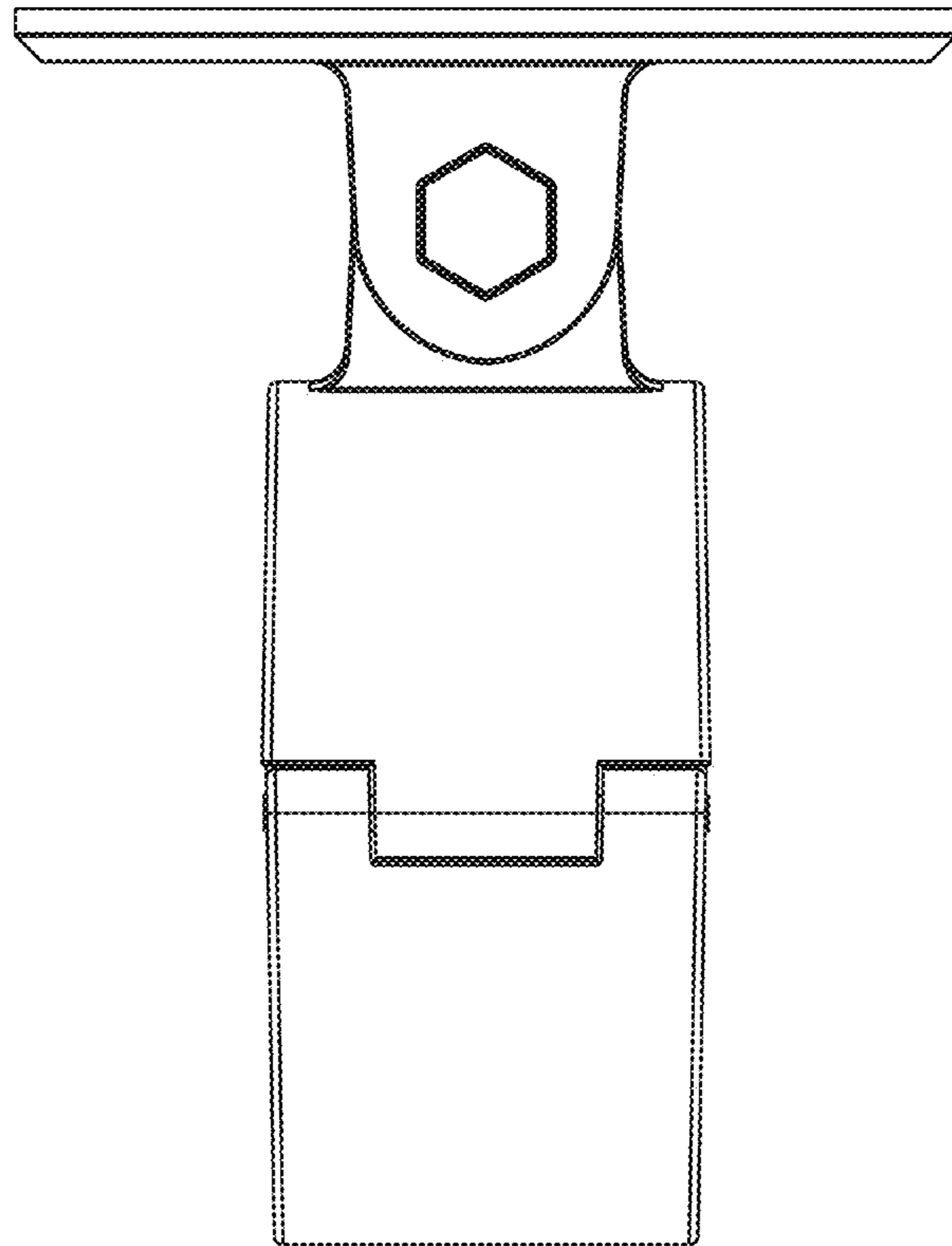

FIG 4

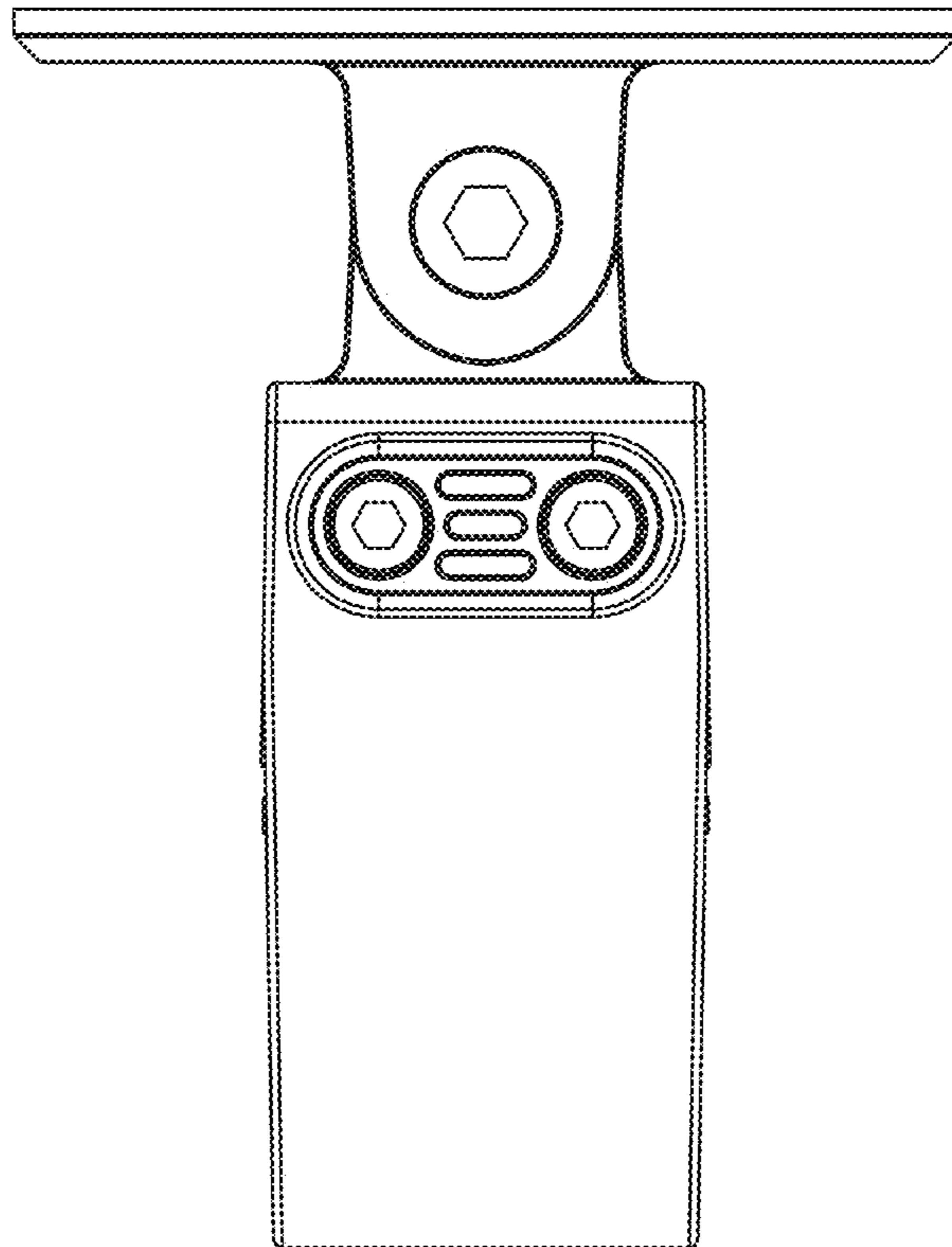

FIG 5

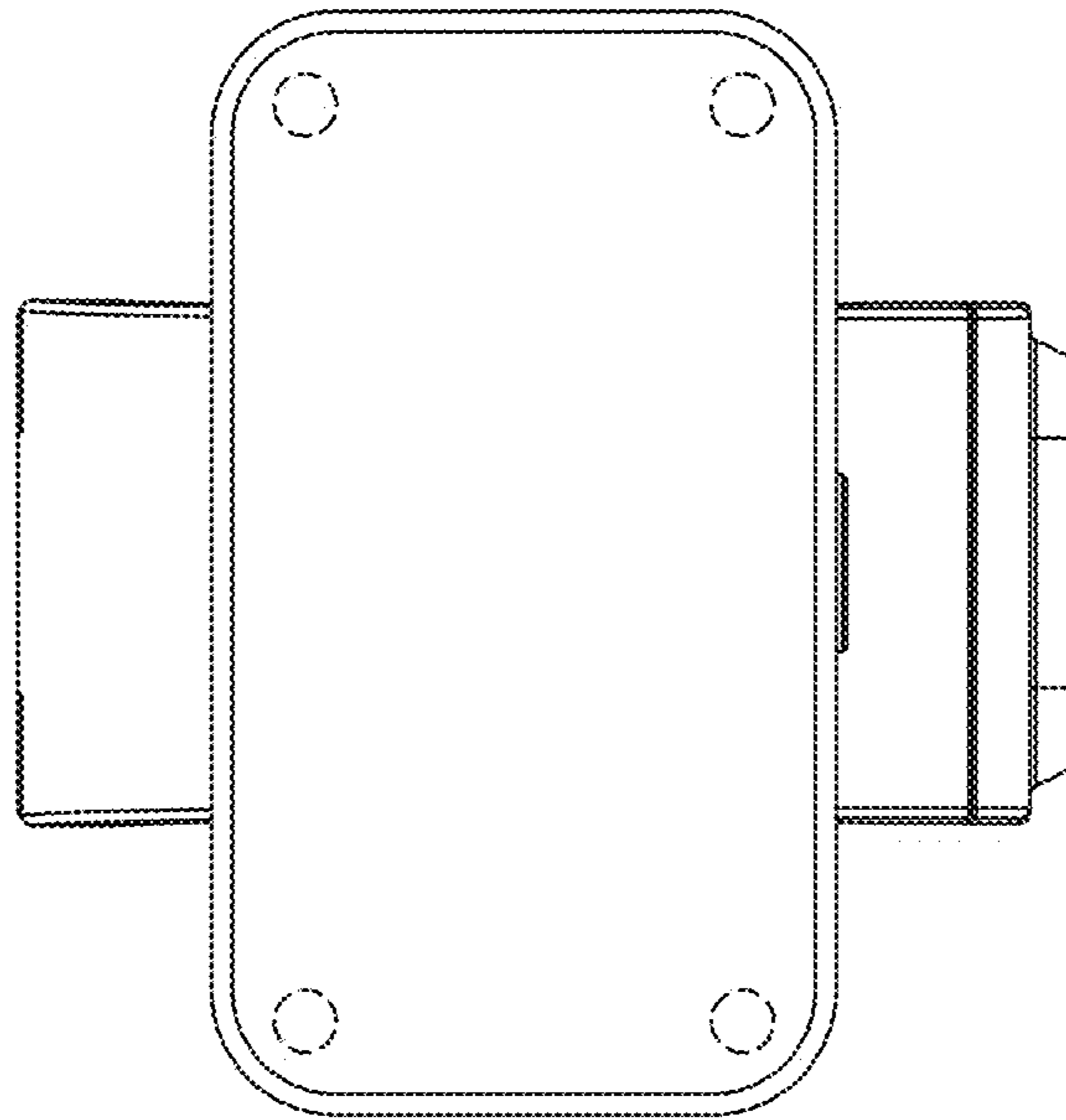

FIG 6

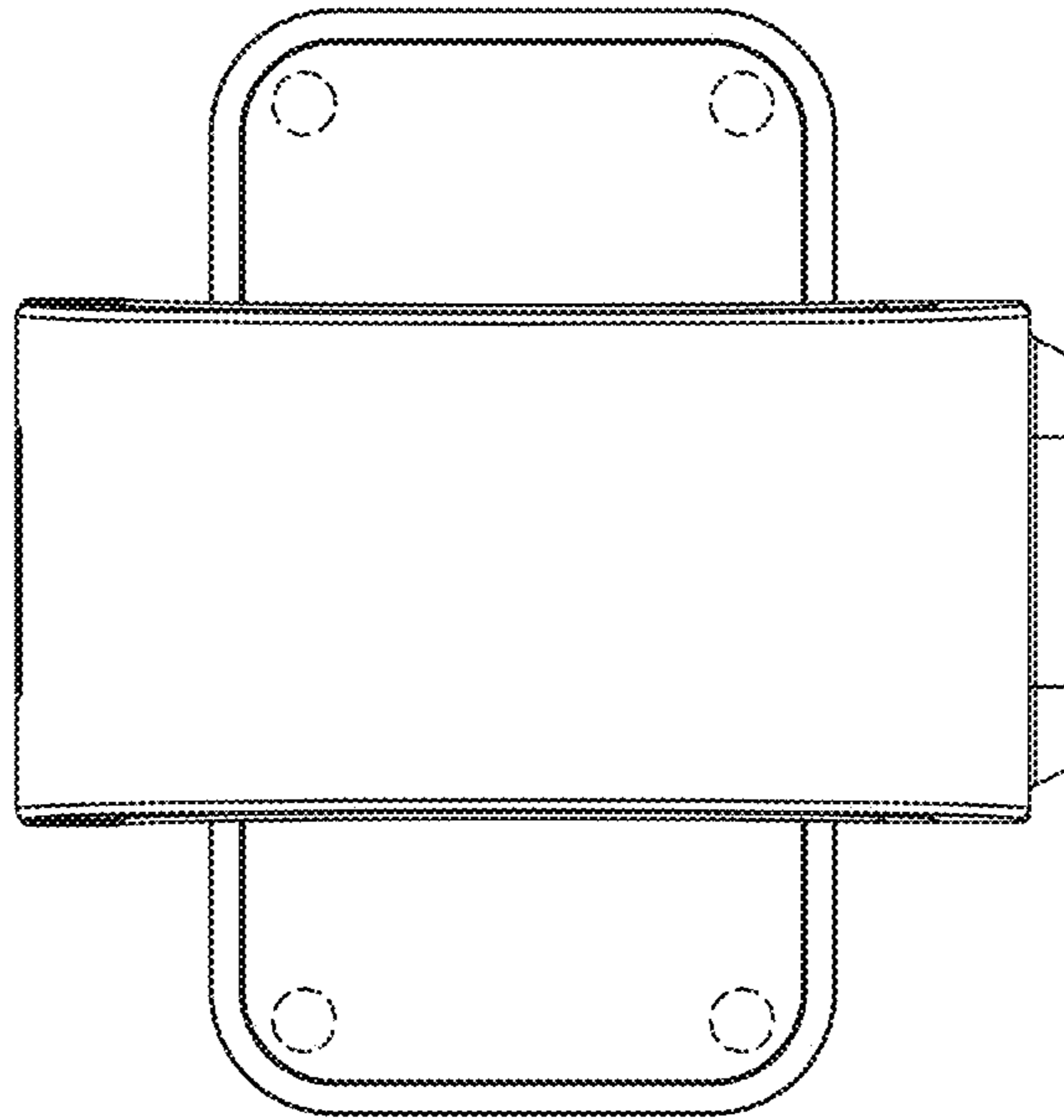

FIG 7