



US00D869506S

(12) **United States Design Patent** (10) **Patent No.:** **US D869,506 S**
Jiang et al. (45) **Date of Patent:** **** Dec. 10, 2019**

(54) **COOLANT VALVE**
(71) Applicant: **Hangzhou Sanhua Research Institute Co., Ltd.**, Hangzhou, Zhejiang (CN)
(72) Inventors: **Huayuan Jiang**, Zhejiang (CN); **Zhi Wu**, Zhejiang (CN); **Yaoyao Zhang**, Zhejiang (CN); **Long Lin**, Zhejiang (CN)
(73) Assignee: **Hangzhou Sanhua Research Institute Co., Ltd.**, Hangzhou, Zhejiang (CN)

D691,638 S * 10/2013 Alexander D15/7
D699,762 S * 2/2014 Alexander D15/7
D768,208 S * 10/2016 Pademi D15/7

(**) Term: **15 Years**
(21) Appl. No.: **29/631,090**
(22) Filed: **Dec. 27, 2017**

OTHER PUBLICATIONS

U.S. Appl. No. 29/631,087, filed Dec. 27, 2017, Lin et al.
U.S. Appl. No. 29/631,095, filed Dec. 27, 2017, Shentu et al.
U.S. Appl. No. 29/631,101, filed Dec. 27, 2017, Zhang et al.

* cited by examiner

Primary Examiner — Khawaja Anwar
(74) *Attorney, Agent, or Firm* — Wolf, Greenfield & Sacks, P.C.

(30) **Foreign Application Priority Data**

Jun. 29, 2017 (CN) 2017 3 0280062
(51) **LOC (12) Cl.** **15-03**
(52) **U.S. Cl.**
USPC **D15/7**
(58) **Field of Classification Search**
USPC D15/7-9; D23/225, 231, 232
CPC F02M 37/04; F02M 37/14
See application file for complete search history.

DESCRIPTION

FIG. 1 is a front view of a coolant valve according to the present application;
FIG. 2 is a rear view of the coolant valve according to the present application;
FIG. 3 is a left view of the coolant valve according to the present application;
FIG. 4 is a right view of the coolant valve according to the present application;
FIG. 5 is a top view of the coolant valve according to the present application;
FIG. 6 is a bottom view of the coolant valve according to the present application; and,
FIG. 7 is a perspective view of the coolant valve according to the present application.
The broken lines depict parts of the coolant valve that form no part of the claimed design.

(56) **References Cited**

U.S. PATENT DOCUMENTS

D536,005 S * 1/2007 Reverberi D15/5
D582,434 S * 12/2008 Turgut D15/7
D582,435 S * 12/2008 Turgut D15/7
D591,311 S * 4/2009 Tojo D15/7
D633,406 S * 3/2011 Magri D15/7

1 Claim, 7 Drawing Sheets

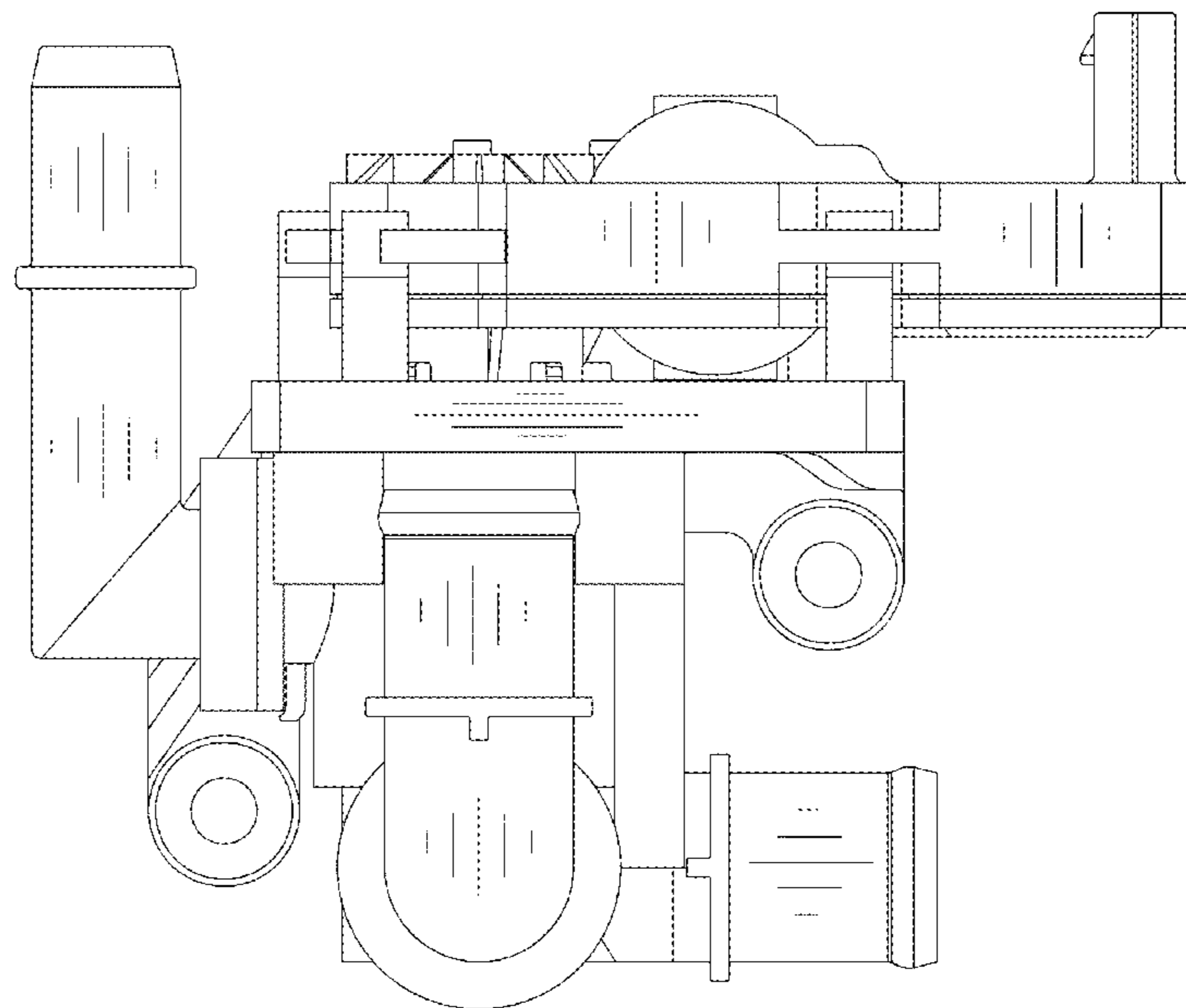

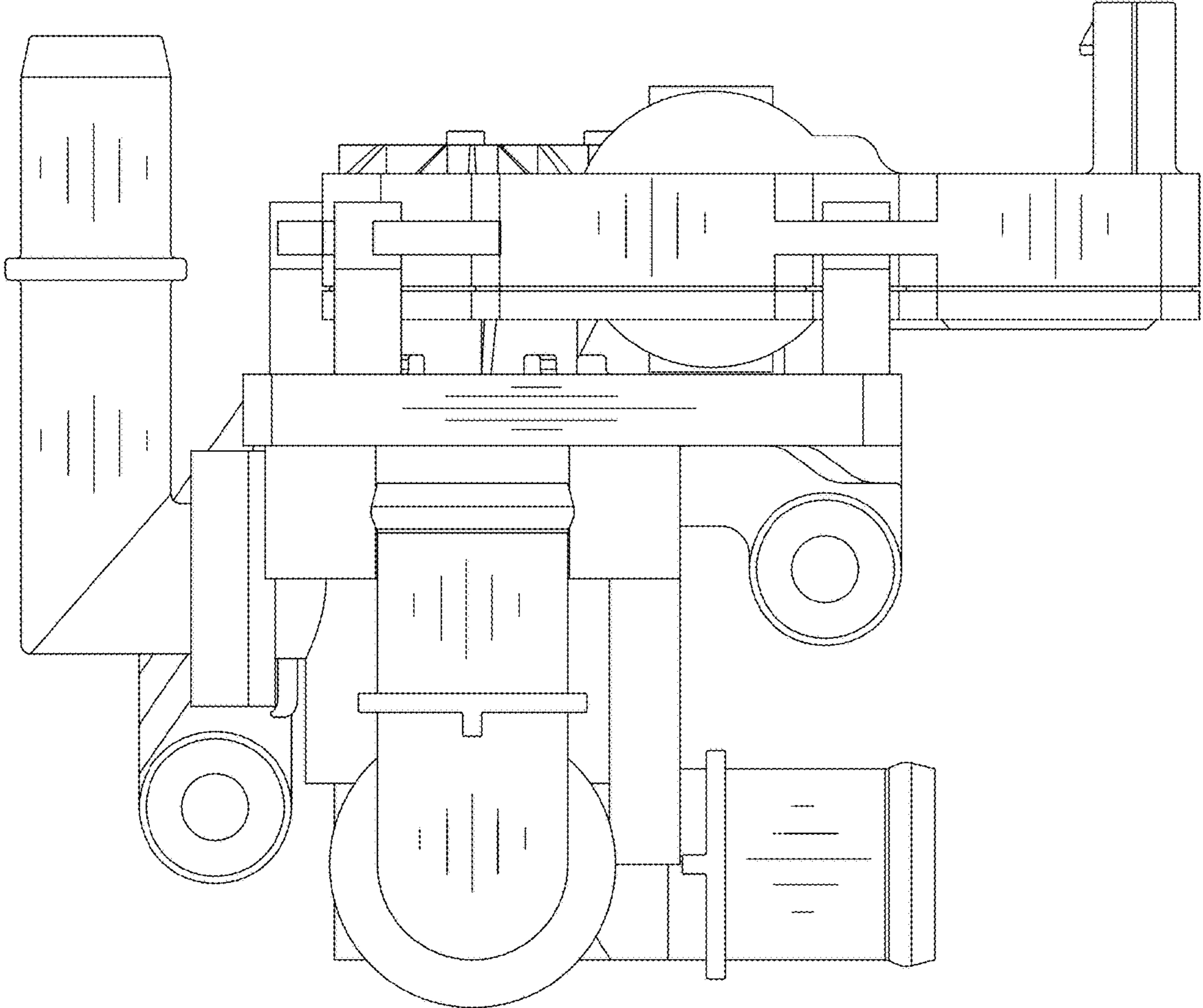

Fig. 1

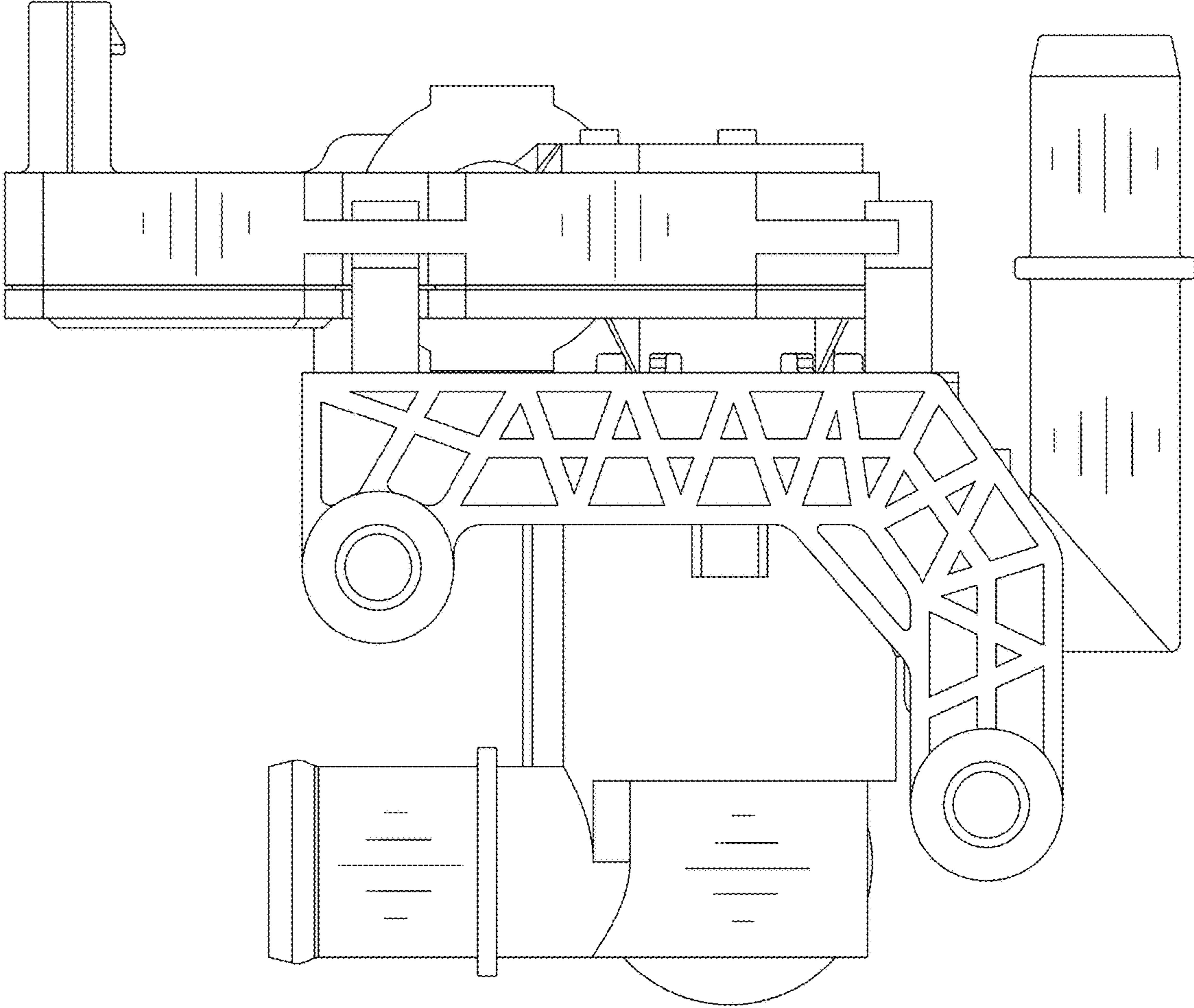

Fig. 2

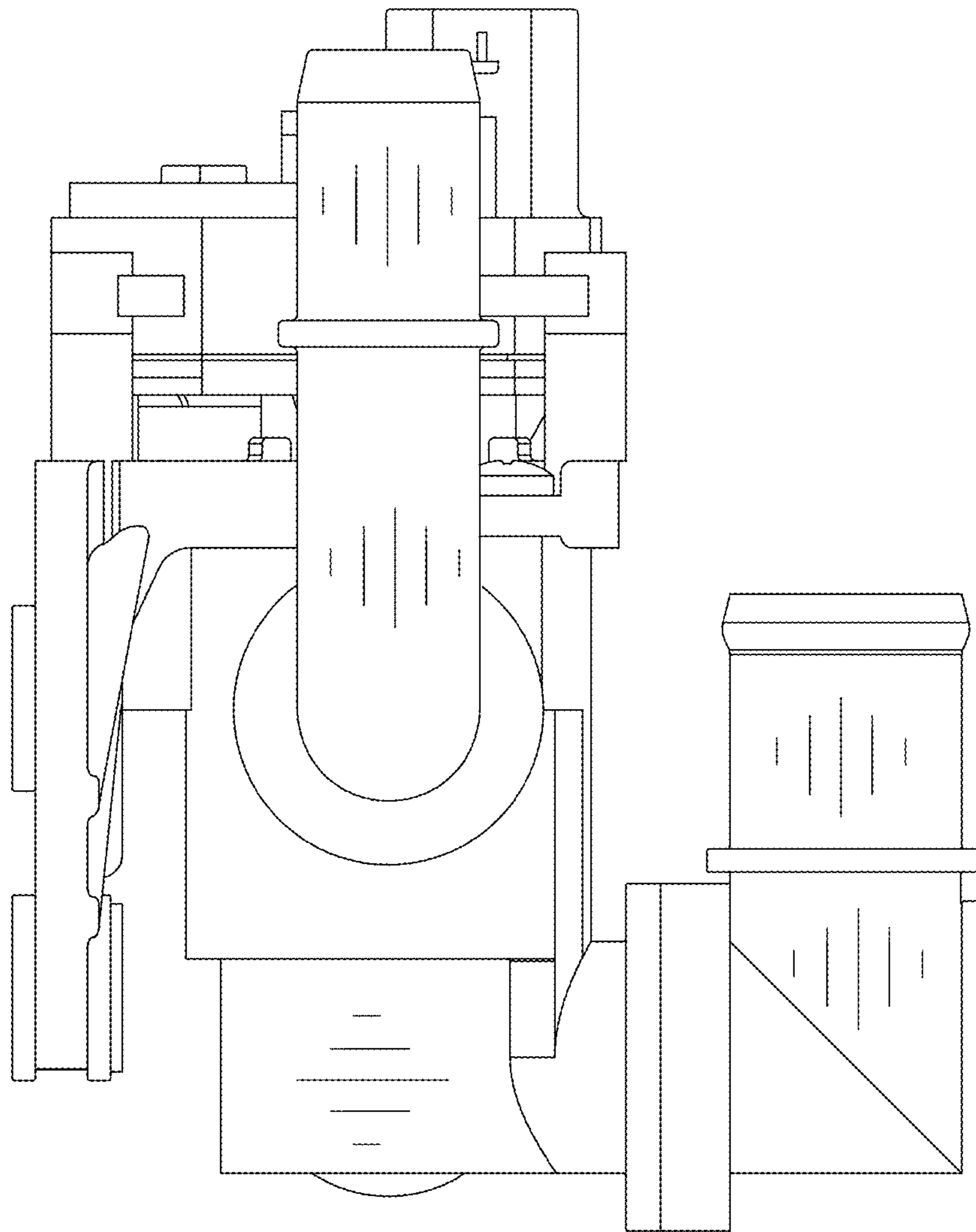

Fig. 3

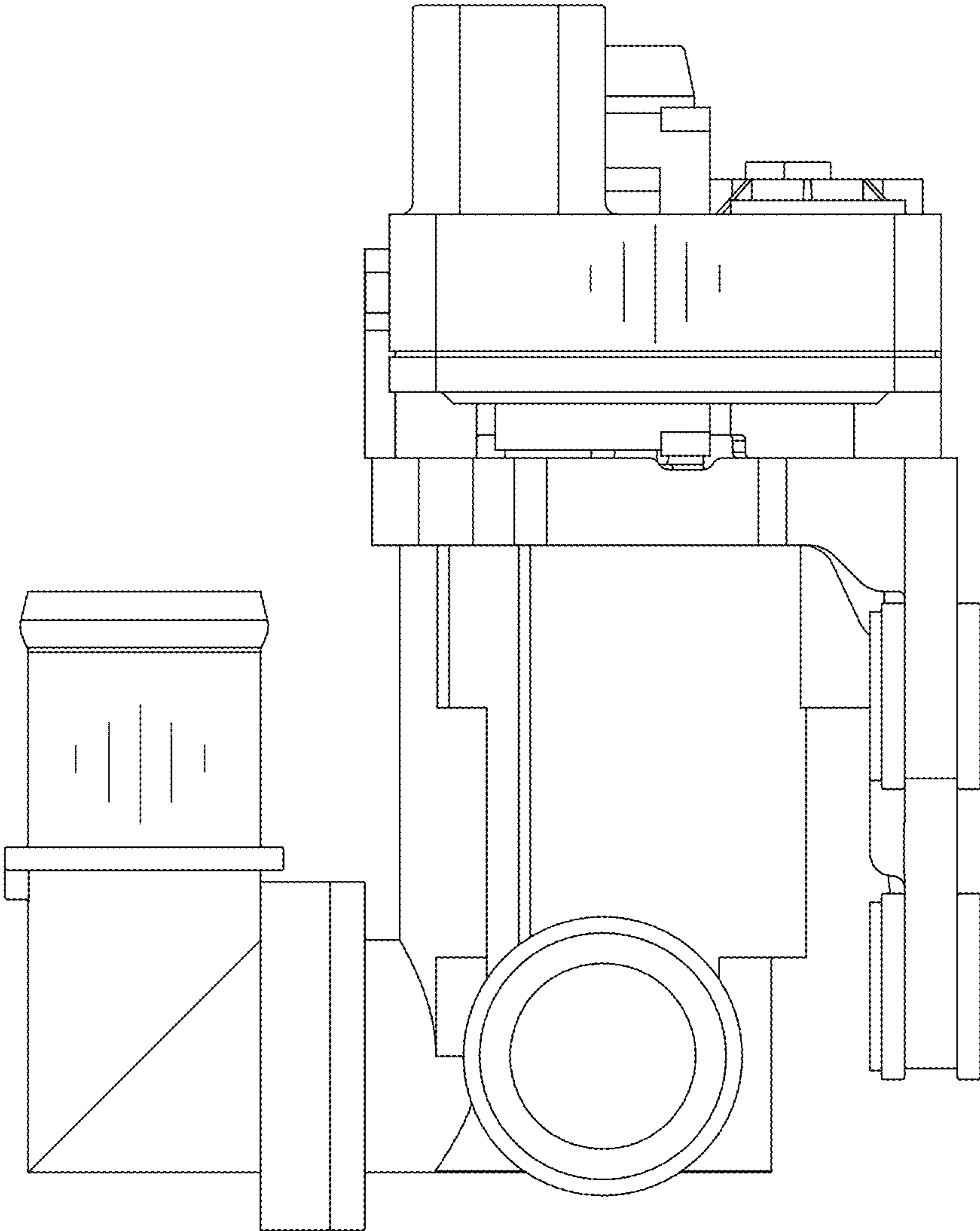

Fig. 4

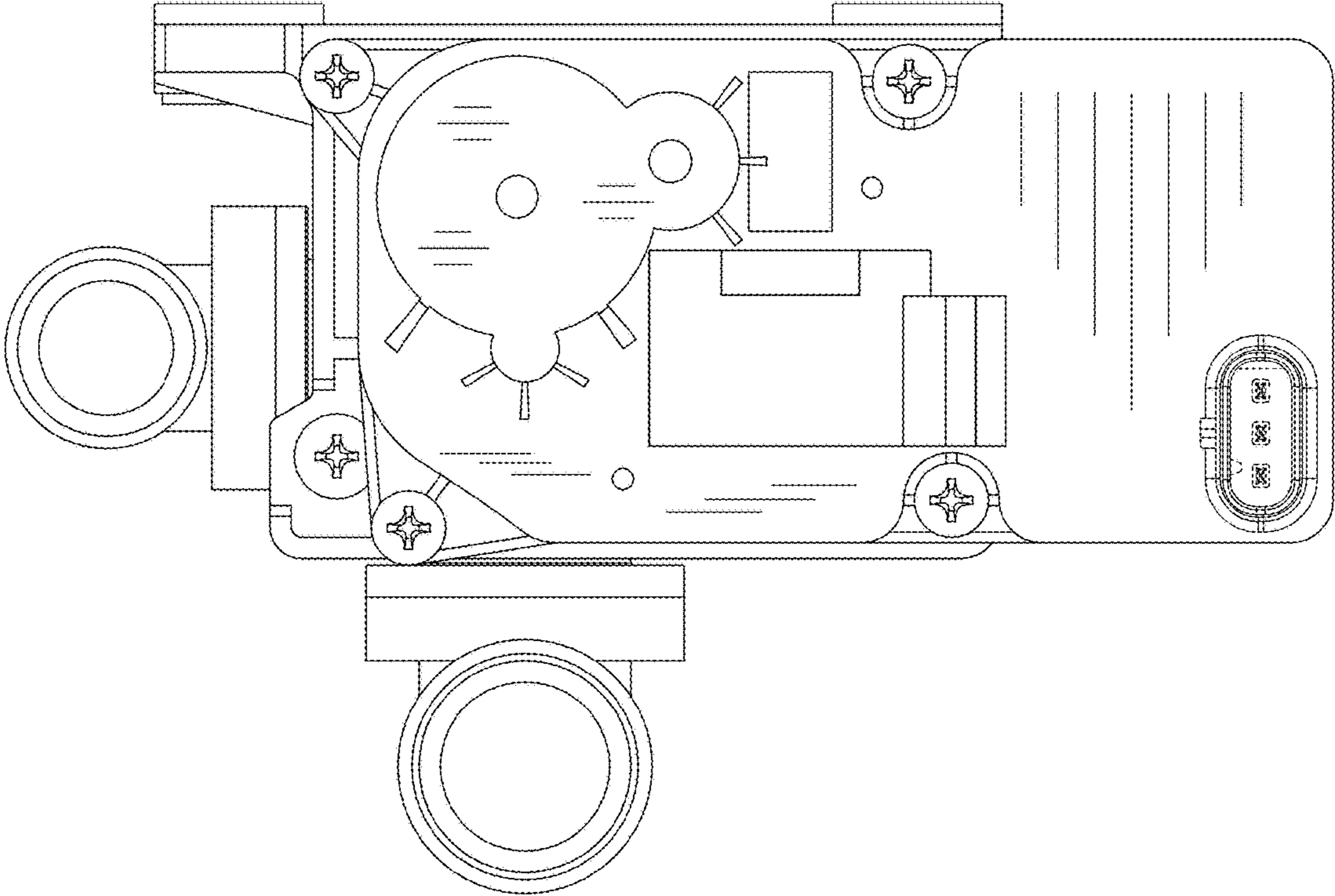

Fig. 5

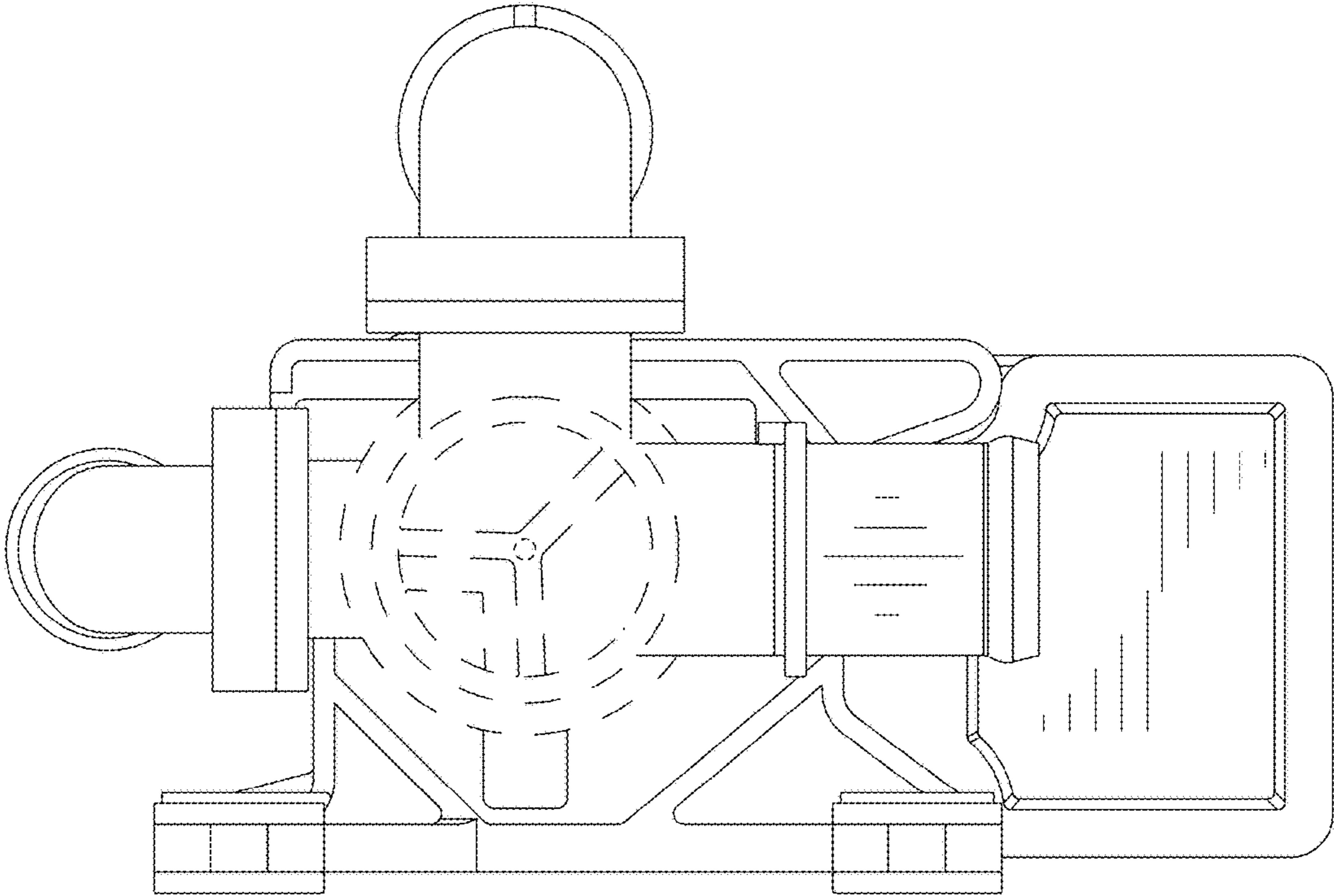

Fig. 6

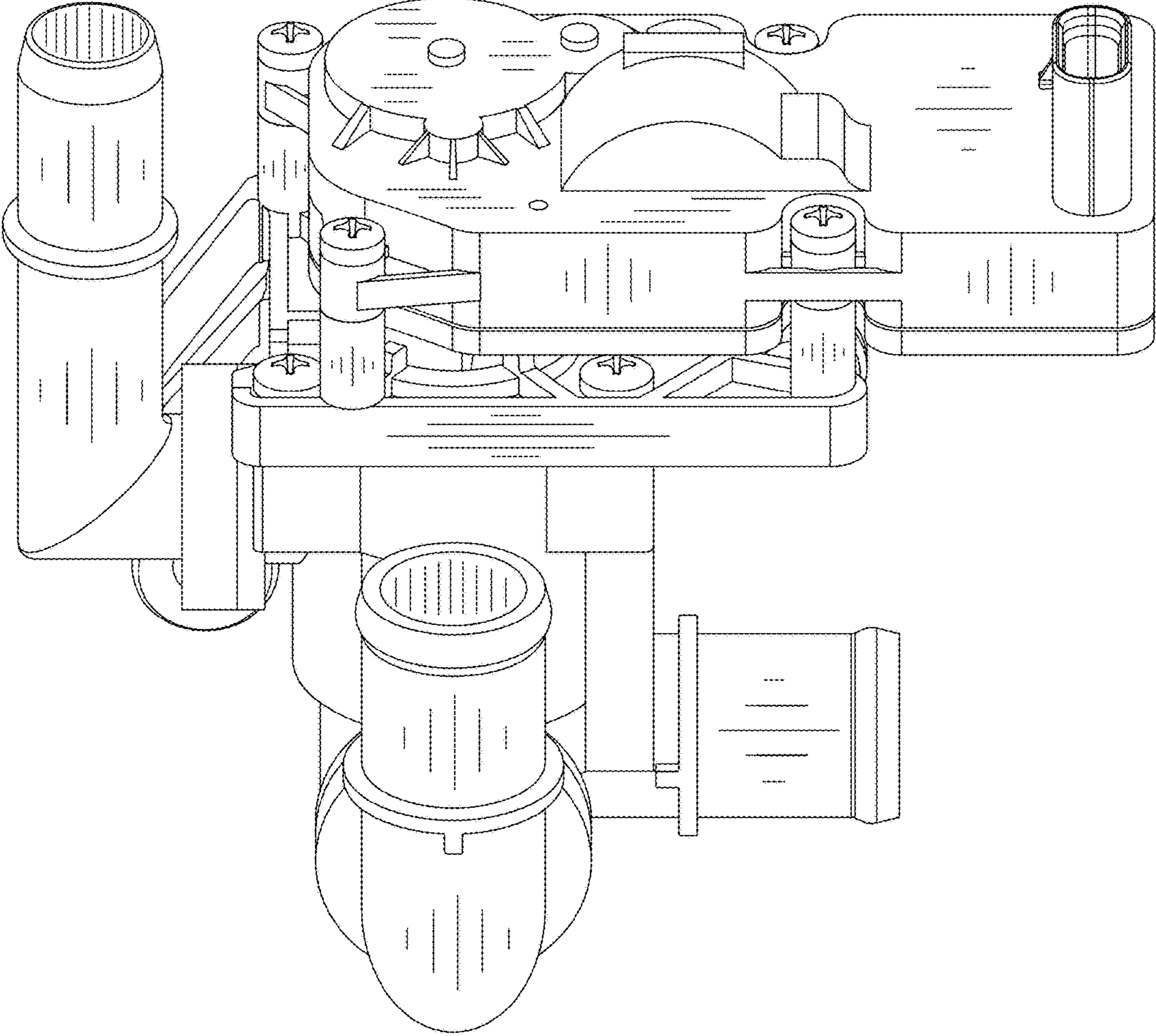

Fig. 7