



US00D869428S

(12) **United States Design Patent** (10) **Patent No.:** **US D869,428 S**
Vaclavik et al. (45) **Date of Patent:** **** Dec. 10, 2019**

(54) **LOUDSPEAKER**
(71) Applicant: **Harman International Industries, Incorporated**, Northridge, CA (US)
(72) Inventors: **Ondrej Vaclavik**, Shenzhen (CN); **Alexander Demin**, Shenzhen (CN)
(73) Assignee: **Harman International Industries, Incorporated**, Northridge, CA (US)

D549,960 S * 9/2007 Gonzalez D3/246
D550,633 S * 9/2007 Gupta D13/168
D560,209 S 1/2008 Kim et al.
D586,331 S * 2/2009 Francz D14/218
D587,238 S 2/2009 Xie
D600,679 S * 9/2009 Upham D14/217
D639,779 S 6/2011 Chen
D643,412 S * 8/2011 Brady D14/218
D645,352 S 9/2011 Bore
D645,846 S 9/2011 Mordechai

(Continued)

(**) Term: **15 Years**

OTHER PUBLICATIONS

(21) Appl. No.: **29/628,205**
(22) Filed: **Dec. 1, 2017**
(51) **LOC (12) Cl.** **14-01**
(52) **U.S. Cl.**
USPC **D14/204**
(58) **Field of Classification Search**
USPC D14/188, 204, 209.1, 210–215, 348, 349,
D14/352, 498–505; 181/143, 144, 148,
181/153, 157, 198, 199; 369/6–12;
381/300–303, 361–364, 366, 386–388
CPC H04R 1/02; H04R 1/021; H04R 1/025;
H04R 1/026; H04R 1/028; H04R 1/403;
H04R 1/2803; H04R 1/2834; H04R 5/02;
H04R 9/06; H04R 19/013; H04R 2400/00
See application file for complete search history.

“Artistic Design Meets Superior Sound with ZOLO Model Zero Speaker,” Cision PR Newswire, Jan. 8, 2018. Retrieved Jan. 22, 2018 from Internet: <<https://www.prnewswire.com/news-releases/artistic-design-meets-superior-sound-with-the-zolo-model-zero-speaker-300578754.html>>.

(Continued)

Primary Examiner — Derrick E Holland
Assistant Examiner — Janice Patyk
(74) *Attorney, Agent, or Firm* — Plumsea Law Group, LLC

(57) **CLAIM**

The ornamental design for a loudspeaker, as shown and described.

DESCRIPTION

FIG. 1 is a perspective view of a loudspeaker showing the new design;
FIG. 2 is a front elevational view thereof;
FIG. 3 is a rear elevational view thereof;
FIG. 4 is a side elevational view thereof;
FIG. 5 is an opposite side elevational view thereof;
FIG. 6 is a top view thereof; and,
FIG. 7 is a bottom view thereof.
The broken lines in the figures illustrate the portions of the design that form no part of the claimed design.

1 Claim, 7 Drawing Sheets

(56) **References Cited**
U.S. PATENT DOCUMENTS

4,057,980 A	11/1977	DeCesaris	
D487,276 S	3/2004	Cobigo	
D492,279 S	6/2004	Lee	
D509,059 S	9/2005	Hayes	
D509,183 S	9/2005	Solland et al.	
D515,129 S	2/2006	Robinson	
D515,556 S	2/2006	Allen	
D521,983 S *	5/2006	Kuo	D14/216
D522,995 S	6/2006	Iijima	
D536,665 S	2/2007	Solland	
D547,304 S *	7/2007	Francz	D14/218

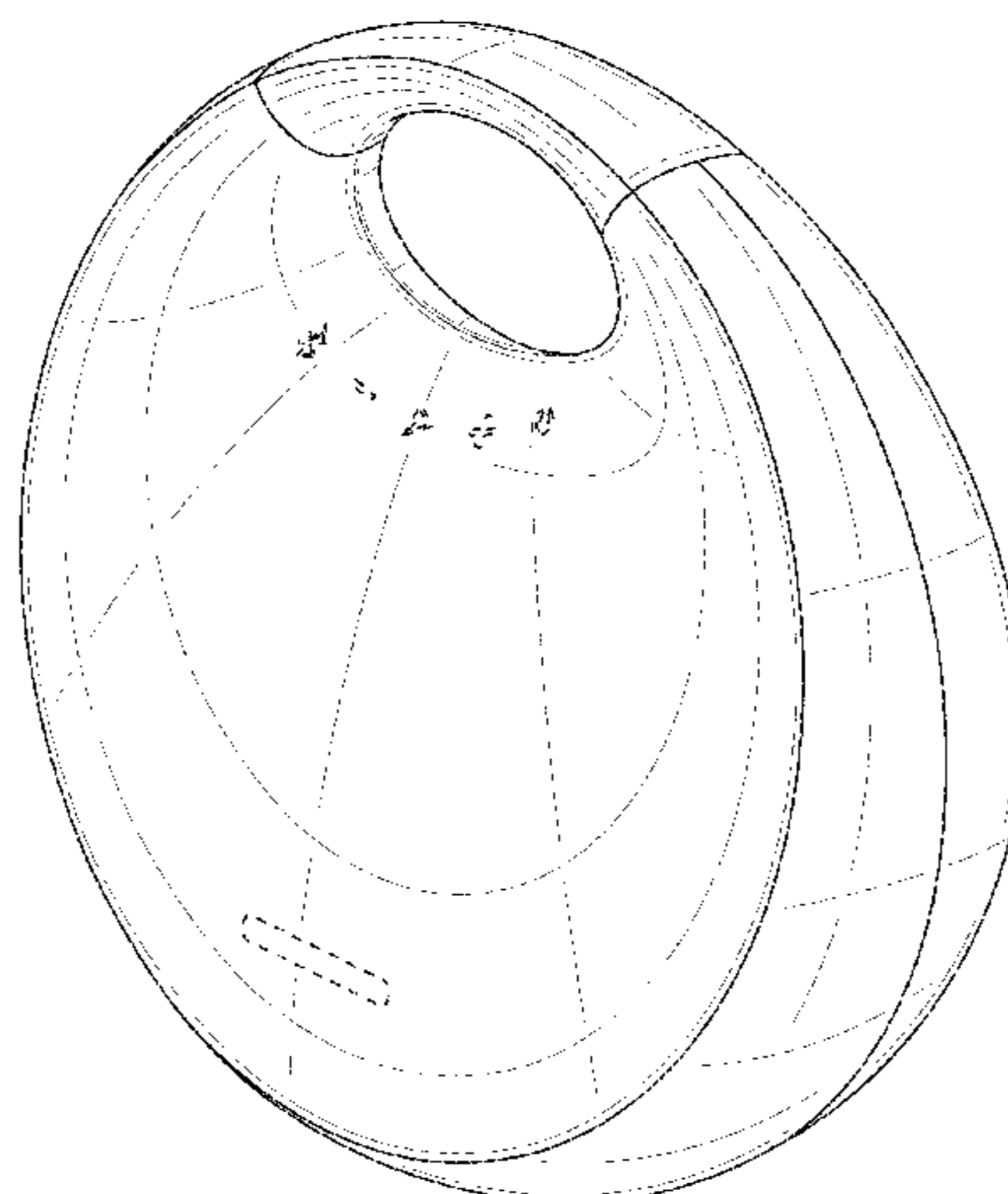

(56)

References Cited

U.S. PATENT DOCUMENTS

D655,686 S	3/2012	Miu	
D700,168 S	2/2014	Bolton	
D752,024 S	3/2016	Kachwalla	
D766,877 S	9/2016	Haase	
D769,227 S *	10/2016	Kass	D14/218
D798,840 S	10/2017	Tse	
D801,305 S	10/2017	Vaclavik et al.	
D801,309 S	10/2017	Ahn et al.	

OTHER PUBLICATIONS

“Audio Artistry—Model Zero,” Zolo Audio, Jan. 11, 2018. Retrieved Jan. 22, 2018 from Internet: <<https://web.archive.org/web/20180111160711/https://zoloaudio.com/pages/zero>>.

“Toot-A-Loop & Panasonic’s Craziest Color Portables (1971-1972),” 13 pages. Retrieved Apr. 13, 2018 from Internet: <<https://clickamericana.com/topics/science-technology/toot-a-loop-panasonics-craziest-color-radio-portables-1972>>.

“Phones—Western Electric Sculptura, Yellow 1978,” 2 pages. Retrieved Apr. 13, 2018 from Internet: <<http://web.eecs.umich.edu/~srs/Antiques/templ.php?pid=83&collection=Phones>>.

* cited by examiner

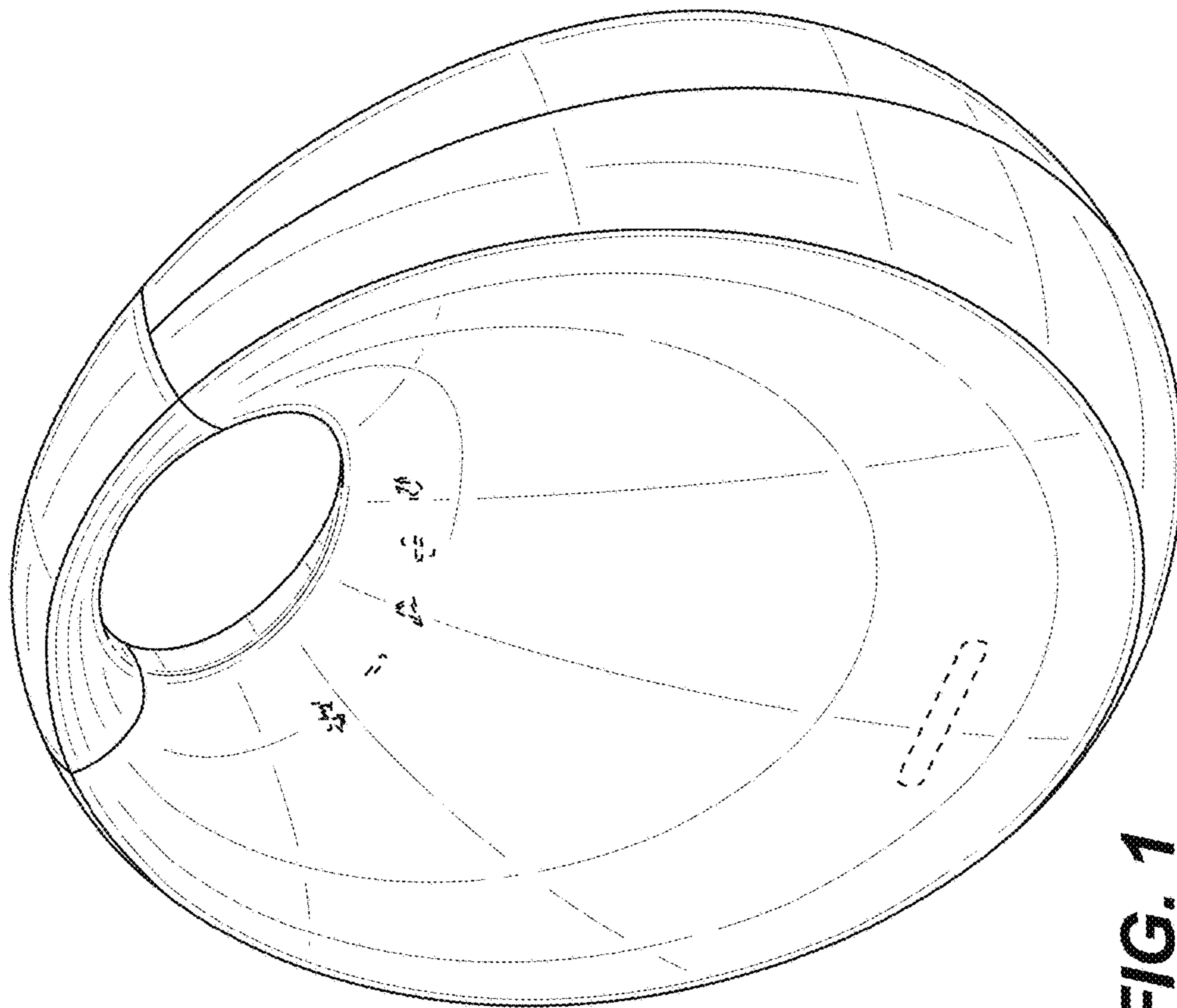

FIG. 1

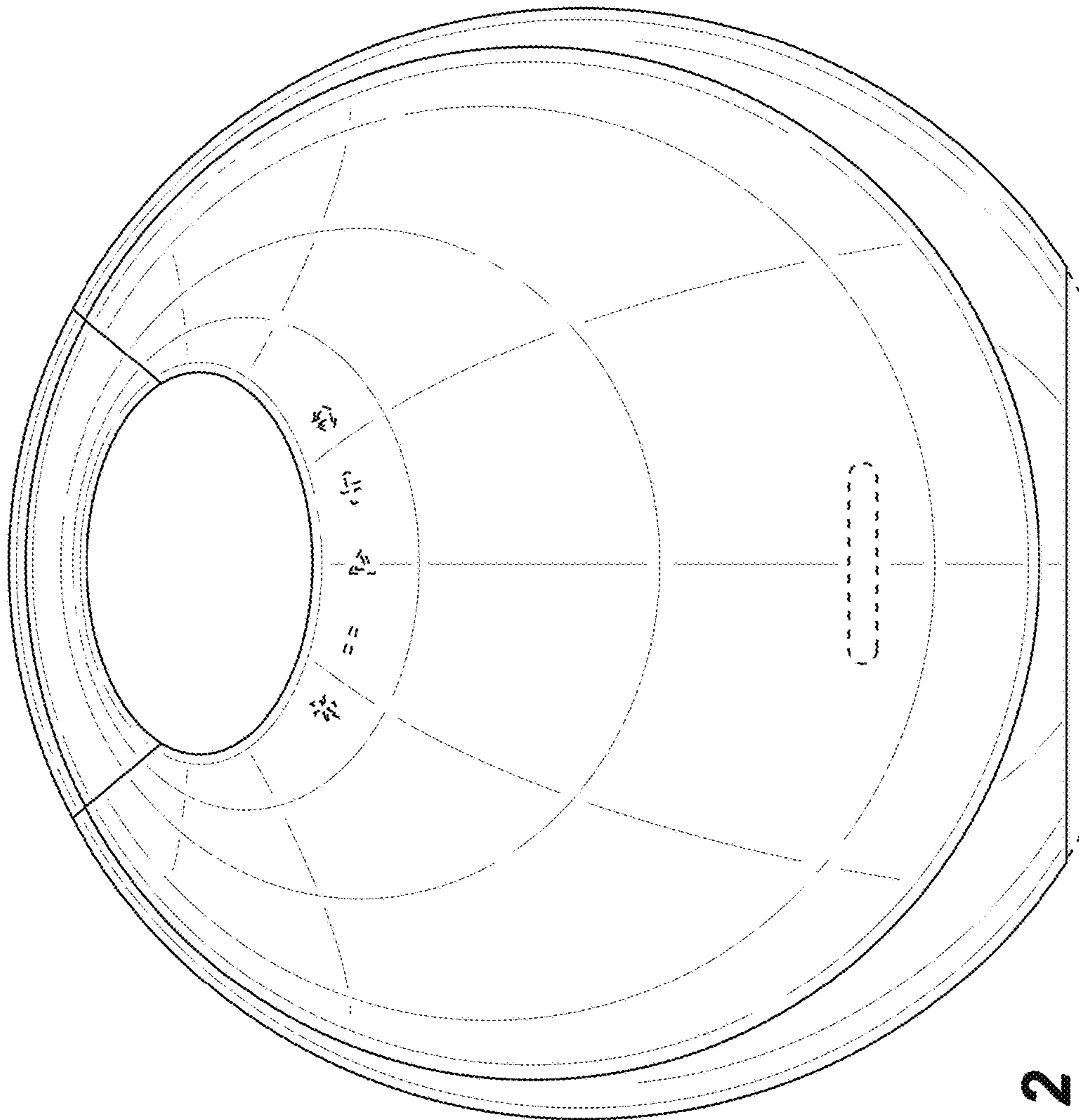

FIG. 2

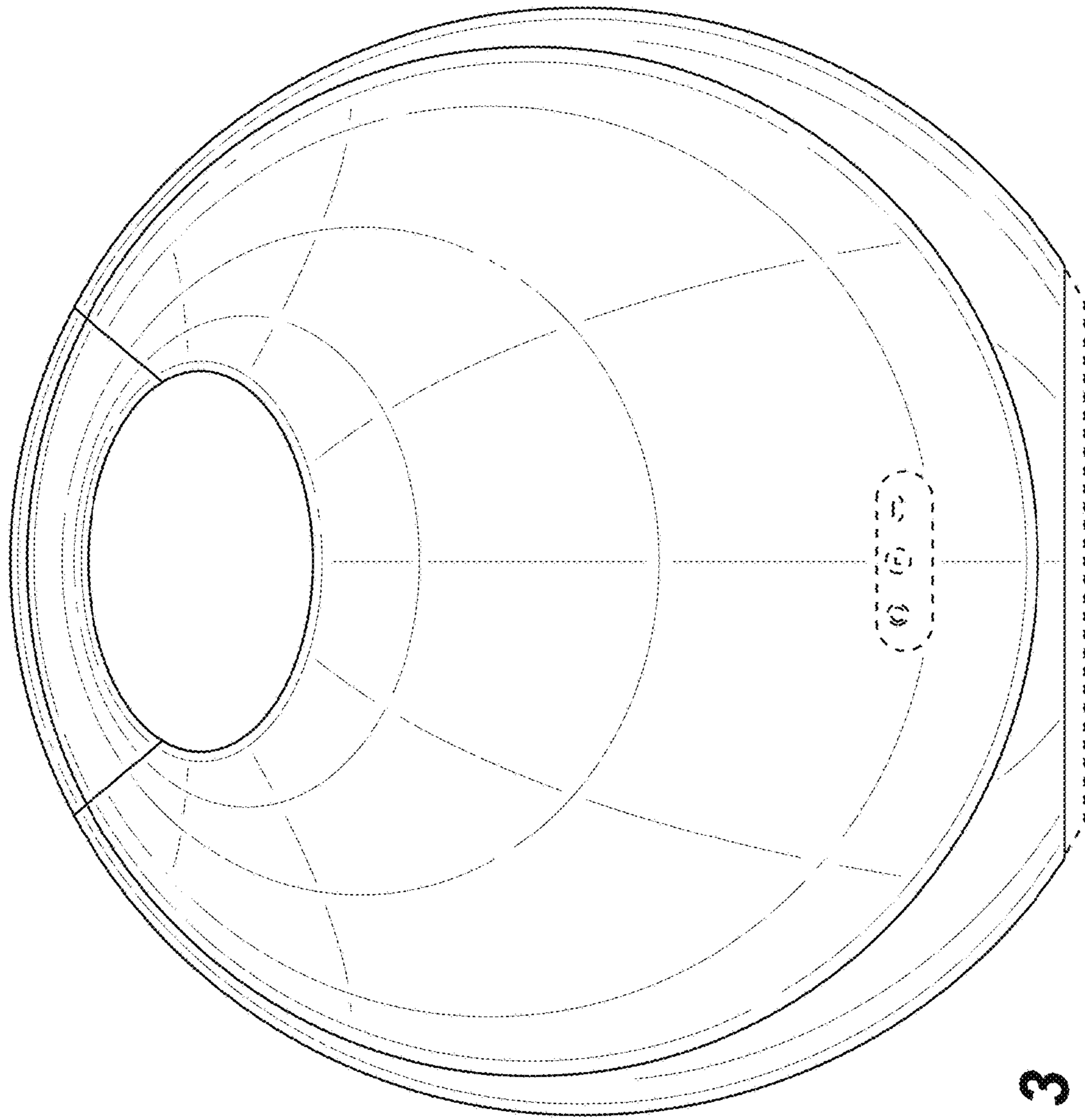

FIG. 3

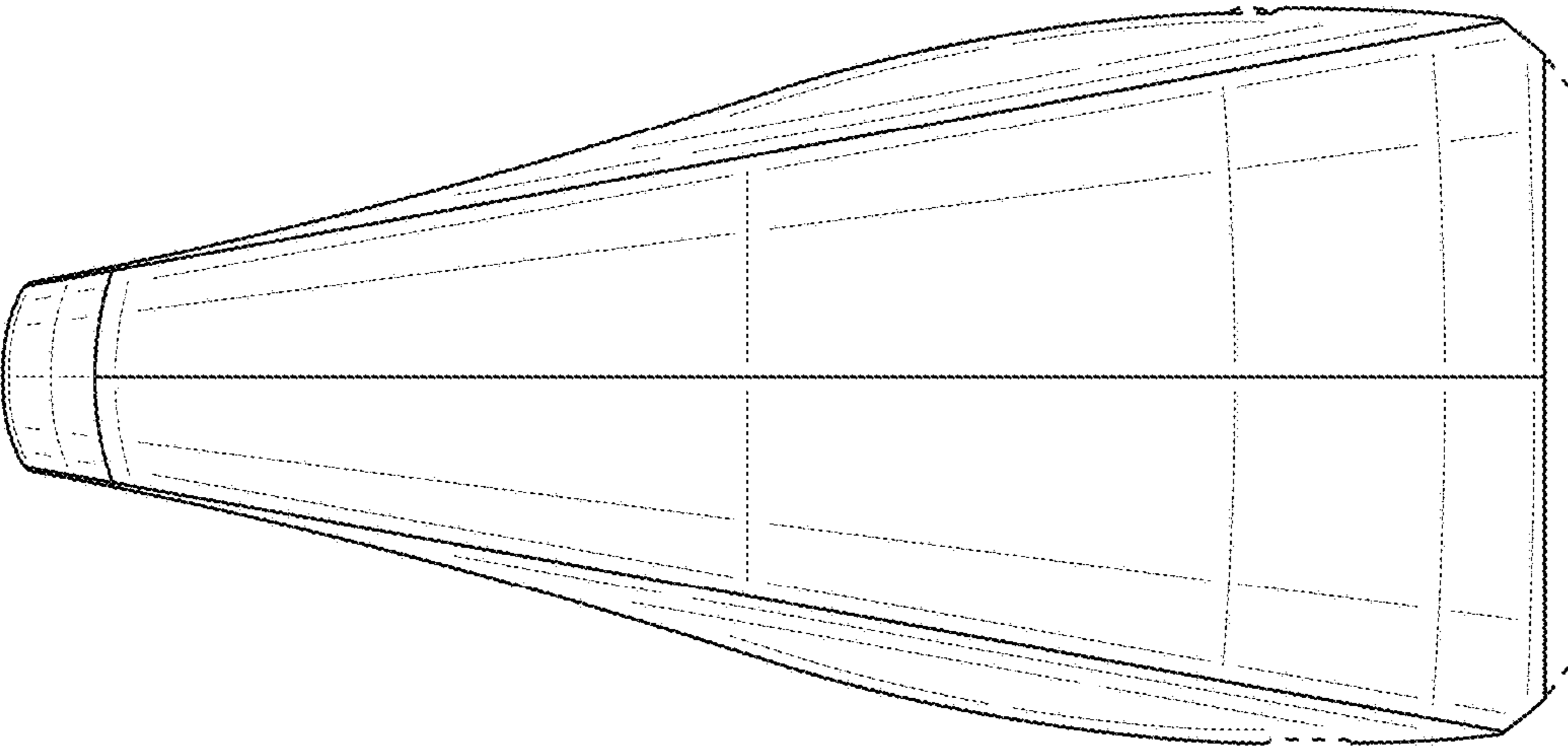

FIG. 4

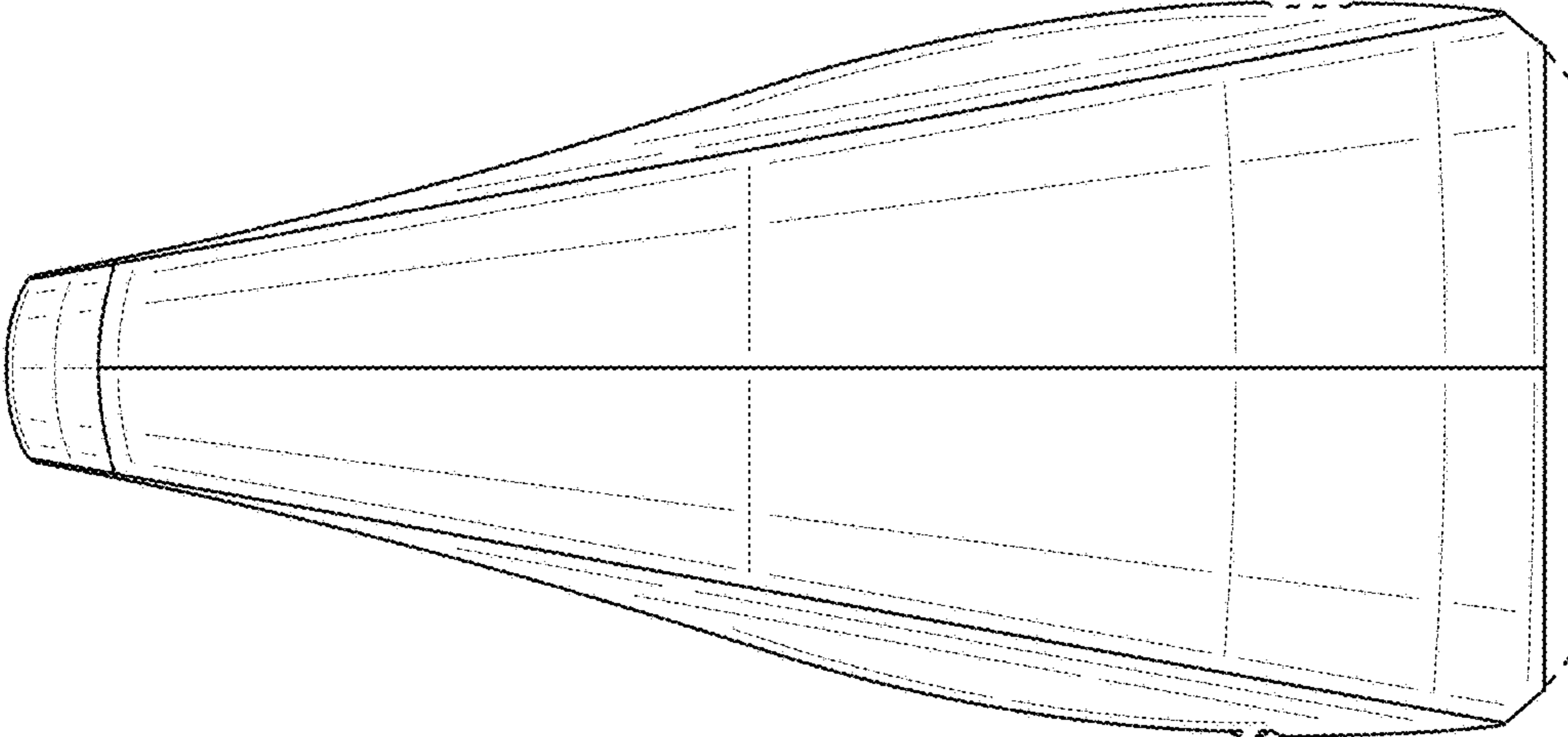

FIG. 5

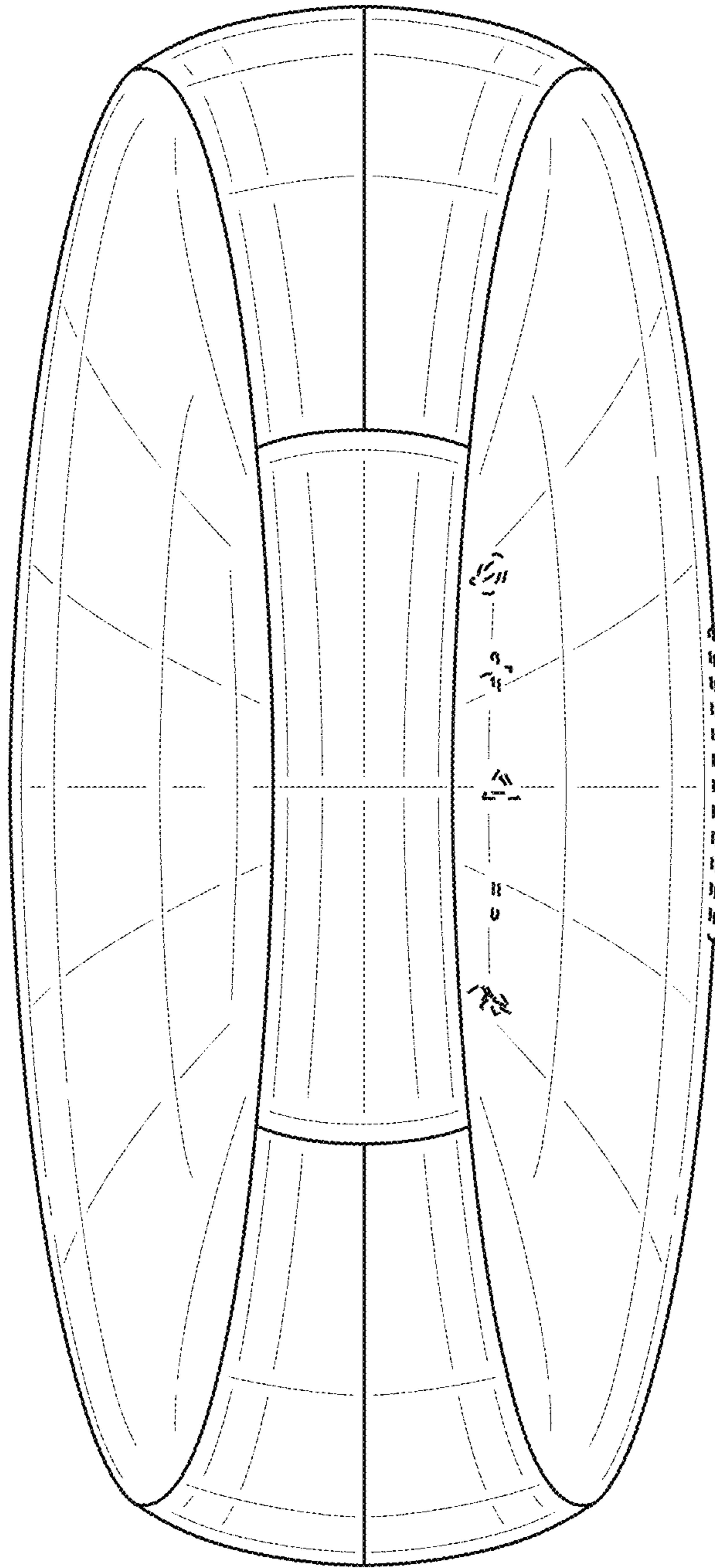

FIG. 6

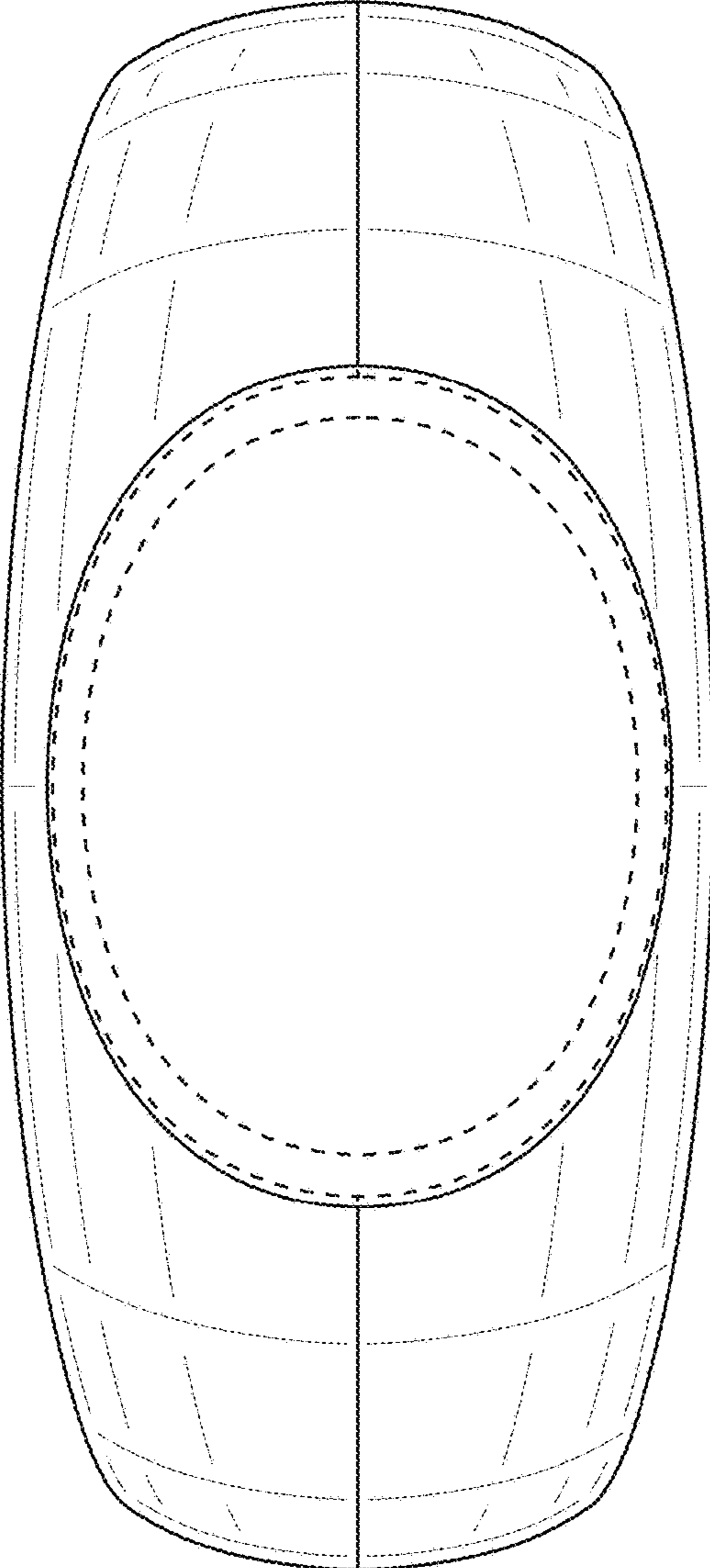

FIG. 7