



US00D869351S

(12) **United States Design Patent** (10) **Patent No.:** **US D869,351 S**
Duncan et al. (45) **Date of Patent:** **** Dec. 10, 2019**

- (54) **GRILLE SURROUND**
- (71) Applicants: **Jonathan S. Duncan**, Seattle, WA (US); **Amanda Koh**, Kenmore, WA (US); **Peter Vurpillat**, Seattle, WA (US); **Chris Small**, Seattle, WA (US); **John Jackson**, Sammamish, WA (US); **Rebecca Kern**, Kent, WA (US)
- (72) Inventors: **Jonathan S. Duncan**, Seattle, WA (US); **Amanda Koh**, Kenmore, WA (US); **Peter Vurpillat**, Seattle, WA (US); **Chris Small**, Seattle, WA (US); **John Jackson**, Sammamish, WA (US); **Rebecca Kern**, Kent, WA (US)
- (73) Assignee: **PACCAR INC**, Bellevue, WA (US)
- (**) Term: **15 Years**
- (21) Appl. No.: **29/644,072**
- (22) Filed: **Apr. 13, 2018**
- (51) **LOC (12) Cl.** **12-16**
- (52) **U.S. Cl.**
 USPC **D12/163**
- (58) **Field of Classification Search**
 USPC ... D14/141.1, 159, 218, 219, 220, 221, 222, D14/223, 224, 224.1, 225, 227, 228, 229, D14/259, 341, 344, 345, 299; D12/216, D12/190, 163
 CPC . H04R 1/00; H04R 1/02; H04R 1/326; H04R 1/406; H04R 1/083; H04R 1/222; H04R 1/1041; H04R 1/023; H04R 7/00; H04R 7/20; H04R 27/00; H04R 2201/00; H04R 2400/00; H04R 17/02; H04R 29/004; H04R 29/005; H04R 19/04; H04R 2420/07; H04R 2410/00; H04R 2410/01; H04R 5/02; G02B 27/01
 See application file for complete search history.

D250,018 S	10/1978	Barbera
D280,609 S	9/1985	Walter et al.
D284,180 S	6/1986	Abe
D284,366 S	6/1986	Abe
D311,711 S	10/1990	Marlowe et al.
D313,784 S	1/1991	Marlow et al.
D327,276 S	6/1992	Sorensen
D361,968 S	9/1995	Oyama
D366,638 S	1/1996	Tucker et al.
D366,640 S	1/1996	Tucker et al.
5,525,145 A	6/1996	Hodge
D378,812 S	4/1997	Aycock
D382,239 S	8/1997	Logan et al.
D382,841 S	8/1997	Norwood et al.
D382,844 S	8/1997	Norwood et al.
D389,108 S	1/1998	Norwood et al.
D395,860 S	7/1998	Meryman et al.
D396,028 S	7/1998	Needham
D396,677 S	8/1998	Sacco et al.
D400,835 S	11/1998	Le Quement et al.
D401,198 S	11/1998	Mueller et al.
D403,285 S	12/1998	Abalos et al.
D403,636 S	1/1999	Meryman et al.
D403,639 S	1/1999	Gale et al.
D406,636 S	1/1999	Meryman
D405,037 S	2/1999	Meryman et al.
D411,494 S	6/1999	Meryman et al.
D412,689 S	8/1999	Onopa
D412,874 S	8/1999	Meryman et al.
D421,734 S	3/2000	Sacco et al.
6,041,878 A	3/2000	Daniels et al.
D422,251 S	4/2000	Bader et al.
D424,993 S	5/2000	Farzam
D425,835 S	5/2000	Cook et al.
6,085,481 A	7/2000	Lee
D431,806 S	10/2000	Damon et al.
D433,655 S	11/2000	Sacco et al.
D433,980 S	11/2000	Conway et al.
D434,358 S	11/2000	Conway et al.
D435,816 S	1/2001	Delashaw et al.
D436,066 S	1/2001	Wagner
D436,563 S	1/2001	Delashaw et al.
D439,209 S	3/2001	Pfeiffer
D443,853 S	6/2001	Barraclough et al.
D445,383 S	7/2001	Price
D446,175 S	8/2001	Hoyle, Jr.
D447,099 S	8/2001	Tirey et al.
D450,277 S	11/2001	Onopa
D452,464 S	12/2001	Beigel
D455,381 S	4/2002	Maher
D460,023 S	7/2002	Beigel
D465,211 S	11/2002	Lawrence
D465,749 S	11/2002	Beigel

- (56) **References Cited**
- U.S. PATENT DOCUMENTS
- | | | |
|-------------|--------|---------------|
| D50,345 S | 2/1917 | Green |
| D50,346 S | 2/1917 | Green |
| 2,083,785 A | 6/1937 | Harrison, Jr. |

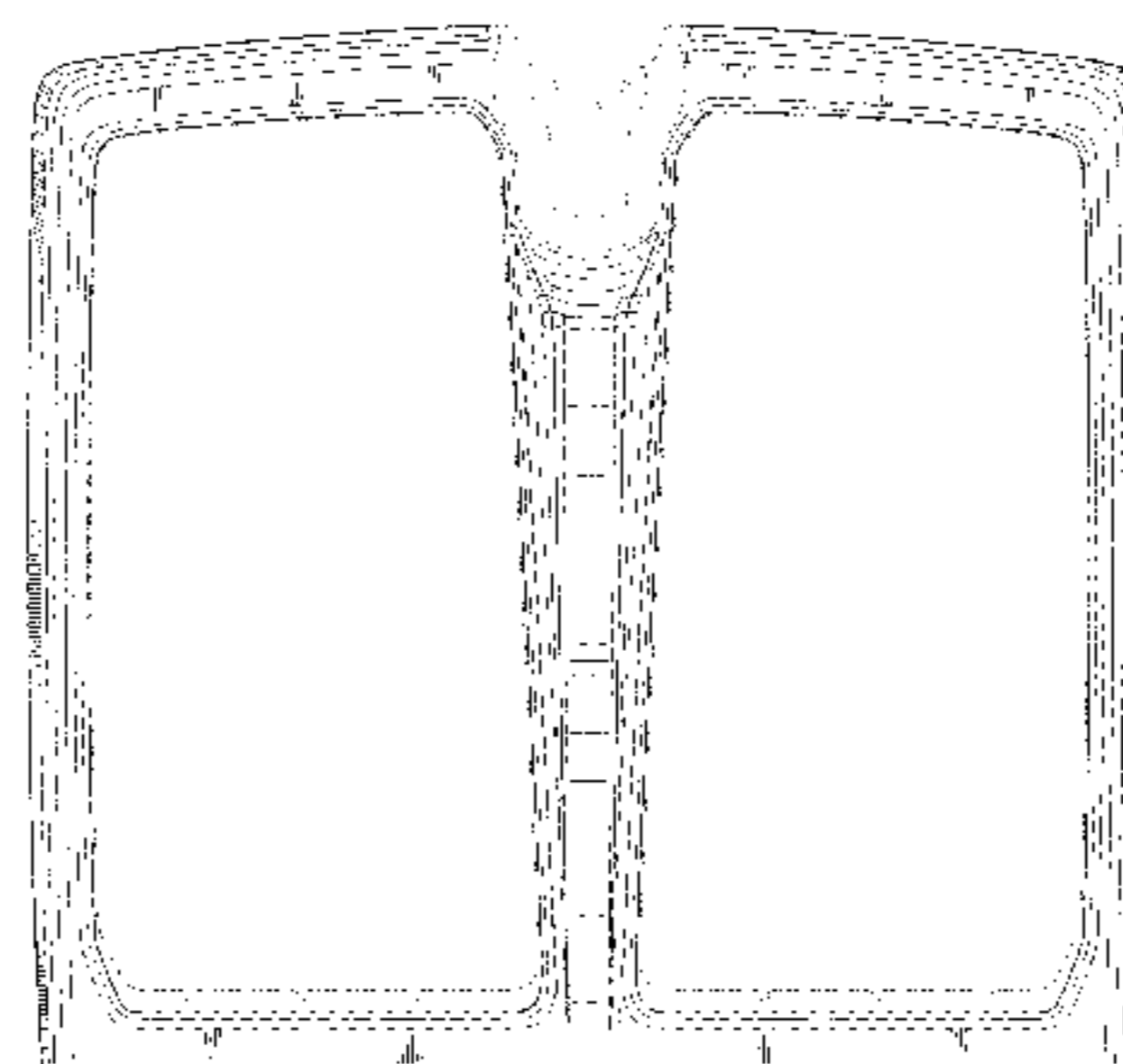
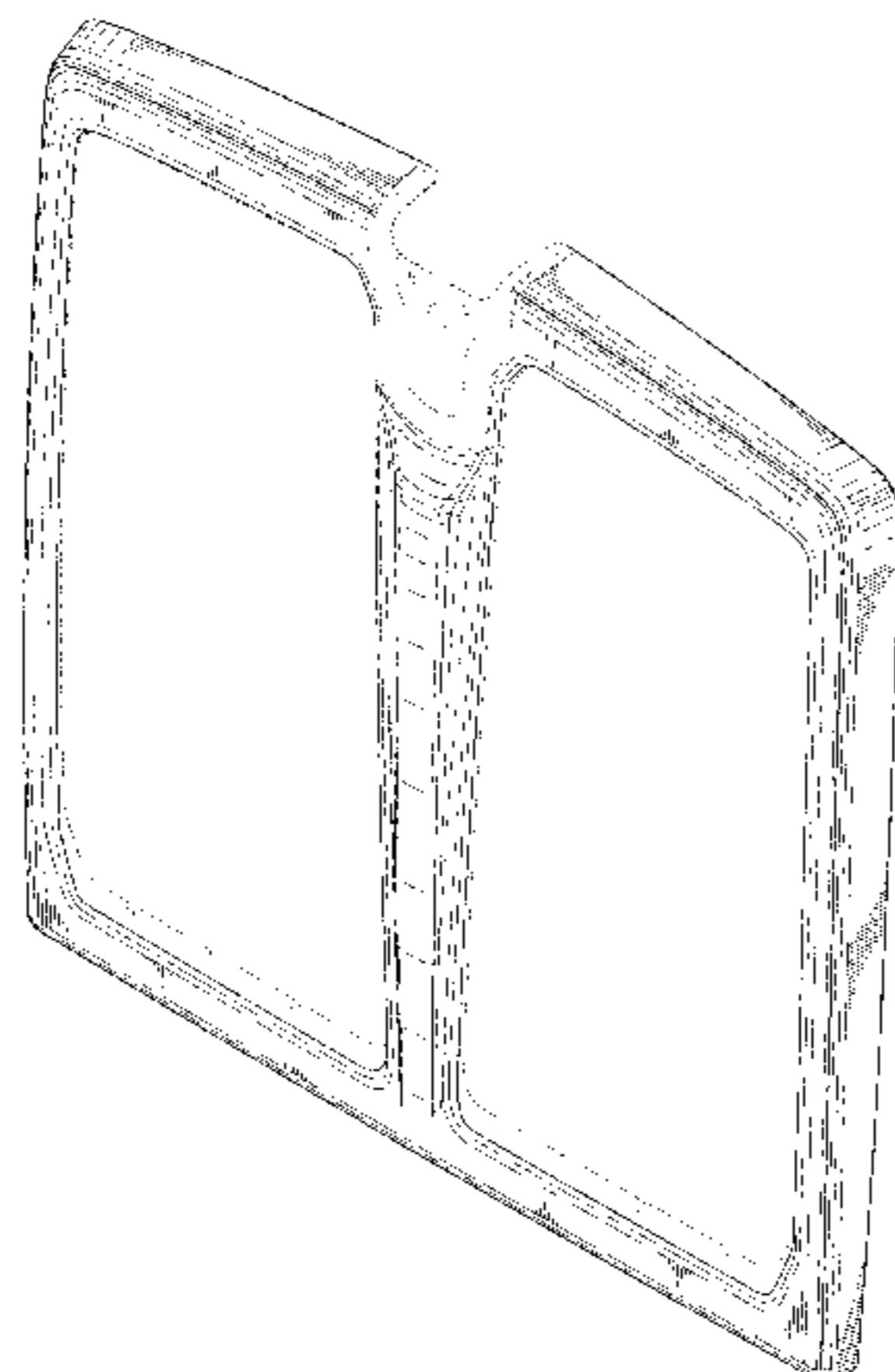

US D869,351 S

D466,450 S	12/2002	Maher et al.	D578,453 S	10/2008	Raghavendran et al.
D478,300 S	8/2003	Chiang	D580,312 S	11/2008	Opfer et al.
D479,166 S	9/2003	Tanaka et al.	D582,716 S	12/2008	Averty
D482,993 S	12/2003	Conway et al.	D588,512 S	3/2009	Raghavendran et al.
D484,077 S	12/2003	Conway et al.	D591,209 S	4/2009	Camacho et al.
D486,102 S	2/2004	Perfetti et al.	D592,561 S	5/2009	Otto et al.
D488,112 S	4/2004	Satou	D592,574 S	5/2009	Larson
D490,749 S	6/2004	Satou	D597,003 S	7/2009	Yamazaki et al.
D491,858 S	6/2004	Velazco	D601,932 S	10/2009	Rosen et al.
D492,801 S	7/2004	Metros et al.	D604,209 S	11/2009	Chae
D492,921 S	7/2004	Perfetti et al.	D605,986 S	12/2009	Raghavendran et al.
D493,759 S	8/2004	Pfeiffer	D606,339 S	12/2009	Jacobson et al.
D494,514 S	8/2004	Pfeiffer	7,677,650 B2	3/2010	Huttenlocher
D494,900 S	8/2004	Satou	D617,693 S	6/2010	Klobe
D495,633 S	9/2004	Chiang	D618,057 S	6/2010	Ormrod et al.
D496,890 S	10/2004	Metros et al.	D619,941 S	7/2010	Krauss
D497,581 S	10/2004	Conway et al.	D621,754 S	8/2010	Angelo
D498,186 S	11/2004	Iwai	D622,188 S	8/2010	Angelo et al.
D502,897 S	3/2005	Delashaw et al.	D627,692 S	11/2010	Cheng
D502,901 S	3/2005	Delashaw et al.	D631,800 S	2/2011	Peltola et al.
D502,904 S	3/2005	Delashaw et al.	D632,224 S	2/2011	Peltola et al.
D504,642 S	5/2005	Perfetti et al.	D632,234 S	2/2011	Peltola et al.
D511,727 S	11/2005	Shaw et al.	D634,093 S	3/2011	Wagner
D512,666 S	12/2005	Chiang	D635,567 S *	4/2011	Rashid D14/341
D513,212 S	12/2005	Pfeiffer et al.	D635,897 S	4/2011	Frei et al.
D514,483 S	2/2006	Chiang	7,922,235 B1	4/2011	Smith
D515,474 S	2/2006	Wu	D640,175 S	6/2011	Villamizar et al.
D517,965 S	3/2006	Metros et al.	D643,352 S	8/2011	Hjorten et al.
D518,761 S	4/2006	Chiang	D645,797 S	9/2011	Beigel et al.
D519,426 S	4/2006	Ikeda	D647,016 S	10/2011	Medina et al.
D522,935 S	6/2006	Marchese et al.	D647,827 S	11/2011	Medina et al.
D522,936 S	6/2006	Beigel et al.	D647,832 S	11/2011	Medina et al.
D523,791 S	6/2006	Pfeiffer	D650,781 S *	12/2011	Rashid D14/341
D523,793 S	6/2006	Beigel et al.	D651,142 S	12/2011	Fushimi
D524,204 S	7/2006	Beigel	D654,401 S	2/2012	Peltola et al.
D526,605 S	8/2006	Chung	D654,417 S	2/2012	Peltola et al.
D526,941 S	8/2006	Yamashita	D655,226 S	3/2012	Hanson et al.
D527,694 S	9/2006	Chung	D656,435 S	3/2012	Lambri et al.
D528,050 S	9/2006	McCuller et al.	D669,303 S	10/2012	Garman
D530,247 S	10/2006	Angelo	D671,938 S *	12/2012	Hsu D14/341
D531,554 S	11/2006	Conkey et al.	D683,668 S	6/2013	Thurber
D531,555 S	11/2006	Hooper	D685,294 S	7/2013	Hanson et al.
D531,947 S	11/2006	Angelo et al.	D686,122 S	7/2013	Peltola et al.
D532,350 S	11/2006	Angelo et al.	D690,242 S	9/2013	Conway et al.
D532,352 S	11/2006	Angelo et al.	D690,632 S	10/2013	Peltola et al.
D535,431 S	1/2007	Roland	D691,072 S	10/2013	Cheng
D535,591 S	1/2007	Schiavone	D692,805 S	11/2013	Morioka
D538,207 S	3/2007	Pfeiffer	D699,650 S	2/2014	Peltola et al.
D539,194 S	3/2007	Moses	D699,651 S	2/2014	Peltola et al.
D539,704 S	4/2007	Angelo et al.	D702,609 S	4/2014	Hovind et al.
D540,725 S	4/2007	Gunter et al.	D702,615 S	4/2014	Conway et al.
D540,727 S	4/2007	Elliott et al.	D706,577 S	6/2014	Funnell, II et al.
D545,250 S	6/2007	Angelo et al.	D706,690 S	6/2014	Peltola et al.
D545,251 S	6/2007	Angelo et al.	D707,160 S	6/2014	Peltola et al.
D545,254 S	6/2007	Angelo et al.	D707,161 S	6/2014	Peltola et al.
D545,255 S	6/2007	Angelo et al.	D707,163 S	6/2014	Peltola et al.
D545,728 S	7/2007	Golden et al.	D708,104 S	7/2014	Conway et al.
D545,730 S	7/2007	Lee et al.	D708,553 S	7/2014	Conway et al.
D545,735 S	7/2007	Angelo et al.	D708,985 S	7/2014	Peltola et al.
D549,072 S	8/2007	Davidson	D708,986 S	7/2014	Conway et al.
D551,133 S	9/2007	Angelo	D708,989 S	7/2014	Peltola et al.
D551,599 S	9/2007	Simons et al.	D708,990 S	7/2014	Conway et al.
D551,600 S	9/2007	Simons et al.	D708,992 S	7/2014	Ito et al.
D560,575 S	1/2008	Simons et al.	D708,999 S	7/2014	Conway et al.
D560,582 S	1/2008	Simons et al.	D709,000 S	7/2014	Peltola et al.
D560,583 S	1/2008	Simons et al.	D709,001 S	7/2014	Conway et al.
D562,196 S	2/2008	Saito	D709,406 S	7/2014	Conway et al.
D563,281 S	3/2008	Simons et al.	D709,407 S	7/2014	Conway et al.
D563,849 S	3/2008	Medina et al.	D709,408 S	7/2014	Peltola et al.
D563,850 S	3/2008	Rosen et al.	D709,410 S	7/2014	Conway et al.
D563,851 S	3/2008	Rosen et al.	D709,411 S	7/2014	Peltola et al.
D563,852 S	3/2008	Rosen et al.	D709,421 S	7/2014	Conway et al.
D563,853 S	3/2008	Rosen et al.	D709,422 S	7/2014	Peltola et al.
D564,427 S	3/2008	Beigel et al.	D709,423 S	7/2014	Peltola et al.
D566,635 S	4/2008	Rosen et al.	D709,424 S	7/2014	Conway et al.
D567,355 S	4/2008	Zakula et al.	D709,425 S	7/2014	Conway et al.
D571,696 S	6/2008	Rosen et al.	D709,727 S	7/2014	Cloutier et al.
D575,688 S	8/2008	Miyata et al.	D710,765 S	8/2014	Conway et al.
D577,316 S	9/2008	Rosen et al.	D711,789 S	8/2014	Sahara et al.

8,800,703 B2	8/2014	Miller et al.	
D714,195 S	9/2014	Conway et al.	
D722,934 S	2/2015	Conway et al.	
D729,705 S	5/2015	Gunnarson et al.	
D729,709 S	5/2015	Conway et al.	
D742,873 S *	11/2015	Ahn	D14/341
D746,200 S	12/2015	Leetz	
D751,470 S	3/2016	Buck et al.	
D756,855 S	5/2016	Leetz et al.	
D758,253 S	6/2016	Brzustowicz et al.	
D759,800 S	6/2016	Adrian et al.	
D770,335 S	11/2016	Walterscheid et al.	
D781,188 S	3/2017	Wolff et al.	
D782,381 S	3/2017	Conway et al.	
D784,077 S	4/2017	Zemel et al.	
D786,742 S	5/2017	Ito et al.	
D787,384 S	5/2017	Ito et al.	
D787,476 S *	5/2017	Lee	D14/218
D789,147 S	6/2017	Nilssen	
D793,384 S *	8/2017	Park	D14/341
D795,761 S	8/2017	Ito et al.	
D799,677 S	10/2017	Jonas et al.	
D803,730 S	11/2017	Ito et al.	
D805,981 S	12/2017	Conway et al.	
D826,931 S *	8/2018	Chang	D14/341
D835,011 S *	12/2018	Peltola	D12/163
2003/0179541 A1 *	9/2003	Sullivan	G06F 1/1616 361/679.29
2013/0025954 A1	1/2013	Miller et al.	

FOREIGN PATENT DOCUMENTS

CN	201607029 U	10/2010
CN	202511694 U	10/2012
CN	103423850 A	12/2013
CN	205971189 U	2/2017
CN	206131375 U	4/2017
DE	10238445 A1	3/2004
EP	3199395 A1	8/2017
GB	2513202 A	10/2014
JP	2009-83740 A	4/2009

OTHER PUBLICATIONS

Kenworth debuts new W990 model, posted Sep. 28, 2018 [online], retrieved Feb. 28, 2019, retrieved from internet, <<https://www.fleetowner.com/equipment/kenworth-debuts-new-w990-model>>.*

“T270 Class 6 and T370 Class 7 Hybrid,” Kenworth Truck Company, Kirkland, Washington, 2009, 6-page brochure.

“T270 Class 6 and T370 Class 7,” Kenworth Truck Company, Kirkland, Washington, 2008, 6-page brochure.

“T270 Class 6 and T370 Class 7,” Kenworth Truck Company, Kirkland, Washington, 2009, 6-page brochure.

“T300,” Kenworth Truck Company, Kirkland, Washington, 1994, 4-page brochure.

“T300,” Kenworth Truck Company, Kirkland, Washington, 1997, 5-page brochure.

“T300,” Kenworth Truck Company, Kirkland, Washington, 2001, 16-page brochure.

“T300,” Kenworth Truck Company, Kirkland, Washington, 2005, 16-page brochure.

“T400B and T450B,” Kenworth Truck Company, Kirkland, Washington, 1992, 10-page brochure.

“T440,” Kenworth Truck Company, Kirkland, Washington, 2010, 2-page brochure.

“T440,” Kenworth Truck Company, Kirkland, Washington, 2010, 6-page brochure.

“T470,” Kenworth Truck Company, Kirkland, Washington, 2010, 6-page brochure.

“T470H,” Kenworth Truck Company, Kirkland, Washington, 2009, 2-page brochure.

“T600,” Kenworth Truck Company, Kirkland, Washington, 1996, 7-page brochure.

“T600,” Kenworth Truck Company, Kirkland, Washington, 2002, 28-page brochure.

“T600,” Kenworth Truck Company, Kirkland, Washington, 2005, 24-page brochure.

“T600, Ten Years of Innovation,” Kenworth Truck Company, Kirkland, Washington, 1995, 6-page brochure.

“T600A,” Kenworth Truck Company, Kirkland, Washington, 1985, 10-page brochure.

“T660,” Kenworth Truck Company, Kirkland, Washington, 2007, 36-page brochure.

“T660,” Kenworth Truck Company, Kirkland, Washington, 2009, 36-page brochure.

“T700,” Kenworth Truck Company, Kirkland, Washington, 2010, 6-page brochure.

“T800B,” Kenworth Truck Company, Kirkland, Washington, 1993, 8-page brochure.

“T800,” Kenworth Truck Company, Kirkland, Washington, 1996, 7-page brochure.

“T800,” Kenworth Truck Company, Kirkland, Washington, 2002, 32-page brochure.

“T800,” Kenworth Truck Company, Kirkland, Washington, 2003, 32-page brochure.

“T800,” Kenworth Truck Company, Kirkland, Washington, 2005, 28-page brochure.

“T800,” Kenworth Truck Company, Kirkland, Washington, 2009, 28-page brochure.

“The Working Class,” Peterbilt Motors Company, Newark, California, Sep. 1976, 6-page brochure.

“The World’s Best,” Kenworth Truck Company, Kirkland, Washington, 1992, 12-page brochure.

“Unibilt™ Cab Sleeper System,” Peterbilt Motors Company, Denton Texas, Aug. 1994, 6-page brochure.

“W900,” Kenworth Truck Company, Kirkland, Washington, 1996, 7-page brochure.

“W900,” Kenworth Truck Company, Kirkland, Washington, 2002, 32-page brochure.

“W900,” Kenworth Truck Company, Kirkland, Washington, 2005, 28-page brochure.

“W900,” Kenworth Truck Company, Kirkland, Washington, 2009, 28-page brochure.

“W900L Aero Cab,” Kenworth Truck Company, Kirkland, Washington, 1994, 2-page brochure.

“T680,” Kenworth Truck Company, Kirkland, Washington, 2013, 34-page brochure.

“T680,” Kenworth Truck Company, Kirkland, Washington, 2016, 34-page brochure.

“T880,” Kenworth Truck Company, Kirkland, Washington, 2017, 32-page brochure.

“Model 579,” Peterbilt Motors Company, Denton, Texas, 2013, 13-page brochure.

“Model 587,” Peterbilt Motors Company, Denton, Texas, 2011, 4-page brochure.

“Medium-Duty,” Peterbilt Motors Company, Denton, Texas, 2013, 9-page brochure.

“On-Highway,” Peterbilt Motors Company, Denton, Texas, 2013, 13-page brochure.

“Vocational,” Peterbilt Motors Company, Denton, Texas, 2013, 11-page brochure.

“1960 MG Magnette Mark III 4 Door (Rare Find!)—Sold, Sold, Sold!!!” Happy Carz.com, <<http://www.happycarz.com/showroom/1960-mg-magnette-mark-iii-4-door-rare-find/>>.

“2-Pc RC1 Classic Design Mesh Grille,” CarID, <<https://www.carid.com/2011-dodge-ram-grill/royally-core-rc-classic-design-grilles-561858656.html>>.

“AeroCab,” Kenworth Truck Company, Kirkland, Washington, 1993, 5-page brochure.

“AeroCab,” Kenworth Truck Company, Kirkland, Washington, as early as 1995, 3-page brochure.

“AG130 Front Air Suspension,” Kenworth Truck Company, Kirkland, Washington, 2008, 2-page brochure.

“C500B,” Kenworth Truck Company, Kirkland, Washington, as early as 1990, 4-page brochure.

“Cabovers,” Peterbilt Motors Company, Newark, California, as early as 2000, 7-page brochure.

“Cartek Auto Billet Grilles and ABS Grille Shells,” Tuned by Matrix, <http://www.tunedbymatrix.com/Auto_Shells/300.php>.

“Class Pays, Construction Trucks,” Peterbilt Motors Company, Denton, Texas, Nov. 2003, 16-page brochure.

“Class Pays, Ergonomic Dash,” Peterbilt Motors Company, Denton, Texas, Mar. 2000, 2-page brochure.

“Class Pays,” Medium Duty, Peterbilt Motors Company, Denton, Texas, Sep. 2000, 12-page brochure.

“Class Pays,” Peterbilt Motors Company, Denton, Texas, Nov. 1998, 10-page brochure.

“Class Pays,” Peterbilt Motors Company, Denton, Texas, Sep. 1997, 10-page brochure.

“Class Pays, Platinum Interior,” Peterbilt Motors Company, Denton, Texas, May 2005, 4-page brochure.

“Class Pays, Refuse Trucks,” Peterbilt Motors Company, Denton, Texas, Sep. 2003, 2-page brochure.

“Class Pays, Truck Models,” Peterbilt Motors Company, Denton, Texas, Mar. 2005, 24-page brochure.

“Construction Trucks,” Canadian Kenworth Truck, Mississauga, Ontario, Canada, Jul. 1990, 16-page brochure.

“Daimler will kill the Maybach brand in 2013 and replace it with S600 Pullman,” 4WheelsNews, Nov. 25, 2011, <<https://www.4wheelsnews.com/auto/daimler-will-kill-the-maybach-brand-in-2013-and-replace-it-with-s600-pullma-18746-g-60963.html>>.

“Installing a Pines Winterfront Grille on a 1932 Ford Vicky,” Seabright Hot Rods, Sep. 5, 2016, <<http://www.seabrighthotrods.com/?p=718>>.

“Interiors,” Kenworth Truck Company, Kirkland, Washington, 2005, 16-page brochure.

“Jaguar XJ Series X300 Parts—Radiator Grille and Badges,” Jaguar Classic Parts, <<https://www.jaguarclassicparts.com/uk/jaguar-xj-x300-parts/exterior-fillings-and-sunroof/grilles/radiator-grille-and-badges>>.

“K100E,” Kenworth Truck Company, Kirkland, Washington, 1984, 8-page brochure.

“Kenworth Truck Models,” Kenworth Truck Company, Kirkland, Washington, 2010, 16-page brochure.

“MGA Mesh Grille Conversion Kit,” The MG Experience, Apr. 20, 2009, <<http://www.mgexp.com/phorum/read.php?72,1089209>>.

“Model 320,” Peterbilt Motors Company, Denton, Texas, May 1996, 2-page brochure.

“Model 330,” Peterbilt Motors Company, Denton, Texas, Oct. 1997, 3-page brochure.

“Model 357 Heavy Haul,” Peterbilt Motors Company, Denton, Texas, Mar. 2005, 2-page brochure.

“Model 357 Standard Specifications,” Peterbilt Motors Company, Newark, California, Sep. 1986, 6-page brochure.

“Model 357, New Sloped Hood,” Peterbilt Motors Company, Denton, Texas, May 2002, 2-page brochure.

“Model 357,” Peterbilt Motors Company, Denton, Texas, May 1994, 3-page brochure.

“Model 357-115,” Peterbilt Motors Company, Denton, Texas, Mar. 2005, 2-page brochure.

“Model 362,” Peterbilt Motors Company, Newark, California, 1985, 8-page brochure.

“Model 375 Standard Specifications,” Peterbilt Motors Company, Newark, California, Sep. 1986, 6-page brochure.

“Model 377A/E” Peterbilt Motors Company, Denton, Texas, Aug. 1997, 2-page brochure.

“Model 377A/E” Peterbilt Motors Company, Denton, Texas, Jan. 1995, 6-page brochure.

“Model 378,” Peterbilt Motors Company, Denton, Texas, Mar. 1998, 3-page brochure.

“Model 379,” Peterbilt Motors Company, Denton, Texas, Apr. 2005, 2-page brochure.

“Model 379,” Peterbilt Motors Company, Denton, Texas, Mar. 1996, 5-page brochure.

“Model 385,” Peterbilt Motors Company, Denton, Texas, Oct. 1996, 5-page brochure.

“Model 387,” Peterbilt Motors Company, Denton, Texas, Oct. 2002, 2-page brochure.

“PACCAR Engines, 2010 Medium Duty Engines,” PACCAR Inc, Bellevue, Washington, 2010, 6-page brochure.

“PACCAR MX,” PACCAR Inc, Bellevue, Washington, 2010, 4-page brochure.

“Peterbilt Brochure,” Feb. 2011, <<http://web.archive.org/web/20060212234257/http://www.peterbilt.com/Full-line.htm>> [retrieved Nov. 22, 2013].

“Peterbilt Parts & Accessories,” Peterbilt Motors Company, Denton, Texas, catalog, as early as 2000, 52-page brochure.

“Rest with Class,” Peterbilt Motors Company, Newark, California, Apr. 1978, 4-page brochure.

“Studio Sleeper,” Kenworth Truck Company, Kirkland, Washington, 1993, 5-page brochure.

“T170 Class 5,” Kenworth Truck Company, Kirkland, Washington, 2008, 4-page brochure.

“T2000,” Kenworth Truck Company, Kirkland, Washington, 1999, 20-page brochure.

“T2000,” Kenworth Truck Company, Kirkland, Washington, 2002, 20-page brochure.

“T2000,” Kenworth Truck Company, Kirkland, Washington, 2005, 20-page brochure.

* cited by examiner

Primary Examiner — Barbara Fox

Assistant Examiner — Messina L Smith

(74) *Attorney, Agent, or Firm* — Christensen O’Connor Johnson Kindness PLLC

(57)

CLAIM

The ornamental design for a grille surround, as shown and described.

DESCRIPTION

FIG. 1 is a perspective view of a grille surround showing our new design;
 FIG. 2 is a front view of the grille surround shown in FIG. 1;
 FIG. 3 is a top view of the grille surround shown in FIG. 1;
 FIG. 4 is a right side view of the grille surround shown in FIG. 1; and,
 FIG. 5 is a left side view of the grille surround shown in FIG. 1.
 The broken lines in the drawings depict portions of the grille surround that form no part of the claimed design.

1 Claim, 3 Drawing Sheets

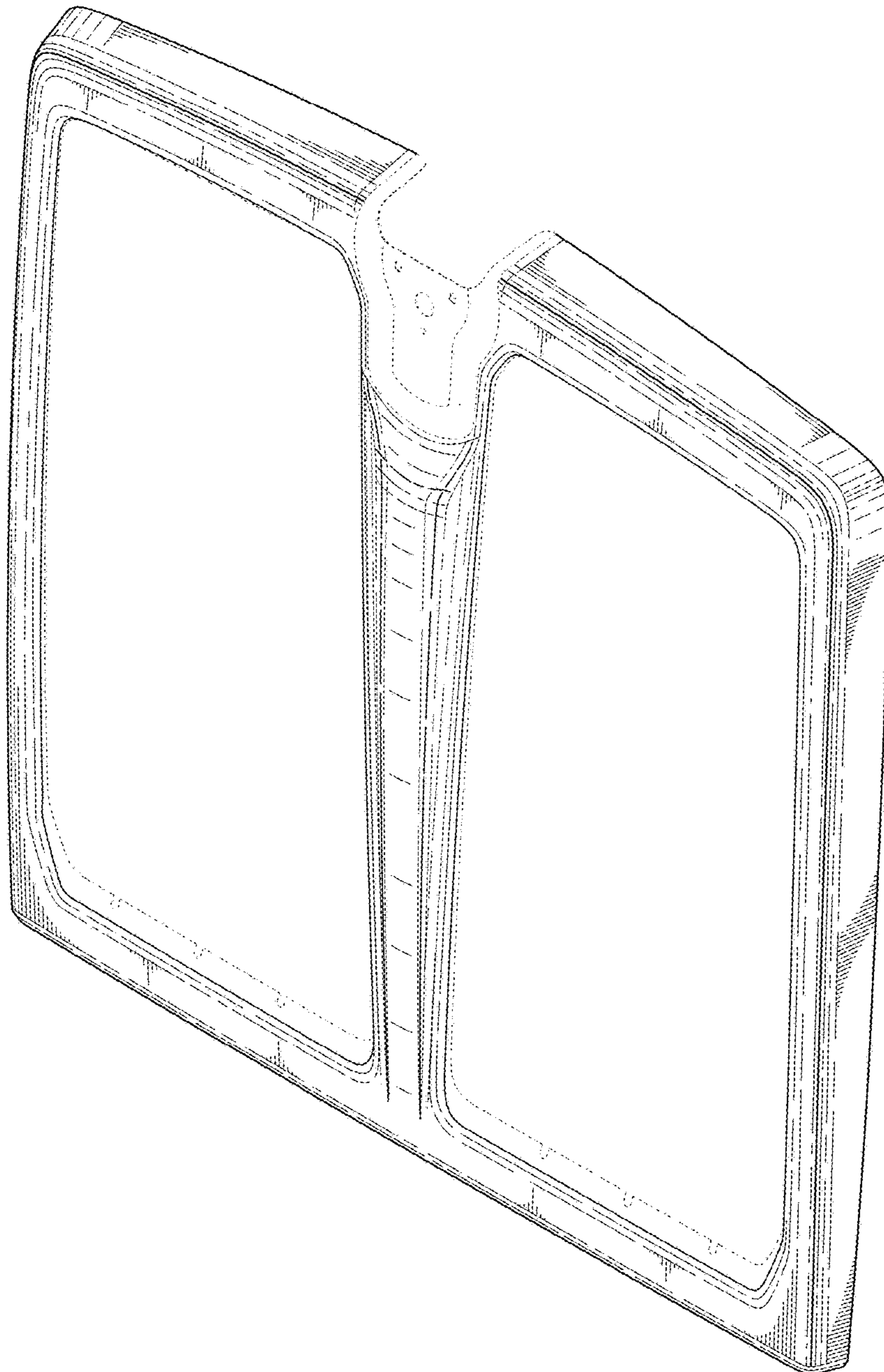

Fig. 1.

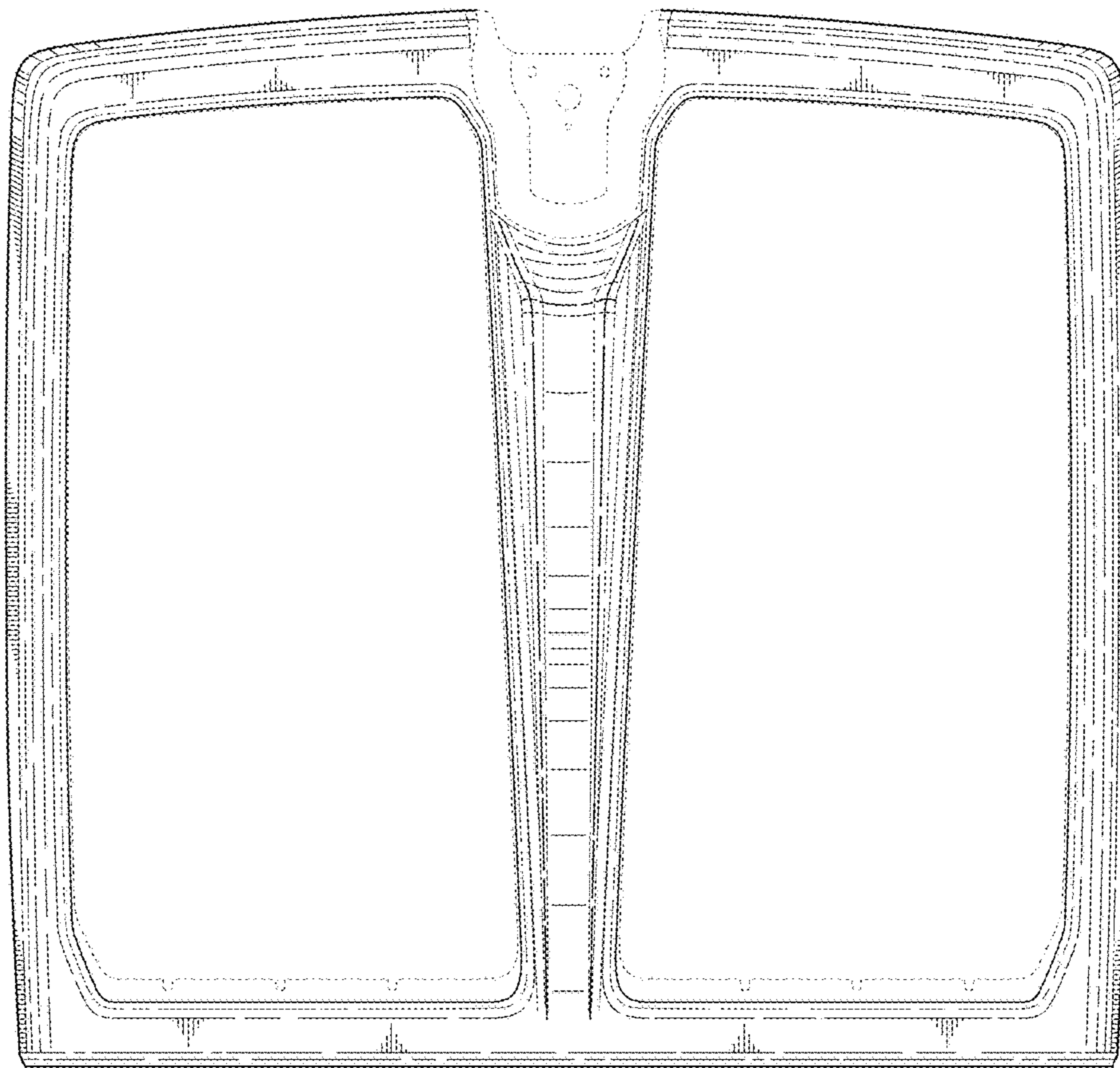

Fig. 2.

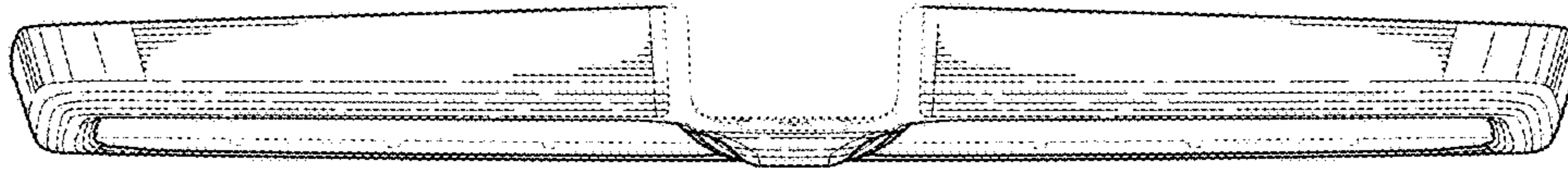

Fig. 3.



Fig. 4.

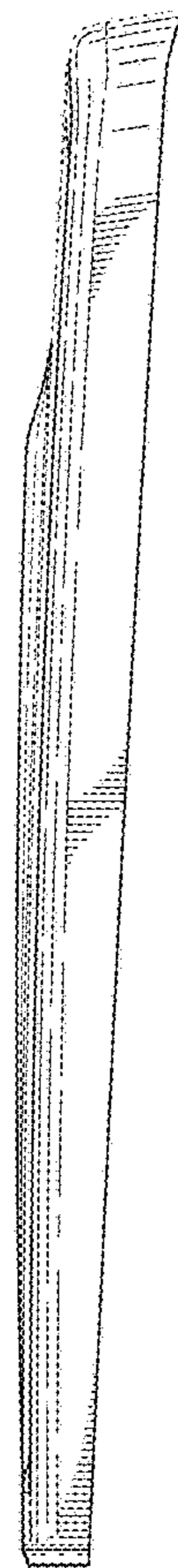

Fig. 5.