

US00D869156S

(12) **United States Design Patent** (10) **Patent No.:** **US D869,156 S**
Zeller (45) **Date of Patent:** **** Dec. 10, 2019**

(54) **HANDBAG WITH ARMOR PANEL EFFECT**

(71) Applicant: **Delvaux Createur SA**, Brussels (BE)

(72) Inventor: **Christina Zeller**, Brussels (BE)

(73) Assignee: **Delvaux Createur SA**, Brussels (BE)

(**) Term: **15 Years**

(21) Appl. No.: **29/662,013**

(22) Filed: **Aug. 31, 2018**

(30) **Foreign Application Priority Data**

Mar. 1, 2018 (EM) 004733749

(51) **LOC (12) Cl.** **03-01**

(52) **U.S. Cl.**
USPC **D3/243**

(58) **Field of Classification Search**
USPC D3/232–233, 240–243, 245–246
CPC A45C 1/024; A45C 3/06
See application file for complete search history.

(56) **References Cited**

U.S. PATENT DOCUMENTS

D524,053 S *	7/2006	Hillerich	D3/232
D631,653 S *	2/2011	Brown	D3/232
D730,643 S *	6/2015	Langer	D3/232
D768,379 S *	10/2016	Luo	D3/232
D778,602 S *	2/2017	Heyman	D3/243
D778,603 S *	2/2017	Heyman	D3/243
D778,604 S *	2/2017	Heyman	D3/243
D787,180 S *	5/2017	Maier	D3/243

OTHER PUBLICATIONS

“Delvaux Limited Edition Dark Night,” BagaholicBoy, Feb. 3, 2016. 7 pages.

“Delvaux’s Klimt-inspired handbags,” how to spend it, Nov. 15, 2016. 2 pages.

* cited by examiner

Primary Examiner — Holly H Baynham
(74) *Attorney, Agent, or Firm* — Weaver Austin Villeneuve & Sampson LLP

(57) **CLAIM**

What is claimed is a handbag with armor panel effect, as shown and described.

DESCRIPTION

FIG. 1 is a perspective view of a handbag with an armor panel effect.

FIG. 2 is a front view of the handbag with armor panel effect of FIG. 1.

FIG. 3 is a rear view of the handbag with armor panel effect of FIG. 1.

FIG. 4 is a side view of the handbag with armor panel effect of FIG. 1.

FIG. 5 is an opposing side view of the handbag with armor panel effect of FIG. 1.

FIG. 6 is a top view of the handbag with armor panel effect of FIG. 1; and,

FIG. 7 is a bottom view of the handbag with armor panel effect of FIG. 1.

Embodiments of a handbag with armor panel effect are depicted. In the embodiments of FIGS. 1-7, portions of handbag that are hatched with diagonal hatching patterns are translucent, allowing aspects of the handbag on the opposing surface to be seen through the handbag. Portions of the handbag that are visible through the translucent portions are depicted using lighter weight, grey lines (as compared with the heavier weight, black lines used to depict edges). Non-diagonal hatching is used to represent shading, and the dashed lines shown represent stitches.

For clarity, the black-and-white line drawing embodiments are not intended to convey color or material texture.

1 Claim, 5 Drawing Sheets





Figure 1

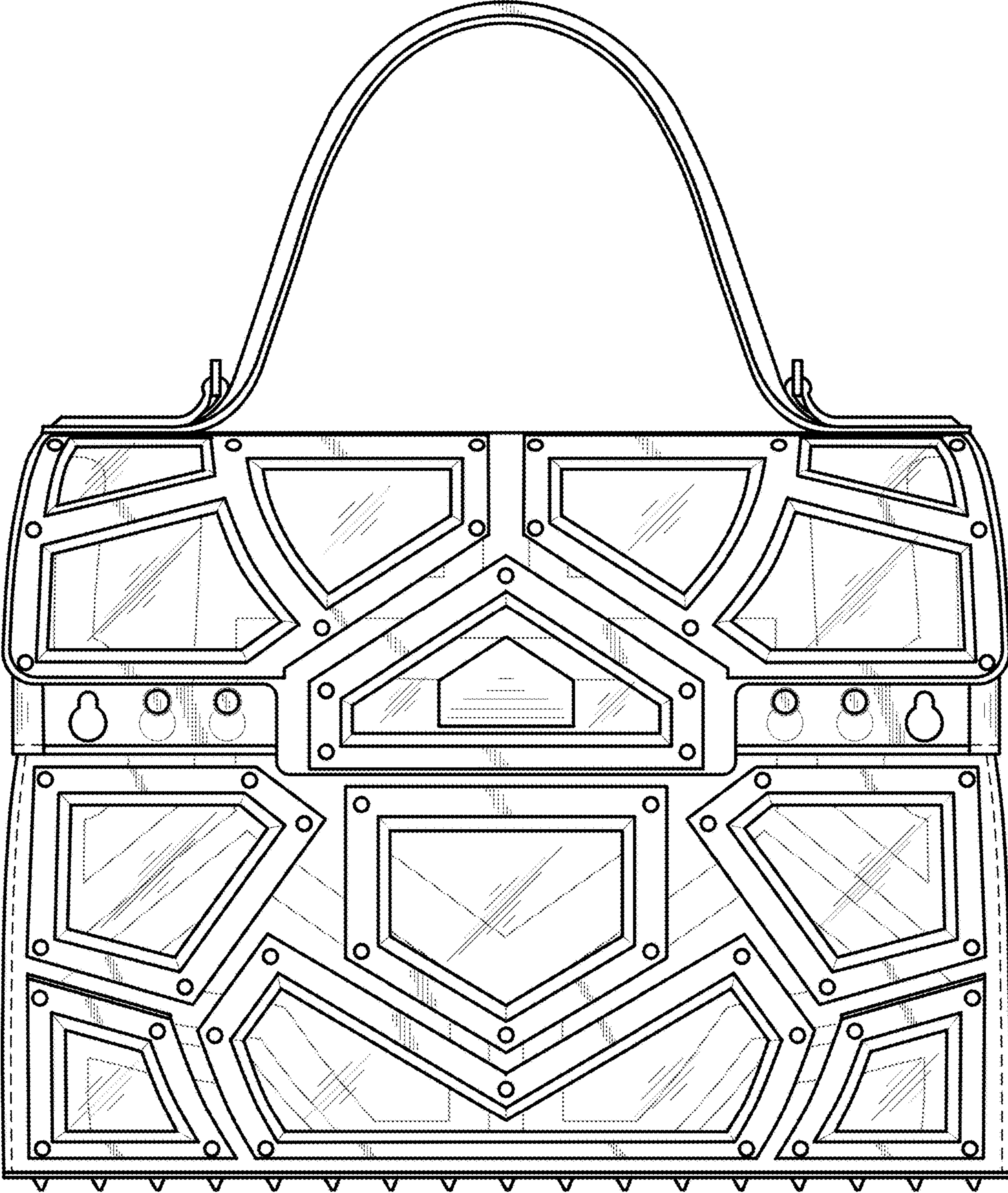

Figure 2



Figure 3

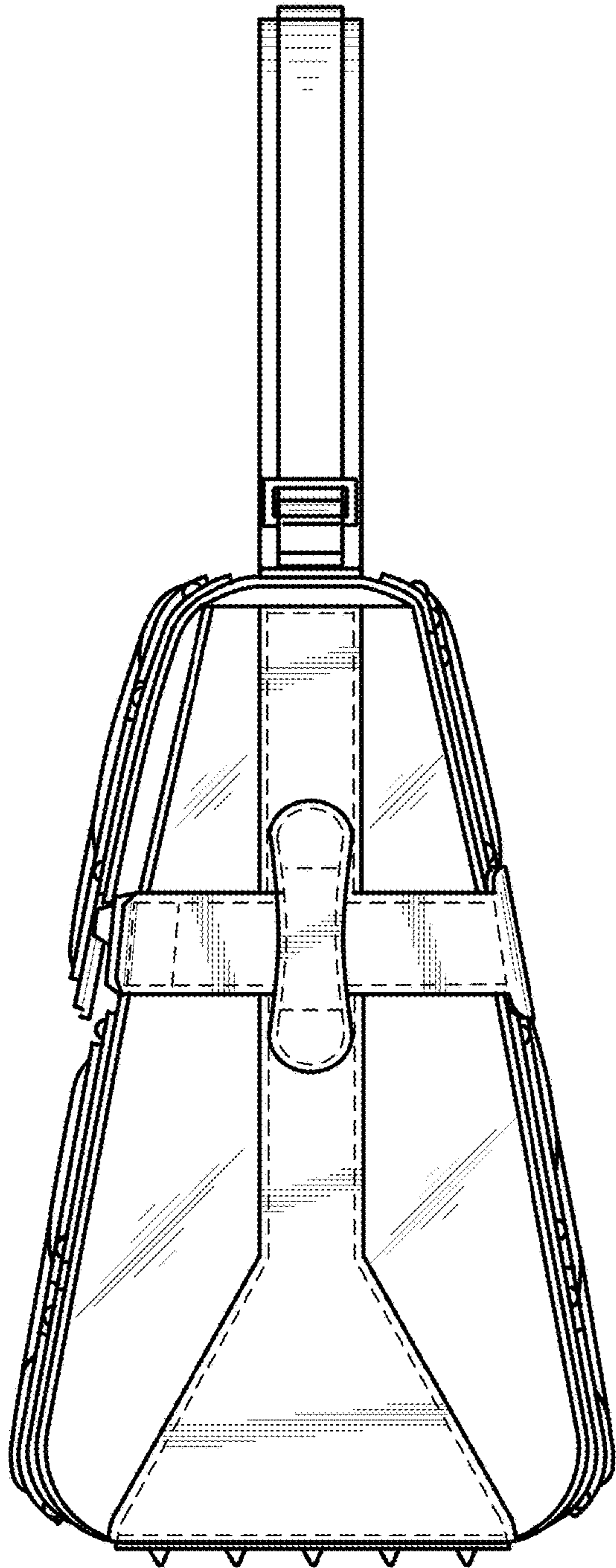

Figure 4

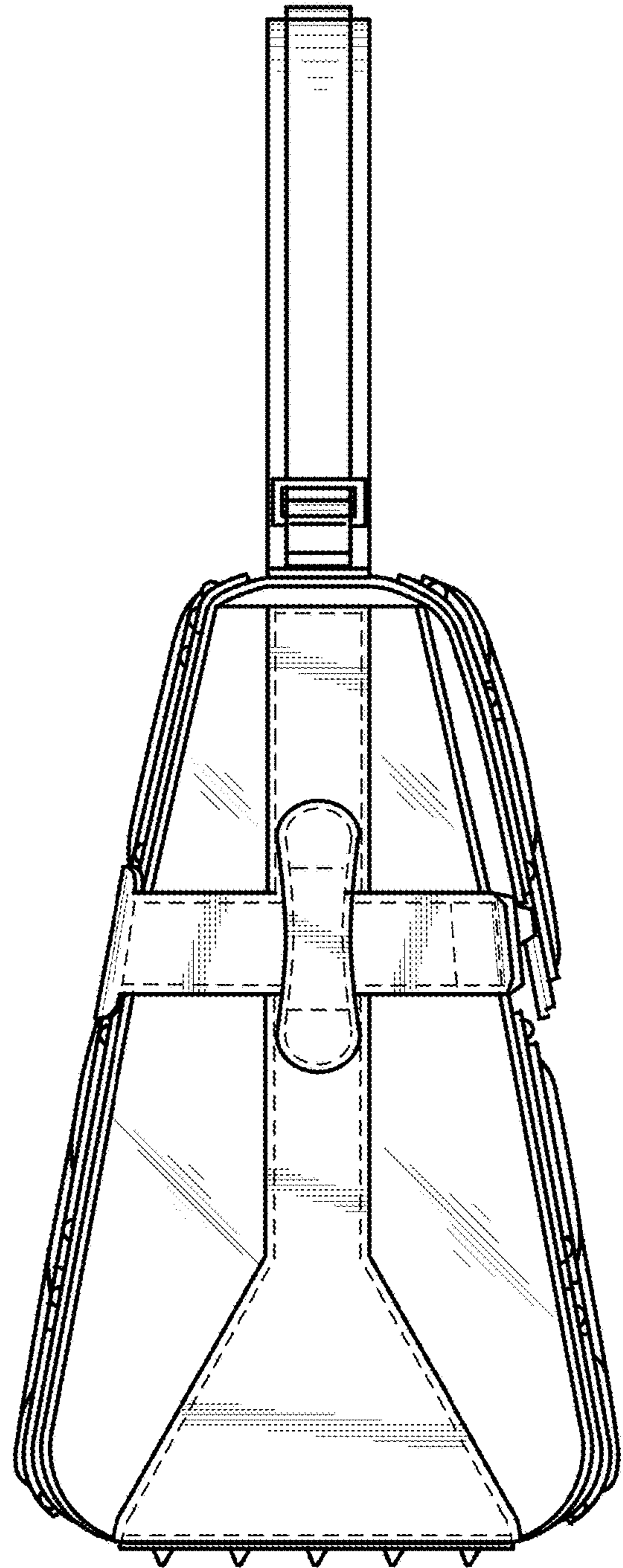

Figure 5

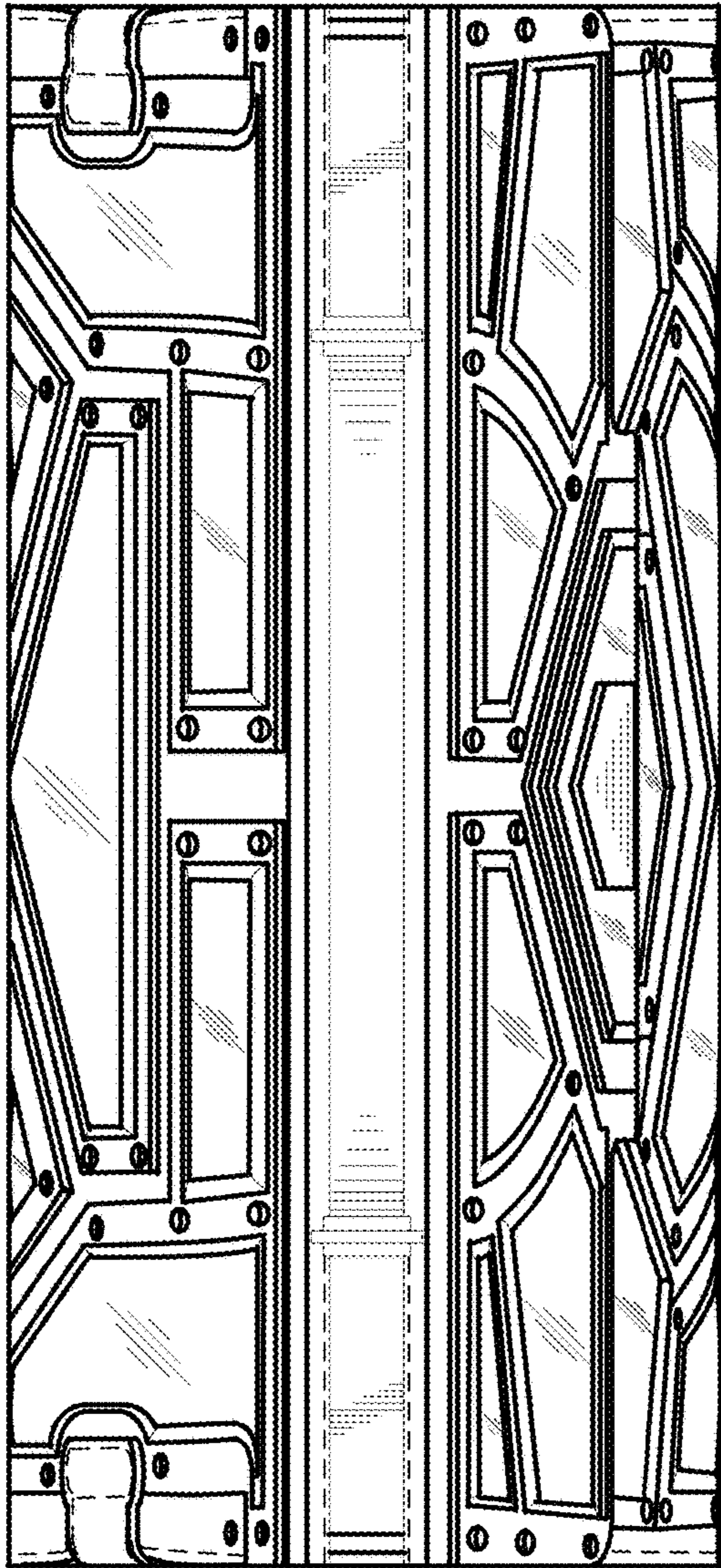

Figure 6

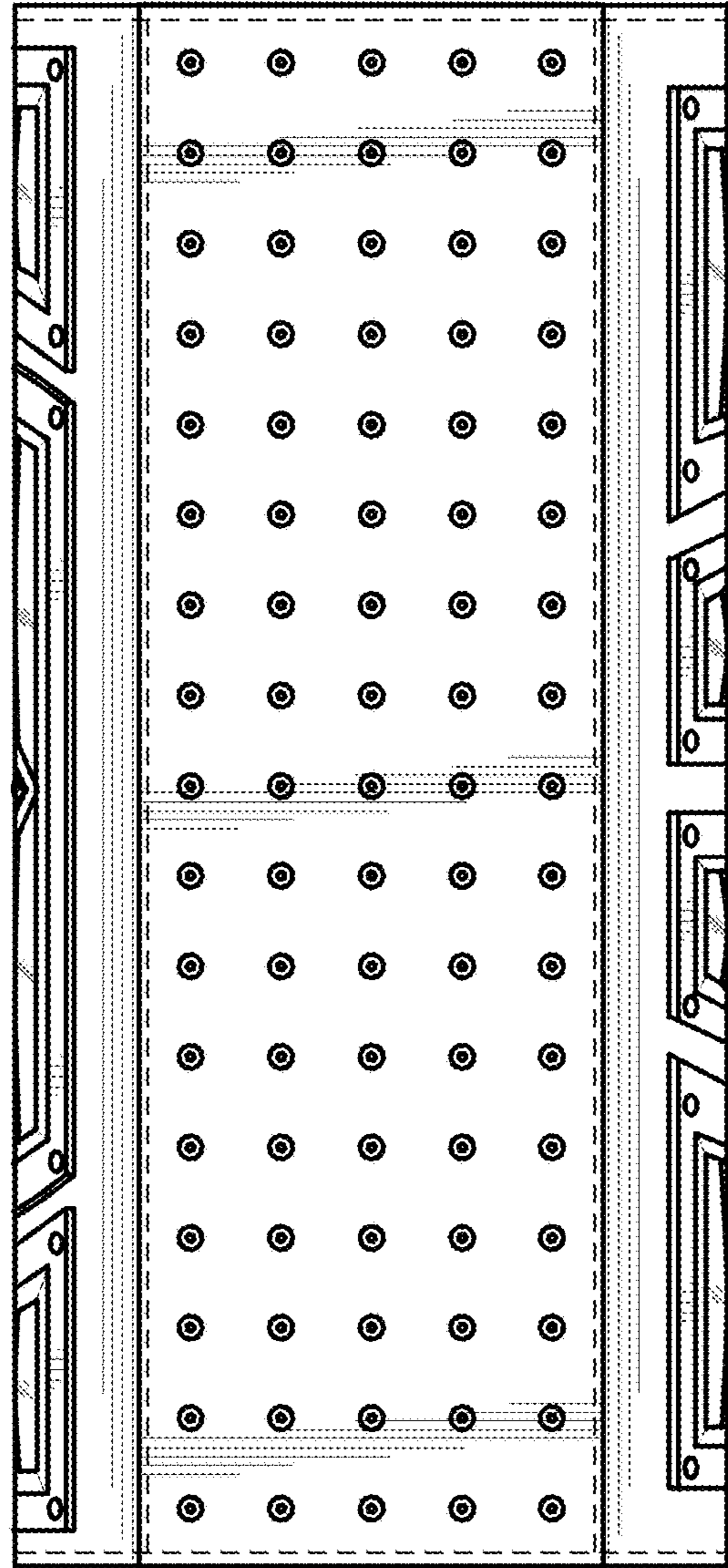

Figure 7