

US00D869029S

(12) **United States Design Patent**
Wang et al.

(10) **Patent No.:** **US D869,029 S**
(45) **Date of Patent:** **** Dec. 3, 2019**

(54) **AUTOMOBILE HEADLAMP**
(71) Applicant: **Chongqing Jinkang New Energy Automobile Co., Ltd.**, Chongqing (CN)
(72) Inventors: **Hongzhi Wang**, Chongqing (CN); **Bo Lun**, Chongqing (CN); **Wengang Yuan**, Chongqing (CN)
(**) Term: **15 Years**
(21) Appl. No.: **29/664,540**
(22) Filed: **Sep. 26, 2018**
(51) **LOC (12) Cl.** **26-06**
(52) **U.S. Cl.**
USPC **D26/28**
(58) **Field of Classification Search**
USPC D26/28-36, 139
CPC F21S 48/00; F21S 48/10; F21S 48/115;
F21S 48/225; F21S 48/1233; F21S 48/1266; F21S 48/1388; F21S 48/2268;
F21V 21/04; B60Q 9/13; B60Q 9/135;
B60Q 9/1375
See application file for complete search history.

D569,015 S * 5/2008 Tsukui D26/28
D573,734 S * 7/2008 Watanabe D26/28
D603,076 S * 10/2009 Hung D26/28

* cited by examiner

Primary Examiner — Marcus A Jackson
(74) *Attorney, Agent, or Firm* — Kilpatrick Townsend & Stockton, LLP

(57) **CLAIM**

The ornamental design of an automobile headlamp, as shown and described.

DESCRIPTION

FIG. 1 is a perspective view of an automobile headlamp, showing our new design;
FIG. 2 is a top plan view thereof;
FIG. 3 is a bottom plan view thereof;
FIG. 4 is a front elevation view thereof;
FIG. 5 is a rear elevation view thereof;
FIG. 6 is a left side elevation view thereof; and,
FIG. 7 is a right side elevation view thereof.
The broken lines immediately adjacent any shaded areas represent the bounds of the claimed design while all other broken lines are directed to environment and are for illustrative purposes only. The broken lines form no part of the claimed design.

(56) **References Cited**
U.S. PATENT DOCUMENTS
D552,274 S * 10/2007 Tanaka D26/28
D568,501 S * 5/2008 Nakazawa D26/28

1 Claim, 4 Drawing Sheets

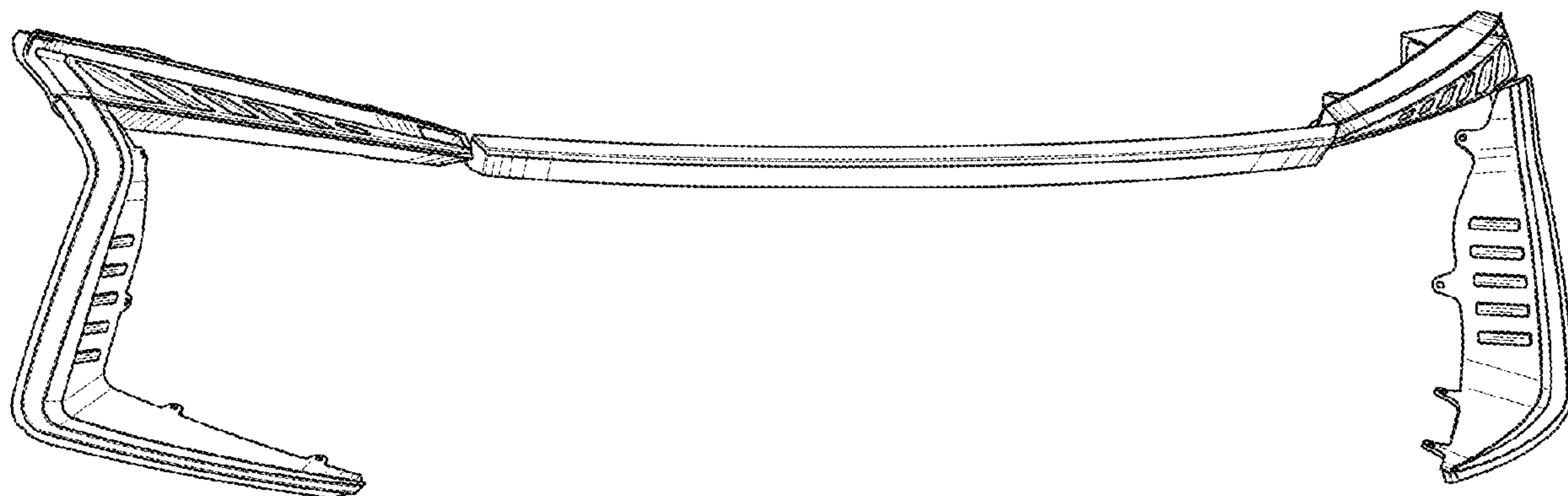

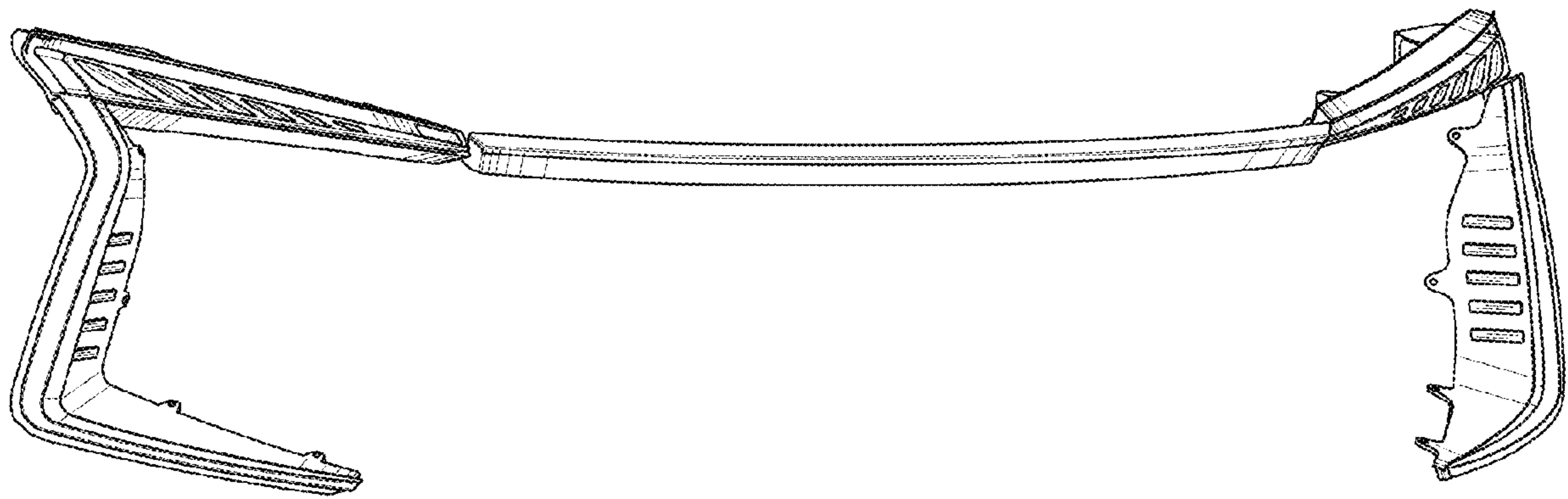

FIG. 1

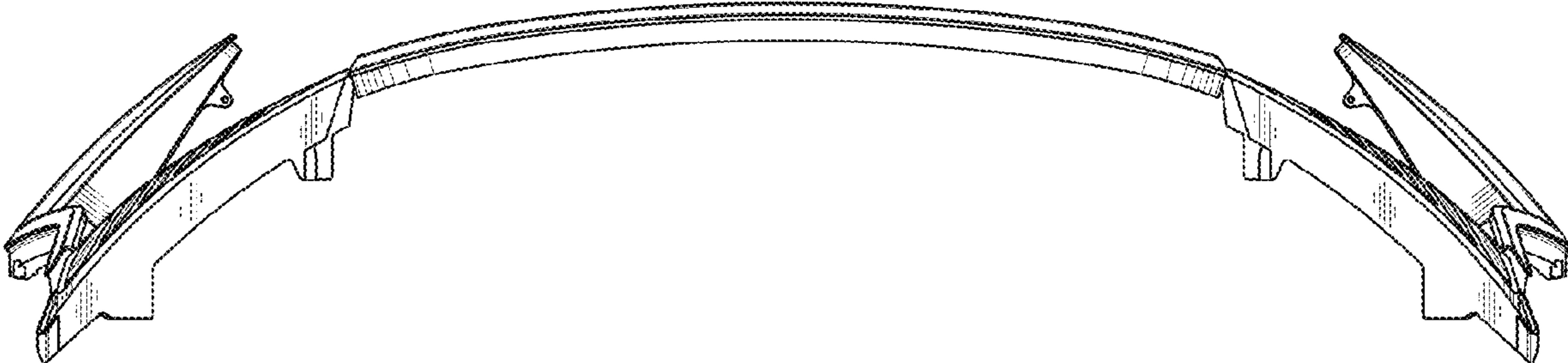

FIG. 2

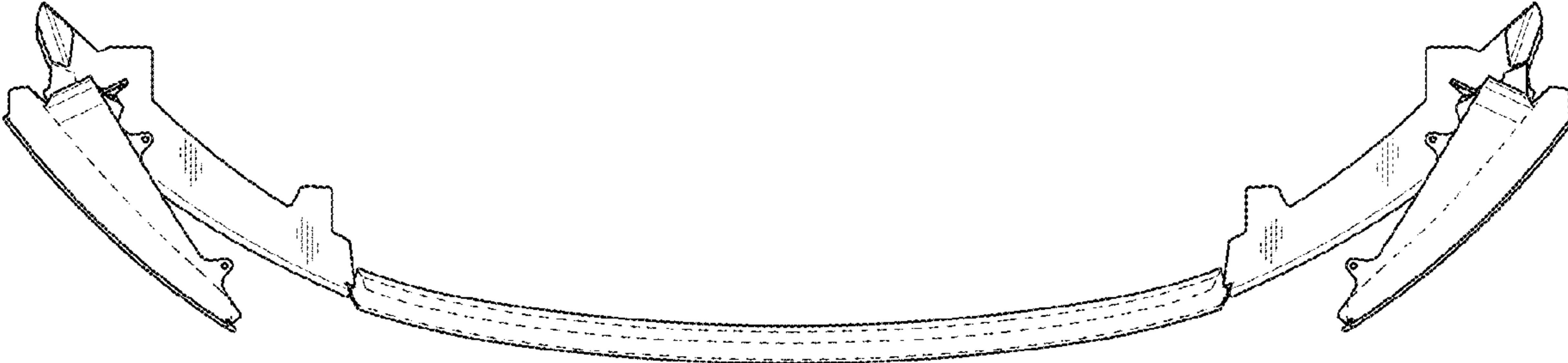

FIG. 3

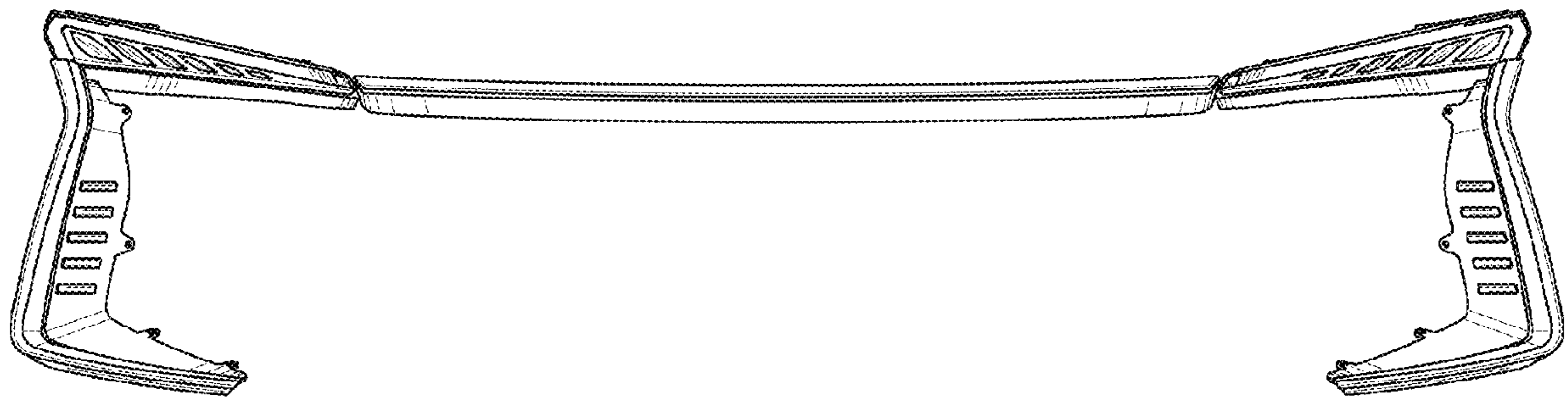

FIG. 4

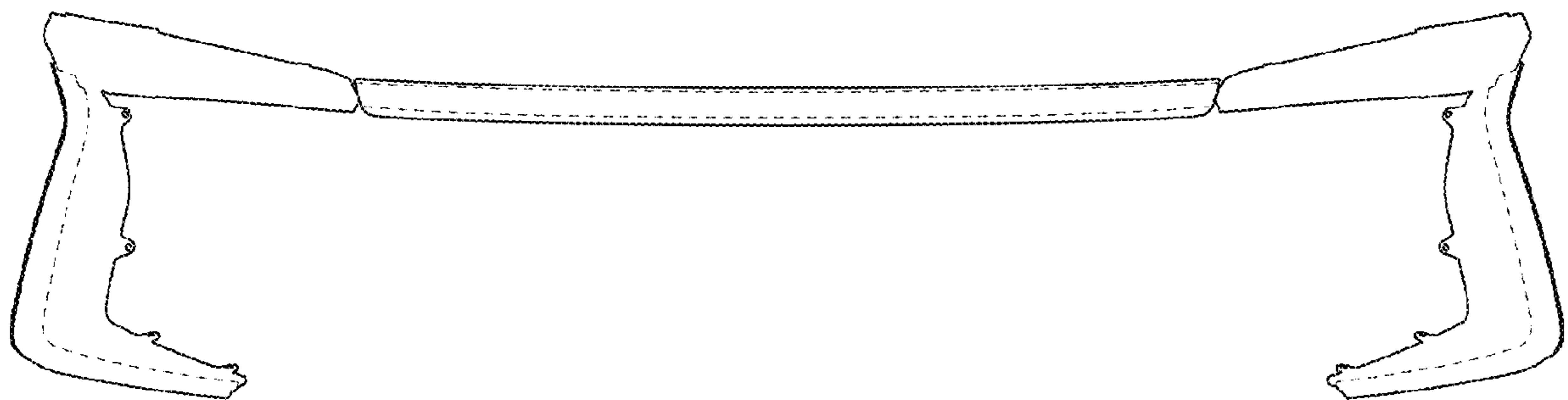

FIG. 5

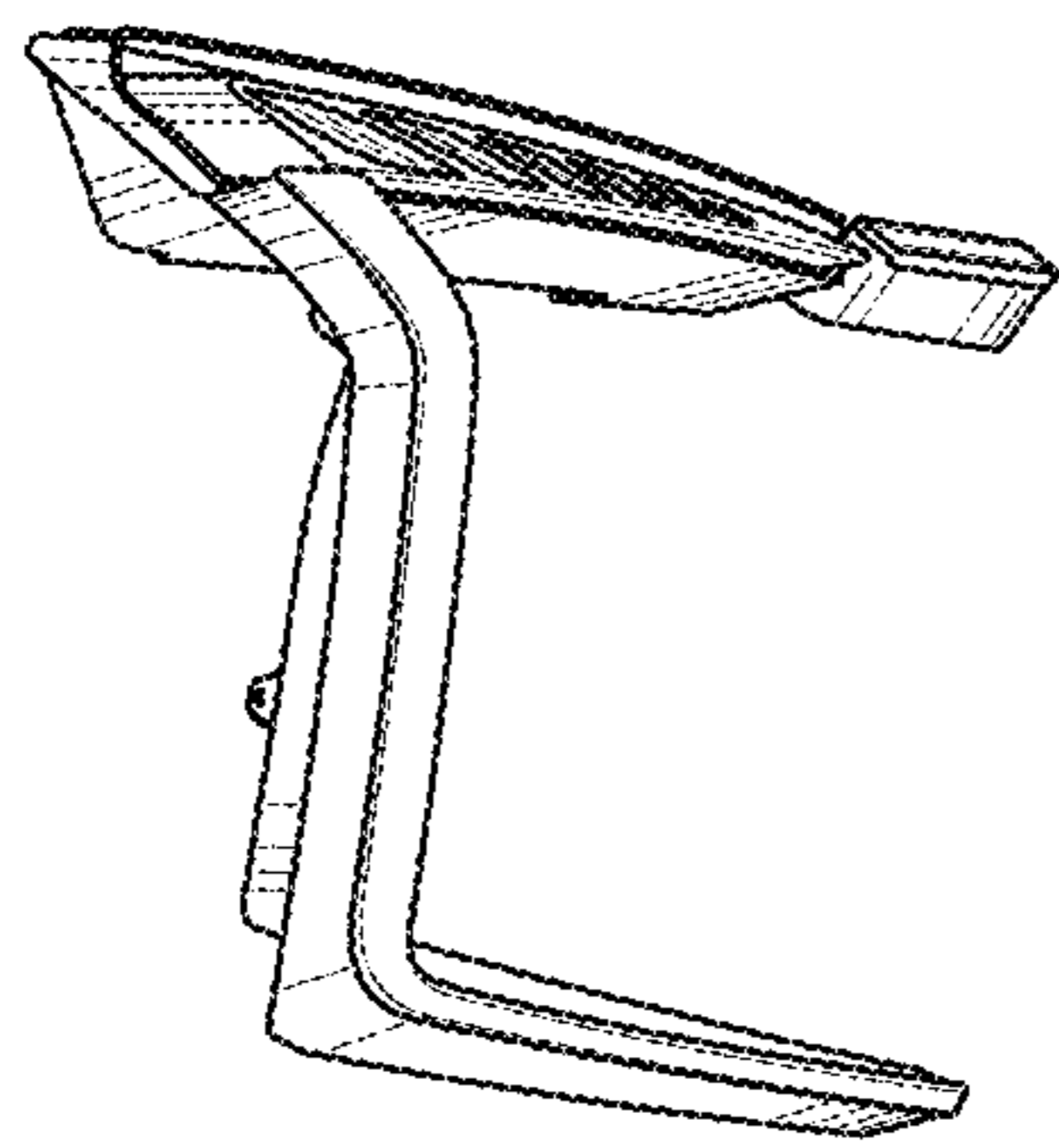

FIG. 6

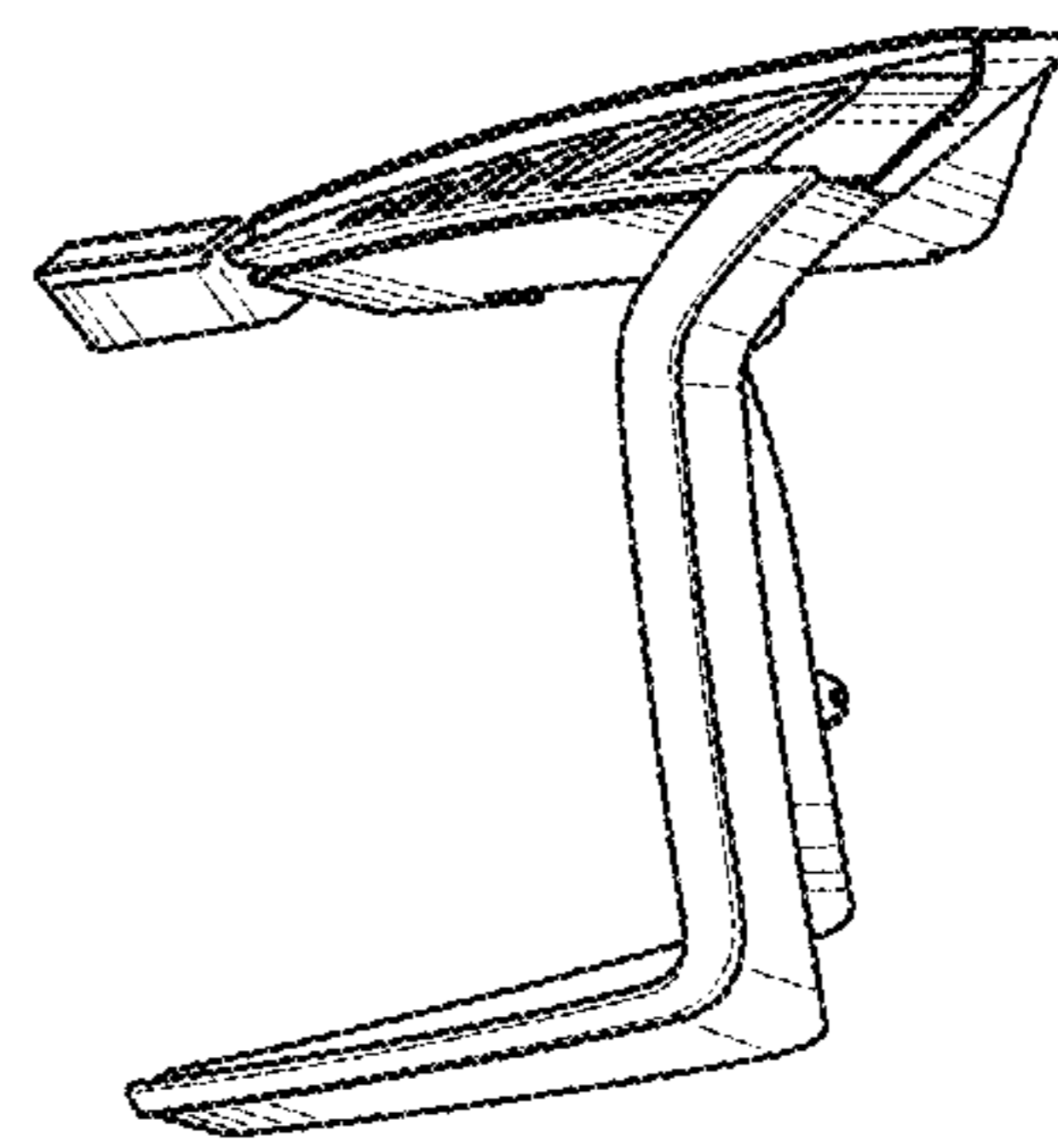

FIG. 7