



US00D868652S

(12) **United States Design Patent**
Gifford

(10) **Patent No.:** **US D868,652 S**

(45) **Date of Patent:** **** Dec. 3, 2019**

- (54) **VEHICLE HOOD INSERT**
- (71) Applicant: **GM GLOBAL TECHNOLOGY OPERATIONS LLC**, Detroit, MI (US)
- (72) Inventor: **Daniel C. Gifford**, Sterling Heights, MI (US)
- (73) Assignee: **GM GLOBAL TECHNOLOGY OPERATIONS LLC**, Detroit, MI (US)
- (**) Term: **15 Years**

- D605,082 S 12/2009 Munson
- D605,083 S 12/2009 Manoogian, II et al.
- D605,977 S 12/2009 Zipfel et al.
- D605,978 S 12/2009 Wolff et al.
- D608,249 S 1/2010 Peters
- D608,690 S 1/2010 Folden et al.
- D608,691 S 1/2010 Zak, Jr. et al.
- D609,608 S 2/2010 Boniface et al.
- D611,387 S 3/2010 Thompson et al.
- D611,879 S 3/2010 Kim et al.
- D612,297 S 3/2010 Peters et al.
- D613,645 S 4/2010 Song et al.
- D615,458 S 5/2010 Thompson et al.
- D618,595 S 6/2010 Ware et al.

(Continued)

- (21) Appl. No.: **29/649,618**
- (22) Filed: **May 31, 2018**
- (51) **LOC (12) Cl.** **12-08**
- (52) **U.S. Cl.**
USPC **D12/173**
- (58) **Field of Classification Search**
USPC D12/86, 90–92, 163, 169, 171, 173, 181,
D12/184, 196, 216, 388
CPC ... B60R 19/52; B60R 21/34; B60R 2021/343;
B60K 11/08; B62D 25/08; B62D 25/105;
B62D 25/12; B62B 9/16
See application file for complete search history.

(56) **References Cited**

U.S. PATENT DOCUMENTS

- 4,889,382 A * 12/1989 Burst B60K 11/08
296/180.5
- D511,730 S * 11/2005 Rowland D12/190
- D512,947 S * 12/2005 Buerlein D12/196
- D523,790 S * 6/2006 Polka D12/163
- D570,742 S 6/2008 Takagi et al.
- D592,105 S 5/2009 Dean et al.
- D597,447 S 8/2009 Folden
- D600,595 S 9/2009 Nakamura et al.
- D601,925 S 10/2009 O'Donnell
- D603,755 S 11/2009 Peters
- D604,203 S 11/2009 O'Donnell

OTHER PUBLICATIONS

Padeanu, Adrian. "2017 Chevy Silverado 2500 HD gets ram-air head scoop." Motor1, published Jun. 3, 2016 (Retrieved from the Internet Sep. 3, 2019). Internet URL: <<https://www.motor1.com/news/63333/2017-chevy-silverado-2500-hd-gets-ram-air-hood-scoop/>> (Year: 2016).*

(Continued)

Primary Examiner — Jack Reickel
Assistant Examiner — Rachel A Voorhies

(57) **CLAIM**

The ornamental design for a vehicle hood insert, as shown and described.

DESCRIPTION

FIG. 1 is a perspective view of the vehicle hood insert; FIG. 2 is a front view thereof; FIG. 3 is a top view thereof; and, FIG. 4 is a left side view thereof (where the right side view is a mirror image thereof). The broken lines in the drawings illustrate portions of the vehicle hood insert that form no part of the claimed design.

1 Claim, 2 Drawing Sheets

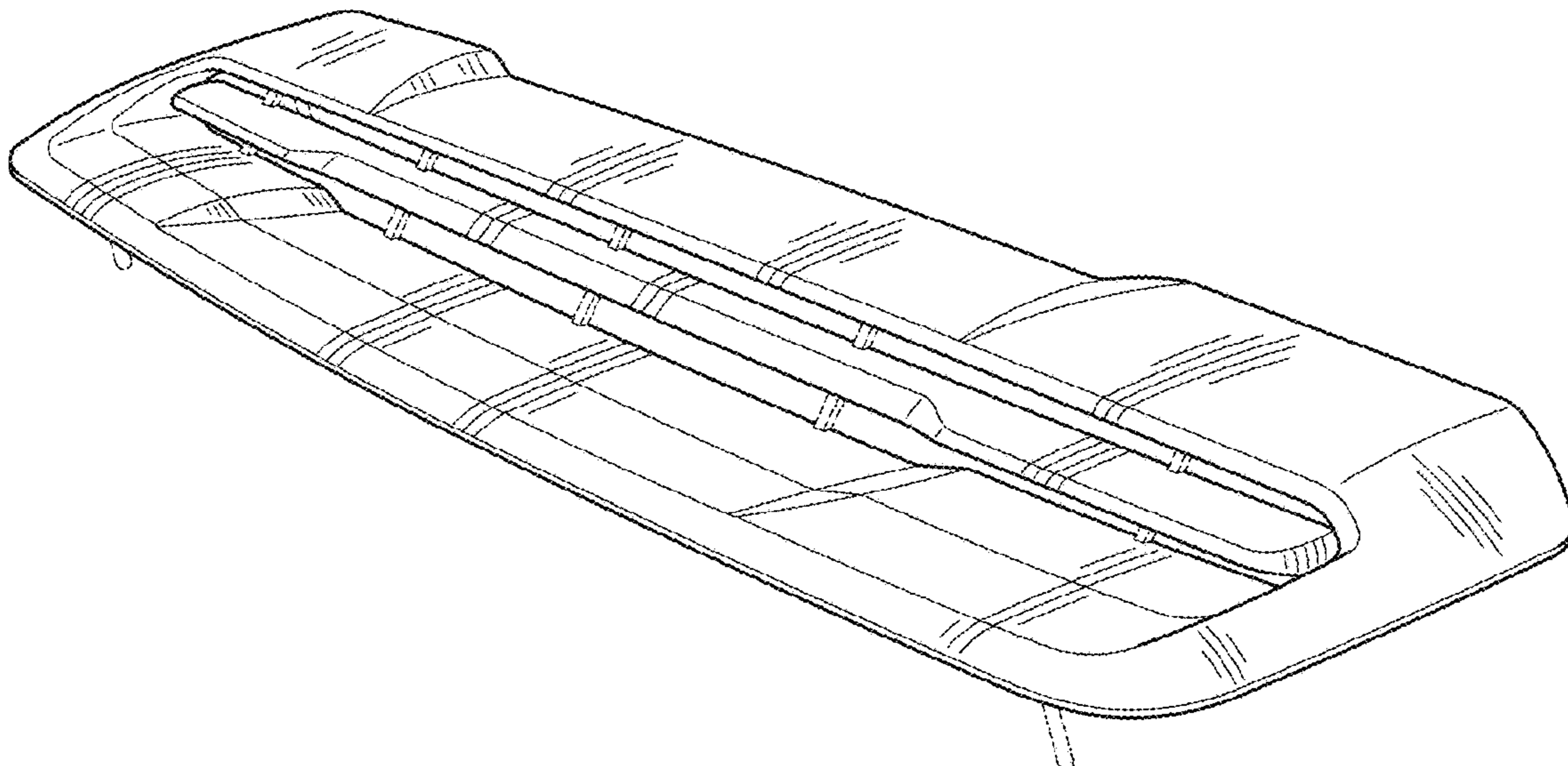

(56)

References Cited

U.S. PATENT DOCUMENTS

D623,090 S	9/2010	Cox et al.	D746,730 S	1/2016	Kim et al.
D627,262 S	11/2010	Ikeda et al.	D747,514 S	1/2016	McMahan et al.
D635,488 S	4/2011	Phipps	D747,515 S	1/2016	McMahan et al.
D644,147 S	8/2011	Suh et al.	D747,819 S	1/2016	Thole et al.
D644,567 S	9/2011	Kozub	D749,021 S	2/2016	Boniface et al.
D657,718 S	4/2012	Zipfel et al.	D749,026 S	2/2016	Smith et al.
D659,052 S	5/2012	Ware et al.	D749,027 S	2/2016	McMahan et al.
D659,053 S	5/2012	Ware et al.	D749,246 S	2/2016	Thole et al.
D668,182 S	10/2012	Barba Franco et al.	D749,249 S	2/2016	Thole et al.
D668,183 S	10/2012	Smart	D749,250 S	2/2016	Thole et al.
D669,407 S	* 10/2012	Varga D12/196	D749,985 S	2/2016	Kozub et al.
D678,152 S	* 3/2013	Behmer D12/173	D749,997 S	2/2016	McMahan et al.
D678,820 S	3/2013	Son et al.	D750,001 S	2/2016	Thole et al.
D678,821 S	3/2013	Ikeda et al.	D753,032 S	4/2016	Smith et al.
D680,909 S	4/2013	Munson et al.	D753,033 S	4/2016	Thole et al.
D680,910 S	4/2013	David	D753,034 S	4/2016	Thole et al.
D684,899 S	6/2013	Baker	D753,035 S	4/2016	Boniface et al.
D686,536 S	7/2013	McCabe et al.	D753,559 S	4/2016	McMahan et al.
D692,798 S	11/2013	Thurber	D753,560 S	4/2016	McMahan et al.
D692,799 S	11/2013	Smith et al.	D753,567 S	4/2016	Boniface et al.
D696,157 S	12/2013	Loeb	D754,571 S	4/2016	Boniface et al.
D696,165 S	* 12/2013	Campbell D12/163	D754,572 S	4/2016	McMahan et al.
D696,173 S	* 12/2013	Hatter D12/196	D755,088 S	5/2016	McMahan et al.
D699,629 S	2/2014	Ikeda et al.	D756,869 S	5/2016	McMahan et al.
D700,871 S	3/2014	O'Donnell et al.	D758,257 S	* 6/2016	Platto D12/163
D703,103 S	4/2014	Lee	D758,271 S	6/2016	McMahan et al.
D703,597 S	* 4/2014	Larson D12/196	D764,975 S	8/2016	Aengenheyster
D704,103 S	5/2014	Mack et al.	D764,976 S	8/2016	Aengenheyster
D705,132 S	5/2014	Ware et al.	D767,449 S	9/2016	Pevovar et al.
D705,699 S	5/2014	Ware et al.	D767,450 S	9/2016	Lee et al.
D710,284 S	* 8/2014	Larson D12/196	D767,451 S	9/2016	Kozub et al.
D713,298 S	9/2014	Dyson	D767,454 S	9/2016	McMahan et al.
D713,764 S	9/2014	Ferlazzo et al.	D767,458 S	9/2016	Kim
D716,696 S	11/2014	Thole et al.	D767,459 S	9/2016	Kim
D716,706 S	11/2014	Thole et al.	D767,460 S	9/2016	Kozub et al.
D716,709 S	11/2014	Thole et al.	D767,461 S	9/2016	Kozub et al.
D717,696 S	11/2014	Thole et al.	D771,528 S	11/2016	Smith et al.
D718,189 S	11/2014	Krieg et al.	D771,529 S	11/2016	Thole et al.
D718,683 S	12/2014	Thole et al.	D771,532 S	11/2016	Kapitonov
D722,282 S	2/2015	Loeb	D771,533 S	11/2016	Kapitonov
D722,533 S	2/2015	Thole et al.	D772,766 S	11/2016	Kozub et al.
D722,534 S	2/2015	Munson et al.	D772,767 S	11/2016	Kim
D724,510 S	3/2015	McMahan et al.	D773,084 S	11/2016	Kapitonov
D725,001 S	3/2015	McMahan et al.	D773,086 S	11/2016	McCabe et al.
D726,591 S	4/2015	Jacob	9,499,209 B1 *	11/2016	Frank B60R 13/08
D730,776 S	6/2015	Smart	D774,226 S	12/2016	McCabe et al.
D730,783 S	6/2015	Henriques et al.	D775,003 S	12/2016	Pevovar et al.
D732,427 S	6/2015	Loeb	D775,007 S	12/2016	Thole et al.
D732,429 S	6/2015	Loeb	D775,010 S	12/2016	Kim et al.
D732,430 S	6/2015	Loeb	D775,049 S	12/2016	Scheer et al.
D732,431 S	6/2015	Loeb	D775,549 S	1/2017	Karras
D732,432 S	6/2015	Aengenheyster	D775,554 S	1/2017	Kapitonov
D732,433 S	6/2015	Aengenheyster	D776,020 S	1/2017	Kapitonov
D732,435 S	6/2015	Mackay	D776,581 S	1/2017	Pevovar et al.
D733,002 S	6/2015	Loeb	D776,583 S	1/2017	Scheer et al.
D735,611 S	8/2015	Aengenheyster	D776,841 S	1/2017	Kozub et al.
D735,627 S	8/2015	Smith	D776,843 S	1/2017	McCabe et al.
D736,451 S	8/2015	Smith	D776,846 S	1/2017	Willett et al.
D739,306 S	9/2015	McMahan et al.	D777,359 S	1/2017	Kozub et al.
D739,317 S	9/2015	McMahan et al.	D777,360 S	1/2017	Kozub et al.
D741,223 S	10/2015	Kim et al.	D777,361 S	1/2017	Kozub et al.
D743,309 S	11/2015	Thole et al.	D777,604 S	1/2017	McNerney
D743,313 S	11/2015	Smith et al.	D777,605 S	1/2017	Ferlazzo et al.
D743,314 S	11/2015	Thole et al.	D777,620 S	1/2017	Pevovar et al.
D743,857 S	11/2015	McMahan et al.	D777,621 S	1/2017	Kim
D744,158 S	11/2015	Willett et al.	D777,622 S	1/2017	Kozub et al.
D745,086 S	12/2015	Finos et al.	D777,628 S	1/2017	Kozub et al.
D745,719 S	12/2015	Boniface et al.	D777,955 S	1/2017	Willett et al.
D745,725 S	12/2015	McMahan et al.	D778,212 S	2/2017	Kozub et al.
D745,726 S	12/2015	McMahan et al.	D778,215 S	2/2017	Kozub et al.
D745,837 S	12/2015	Smith et al.	D780,064 S	2/2017	Smith et al.
D746,726 S	1/2016	Smith et al.	D780,067 S	2/2017	Zipfel et al.
D746,727 S	1/2016	Smith et al.	D780,068 S	2/2017	Whitla et al.
D746,728 S	1/2016	Smith et al.	D780,077 S	2/2017	Kim et al.
D746,729 S	1/2016	Boniface et al.	D780,081 S	2/2017	Lee
			D780,084 S	2/2017	Scheer et al.
			D780,631 S	3/2017	Kozub et al.
			D780,644 S	3/2017	Kim et al.
			D781,184 S	3/2017	Thole et al.

(56)

References Cited

U.S. PATENT DOCUMENTS

D781,192 S	3/2017	Kozub et al.	D797,971 S	9/2017	Mainville
D782,379 S	3/2017	Wassell	D797,972 S	9/2017	Whitla et al.
D783,482 S	4/2017	Smith et al.	D798,204 S	9/2017	Mainville
D784,213 S	4/2017	Karras	D799,384 S	10/2017	Kozub et al.
D784,223 S	4/2017	Lee	D799,385 S	10/2017	Kozub et al.
D784,226 S	4/2017	Cheng	D799,386 S	10/2017	Kozub et al.
D784,579 S	4/2017	Cheng et al.	D799,728 S	10/2017	Whitla et al.
D784,877 S	4/2017	Lee	D801,236 S	10/2017	Kozub et al.
D784,886 S	4/2017	Smith et al.	D801,577 S	10/2017	Ruiz
D785,521 S	5/2017	Smith et al.	D801,882 S	11/2017	Kozub et al.
D786,149 S	5/2017	Pevovar et al.	D802,205 S	11/2017	Ruiz
D786,743 S	5/2017	Smith et al.	D802,478 S	11/2017	Perkins
D786,750 S	5/2017	Lee	D802,491 S	11/2017	Mainville
D787,446 S	5/2017	Cockerill	D802,496 S	11/2017	Mainville
D787,984 S	5/2017	Fang	D802,502 S	11/2017	McMahan
D787,988 S	5/2017	Lee	D803,727 S	11/2017	Noone et al.
D787,989 S	5/2017	Kozub et al.	D803,731 S	11/2017	Zipfel
D787,990 S	5/2017	Kozub et al.	D804,370 S	12/2017	Kozub et al.
D787,992 S	5/2017	Lee	D804,371 S	12/2017	Whitla et al.
D787,993 S	5/2017	McCabe et al.	D804,372 S	12/2017	Kozub
D788,001 S	5/2017	Lee	D804,378 S	12/2017	Perkins
D788,641 S	6/2017	Arnold	D804,379 S	12/2017	McMahan
D788,644 S	6/2017	Mueller	D805,006 S	12/2017	Nakamura
D788,645 S	6/2017	Mueller	D805,013 S	12/2017	Whitla
D789,250 S	6/2017	Arnold	D805,014 S	12/2017	Zipfel
D789,260 S	6/2017	Smith	D805,441 S	12/2017	Karras
D789,575 S	6/2017	Willett	D805,964 S	12/2017	Whitla
D789,841 S	6/2017	Lee	D805,965 S	12/2017	Davis
D789,849 S	6/2017	Lee	D805,966 S	12/2017	Perkins
D791,018 S	7/2017	Mylenek	D805,975 S	12/2017	Dharmawan D12/181
D791,644 S	7/2017	Fang	D805,985 S	12/2017	Nakamura
D792,290 S	7/2017	Smith et al.	D807,232 S	1/2018	Bailie
D792,293 S	7/2017	McCabe et al.	D807,239 S	1/2018	Perkins
D792,294 S	7/2017	McCabe et al.	D807,240 S	1/2018	Perkins
D792,295 S	7/2017	McCabe et al.	D807,241 S	1/2018	Perkins
D792,815 S	7/2017	Kozub	D809,442 S	2/2018	Zipfel et al.
D792,816 S	7/2017	Kozub	D811,269 S	2/2018	Thompson et al.
D793,290 S	8/2017	Kozub	D811,942 S	3/2018	Jacob
D793,292 S	8/2017	Lee	D811,957 S	3/2018	Whitla et al.
D793,293 S	8/2017	Lee et al.	D811,958 S	3/2018	Zipfel et al.
D793,294 S	8/2017	Lee	D811,959 S	3/2018	Perkins
D793,295 S	8/2017	McCabe et al.	D811,960 S	3/2018	Nakamura
D793,296 S	8/2017	Smith et al.	D811,961 S	3/2018	Sullivan
D793,297 S	8/2017	Smith et al.	D811,962 S	3/2018	Sullivan
D793,299 S	8/2017	Kreig et al.	D811,963 S	3/2018	Sullivan
D793,300 S	8/2017	Kreig et al.	D811,964 S	3/2018	Perkins
D793,301 S	8/2017	Kozub	D811,965 S	3/2018	Moffett et al.
D793,302 S	8/2017	Kozub	D812,525 S	3/2018	Lee
D793,311 S	8/2017	Whitla et al.	D812,526 S	3/2018	Zipfel et al.
D793,590 S	8/2017	Kozub et al.	D812,527 S	3/2018	Perkins
D793,591 S	8/2017	Kozub et al.	D812,528 S	3/2018	Nakamura
D793,917 S	8/2017	Kozub	D813,098 S	3/2018	Thompson et al.
D793,918 S	8/2017	Kozub	D813,109 S	3/2018	Zipfel et al.
D794,229 S	8/2017	Barry	D813,110 S	3/2018	Whitla et al.
D794,230 S	8/2017	Kozub	D813,111 S	3/2018	Sullivan
D795,747 S	8/2017	Bailie	D813,116 S	3/2018	Park
D795,757 S	8/2017	Pevovar et al.	D813,117 S	3/2018	Sullivan
D795,758 S	8/2017	Karras	D813,121 S	3/2018	Swanseger
D795,759 S	8/2017	Kozub et al.	D813,730 S	3/2018	Zipfel et al.
D795,760 S	8/2017	Kozub et al.	D813,731 S	3/2018	McMahan
D795,762 S	8/2017	Lee	D813,732 S	3/2018	Whitla et al.
D795,763 S	8/2017	Kozub	D813,733 S	3/2018	Lee
D796,088 S	8/2017	McCabe et al.	D813,734 S	3/2018	Nakamura
D796,093 S	8/2017	Mainville	D813,740 S	3/2018	Park
D796,390 S	9/2017	Pevovar et al.	D813,741 S	3/2018	Perkins
D797,537 S	9/2017	Cooper et al.	D813,742 S	3/2018	McMahan et al.
D797,603 S	9/2017	Noone et al.	D813,743 S	3/2018	Lee
D797,614 S	9/2017	Lee	D813,744 S	3/2018	Whitla et al.
D797,616 S	9/2017	Lee	D813,748 S	3/2018	Kim
D797,624 S	9/2017	Nakamura	D813,753 S	3/2018	Loeb
D797,625 S	9/2017	Perkins	D813,754 S	3/2018	Loeb
D797,631 S	9/2017	Pevovar et al.	D813,755 S	3/2018	Loeb
D797,632 S	9/2017	Zipfel et al.	D813,756 S	3/2018	Loeb
D797,967 S	9/2017	Barry	D813,757 S	3/2018	Kozub
D797,970 S	9/2017	Mainville	D813,758 S	3/2018	Gonzales
			D813,759 S	3/2018	Perkins
			D814,369 S	4/2018	Loeb
			D814,982 S	4/2018	Whitla et al.
			D814,983 S	4/2018	Whitla et al.

(56)

References Cited

U.S. PATENT DOCUMENTS

D815,570 S 4/2018 McMahan et al.
 D815,572 S 4/2018 Perkins
 D815,573 S 4/2018 Whitla et al.
 D815,574 S 4/2018 Mainville
 D815,993 S 4/2018 Kozub et al.
 D815,994 S 4/2018 Nakamura
 D816,003 S 4/2018 Perkins
 D820,176 S * 6/2018 Hamburger D12/173
 D830,258 S * 10/2018 Moffett D12/181
 D840,889 S * 2/2019 Torres D12/196
 D850,339 S * 6/2019 Lu D12/181
 D854,987 S * 7/2019 Grand D12/181
 2006/0201727 A1 * 9/2006 Chan B62D 25/105
 180/69.25
 2016/0237961 A1 * 8/2016 Callaway, III ... F02M 35/10157
 2018/0170172 A1 * 6/2018 Hanna B60K 13/02
 2018/0297650 A1 * 10/2018 Titus B62D 37/02

OTHER PUBLICATIONS

Collins, Andrew P. "The Chevy Silverado's New Hood Scoop looks Hungry." Jalopnik, published Jun. 3, 2016 (Retrieved from the Internet Sep. 3, 2019). Internet URL: <<https://jalopnik.com/the-chevy-silverados-new-hood-scoop-looks-hungry-1780405828>> (Year: 2016).*

Collins, Andrew P. "Here's How GMC's Huge New Hood Scoop Works Without Sucking in Water." Jalopnik, published Feb. 17, 2017 (Retrieved from the Internet Sep. 3, 2019). Internet URL: <<https://jalopnik.com/heres-how-gmcs-huge-new-hood-scoop-works-without-suckin-1792461481>> (Year: 2017).*

* cited by examiner

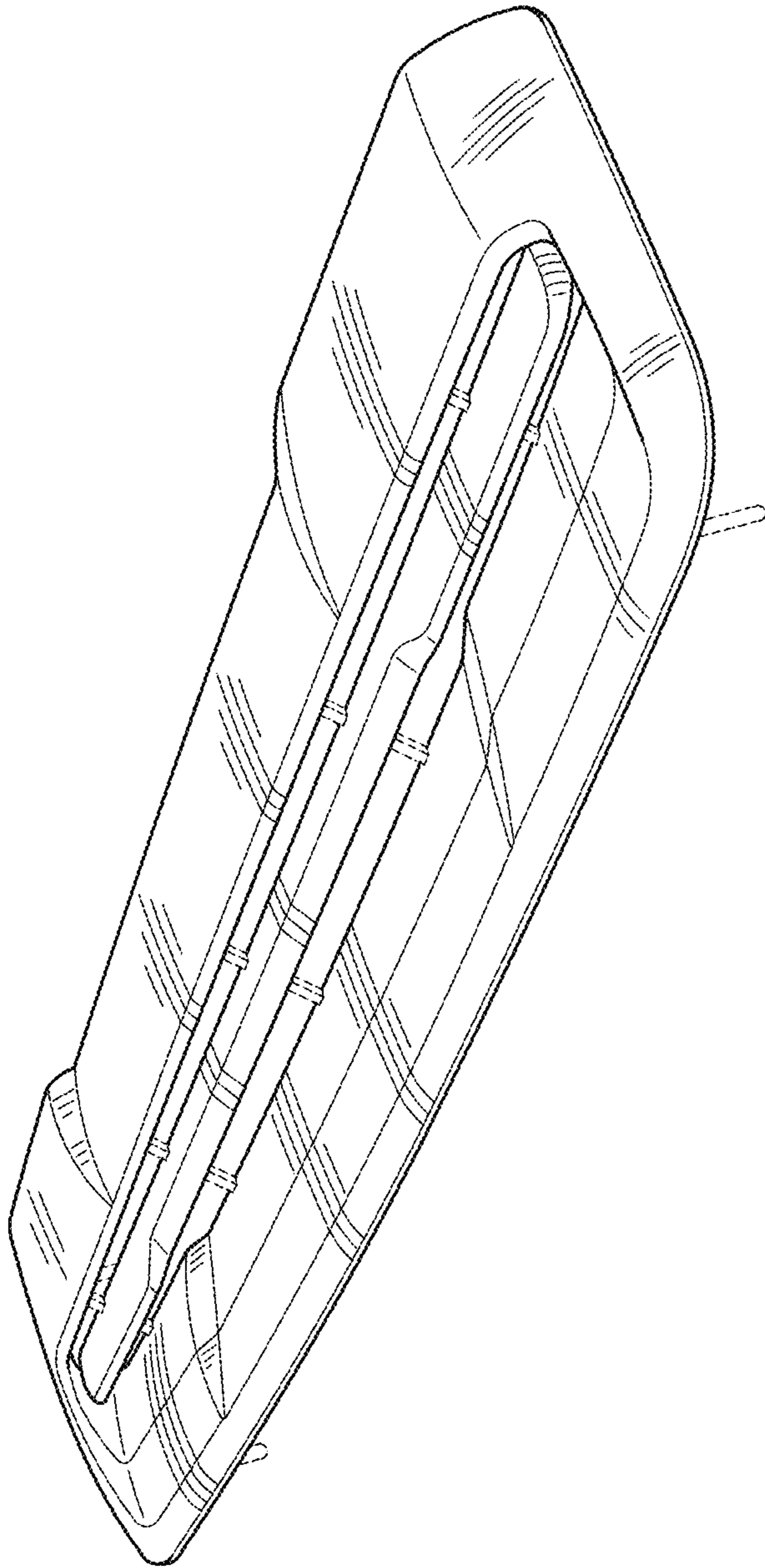

FIG. 1

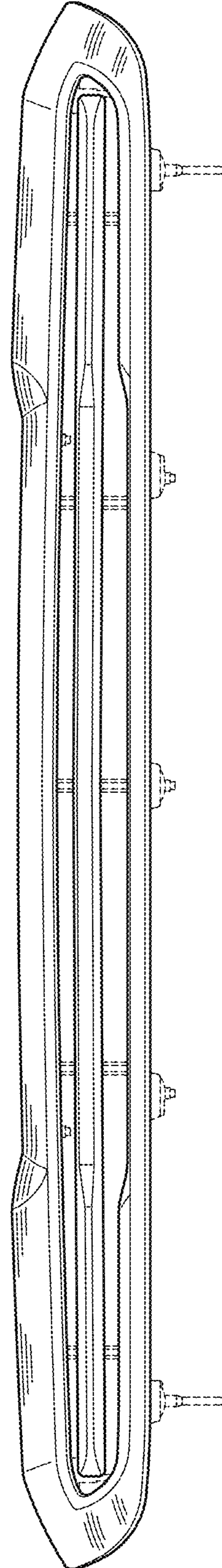

FIG. 2

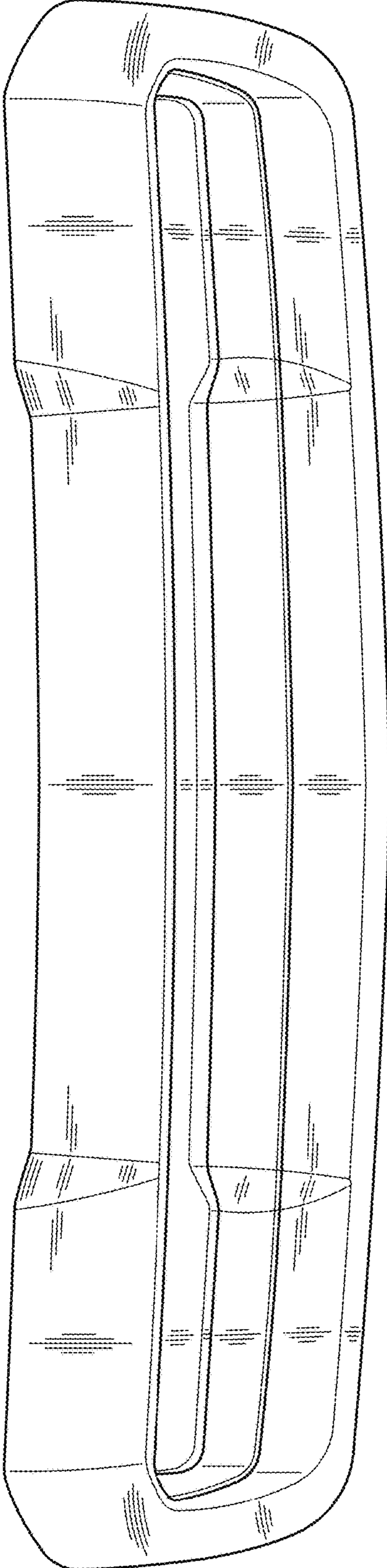

FIG. 3

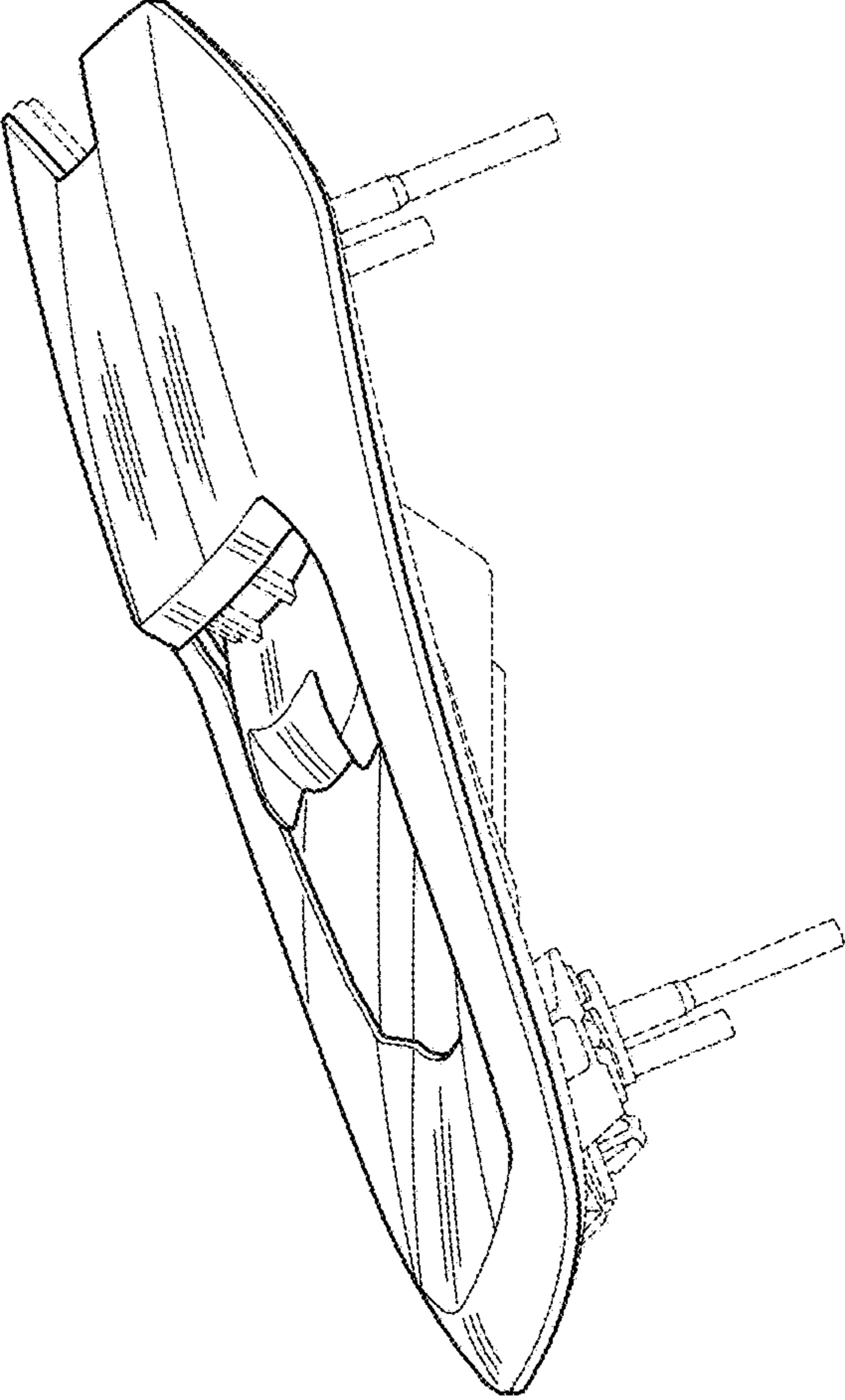

FIG. 4