



US00D868319S

(12) **United States Design Patent** (10) **Patent No.:** **US D868,319 S**
Thomas (45) **Date of Patent:** **** Nov. 26, 2019**

(54) **HEADLAMP**

(71) Applicant: **Jaguar Land Rover Limited**, Whitley, Coventry (GB)

(72) Inventor: **Gareth Thomas**, Coventry (GB)

(73) Assignee: **Jaguar Land Rover Limited**, Whitley, Coventry (GB)

(**) Term: **15 Years**

(21) Appl. No.: **29/682,593**

(22) Filed: **Mar. 6, 2019**

Related U.S. Application Data

(62) Division of application No. 29/591,387, filed on Jan. 19, 2007, now Pat. No. Des. 846,765.

(30) **Foreign Application Priority Data**

Jul. 20, 2016 (EM) 003313444-0001
Aug. 18, 2016 (EM) 003345610-0001
Aug. 18, 2016 (EM) 003345610-0002

(51) **LOC (12) Cl.** **26-06**

(52) **U.S. Cl.**
USPC **D26/28**

(58) **Field of Classification Search**

USPC D26/28-36, 139
CPC F21S 48/00; F21S 48/10; F21S 48/115;
F21S 48/225; F21S 48/1233; F21S
48/1266; F21S 48/1388; F21S 48/2268;
F21V 21/04; F21K 9/00; F21K 29/004;
B60Q 9/13; B60Q 9/135; B60Q 9/1375
See application file for complete search history.

(56) **References Cited**

U.S. PATENT DOCUMENTS

D538,956 S * 3/2007 Ishii D26/28
D544,614 S * 6/2007 Markefka D26/28

D637,319 S * 5/2011 Jeong D26/28
D739,578 S * 9/2015 Han D26/28
D779,090 S * 2/2017 Giolito D26/28
D787,726 S * 5/2017 Hong D26/28
D788,956 S * 6/2017 Hong D26/28

* cited by examiner

Primary Examiner — Marcus A Jackson

(74) *Attorney, Agent, or Firm* — Wood Herron & Evans LLP

(57) **CLAIM**

The ornamental design for a headlamp, as shown and described.

DESCRIPTION

FIG. 1 is a front view of a headlamp for a vehicle according to the present invention.

FIG. 2 is a front left perspective view of the headlamp shown in FIG. 1.

FIG. 3 is a left side view thereof; and,

FIG. 4 is a top view thereof.

In FIGS. 1-4 the broken lines which show portions of the headlamp are included for the purpose of illustrating environment and form no part of the claimed design.

FIG. 5 is a front left perspective view of the headlamp shown in FIGS. 1-4, with the headlamp mounted on a vehicle shown in de-emphasized and half-tone portions to illustrate environmental structure. These portions form no part of the claimed design. More particularly, in FIG. 5, the inventive headlamp is shown within the broken line, and any elements shown outside the broken line form no part of the claimed design, but are instead included to show environmental aspects thereof.

1 Claim, 5 Drawing Sheets

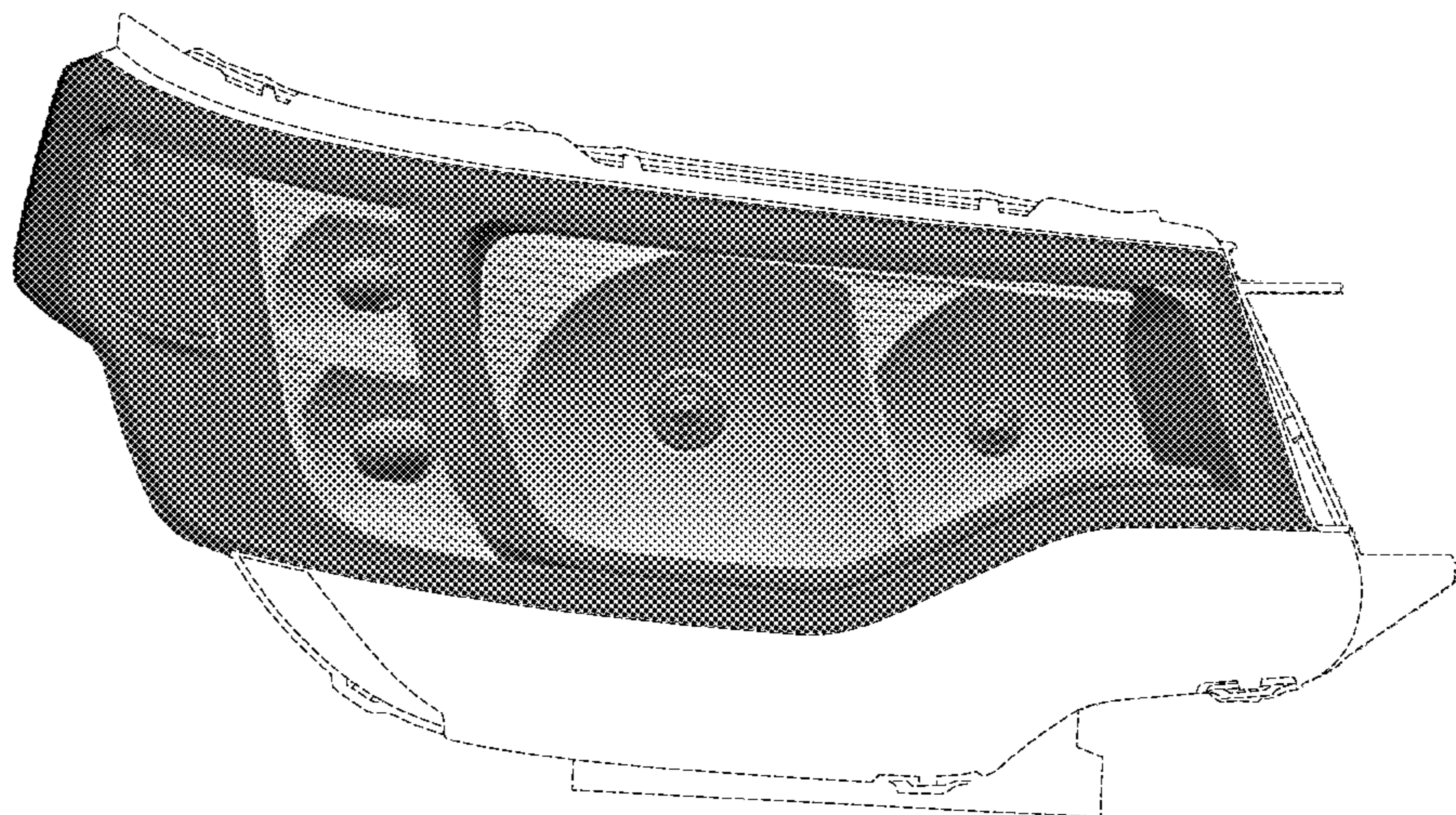

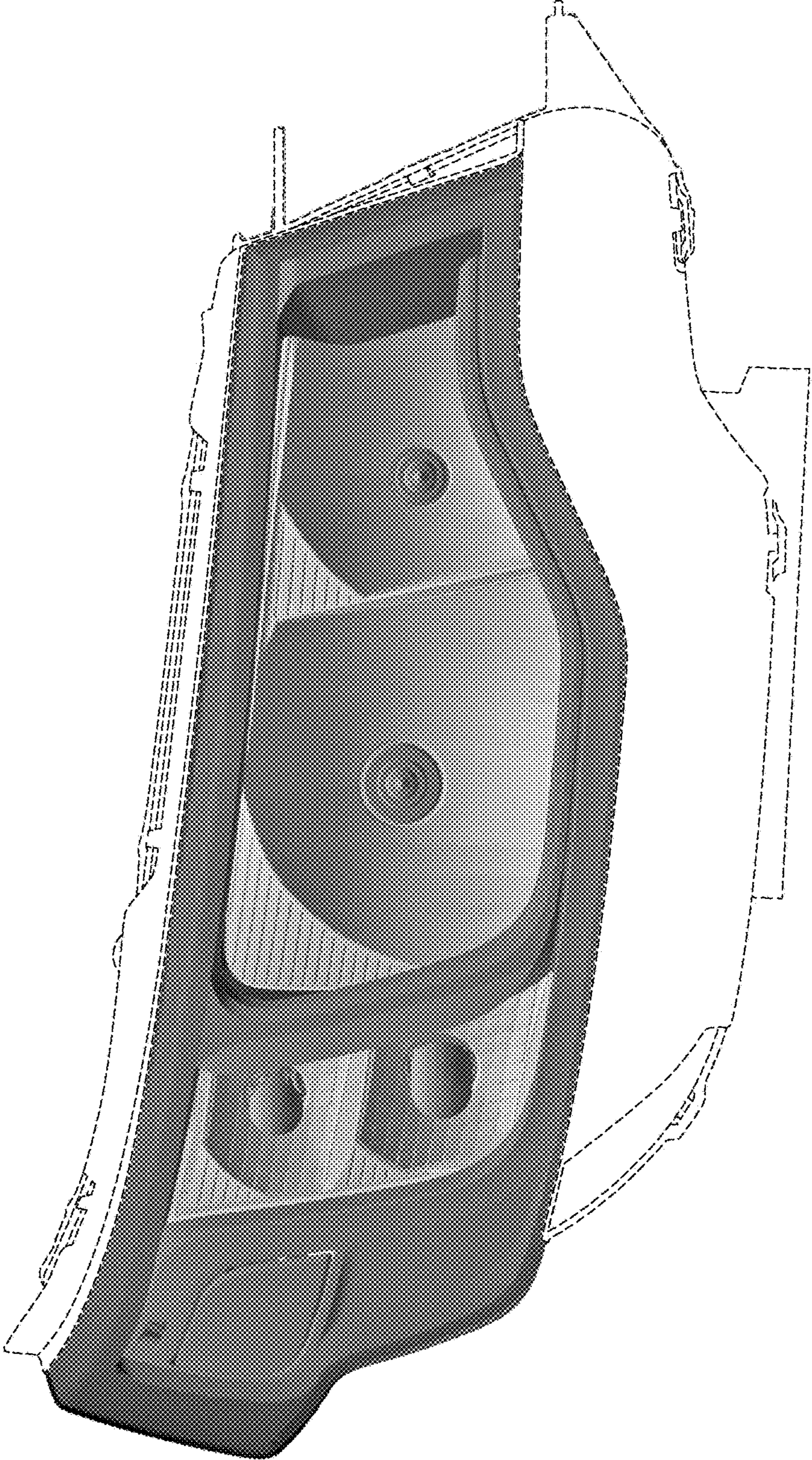

FIG. 1

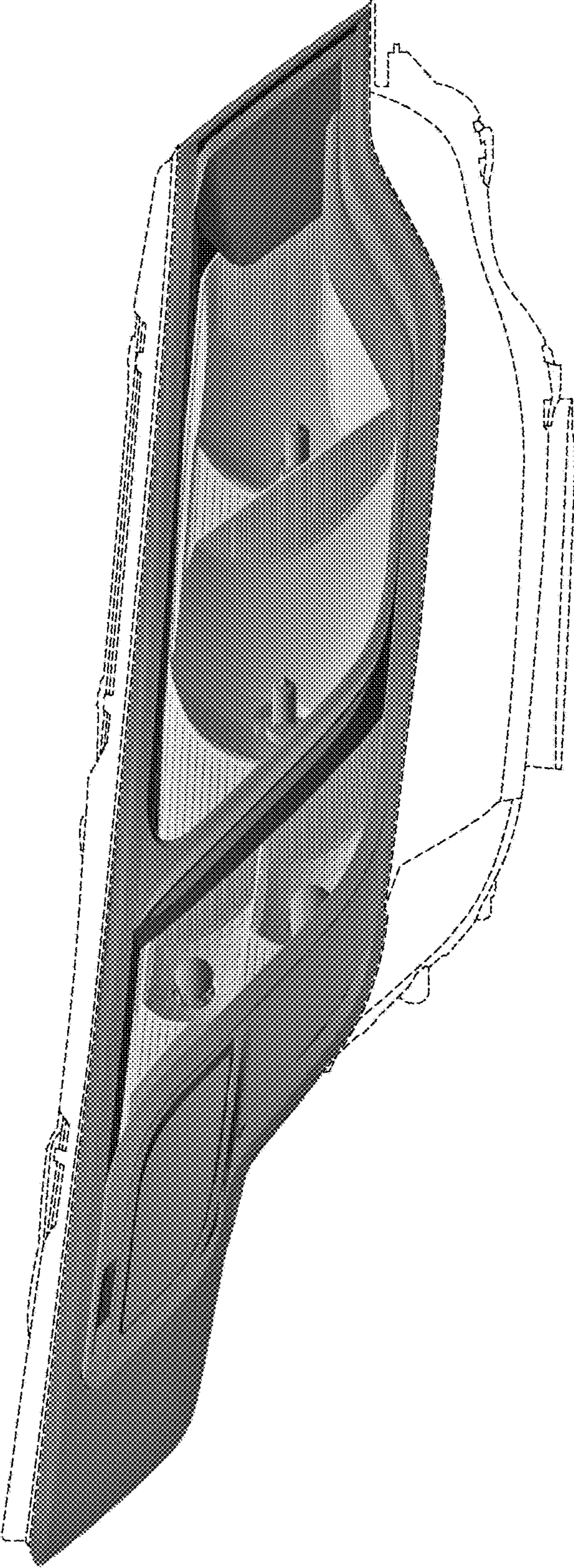

FIG. 2

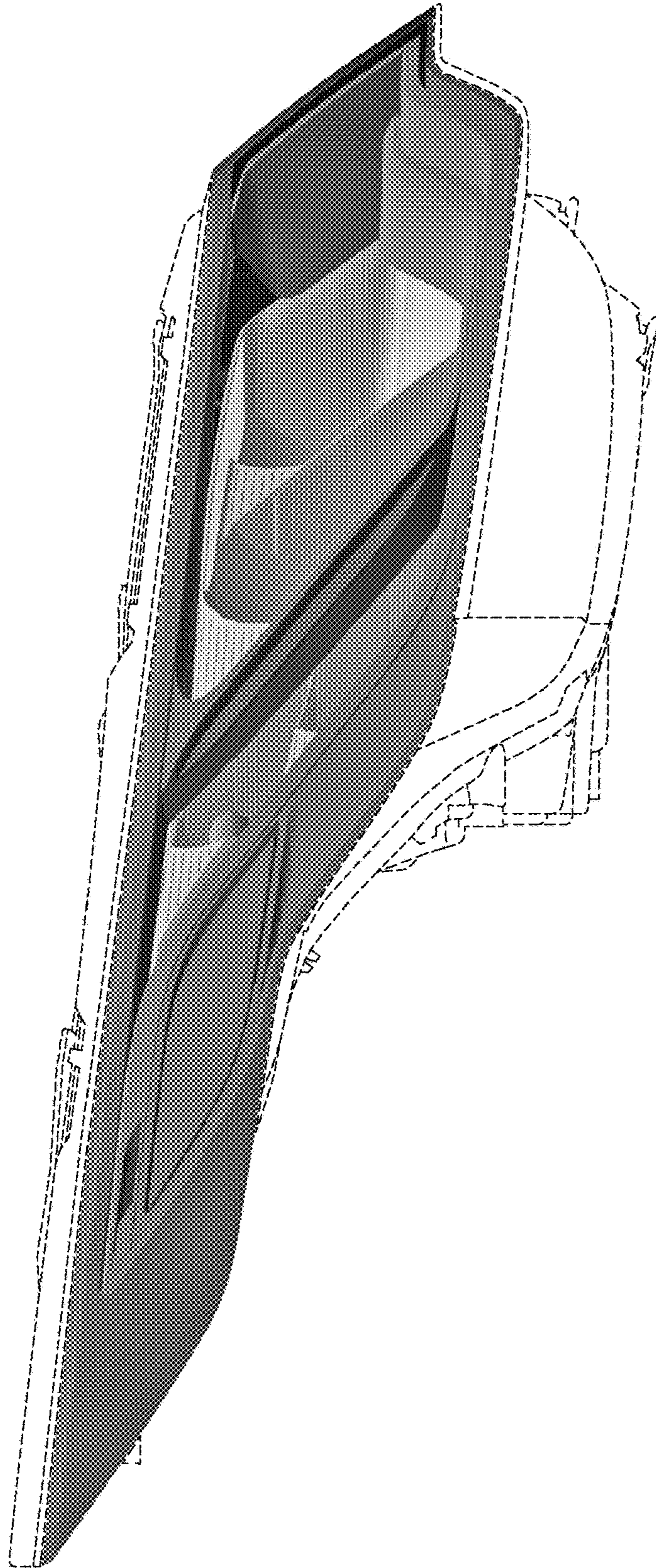

FIG. 3

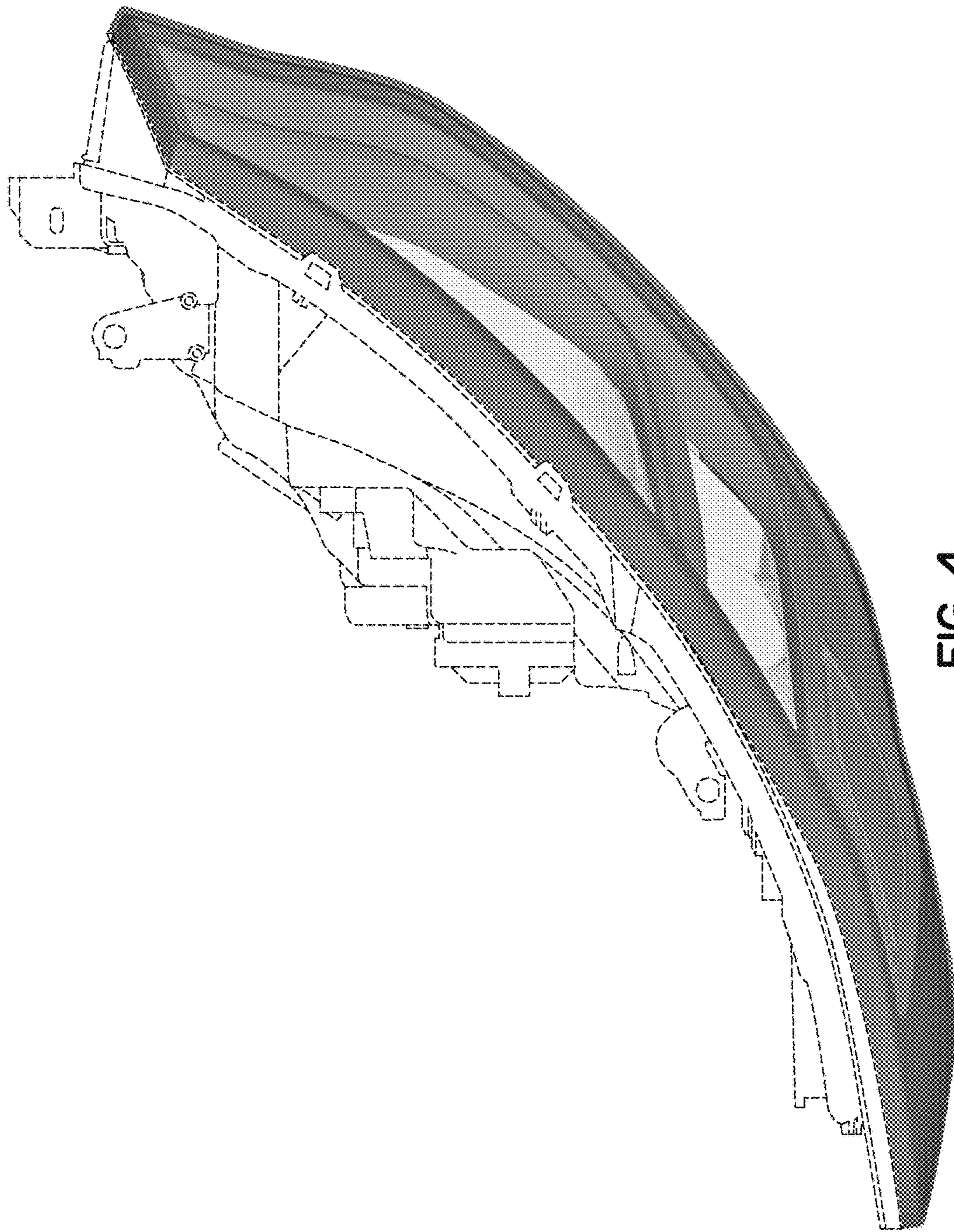

FIG. 4

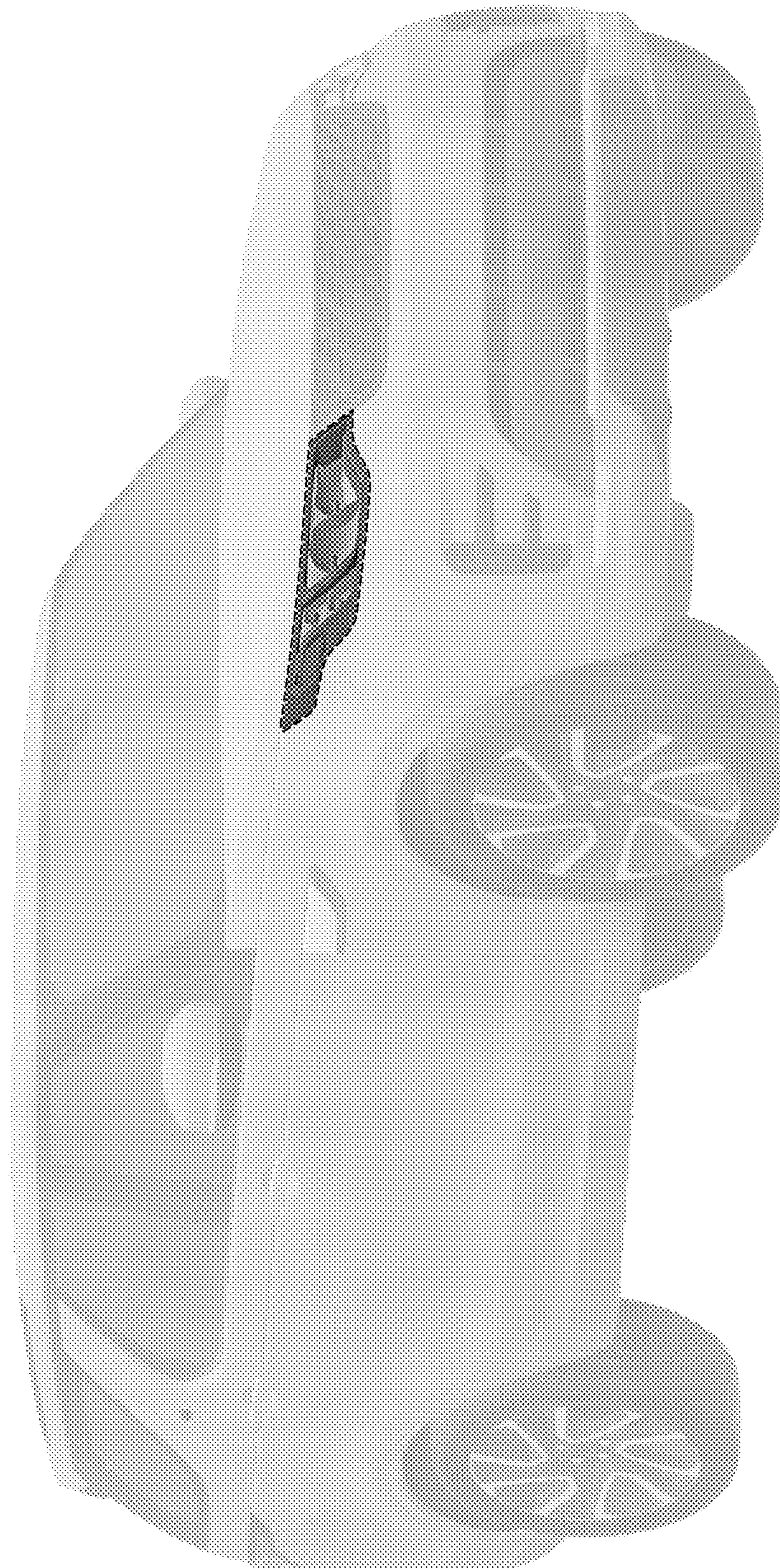

FIG. 5