

US00D867582S

(12) **United States Design Patent** (10) **Patent No.:** **US D867,582 S**
Mandaroux et al. (45) **Date of Patent:** **** Nov. 19, 2019**

(54) **SYRINGE DEVICE**

(71) Applicant: **Allergan, Inc.**, Irvine, CA (US)

(72) Inventors: **Bastien Mandaroux**, Metz-Tessy (FR);
Shushuo Wu, Thousand Oaks, CA
(US); **Lance Hussey**, Thousand Oaks,
CA (US)

(73) Assignee: **Allergan, Inc.**, Irvine, CA (US)

(**) Term: **15 Years**

(21) Appl. No.: **29/598,422**

(22) Filed: **Mar. 24, 2017**

(51) **LOC (12) Cl.** **24-02**

(52) **U.S. Cl.**
USPC **D24/114**

(58) **Field of Classification Search**
USPC D24/112-114, 108, 133, 130, 127, 186;
606/181, 185; 604/264, 272, 187, 181,
604/184, 227
CPC A61M 5/178; A61M 3/00; A61M 5/20;
A61M 5/31; A61M 5/3146; A61M
5/3129; A61M 5/3148; A61M 5/315
See application file for complete search history.

D224,066 S	6/1972	McDonald
3,720,211 A	3/1973	Kyrias
3,767,085 A	10/1973	Cannon et al.
3,807,048 A	4/1974	Malmin
3,910,282 A	10/1975	Messer et al.
3,916,777 A	11/1975	Earl
4,064,879 A	12/1977	Leibinsohn
4,240,423 A	12/1980	Akhavi
4,240,426 A	12/1980	Akhavi
4,273,122 A	6/1981	Whitney et al.
4,326,517 A	4/1982	Whitney et al.
4,346,708 A	8/1982	Leeven
4,444,560 A	4/1984	Jacklich
4,529,401 A	7/1985	Leslie et al.
4,617,016 A	10/1986	Blomberg
4,624,659 A	11/1986	Goldberg
4,671,255 A	6/1987	Dubrul et al.
4,695,273 A	9/1987	Brown
4,699,612 A	10/1987	Hamacher
4,710,172 A	12/1987	Jacklich
4,719,918 A	1/1988	Bonomo et al.
4,755,169 A	7/1988	Samoff
4,759,750 A	7/1988	Devries
4,800,901 A	1/1989	Rosenberg
4,832,692 A	5/1989	Box
4,841,948 A	6/1989	Bauser et al.
4,841,992 A	6/1989	Sasaki et al.
4,846,886 A	7/1989	Fey et al.
D303,010 S	8/1989	Jabbusch
4,869,717 A	9/1989	Adair
4,908,029 A	3/1990	Bark et al.
4,955,905 A	9/1990	Reed
4,957,744 A	9/1990	della Valle et al.
5,024,656 A	6/1991	Gasaway et al.
5,046,506 A	9/1991	Singer
5,066,303 A	11/1991	Bark et al.
5,092,348 A	3/1992	Dubrul et al.
5,100,390 A	3/1992	Lubeck et al.
5,104,375 A	3/1992	Lubeck et al.
5,116,358 A	5/1992	Granger et al.
5,127,436 A	7/1992	Campion et al.
5,141,496 A	8/1992	Dalto et al.
5,211,644 A	5/1993	VanBeek et al.
5,258,013 A	11/1993	Granger et al.
5,270,685 A	12/1993	Hagen
5,279,544 A	1/1994	Gross
5,295,980 A	3/1994	Ersek
5,305,788 A	4/1994	Mayeux
5,318,544 A	6/1994	Drypen
5,322,511 A	6/1994	Armbruster et al.
5,344,407 A	9/1994	Ryan
5,354,279 A	10/1994	Hofling
5,368,572 A	11/1994	Shirota

(56) **References Cited**
U.S. PATENT DOCUMENTS

1,250,114 A	12/1917	Bigelow et al.
1,558,037 A	10/1925	Morton
1,591,021 A	7/1926	Davis
2,007,140 A	7/1935	Ragnar
2,302,986 A	11/1942	Vollrath
2,491,978 A	12/1949	Helfman
2,551,902 A	5/1951	Rieck
2,737,946 A	3/1956	Hein, Jr.
2,853,070 A	9/1958	Julliard
3,086,530 A	4/1963	Groom
3,161,323 A	12/1964	Bent
D202,754 S	11/1965	Fnftolin
D214,112 S	5/1969	Langdon
3,517,668 A	6/1970	Brickson
3,595,231 A	7/1971	Pistor

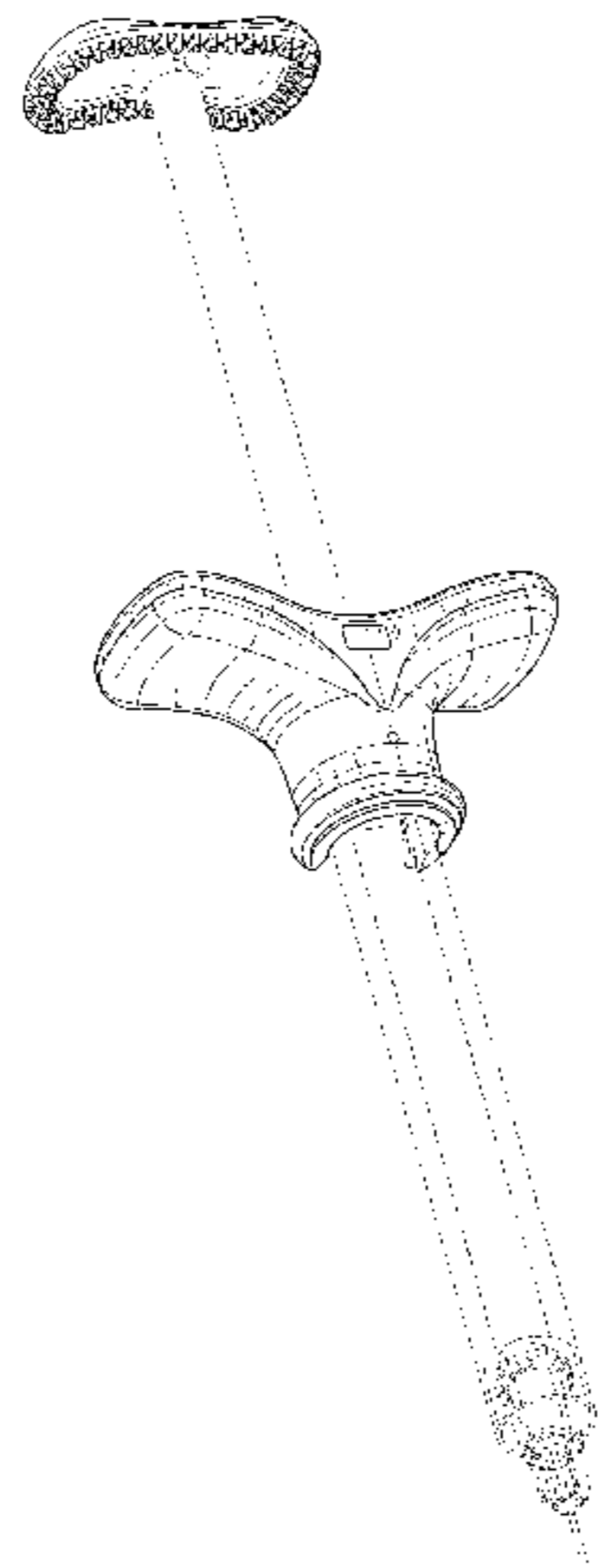

US D867,582 S

5,383,851 A	1/1995	Mackinnon, Jr.	7,664,545 B2	2/2010	Westersten et al.
5,405,330 A	4/1995	Zunitch et al.	7,666,339 B2	2/2010	Chaouk et al.
5,433,352 A	7/1995	Ronvig	D615,192 S	5/2010	Mudd et al.
5,478,327 A	12/1995	McGregor et al.	7,722,582 B2	5/2010	Lina et al.
5,540,657 A	7/1996	Kurjan	7,762,983 B2	7/2010	Arnisolle
5,549,672 A	8/1996	Maddock et al.	7,850,656 B2	12/2010	McKay et al.
5,611,809 A	3/1997	Marshall et al.	7,850,683 B2	12/2010	Elkins
D378,939 S	4/1997	Smith et al.	7,878,981 B2	2/2011	Strother et al.
5,690,618 A	11/1997	Smith et al.	7,896,837 B2	3/2011	Wilkinson et al.
5,752,970 A	5/1998	Yoon	D637,287 S	5/2011	Mudd et al.
5,807,340 A	9/1998	Pokras	7,998,170 B2	8/2011	Cunningham
5,817,033 A	10/1998	DeSantis	8,012,139 B2	9/2011	McKay et al.
5,824,335 A	10/1998	Dorigatti et al.	8,029,460 B2	10/2011	Rush et al.
5,846,225 A	12/1998	Rosengart et al.	8,066,629 B2	11/2011	Dlugos
5,941,845 A	8/1999	Tu et al.	8,083,722 B2	12/2011	McKay et al.
5,964,737 A	10/1999	Caizza	8,088,108 B2	1/2012	Kraft
D424,194 S	5/2000	Holdaway et al.	8,157,830 B2	4/2012	Wenchell
6,077,251 A	6/2000	Ting et al.	8,172,815 B2	5/2012	Down et al.
6,102,929 A	8/2000	Conway et al.	8,216,190 B2	7/2012	Gartstein
6,159,233 A	12/2000	Matsuzawa	8,236,021 B2	8/2012	Kluge
6,171,276 B1	1/2001	Lippe	8,291,768 B2	10/2012	Spiegel
6,183,434 B1	2/2001	Eppstein	8,303,518 B2	11/2012	Aceti
D441,077 S	4/2001	Garito et al.	8,303,545 B2	11/2012	Schrage
6,231,552 B1	5/2001	Jentzen	D674,086 S *	1/2013	Khalaj D24/114
6,231,570 B1	5/2001	Tu et al.	8,343,132 B2	1/2013	Heneveld et al.
6,283,951 B1	9/2001	Flaherty et al.	8,349,554 B2	1/2013	Bahrami et al.
6,293,925 B1	9/2001	Safabash et al.	8,353,871 B2	1/2013	Zimmerman
D449,379 S *	10/2001	Fuhr D24/133	8,366,643 B2	2/2013	Deem
6,303,518 B1	10/2001	Aceti	8,394,118 B2	3/2013	Jones et al.
6,312,412 B1	11/2001	Saied	8,409,147 B2	4/2013	Kraft
6,432,046 B1	8/2002	Yarush et al.	8,409,185 B2	4/2013	Burger
6,451,240 B1	9/2002	Sherman et al.	8,480,630 B2	7/2013	Mudd et al.
6,482,187 B1	11/2002	Gibbs	8,535,278 B2	9/2013	Mudd et al.
6,488,651 B1	12/2002	Morris	8,562,571 B2	10/2013	Mudd et al.
6,551,290 B1	4/2003	Elsberry et al.	8,603,028 B2	12/2013	Mudd et al.
6,595,960 B2	7/2003	West et al.	8,632,501 B2	1/2014	Kraft
6,607,512 B2	8/2003	Oliver	8,636,797 B2	1/2014	Chitre et al.
6,607,513 B1	8/2003	Down	8,657,786 B2	2/2014	Bahrami et al.
6,611,707 B1	8/2003	Prausnitz et al.	8,668,675 B2	3/2014	Chase
6,613,010 B2	9/2003	Castellano	8,708,965 B2	4/2014	Boyden
6,616,448 B2	9/2003	Friedman	8,712,815 B1	4/2014	Nichols et al.
D483,116 S *	12/2003	Castellano D24/112	8,821,446 B2	9/2014	Trautman
6,689,095 B1	2/2004	Garitano et al.	8,900,181 B2	12/2014	Knowlton
6,689,103 B1	2/2004	Palasis	8,900,186 B2	12/2014	Pettis et al.
6,780,171 B2	8/2004	Gabel	D721,803 S *	1/2015	Dubach D24/114
6,783,514 B2	8/2004	Tovey et al.	8,939,959 B2 *	1/2015	Baney A61M 5/31595 604/181
6,824,526 B2	11/2004	Castellano			
6,896,666 B2	5/2005	Kochamba	8,945,060 B2	2/2015	Bunch
6,901,850 B2	6/2005	Corominas	9,017,289 B2	4/2015	Backes
6,908,453 B2	6/2005	Fleming	9,017,318 B2	4/2015	Fourkas
6,936,297 B2	8/2005	Roby et al.	9,039,688 B2	5/2015	Palmer, III
6,945,952 B2	9/2005	Kwon	9,066,712 B2	6/2015	Fourkas
7,004,928 B2	2/2006	Aceti	9,072,498 B2	7/2015	Elkins
7,018,356 B2	3/2006	Wise et al.	9,101,346 B2	8/2015	Burger
7,033,337 B2	4/2006	Hjertman	9,113,855 B2	8/2015	Burger
7,041,088 B2	5/2006	Nawrocki et al.	D741,476 S *	10/2015	Hiraoka D24/114
7,047,070 B2	5/2006	Wilkinson et al.	9,149,331 B2	10/2015	Deem
7,048,729 B2	5/2006	Meglin et al.	9,155,584 B2	10/2015	Fourkas
7,097,631 B2	8/2006	Trautman	9,180,273 B2	11/2015	Konstantino
7,108,681 B2	9/2006	Gartstein	9,214,030 B2	12/2015	Sole et al.
7,115,108 B2	10/2006	Wilkinson et al.	9,227,023 B2	1/2016	Kraft
7,150,726 B2	12/2006	Dalton	9,241,753 B2	1/2016	Fourkas
D543,278 S *	5/2007	Numata D24/114	9,254,162 B2	2/2016	Burger
D557,337 S *	12/2007	Isaacs D19/149	9,289,605 B2	3/2016	Choi
7,302,885 B2	12/2007	Townsend	9,314,568 B2	4/2016	Gurtner et al.
7,361,163 B2	4/2008	Cohen	9,468,748 B2	10/2016	Bang
D576,276 S *	9/2008	Osyepka D24/130	D789,520 S *	6/2017	Tseng D24/114
7,419,472 B2	9/2008	Hibner et al.	D792,969 S *	7/2017	Taylor D24/130
7,442,187 B2	10/2008	Khayal et al.	2001/0008937 A1	7/2001	Callegaro et al.
D585,983 S *	2/2009	Wang D24/114	2002/0010433 A1	1/2002	Johnson
7,494,473 B2	2/2009	Eggers et al.	2002/0026039 A1	2/2002	Bellini et al.
7,504,386 B2	3/2009	Pressato et al.	2002/0065483 A1	5/2002	Leon
7,556,615 B2	7/2009	Pettis et al.	2002/0133114 A1	9/2002	Itoh
7,559,952 B2	7/2009	Pinchuck	2002/0151843 A1	10/2002	Correa et al.
7,588,547 B2	9/2009	Deem	2003/0028154 A1	2/2003	Ros
7,611,495 B1	11/2009	Gianturco	2003/0050602 A1	3/2003	Pettis et al.
D608,886 S *	1/2010	Rueckert D24/130	2003/0078912 A1	4/2003	Oliver
7,651,475 B2	1/2010	Angel	2003/0144632 A1	7/2003	Hommann et al.
7,662,110 B2	2/2010	Flaherty	2003/0181863 A1	9/2003	Ackley

US D867,582 S

Page 3

2003/0199883	A1	10/2003	Laks	2011/0230839	A1	9/2011	Bahrami et al.
2004/0010224	A1	1/2004	Bodmeier	2011/0238038	A1	9/2011	Sefi
2004/0015133	A1	1/2004	Karim	2011/0263724	A1	10/2011	Gurtner
2004/0092927	A1	5/2004	Podhajsky et al.	2011/0319865	A1	12/2011	Buss
2004/0147883	A1	7/2004	Tsai	2012/0041374	A1	2/2012	Lee
2004/0192643	A1	9/2004	Pressato et al.	2012/0089211	A1	4/2012	Curtis
2004/0220532	A1	11/2004	Caizza	2012/0101475	A1	4/2012	Wilmot
2005/0033362	A1	2/2005	Grafton	2012/0123194	A1	5/2012	Beckman
2005/0085767	A1	4/2005	Menassa	2012/0123537	A1	5/2012	Manesis et al.
2005/0131353	A1	6/2005	Mossanen-Shams et al.	2012/0141532	A1	6/2012	Blanda et al.
2005/0137496	A1	7/2005	Walsh et al.	2012/0150266	A1	6/2012	Shalev
2005/0177117	A1	8/2005	Crocker et al.	2012/0245629	A1	9/2012	Gross et al.
2005/0182446	A1	8/2005	DeSantis	2012/0259322	A1	10/2012	Fourkas
2005/0215956	A1	9/2005	Nerney	2012/0265064	A1	10/2012	Bahrami et al.
2005/0261633	A1	11/2005	Khalaj	2012/0265171	A1	10/2012	Thorne
2006/0041320	A1	2/2006	Matsuda	2012/0296206	A1	11/2012	Bahrami et al.
2006/0079765	A1	4/2006	Neer	2013/0012865	A1	1/2013	Sallberg et al.
2006/0089594	A1	4/2006	Landau	2013/0041346	A1	2/2013	Alon
2006/0150742	A1	7/2006	Esnouf	2013/0096531	A1	4/2013	Estepa et al.
2007/0038181	A1	2/2007	Melamud	2013/0122068	A1	5/2013	Fermanian et al.
2007/0083155	A1	4/2007	Muller	2013/0131632	A1	5/2013	Mudd et al.
2007/0085767	A1	4/2007	Jung et al.	2013/0131633	A1	5/2013	Mudd et al.
2007/0100363	A1	5/2007	Dollar et al.	2013/0150826	A1	6/2013	Almohizea
2007/0167920	A1	7/2007	Hommann	2013/0184648	A1	7/2013	Inou et al.
2007/0212385	A1	9/2007	David	2013/0184696	A1	7/2013	Fourkas
2007/0250010	A1	10/2007	Hohlfelder et al.	2013/0197446	A1	8/2013	Gustafsson
2007/0270710	A1	11/2007	Frass et al.	2013/0197449	A1	8/2013	Franklin et al.
2008/0015522	A1	1/2008	Yeshurun	2013/0211374	A1	8/2013	Hetherington
2008/0033347	A1	2/2008	D'Arrigo et al.	2013/0253289	A1	9/2013	Hadvary
2008/0058706	A1	3/2008	Zhang	2013/0274655	A1	10/2013	Jennings
2008/0058839	A1	3/2008	Nobles	2013/0274670	A1	10/2013	Mudd et al.
2008/0071385	A1	3/2008	Binette et al.	2013/0280755	A1	10/2013	Hubert
2008/0097325	A1	4/2008	Tanaka et al.	2013/0310763	A1	11/2013	Mudd et al.
2008/0108952	A1	5/2008	Horvath et al.	2014/0018770	A1	1/2014	Sutkin
2008/0114305	A1	5/2008	Gerondale	2014/0018835	A1	1/2014	Scherkowski
2008/0119797	A1	5/2008	Kim	2014/0066845	A1	3/2014	Mudd et al.
2008/0119876	A1	5/2008	Price et al.	2014/0088502	A1	3/2014	Matheny et al.
2008/0161772	A1	7/2008	Nayak	2014/0088553	A1	3/2014	Hetherington
2008/0167674	A1	7/2008	Bodduluri et al.	2014/0114279	A1	4/2014	Klinghoffer
2008/0188816	A1	8/2008	Shimazaki	2014/0121587	A1	5/2014	Sallberg et al.
2008/0200758	A1	8/2008	Orbay et al.	2014/0128685	A1	5/2014	Na
2008/0281278	A1	11/2008	Williams	2014/0128810	A1	5/2014	Ozawa et al.
2009/0088703	A1	4/2009	Azar	2014/0162901	A1	6/2014	Bahrami et al.
2009/0124996	A1	5/2009	Heneveld et al.	2014/0170299	A1	6/2014	Gill
2009/0125050	A1	5/2009	Dixon	2014/0228950	A1	8/2014	Whitcup et al.
2009/0143746	A1	6/2009	Mudd et al.	2014/0228971	A1	8/2014	Kim
2009/0187118	A1	7/2009	Kim	2014/0249504	A1	9/2014	Franklin et al.
2009/0234322	A1	9/2009	Fischer	2014/0257190	A1	9/2014	Yue et al.
2009/0240200	A1	9/2009	Heneveld et al.	2014/0309590	A1	10/2014	Bahrami et al.
2009/0247953	A1	10/2009	Yeshurun	2014/0343481	A1	11/2014	Ignon
2009/0259180	A1	10/2009	Choi	2014/0350514	A1	11/2014	Levin
2009/0275917	A1	11/2009	Azar	2014/0350516	A1	11/2014	Schwab
2009/0287161	A1	11/2009	Traub	2014/0350517	A1	11/2014	Dominguez
2009/0299328	A1	12/2009	Mudd et al.	2014/0350518	A1	11/2014	Franklin et al.
2010/0006095	A1	1/2010	Woodcock	2014/0350536	A1	11/2014	Allison
2010/0030152	A1	2/2010	Lee et al.	2015/0025459	A1	1/2015	Kimmell
2010/0069848	A1	3/2010	Alferness	2015/0025563	A1	1/2015	Mosharrafa et al.
2010/0100114	A1	4/2010	Berger	2015/0119875	A1	4/2015	Fischell et al.
2010/0121307	A1	5/2010	Lockard	2015/0126929	A1	5/2015	Franklin et al.
2010/0152675	A1	6/2010	McClintock	2015/0141956	A1	5/2015	Hoffman et al.
2010/0152679	A1	6/2010	Tezel	2015/0157809	A1	6/2015	Park et al.
2010/0179488	A1	7/2010	Spiegel	2015/0209265	A1	7/2015	Horne
2010/0256594	A1	10/2010	Kimmell	2015/0343147	A1	12/2015	Franklin et al.
2010/0256596	A1	10/2010	Chomas	2016/0007990	A1	1/2016	Solish et al.
2010/0280488	A1	11/2010	Pruitt et al.	2016/0058488	A1	3/2016	Fourkas
2010/0282774	A1	11/2010	Greter et al.	2016/0095984	A1	4/2016	Franklin et al.
2010/0286618	A1	11/2010	Choi	2016/0114144	A1	4/2016	Sumida
2011/0009808	A1	1/2011	AlGhamdi	2016/0144125	A1	5/2016	Franklin
2011/0021905	A1	1/2011	Patrick et al.	2016/0207253	A9	7/2016	Down et al.
2011/0028910	A1	2/2011	Weber	2016/0213854	A1	7/2016	Schwab et al.
2011/0092916	A1	4/2011	Tezel et al.	2016/0263358	A1	9/2016	Unger
2011/0137286	A1	6/2011	Mudd et al.	2016/0303314	A1	10/2016	Momose
2011/0152926	A1	6/2011	Vetrecin	2017/0080154	A1	3/2017	Mudd et al.
2011/0160674	A1	6/2011	Holmes et al.	2017/0290987	A1	10/2017	Mandaroux et al.
2011/0172645	A1	7/2011	Moga				
2011/0190974	A1	8/2011	Holmes et al.				
2011/0202014	A1	8/2011	Mutzbauer				
2011/0218494	A1	9/2011	Assaf				
2011/0218497	A1	9/2011	Assaf				

FOREIGN PATENT DOCUMENTS

CN	2535071	2/2003
CN	200960353	10/2007

EP	0362484	4/1990
EP	0205915	7/1990
EP	0167662	12/1990
EP	0648474	4/1995
EP	0809968	12/1997
EP	1051988	11/2000
EP	1486218	12/2004
EP	1395320	6/2006
EP	1859827	11/2007
EP	1923086	5/2008
EP	2189173	5/2010
EP	2335755	6/2011
EP	2422832	2/2012
EP	2103262	2/2013
EP	2184016	4/2013
EP	2671516	12/2013
FR	53011	9/1945
FR	2622457	5/1989
FR	2857654	1/2005
GB	2336783	5/2003
IN	209387	9/2007
KR	20120007473	1/2012
KR	101246570	3/2013
KR	20130036921	4/2013
KR	20130130436	12/2013
KR	20130132196	12/2013
KR	20140029007	3/2014
RU	2286803	11/2006
WO	WO 90/001349	2/1990
WO	WO 92/013579	8/1992
WO	WO 94/012228	6/1994
WO	WO 96/025965	8/1996
WO	WO 97/028840	8/1997
WO	WO 99/048601	9/1999
WO	WO 01/00190	1/2001
WO	WO 02/055135	7/2002
WO	WO 2004/022603	3/2004
WO	WO 2005/095225	10/2005
WO	WO 2006/065837	6/2006
WO	WO 2008/086479	8/2006
WO	WO 2006/118804	11/2006
WO	WO 2006/133111	12/2006
WO	WO 2007/092929	8/2007
WO	WO 2008/019265	2/2008
WO	WO 2008/053481	5/2008
WO	WO 2008/072229	6/2008
WO	WO 2008/079824	7/2008
WO	WO 2008/148071	12/2008
WO	WO 2009/003135	12/2008
WO	WO 2009/035680	3/2009
WO	WO 2009/091099	7/2009
WO	WO 2009/098666	8/2009
WO	WO 2009/158145	12/2009
WO	WO 2010/028025	3/2010
WO	WO 2011/016785	2/2011
WO	WO 2011/073796	6/2011
WO	WO 2011/075731	6/2011
WO	WO 2011/109129	9/2011
WO	WO 2011/109130	9/2011
WO	WO 2012/054301	4/2012
WO	WO 2012/054311	4/2012
WO	WO 2012/127856	9/2012
WO	WO 2012/172424	12/2012
WO	WO 2013/005881	1/2013
WO	WO 2013/054165	4/2013
WO	WO 2013/055832	4/2013
WO	WO 2013/082112	6/2013
WO	WO 2013/106857	8/2013
WO	WO 2014/026044	2/2014
WO	WO 2014/034032	3/2014
WO	WO 2012/174464	5/2014
WO	WO 2014/064536	5/2014
WO	WO 2014/189161	11/2014
WO	WO 2015/007243	1/2015
WO	WO 2015/020982	2/2015
WO	WO 2013/065235	4/2015
WO	WO 2015/064031	5/2015
WO	WO 2015/105269	7/2015
WO	WO 2015/127339	8/2015

WO	WO 2015/149031	10/2015
WO	WO 2016/008845	1/2016
WO	WO 2016/022865	2/2016
WO	WO 2016/033584	3/2016
WO	WO 2016/033586	3/2016

OTHER PUBLICATIONS

Bleyer, "SIS Facial Implant 510(k) Summary," Cook Biotech Inc. May 2005.

Davidenko et al., "Collagen-hyaluronic acid scaffolds for adipose tissue engineering", ACTA Biomaterialia, vol. 6, No. 10, Oct. 1, 2010, pp. 3957-3968.

Galderma, "New Restylane Skinboosters SmartClick delivery system wins prestigious Red Dot design award," Jul. 4, 2014, retrieved from <http://www.galderma.com/News/articleType/ArticleView/articleId/64/New-Restylane-Skinboosters-SmartClick-delivery-system-wins-prestigious-Red-Dot-design-award>.

Galderma, "Restylane Smart Click System Injection Device," Mar. 2015, retrieved from <http://www.red-dot-21.com/products/restylane-smart-click-system-injection-device-22169>.

Hamza et al., "A new external filling device in tissue expansion," Plastic and Reconstructive Surgery, Mar. 1998, vol. 101, No. 3, pp. 813-815.

Indian Patent Application No. 190/CHE/2002, filed Mar. 20, 2002, entitled A Subcutaneous Tissue Expander.

Indian Patent Application No. IN2012KO01267 for Tissue Expander.

International Search Report from PCT/US2016/021838, dated May 17, 2016.

International Search Report and Written Opinion from PCT/US2009/045831, dated Feb. 24, 2010.

International Search Report and Written Opinion from PCT/US2014/039265.

International Search Report and Written Opinion from PCT/US2014/039266.

Park et al., "Biological characterization of EDC-crosslinked collagen-hyaluronic acid matrix in dermal tissue restoration", Biomaterials, Elsevier Science Publishers BV, vol. 24, No. 9, Apr. 1, 2003, pp. 1631-1641.

Prime Journal, "Galderma to launch two new syringes at AMWC 2014," Mar. 2014.

Turtlepin, "The Painless Direct Dermal Injector" Product Information, JM Biotech Co Ltd, 2013.

Wang et al., "In vivo stimulation of de novo collagen production caused by cross-linked hyaluronic acid dermal filler injections in photodamaged human skin.", Archives of Dermatology, American Medical Association, US, vol. 143, No. 2, Feb. 1, 2007, pp. 155-163.

* cited by examiner

Primary Examiner — David G Muller
 (74) Attorney, Agent, or Firm — Nathan S. Smith;
 Morgan, Lewis & Bockius LLP

(57) CLAIM

The ornamental design for a syringe device, as shown and described.

DESCRIPTION

The patent or application file contains at least one drawing executed in color. Copies of this patent or patent application publication with color drawing(s) will be provided by the Office upon request and payment of the necessary fee.

FIG. 1 is a front, top perspective view of a syringe device; FIG. 2 is a right side elevation view of the syringe device of FIG. 1; FIG. 3 is a left side elevation view of the syringe device of FIG. 1; FIG. 4 is a top plan view of the syringe device of FIG. 1;

FIG. 5 is a bottom plan view of the syringe device of FIG. 1;
FIG. 6 is a rear elevation view of the syringe device of FIG. 1;
FIG. 7 is a front elevation view of the syringe device of FIG. 1;
FIG. 8 is a front, top perspective view of a second embodiment of the syringe device;
FIG. 9 is a right side elevation view of the syringe device of FIG. 8;
FIG. 10 is a left side elevation view of the syringe device of FIG. 8;
FIG. 11 is a top plan view of the syringe device of FIG. 8;
FIG. 12 is a bottom plan view of the syringe device of FIG. 8;
FIG. 13 is a rear elevation view of the syringe device of FIG. 8;
FIG. 14 is a front elevation view of the syringe device of FIG. 8;
FIG. 15 is a front, top perspective view of a third embodiment of the syringe device;
FIG. 16 is a right side elevation view of the syringe device of FIG. 15;
FIG. 17 is a left side elevation view of the syringe device of FIG. 15;
FIG. 18 is a top plan view of the syringe device of FIG. 15;
FIG. 19 is a bottom plan view of the syringe device of FIG. 15;
FIG. 20 is a rear elevation view of the syringe device of FIG. 15;
FIG. 21 is a front elevation view of the syringe device of FIG. 15;
FIG. 22 is a front, top perspective view of a fourth embodiment of the syringe device;
FIG. 23 is a right side elevation view of the syringe device of FIG. 22;
FIG. 24 is a left side elevation view of the syringe device of FIG. 22;

FIG. 25 is a top plan view of the syringe device of FIG. 22;
FIG. 26 is a bottom plan view of the syringe device of FIG. 22;
FIG. 27 is a rear elevation view of the syringe device of FIG. 22;
FIG. 28 is a front elevation view of the syringe device of FIG. 22;
FIG. 29 is a front, top perspective view of a fifth embodiment of the syringe device;
FIG. 30 is a right side elevation view of the syringe device of FIG. 29;
FIG. 31 is a left side elevation view of the syringe device of FIG. 29;
FIG. 32 is a top plan view of the syringe device of FIG. 29;
FIG. 33 is a bottom plan view of the syringe device of FIG. 29;
FIG. 34 is a rear elevation view of the syringe device of FIG. 29;
FIG. 35 is a front elevation view of the syringe device of FIG. 29;
FIG. 36 is a front, top perspective view of a sixth embodiment of the syringe device;
FIG. 37 is a right side elevation view of the syringe device of FIG. 36;
FIG. 38 is a left side elevation view of the syringe device of FIG. 36;
FIG. 39 is a top plan view of the syringe device of FIG. 36;
FIG. 40 is a bottom plan view of the syringe device of FIG. 36;
FIG. 41 is a rear elevation view of the syringe device of FIG. 36; and,
FIG. 42 is a front elevation view of the syringe device of FIG. 36.
The broken lines shown in the figures are included for the purpose of illustration and form no part of the claimed design.

**1 Claim, 24 Drawing Sheets
(16 of 24 Drawing Sheet(s) Filed in Color)**

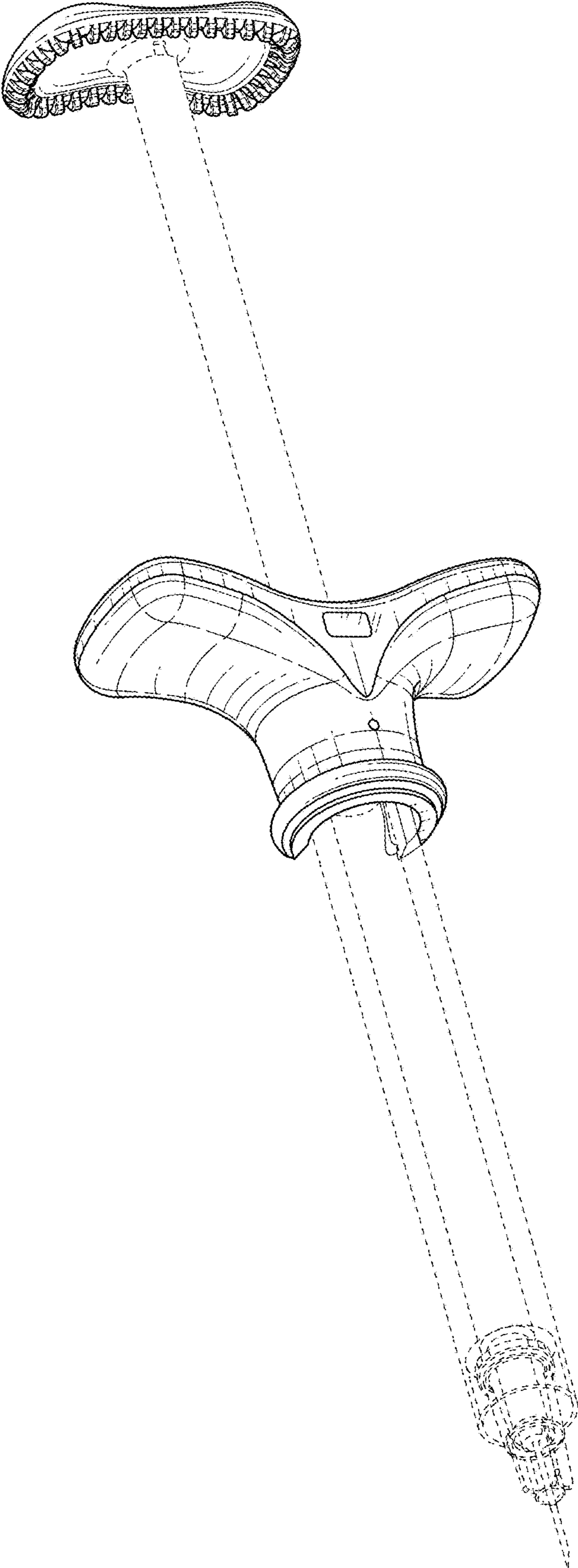

FIG. 1

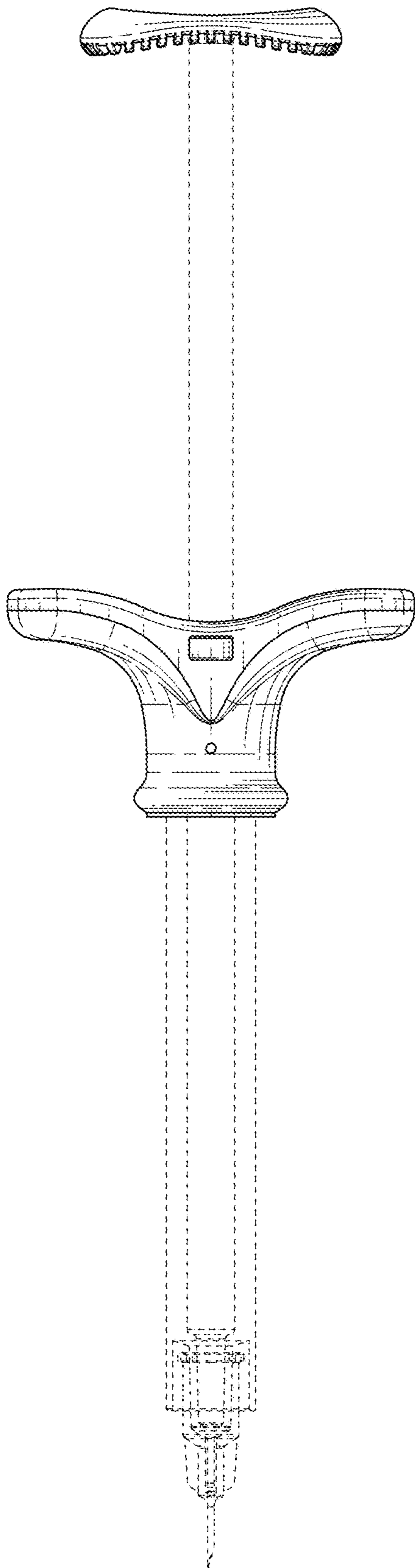

FIG. 2

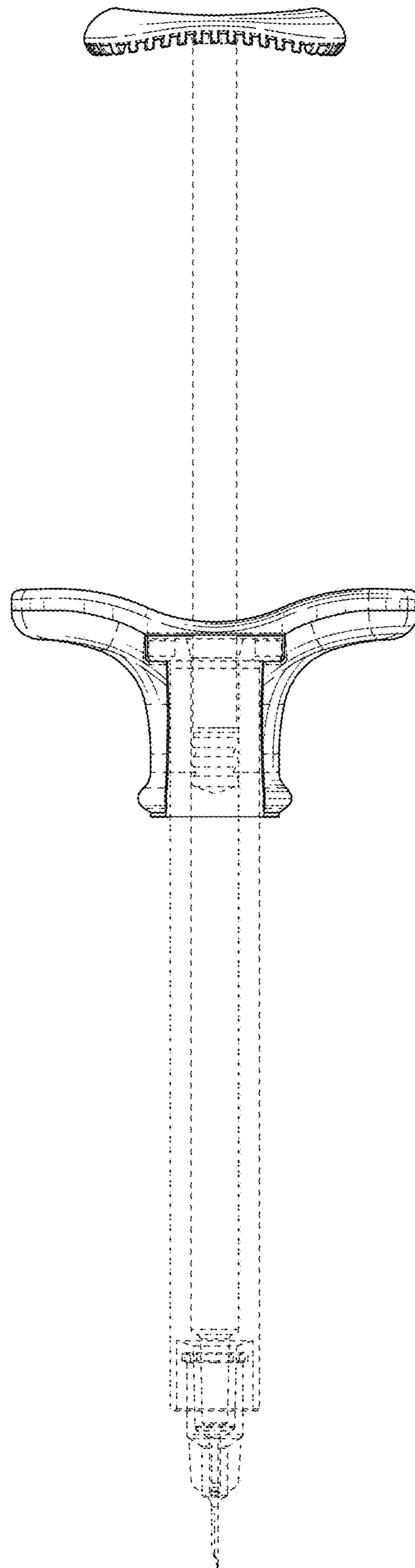

FIG. 3

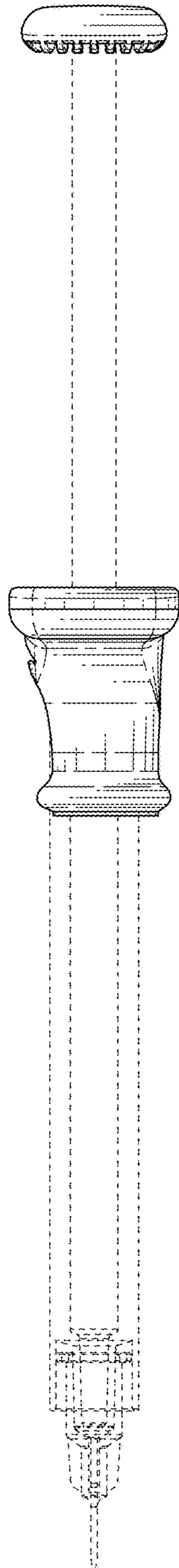

FIG. 4

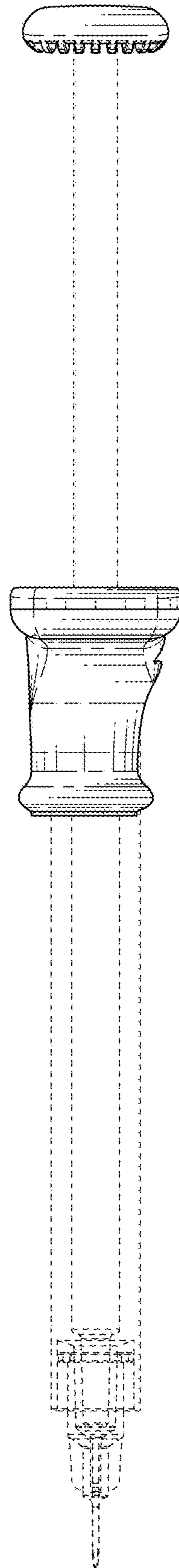

FIG. 5

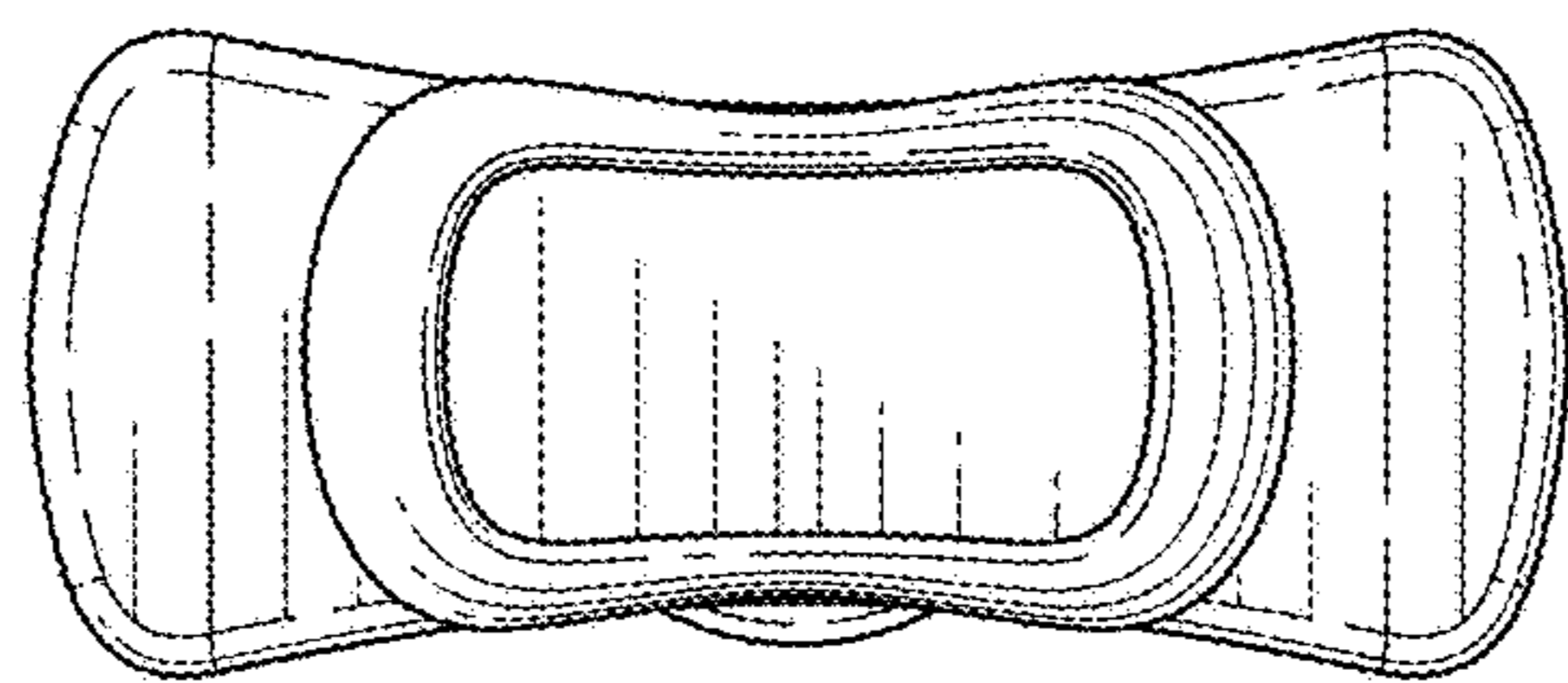

FIG. 6

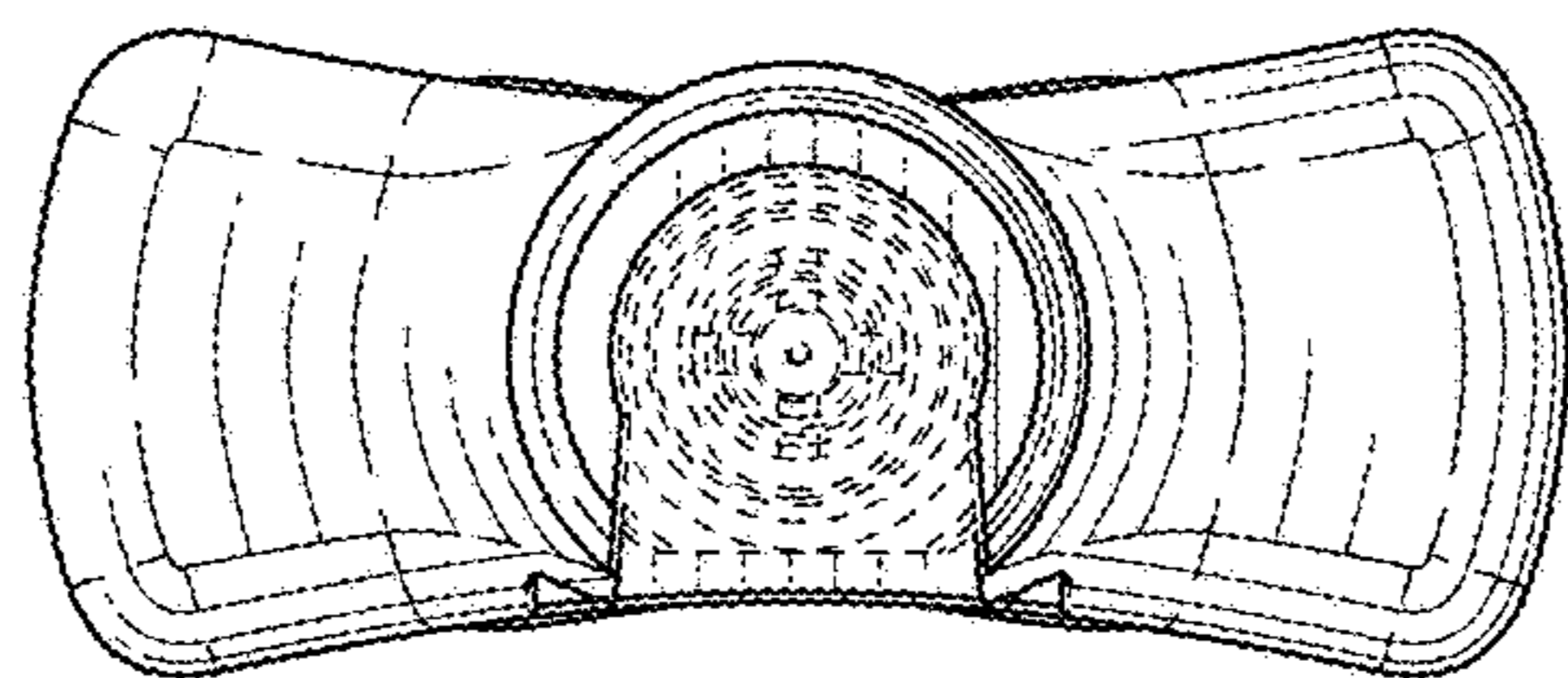

FIG. 7

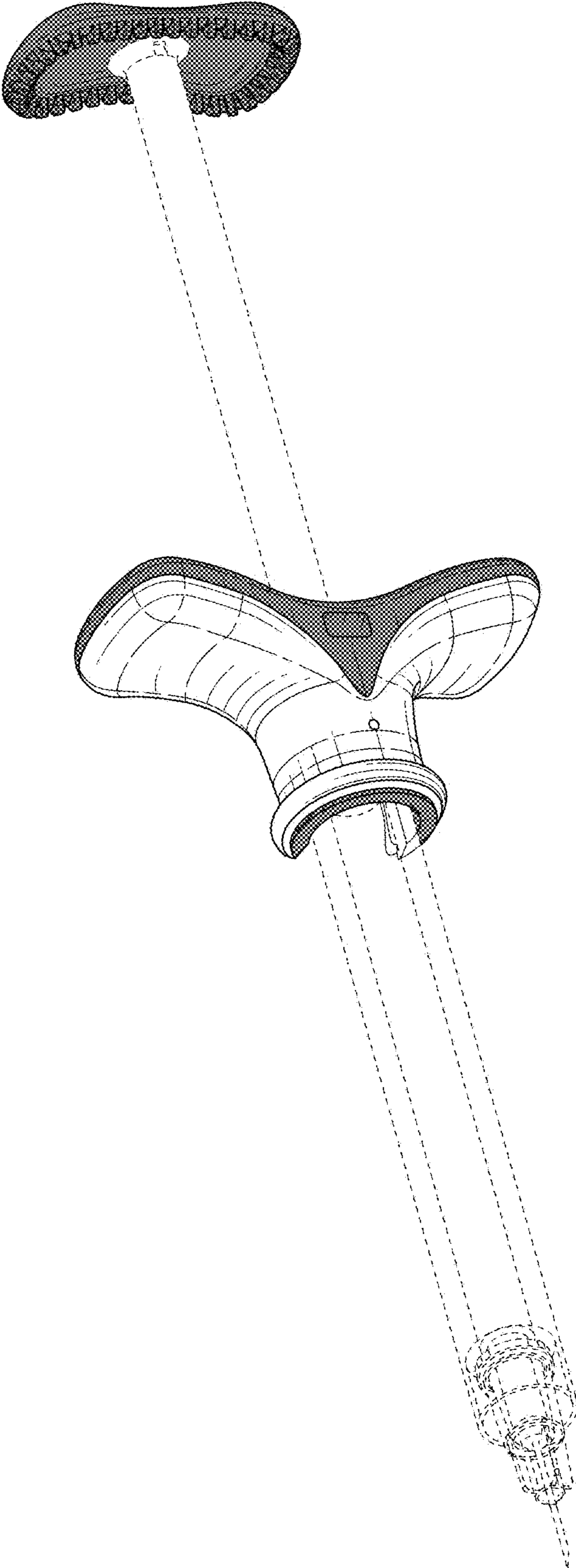

FIG. 8

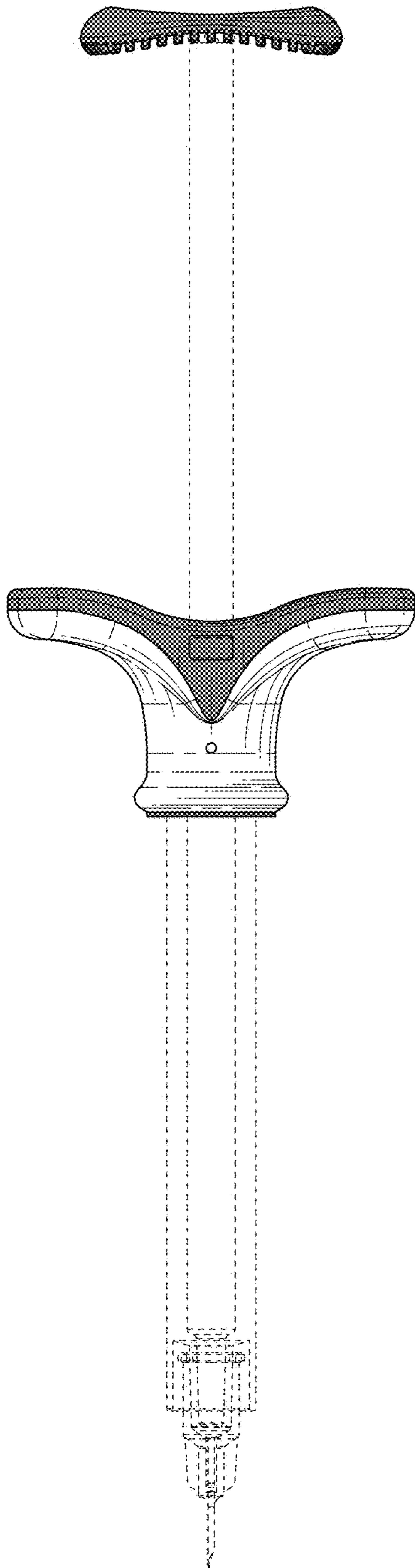

FIG. 9

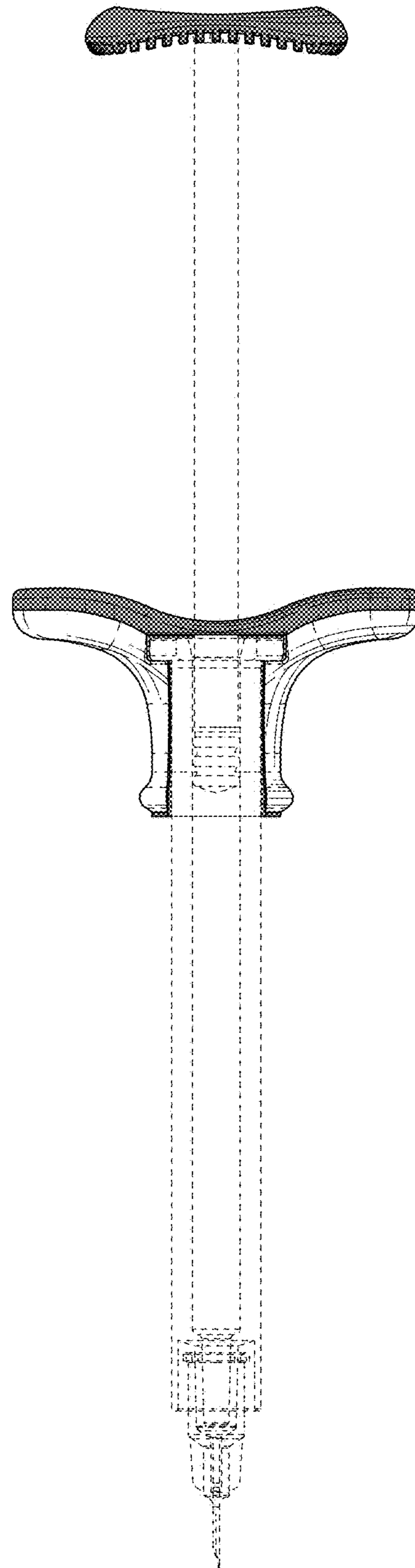

FIG. 10

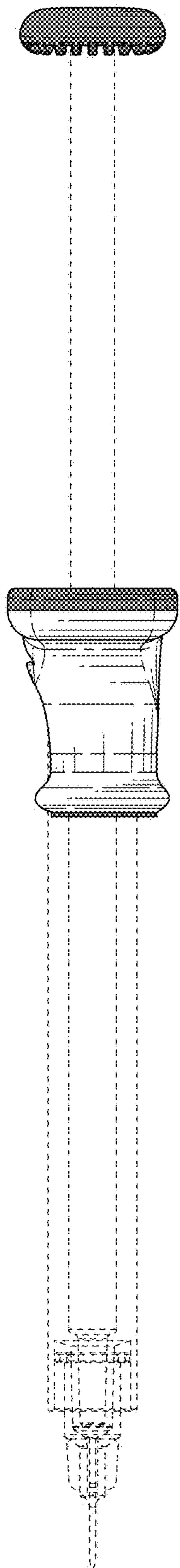

FIG. 11

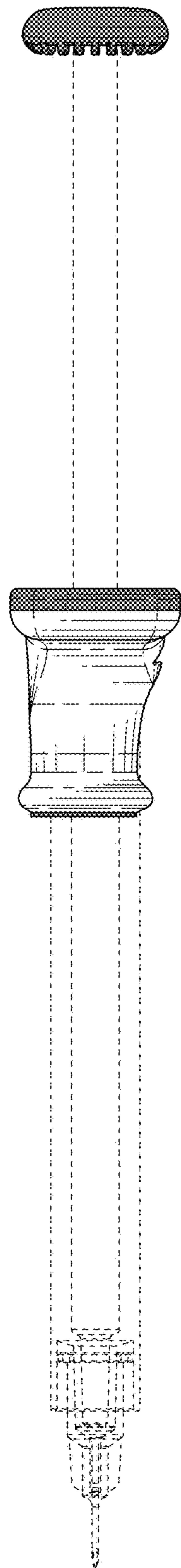

FIG. 12

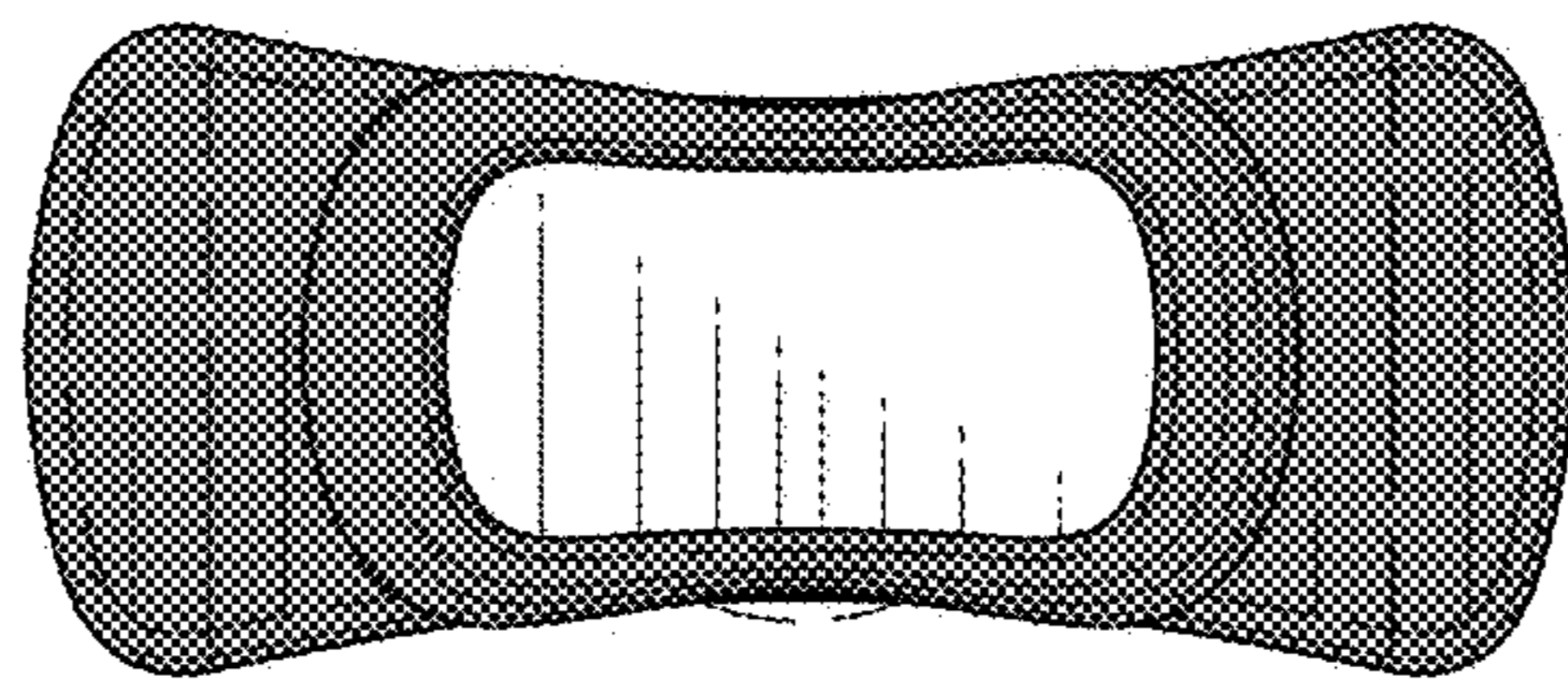

FIG. 13

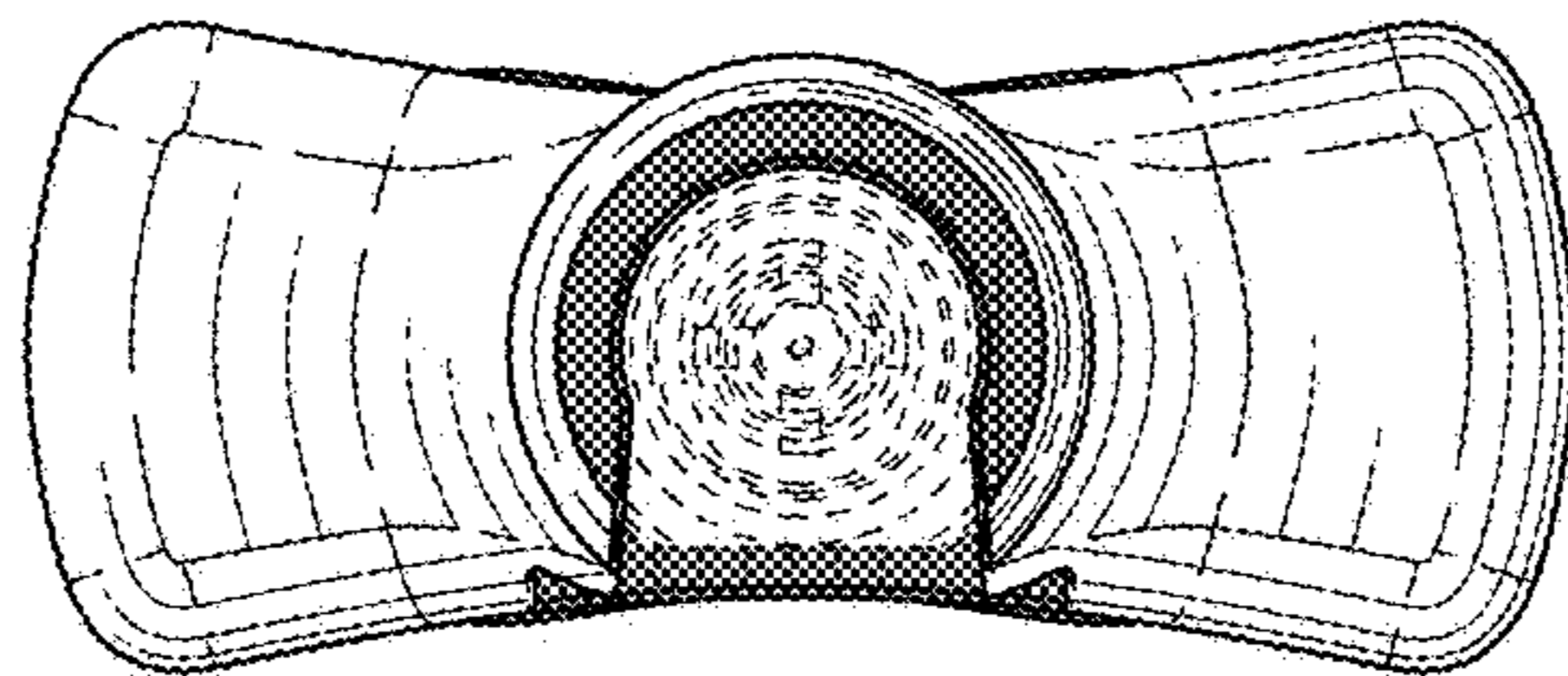

FIG. 14

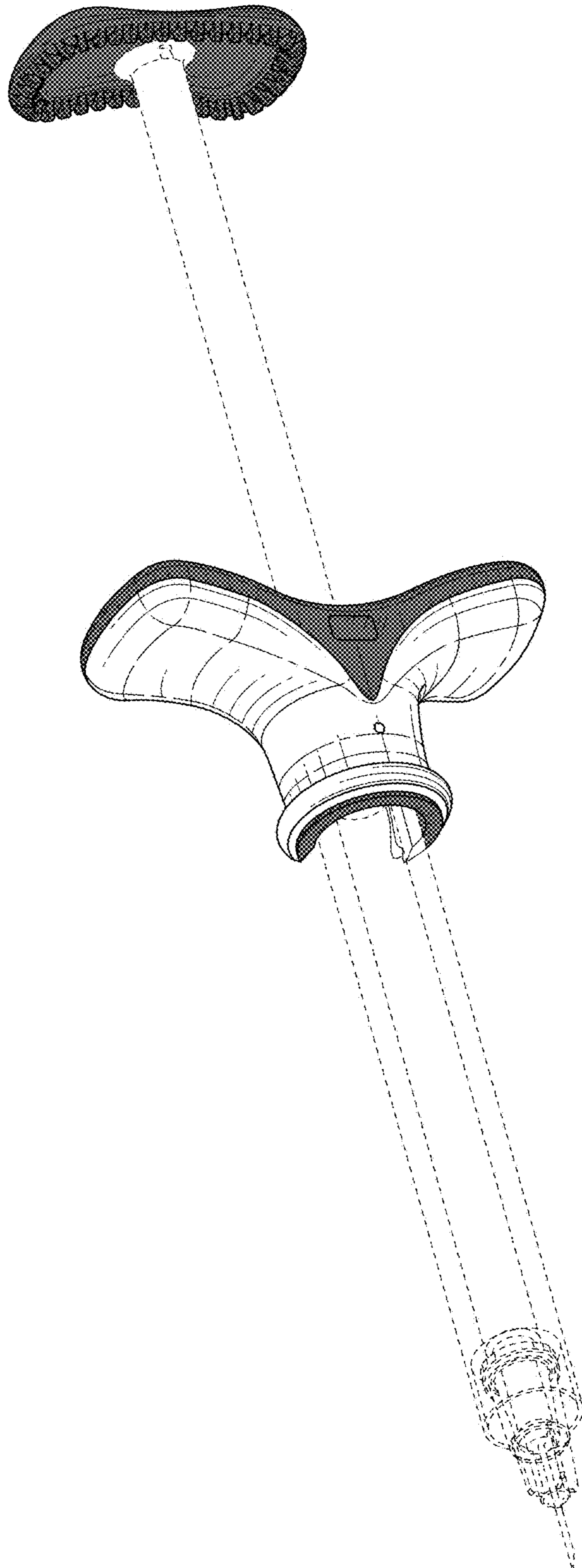

FIG. 15

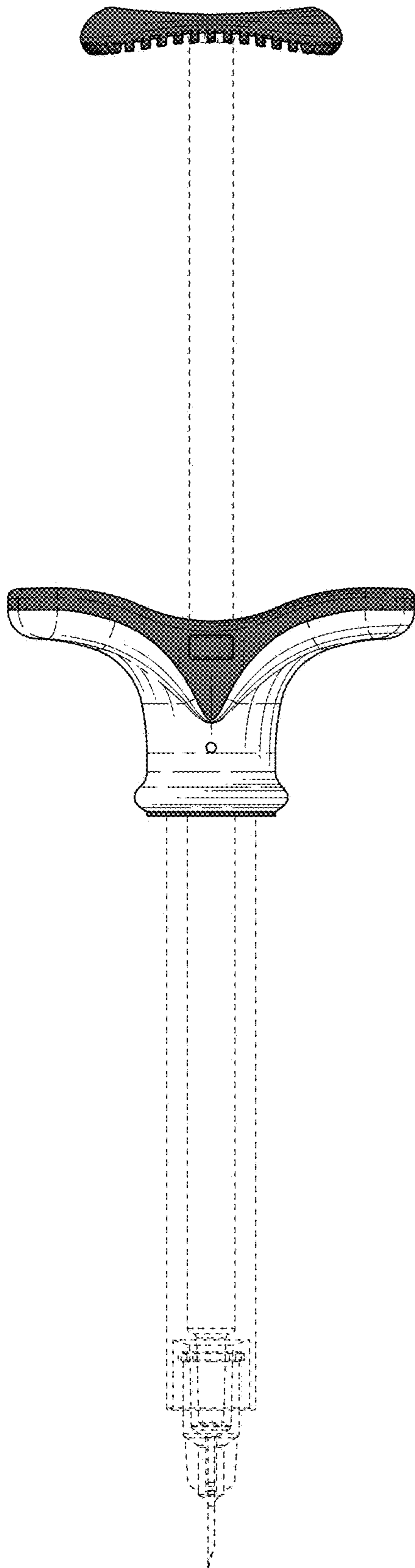

FIG. 16

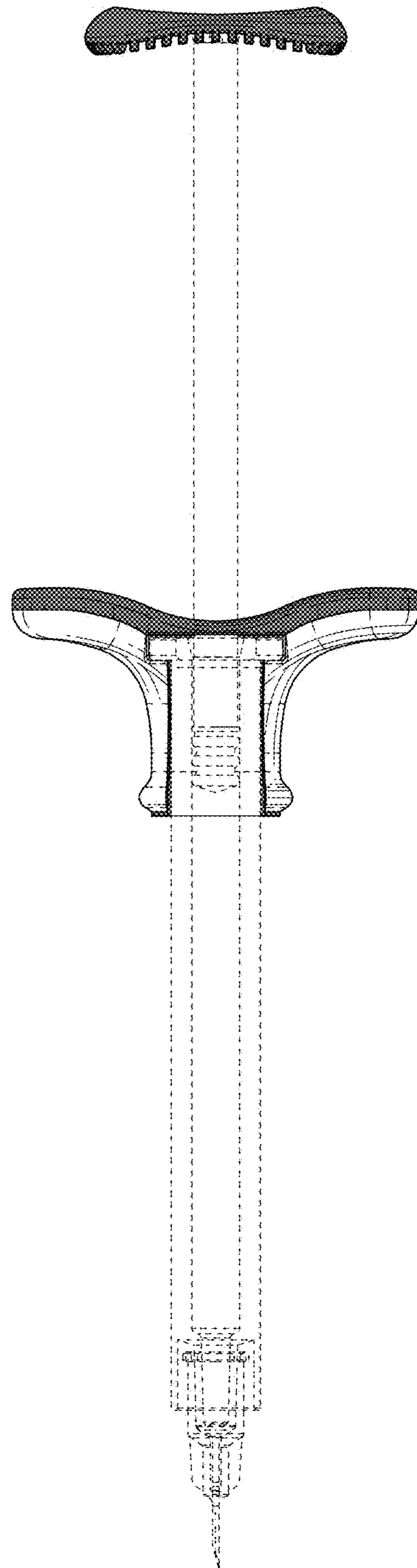

FIG. 17

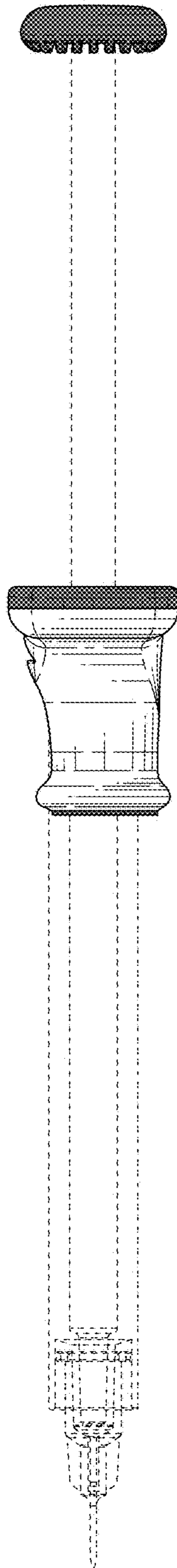

FIG. 18

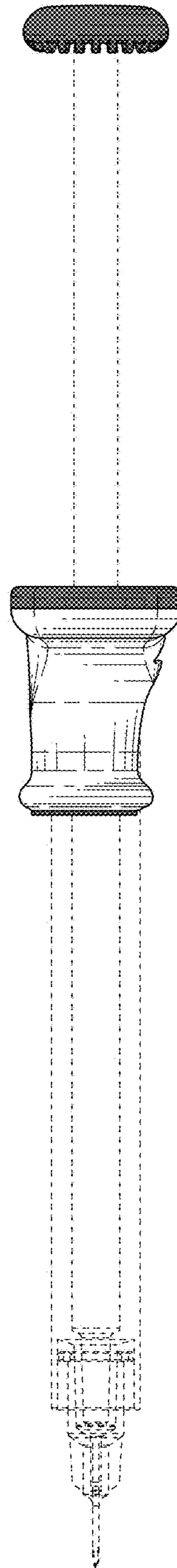

FIG. 19

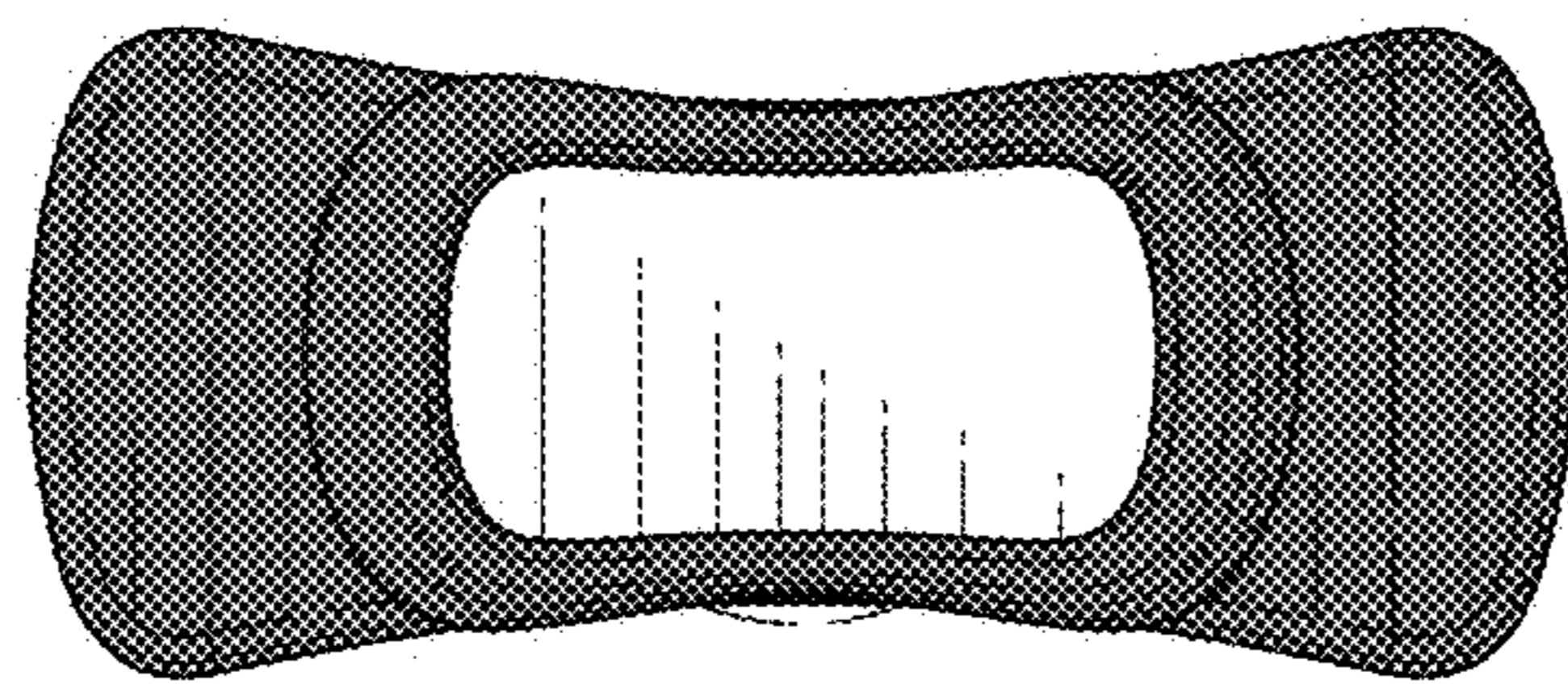

FIG. 20

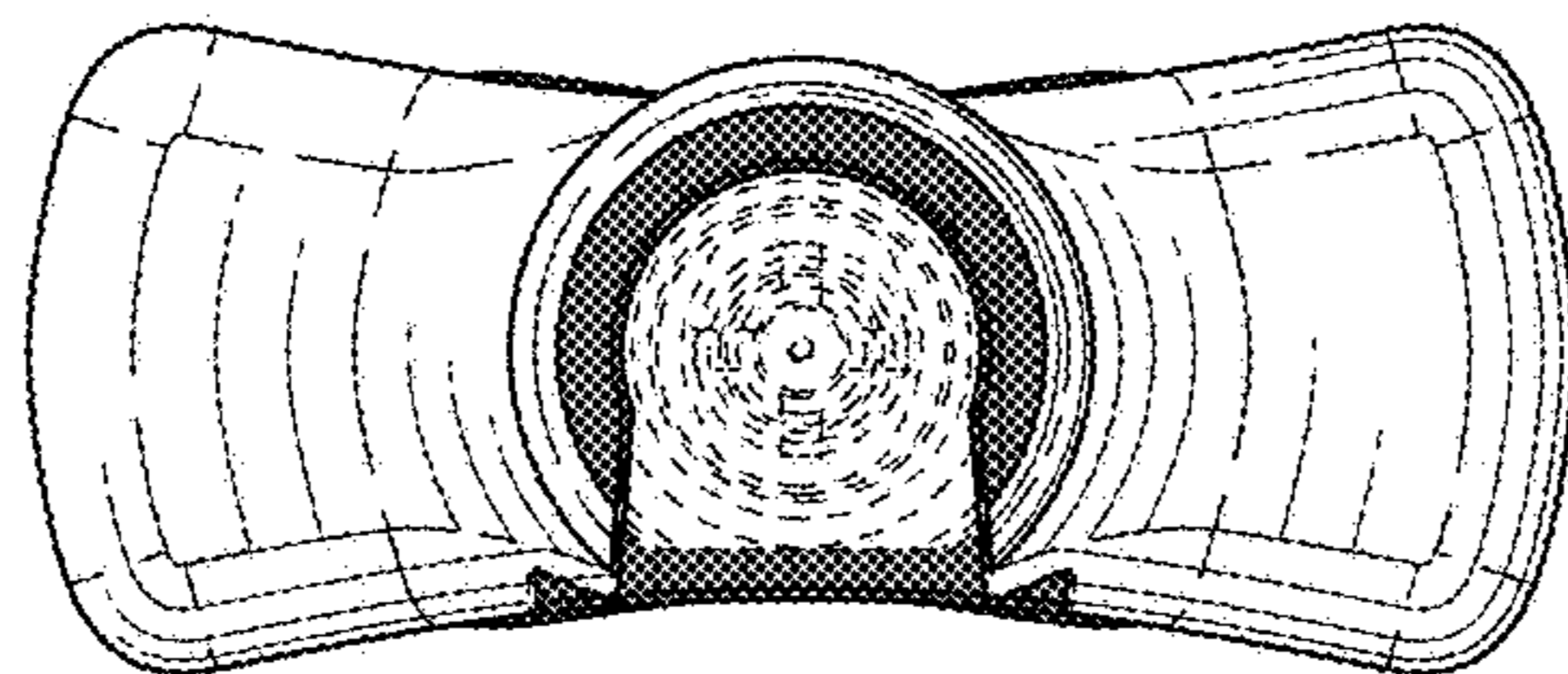

FIG. 21

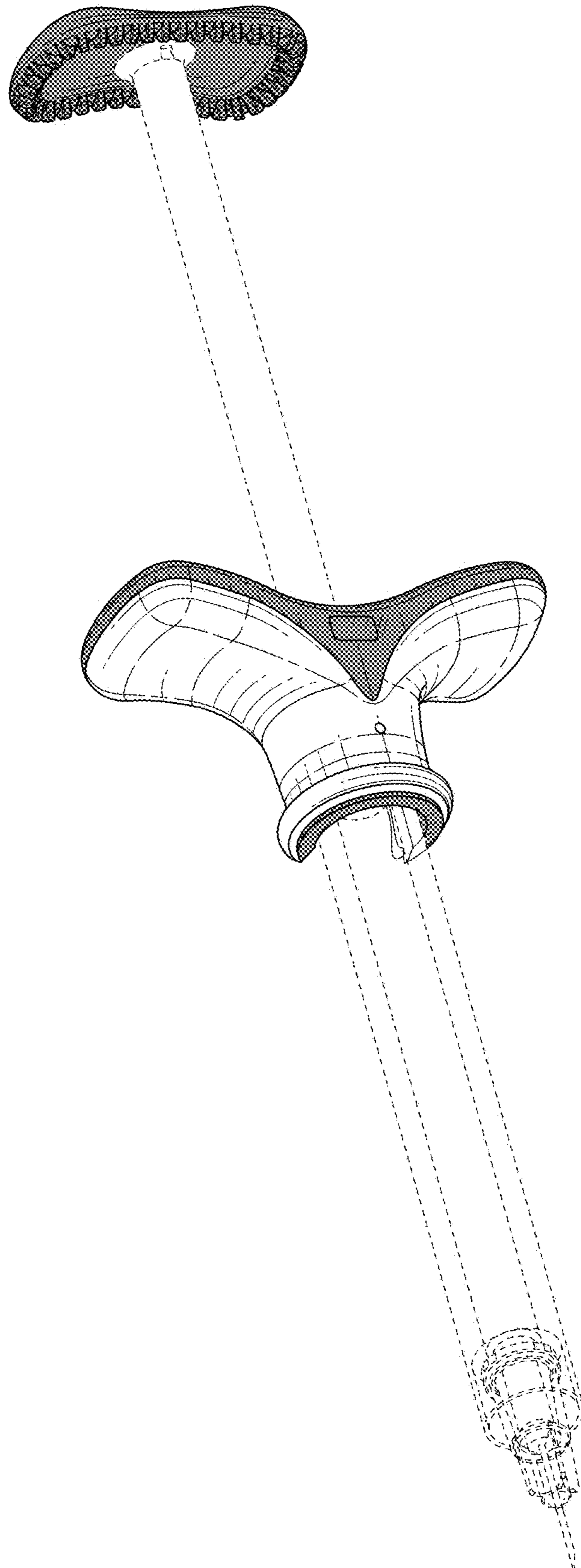

FIG. 22

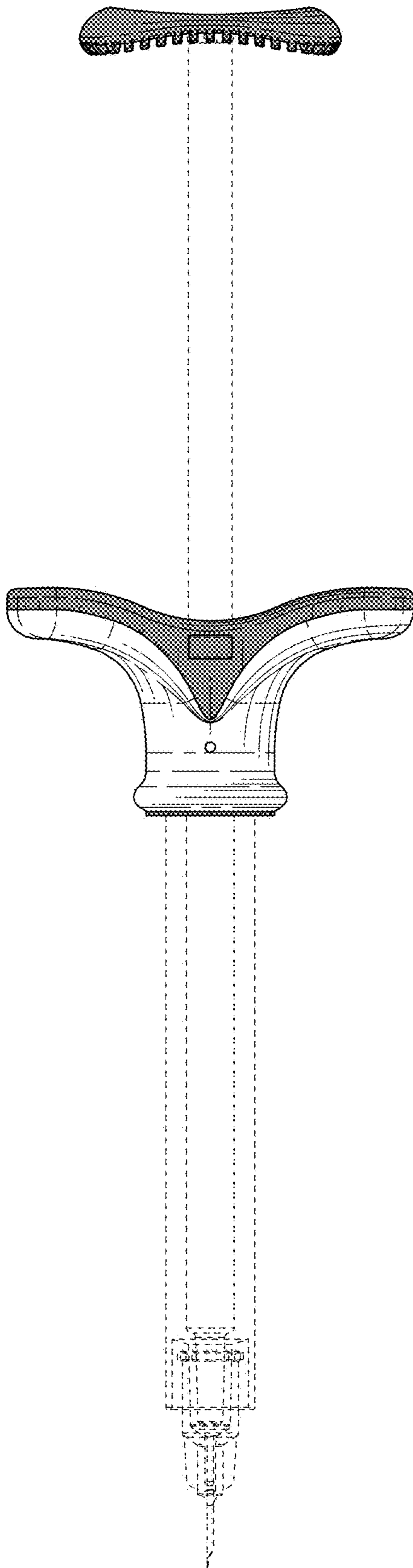

FIG. 23

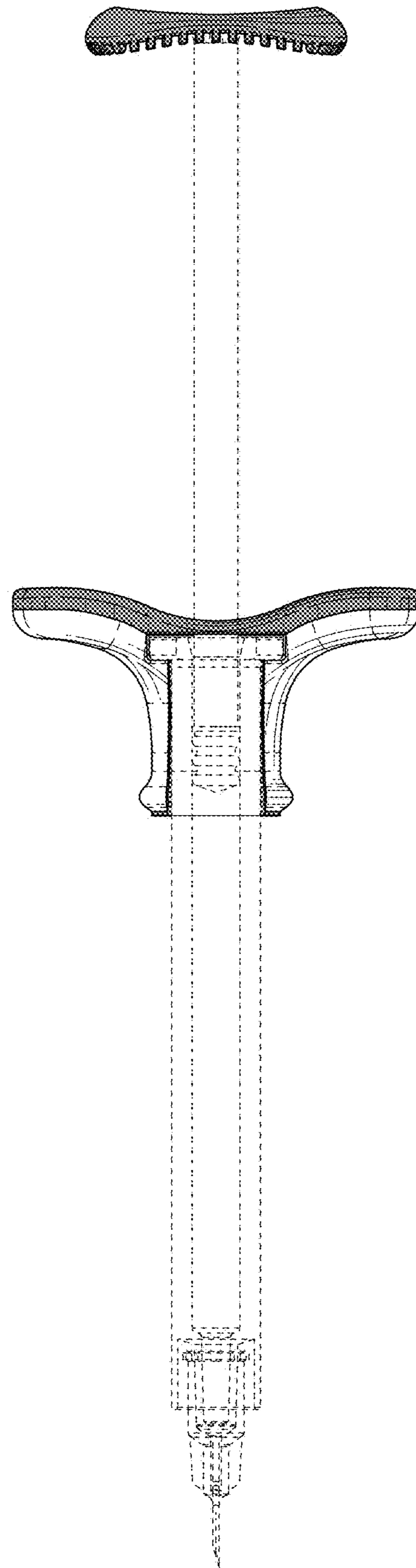

FIG. 24

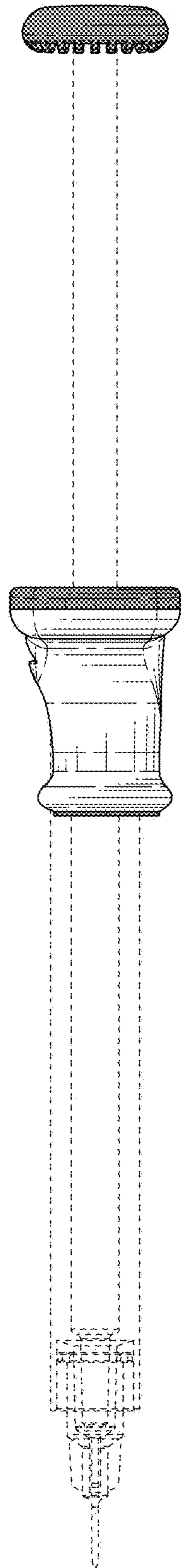

FIG. 25

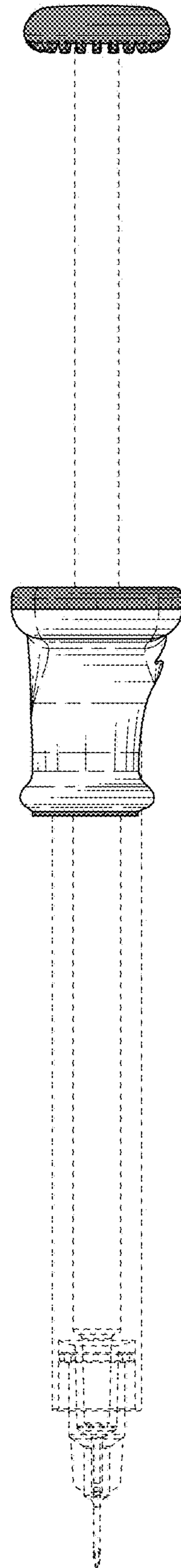

FIG. 26

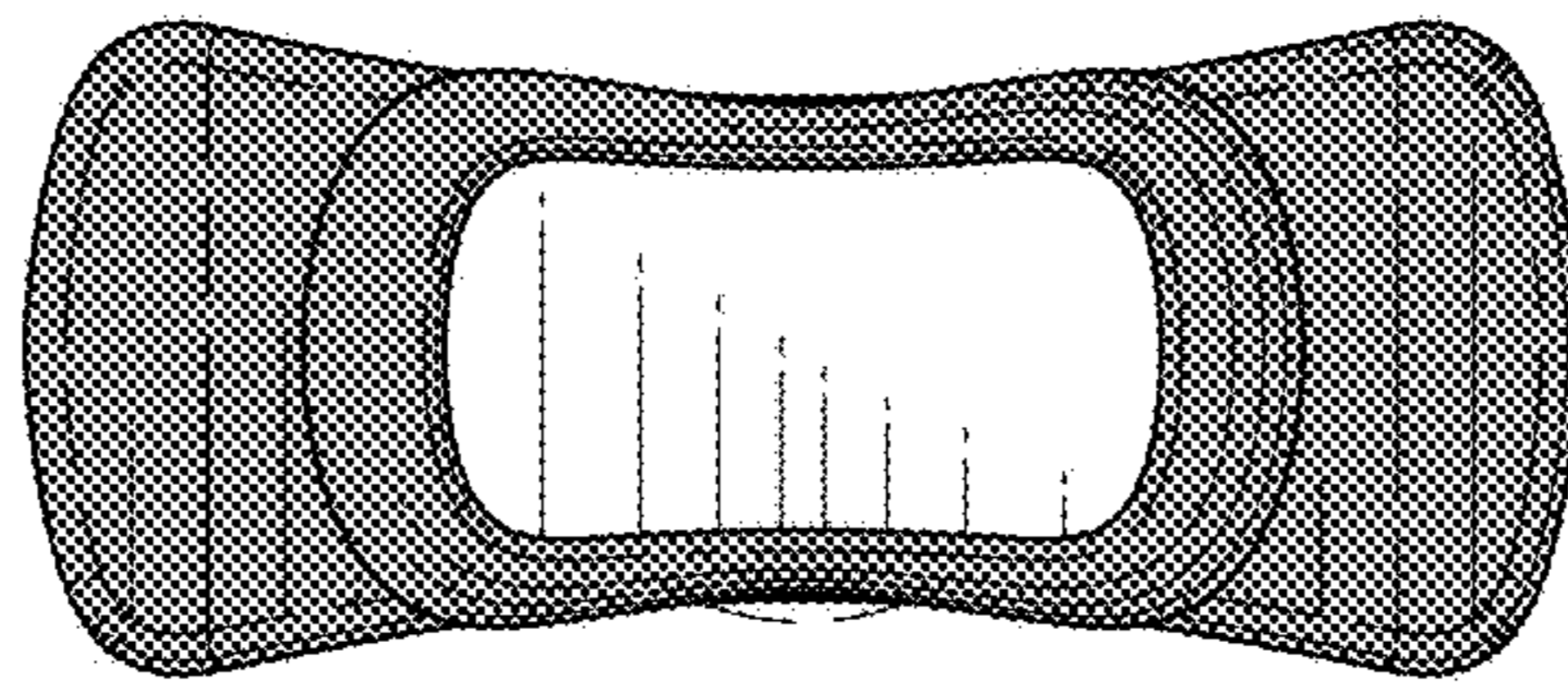

FIG. 27

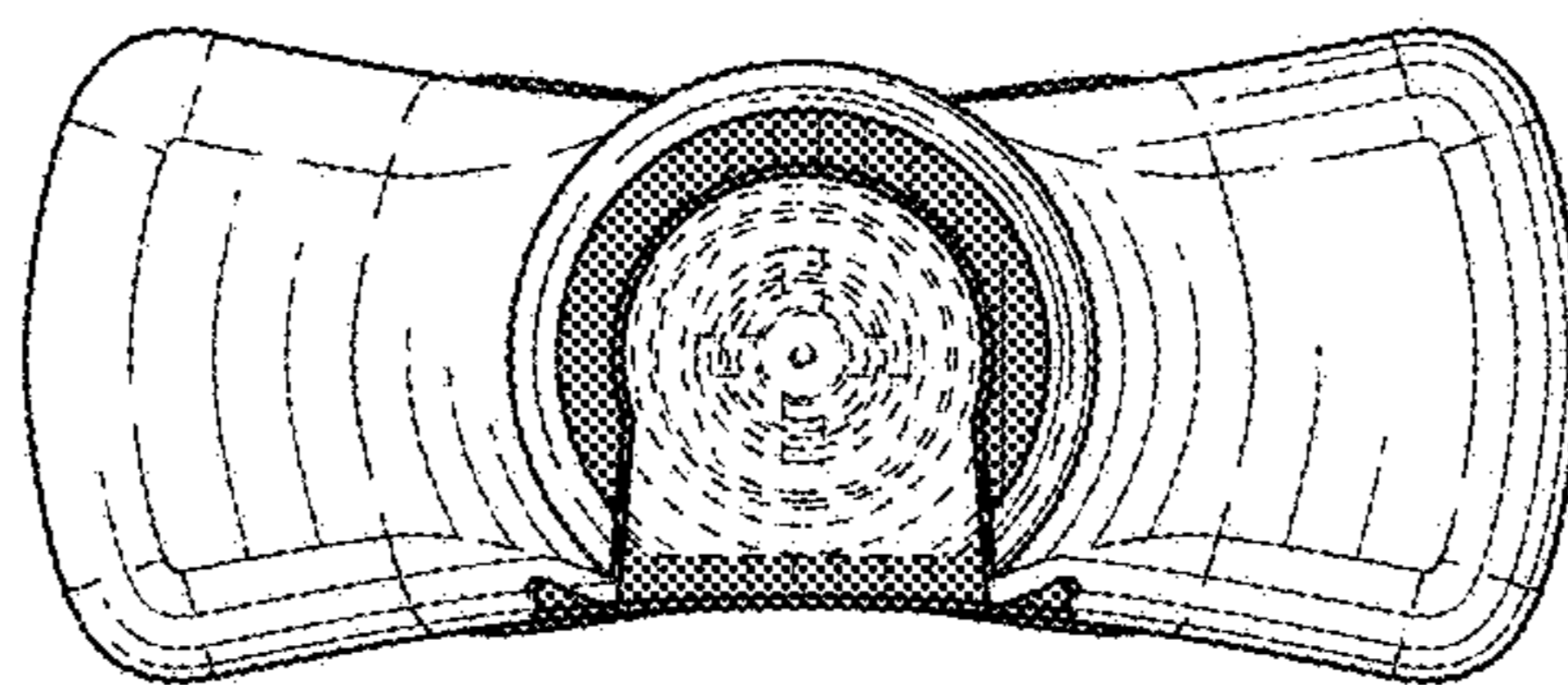

FIG. 28

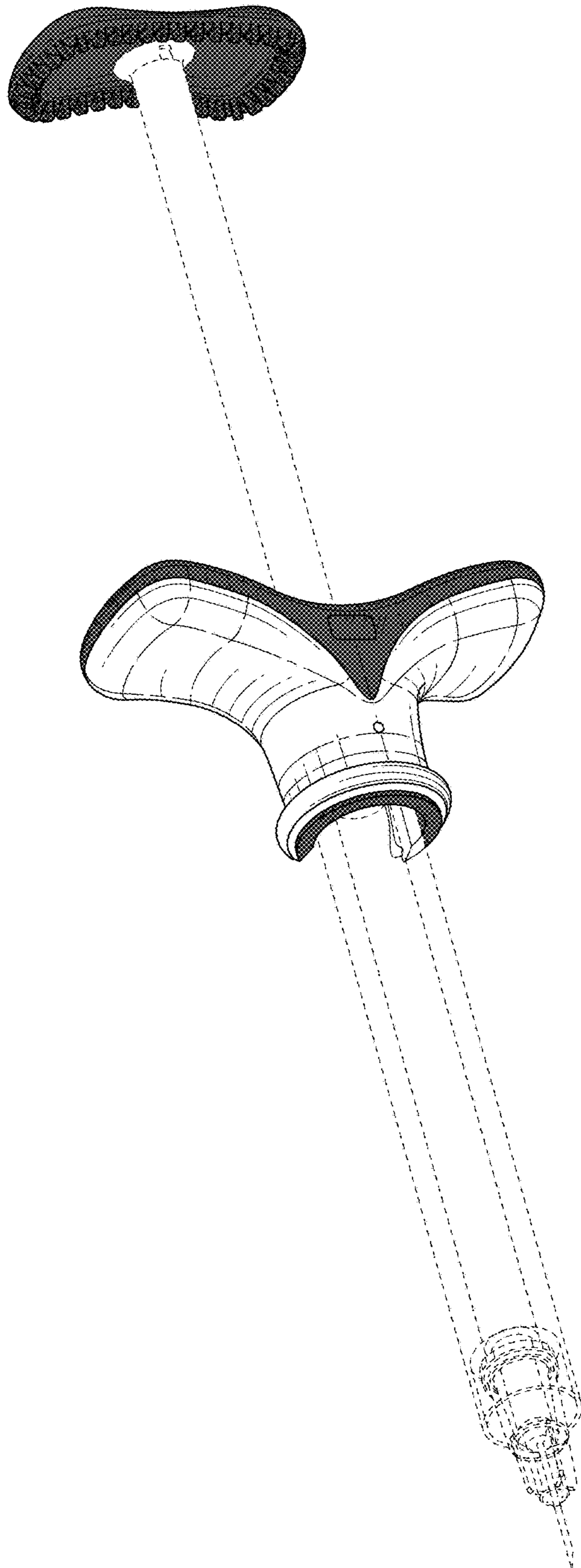

FIG. 29

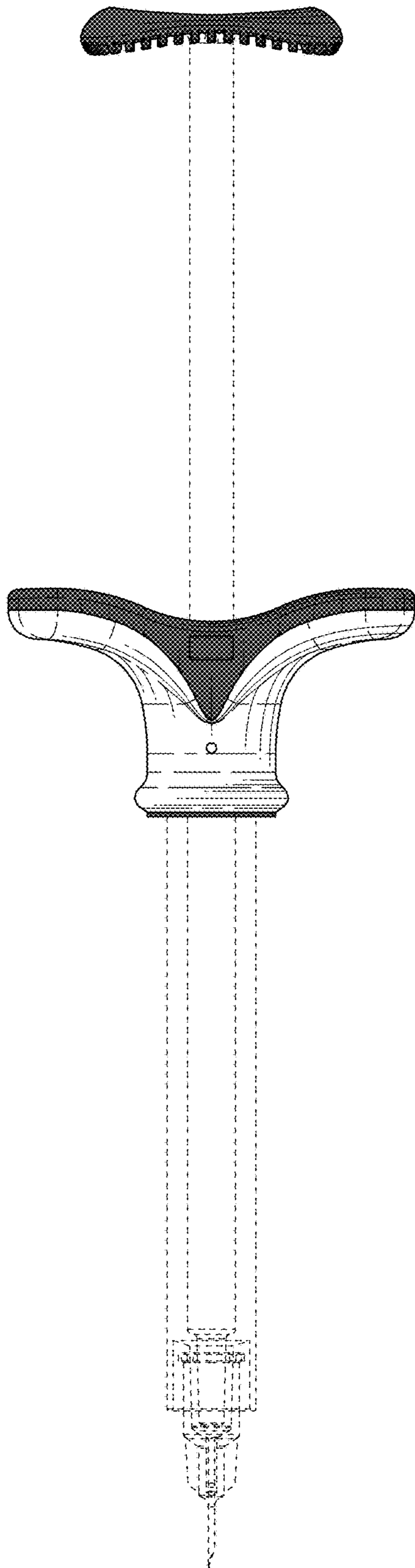

FIG. 30

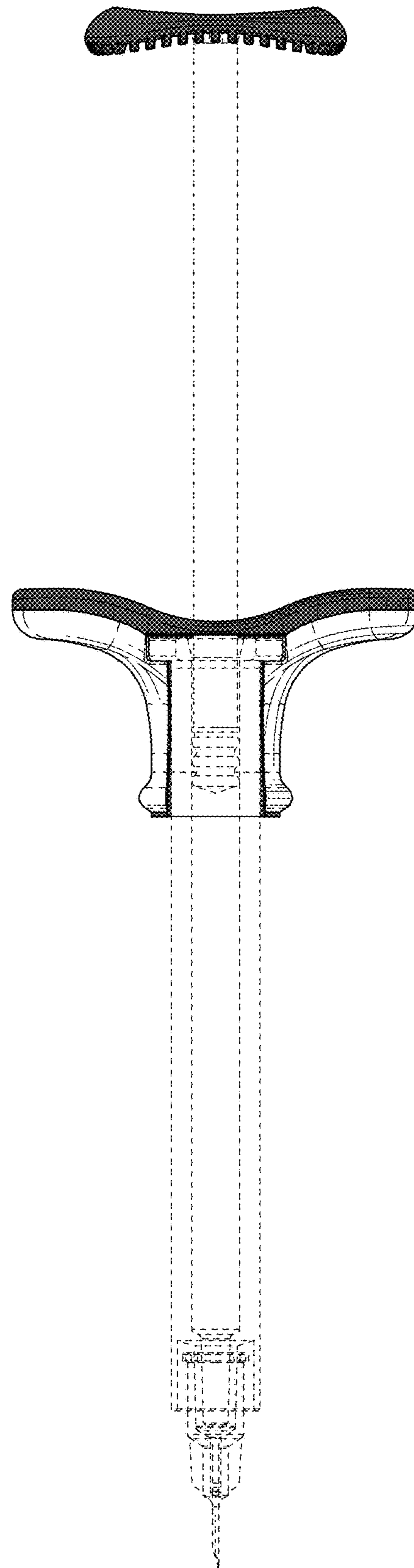

FIG. 31

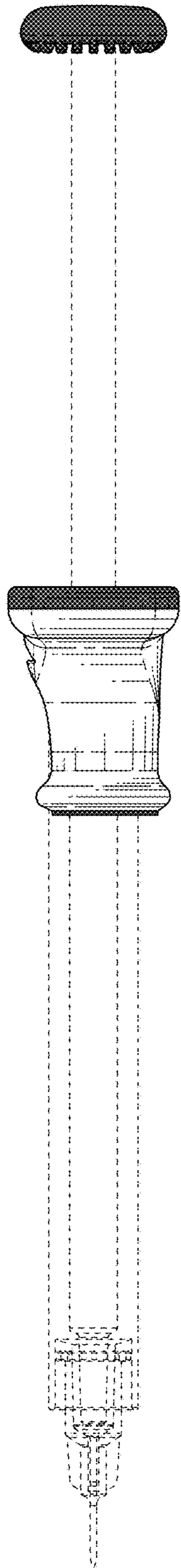

FIG. 32

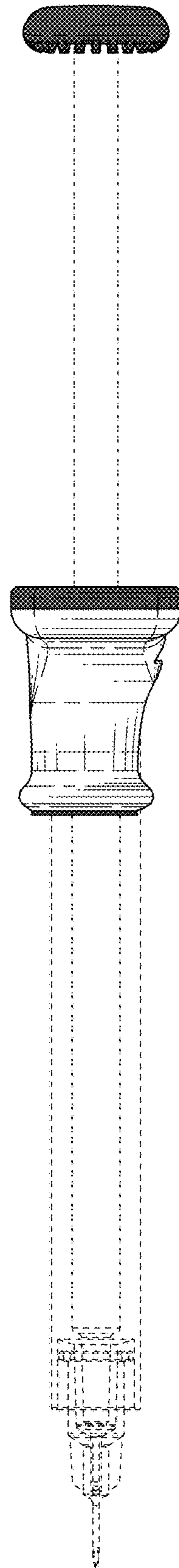

FIG. 33

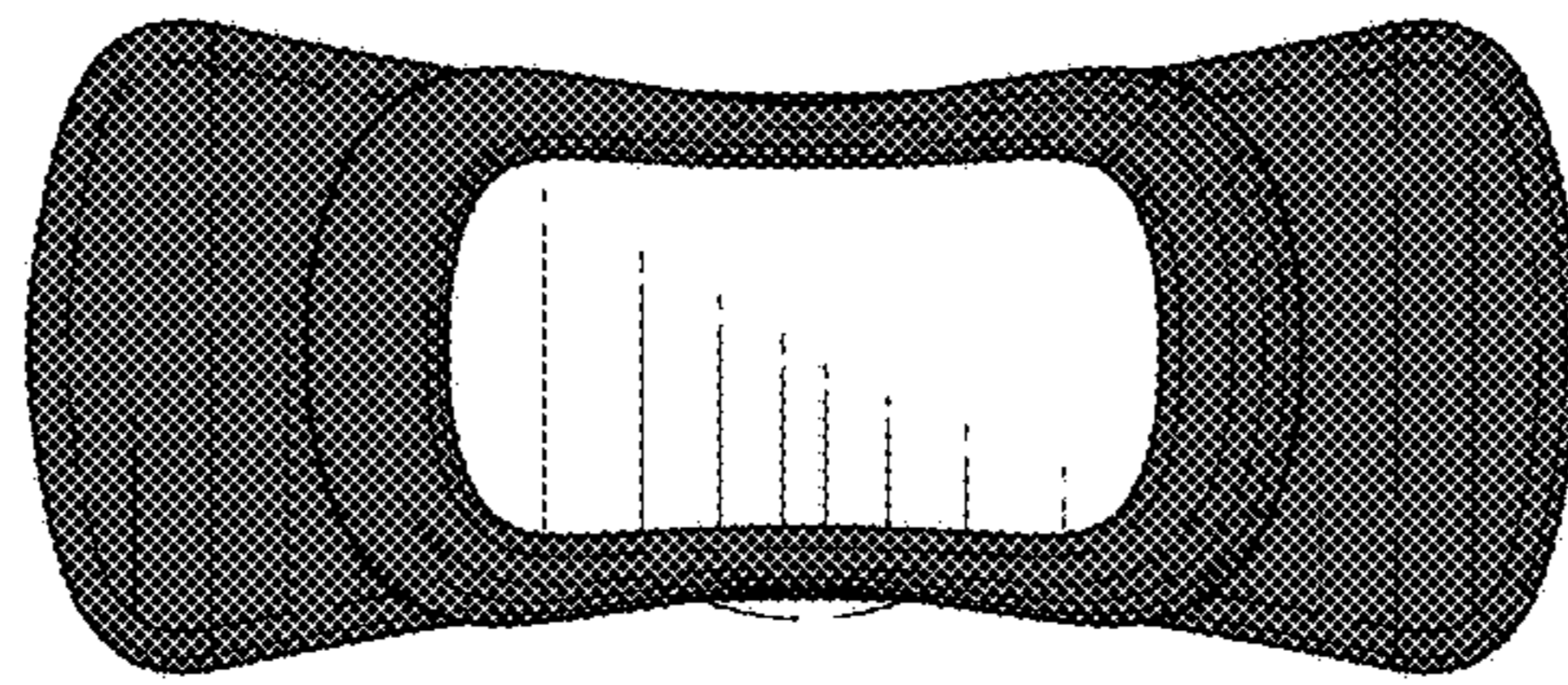

FIG. 34

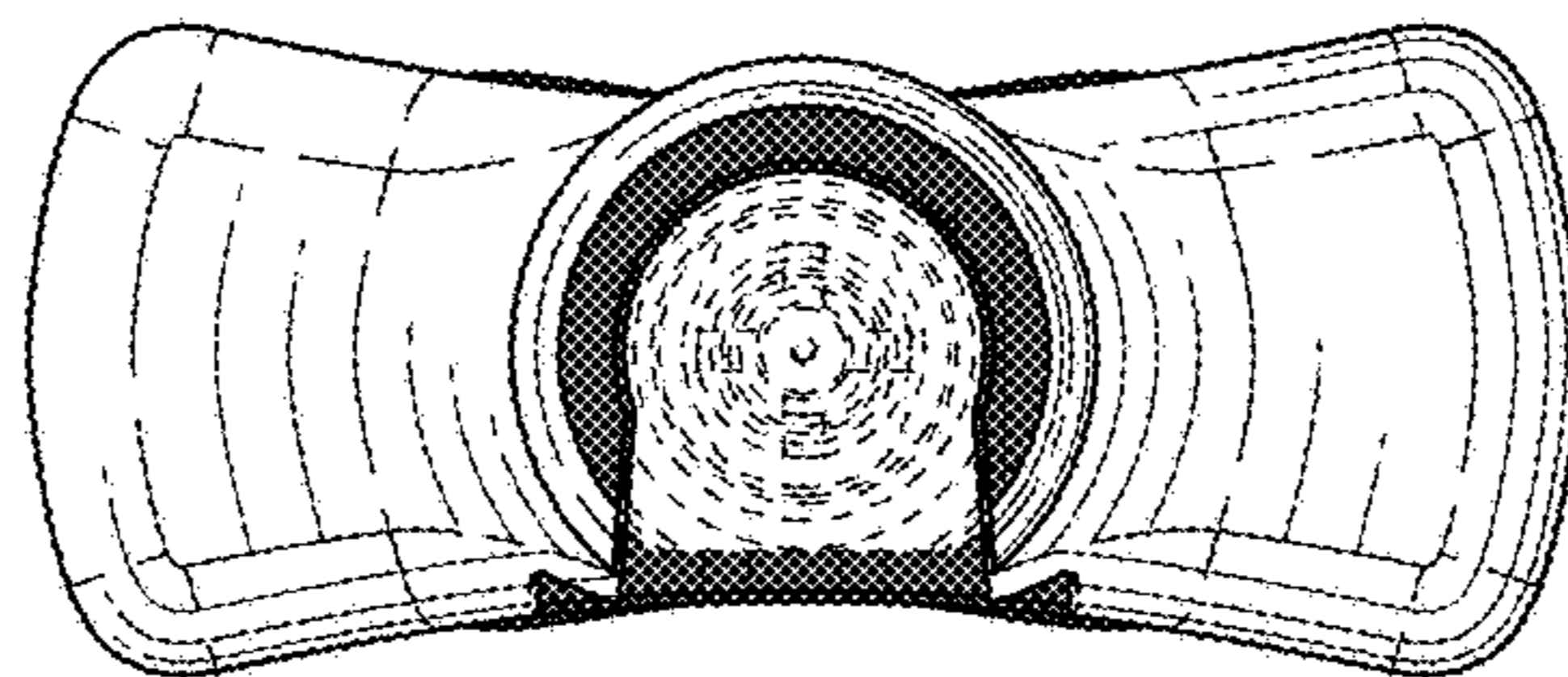

FIG. 35

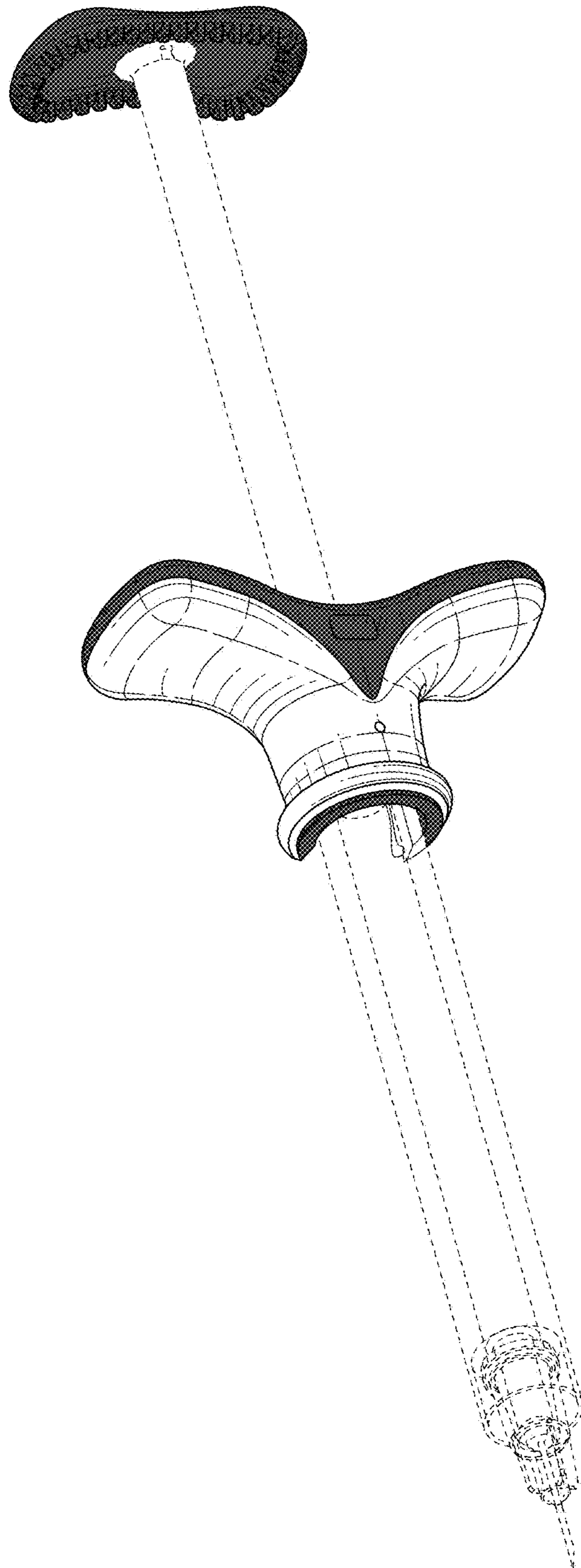

FIG. 36

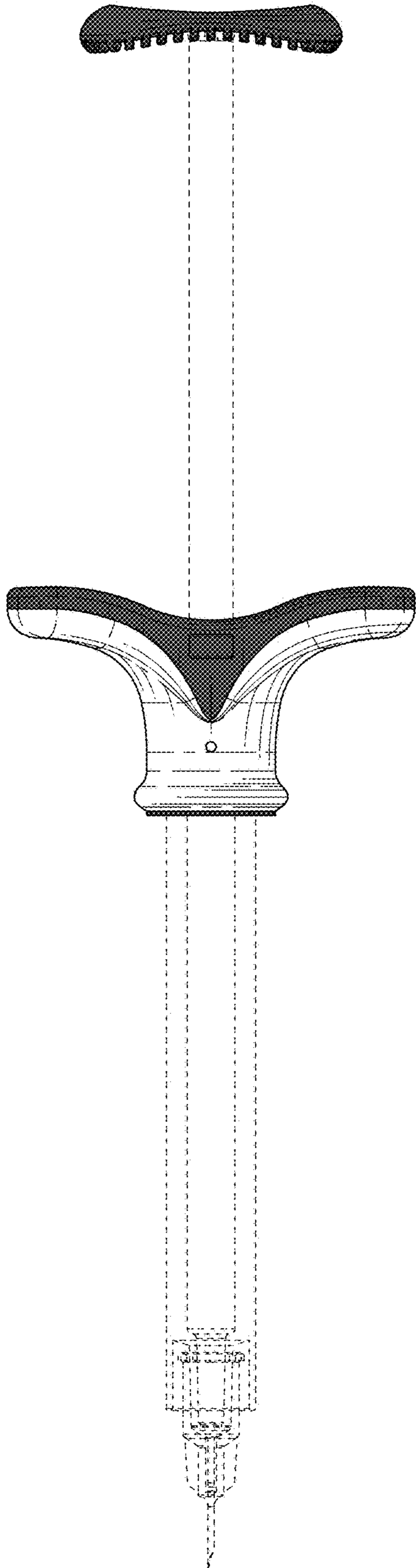

FIG. 37

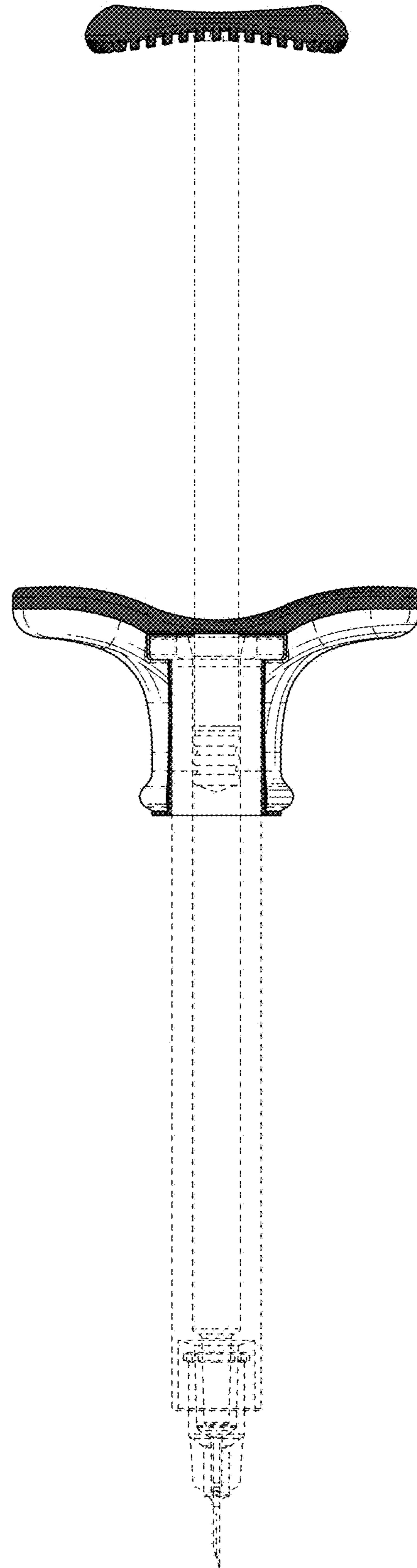

FIG. 38

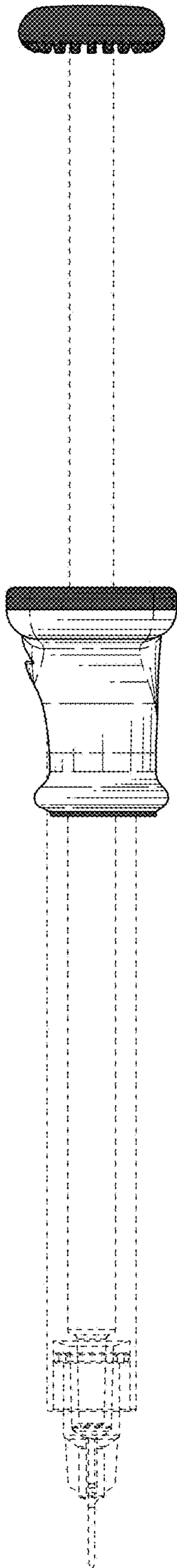

FIG. 39

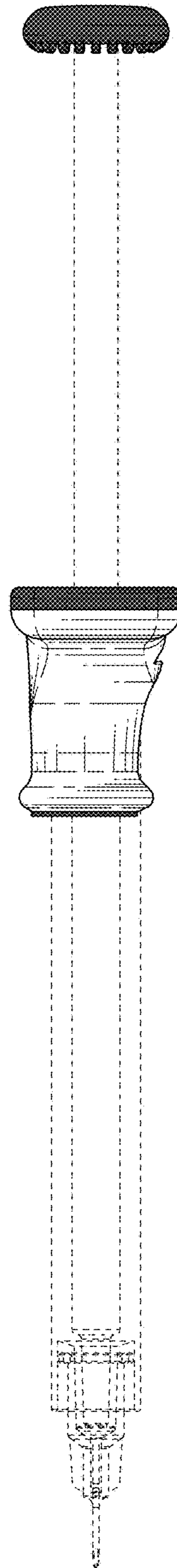

FIG. 40

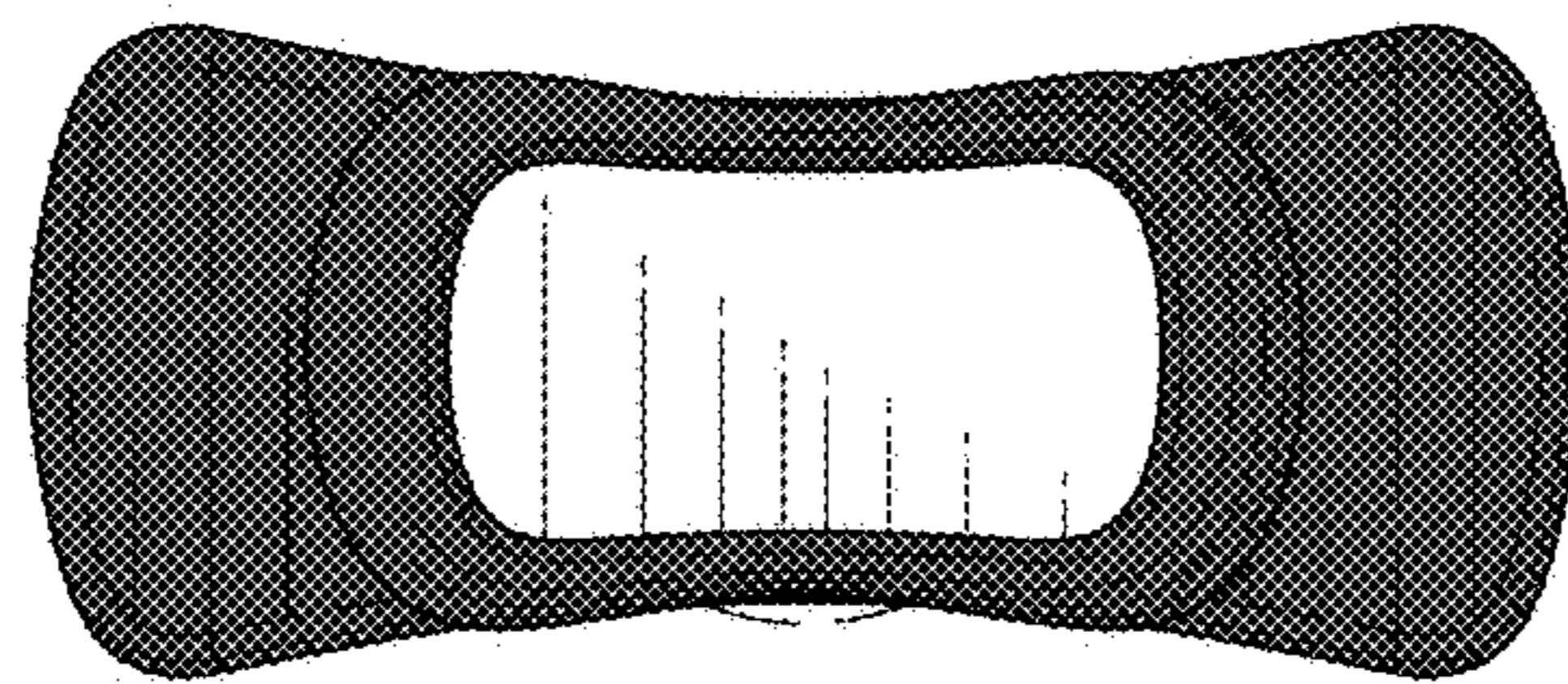

FIG. 41

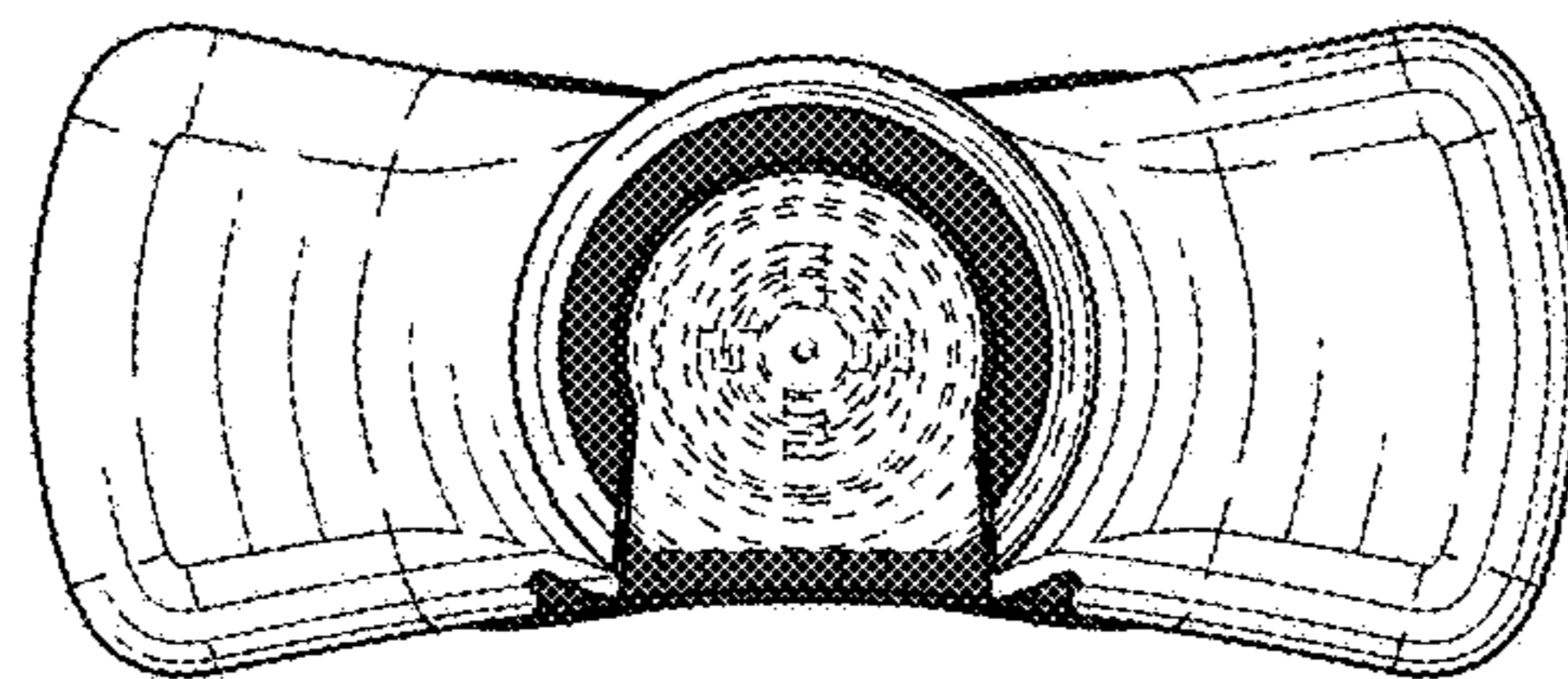

FIG. 42