



US00D867476S

(12) **United States Design Patent**
Wood et al.

(10) **Patent No.:** **US D867,476 S**

(45) **Date of Patent:** **** Nov. 19, 2019**

(54) **SWAY BAR ASSEMBLY FOR A MODEL VEHICLE**

FOREIGN PATENT DOCUMENTS

FR 2941405 A1 * 7/2010 B60G 21/0551

(71) Applicant: **TRAXXAS LP**, McKinney, TX (US)

OTHER PUBLICATIONS

(72) Inventors: **Jonathan Scott Wood**, Plano, TX (US);
Adam Cole Ewing, McKinney, TX (US); **Otto Karl Allmendinger**,
Rowlett, TX (US)

Capricorn C-803 F1 Style Rear Sway-Bar, posted at RC News, posting date Jan. 31, 2017. Site visited Apr. 12, 2019. URL: <<http://www.rcnews.net/2017/01/31/capricorn-c-803-f1-style-rear-sway-bad>> (Year: 2017).*

(Continued)

(73) Assignee: **TRAXXAS LP**, McKinney, TX (US)

Primary Examiner — Kevin K Rudzinski

Assistant Examiner — Kathleen L Jones

(**) Term: **15 Years**

(74) *Attorney, Agent, or Firm* — Daryl R. Wright; Greg Carr

(21) Appl. No.: **29/633,645**

(57) **CLAIM**

We claim the ornamental design for a sway bar assembly for a model vehicle, as shown and described.

(22) Filed: **Jan. 15, 2018**

(51) **LOC (12) Cl.** **21-01**

(52) **U.S. Cl.**
USPC **D21/561**; D12/159

DESCRIPTION

(58) **Field of Classification Search**
USPC D21/495, 561; D12/159–160
CPC B60G 2200/1322; B60G 2200/14; B60G 2200/142; B60G 2200/1422; B60G 2200/1424; B60G 2200/1442; B60G 2200/156; B60G 2200/182; B60G 2200/22; B60G 2200/315
See application file for complete search history.

FIG. 1 is an upper, right, front perspective view of a sway bar assembly for a model vehicle;
FIG. 2 is front elevation view thereof;
FIG. 3 is a rear elevation view thereof;
FIG. 4 is a left side elevation view thereof;
FIG. 5 is a right side elevation view thereof;
FIG. 6 is a top plan view thereof;
FIG. 7 is a bottom plan view thereof;
FIG. 8 is an upper, left, rear perspective view; and,
FIG. 9 is an upper, left, front perspective view thereof showing the sway bar assembly for a model vehicle within a broken line environment of use.

In the drawings, the broken line showing of features of the sway bar assembly for a model vehicle illustrate portions of the sway bar assembly for a model vehicle that form no part of the claimed design; whereas, the broken lines showing of a model vehicle in FIG. 9 are included to illustrate environmental structure and also form no part of the claimed design.

(56) **References Cited**

U.S. PATENT DOCUMENTS

D34,632 S * 6/1901 Warner D12/159
D250,465 S * 12/1978 Morrison D12/159
4,600,216 A * 7/1986 Burkholder B62D 9/02
180/210
D289,277 S * 4/1987 Horberg D12/160
D330,529 S * 10/1992 Yun D12/107
D330,530 S * 10/1992 Yun D12/107

(Continued)

1 Claim, 7 Drawing Sheets

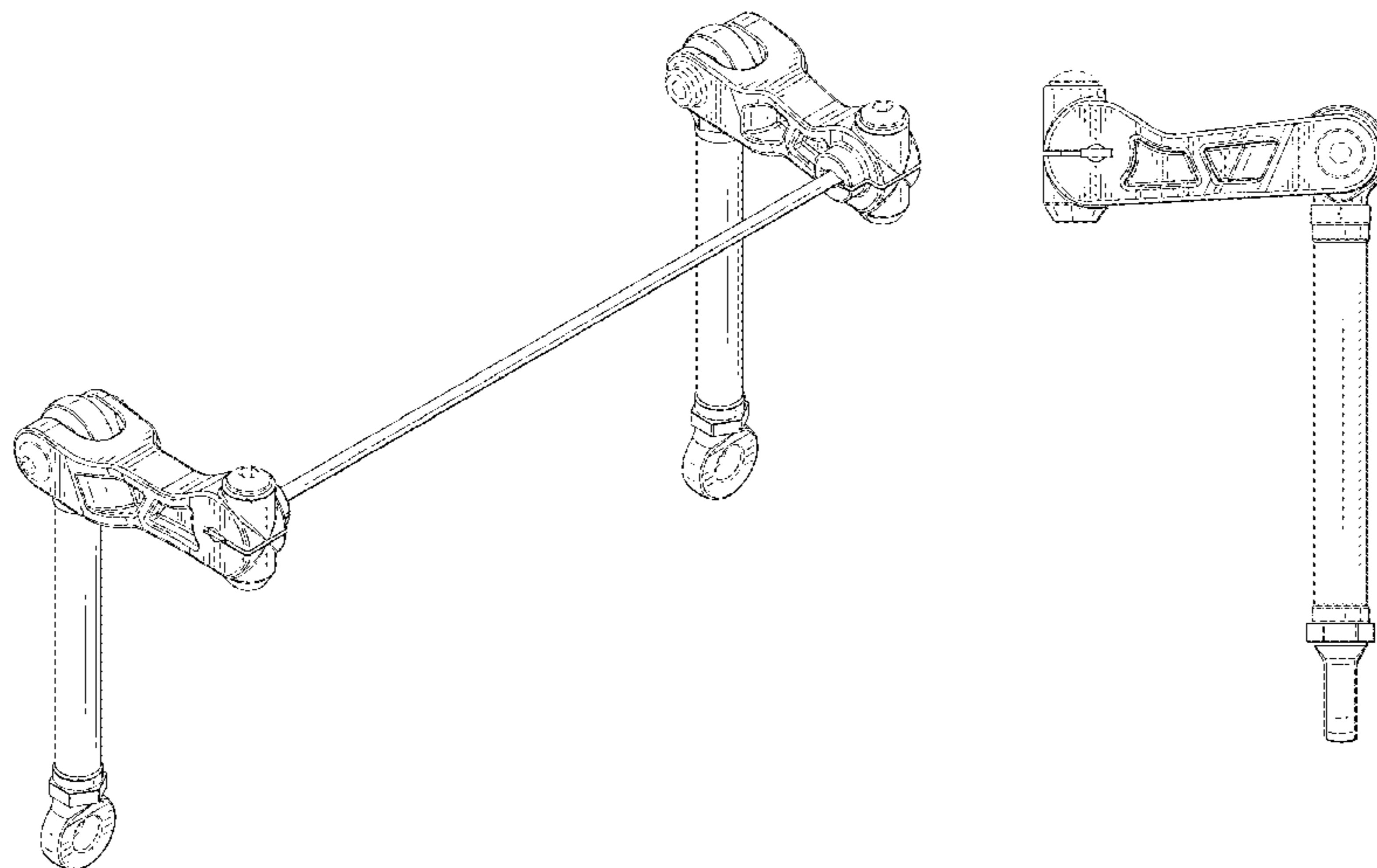

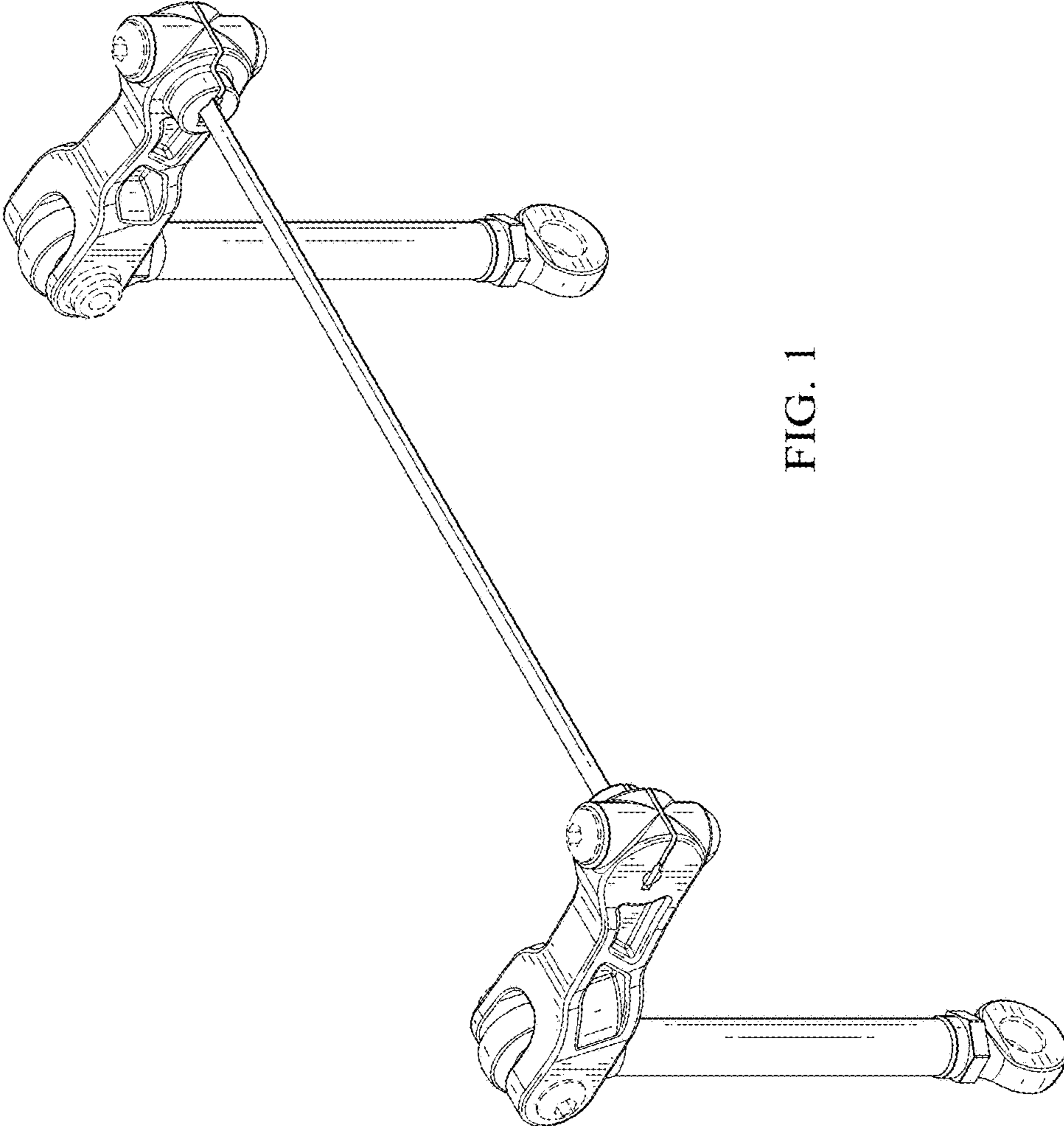

FIG. 1

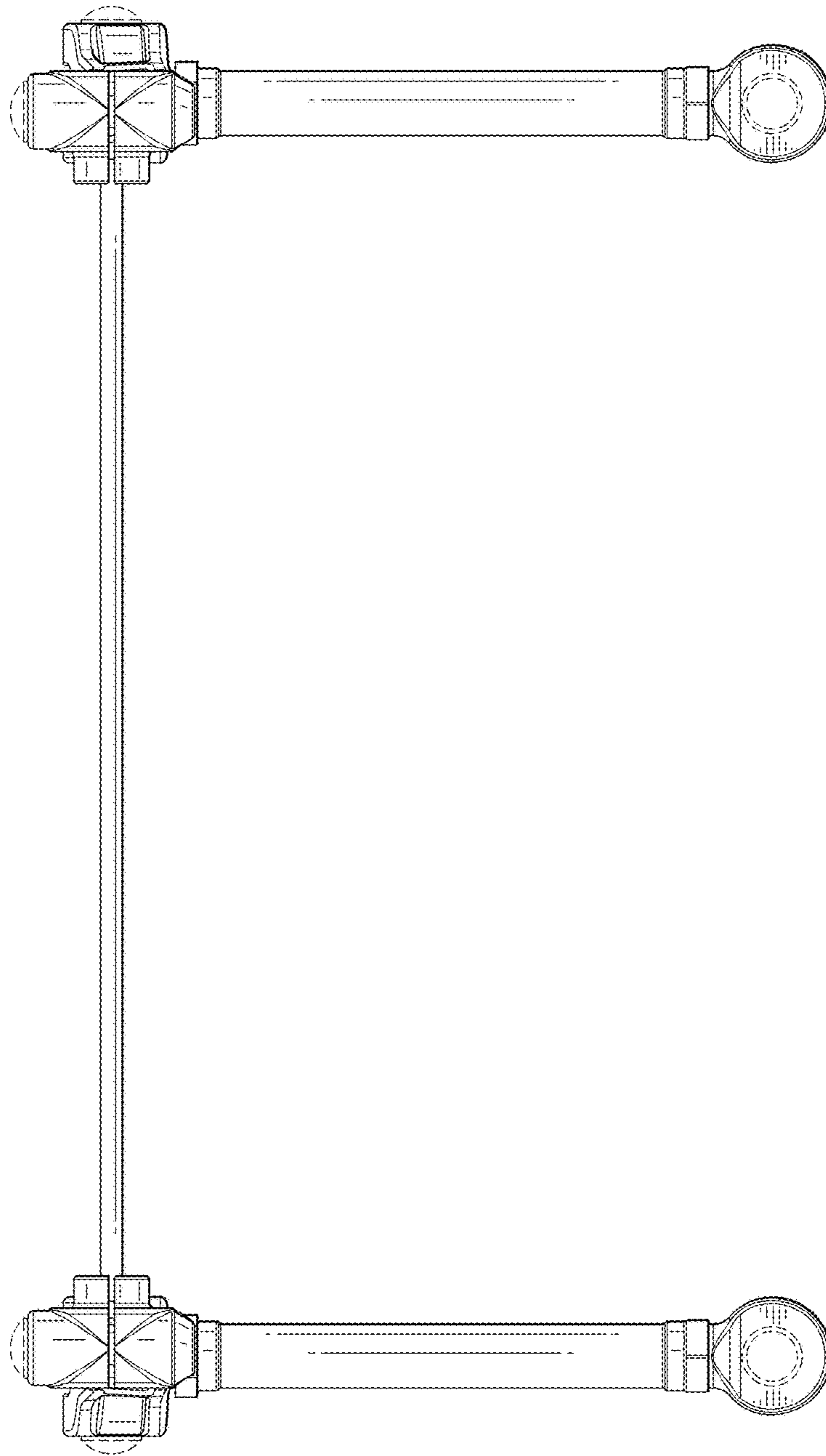

FIG. 2

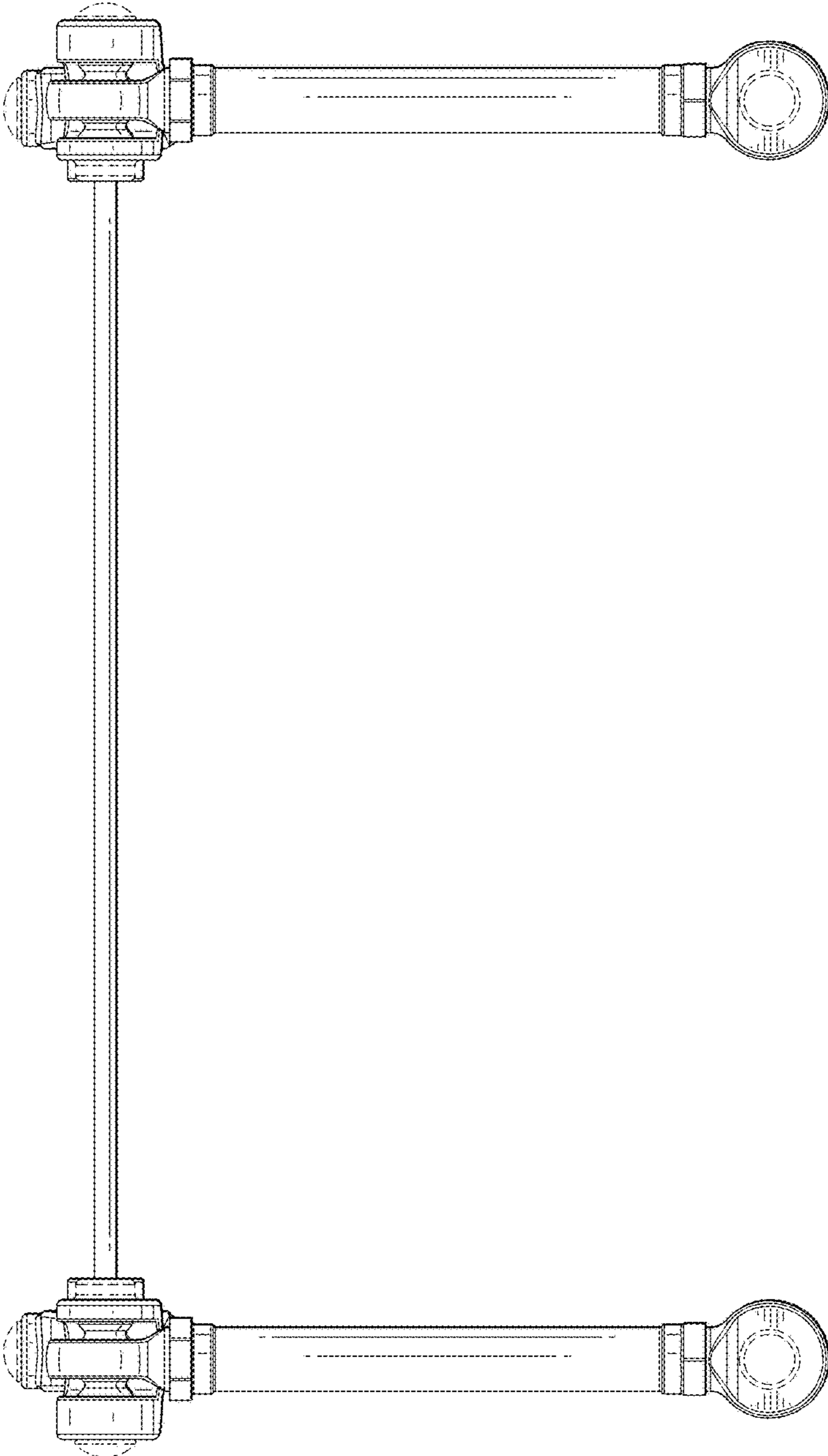

FIG. 3

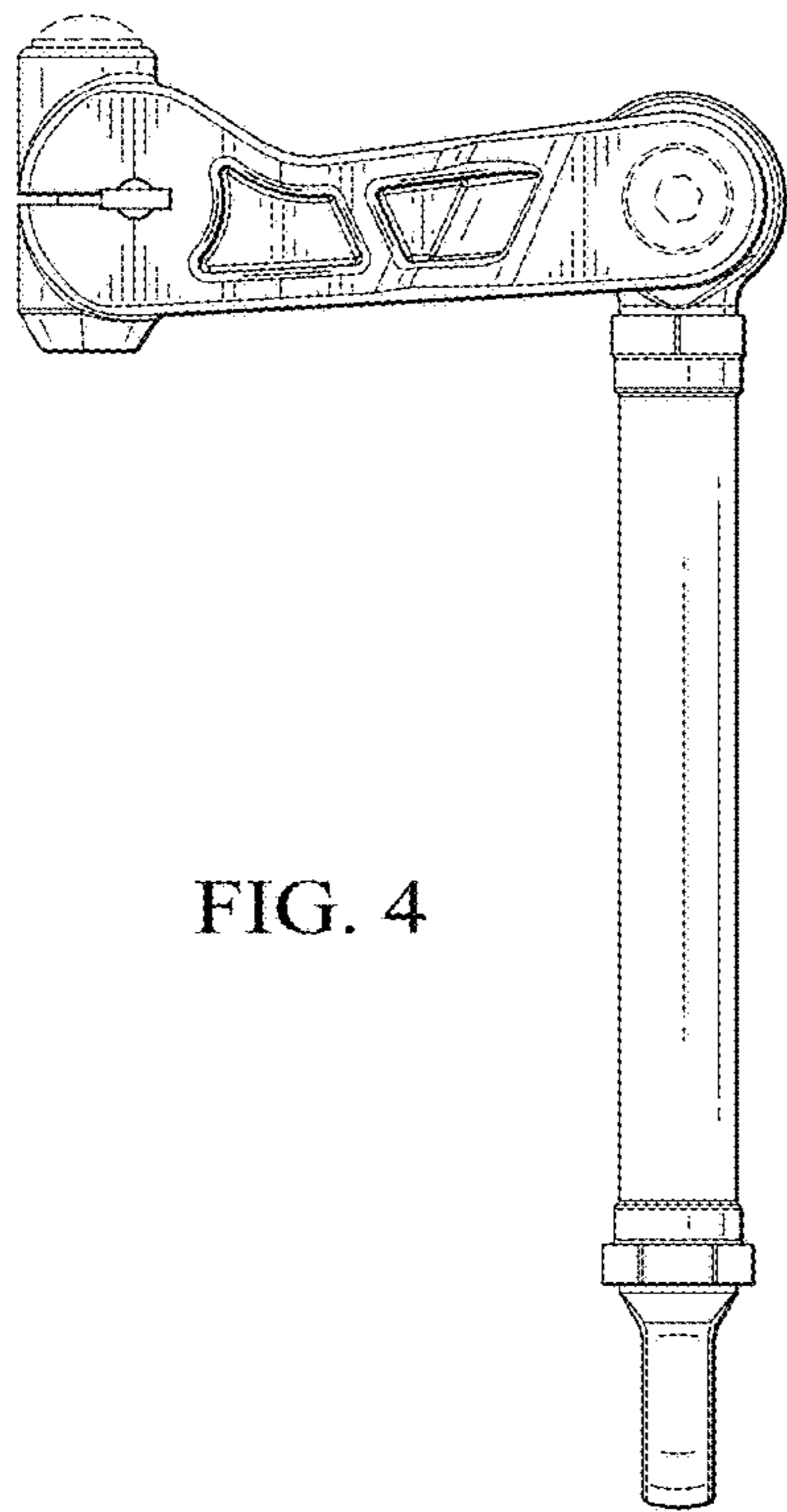

FIG. 4

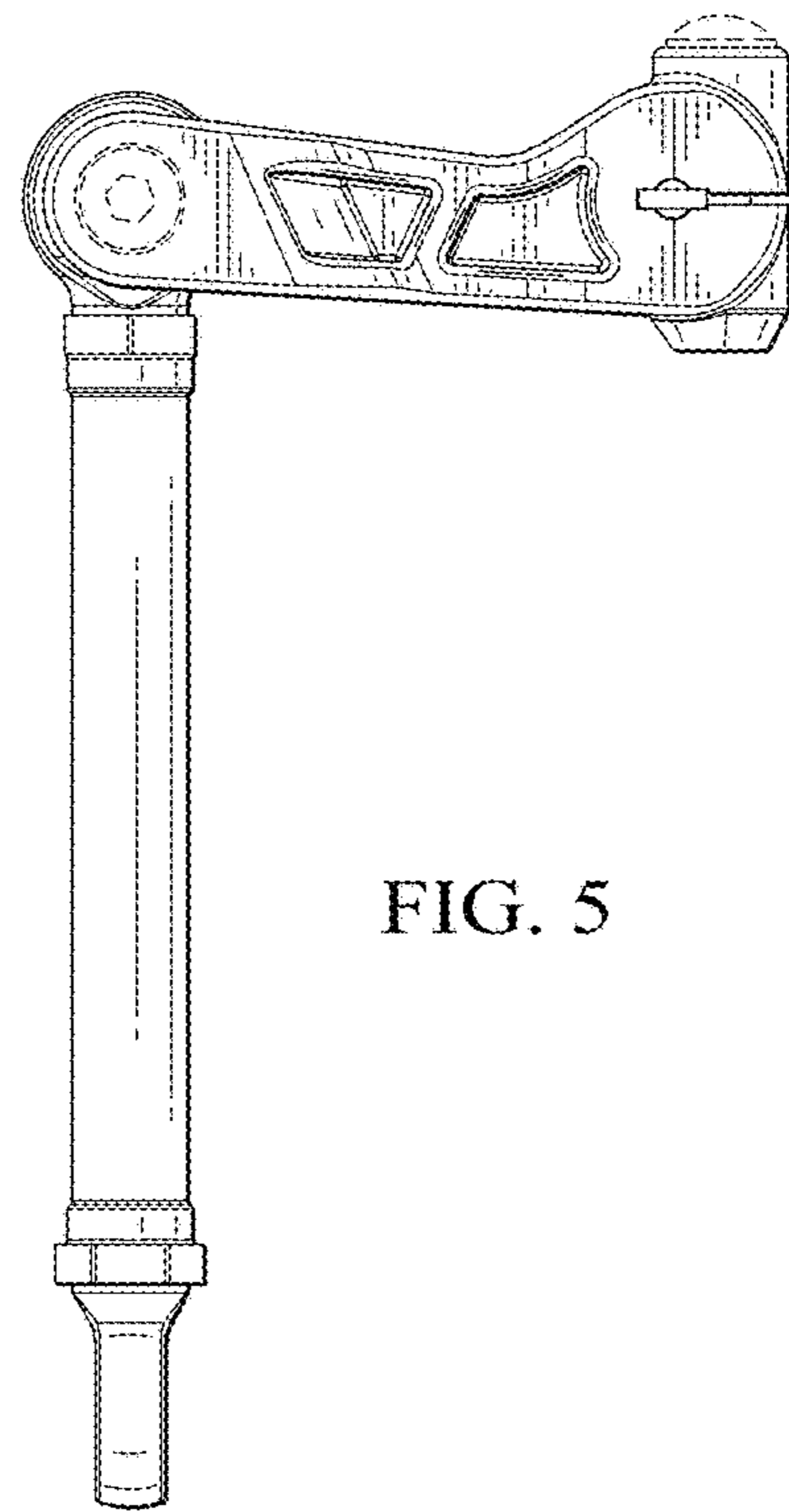
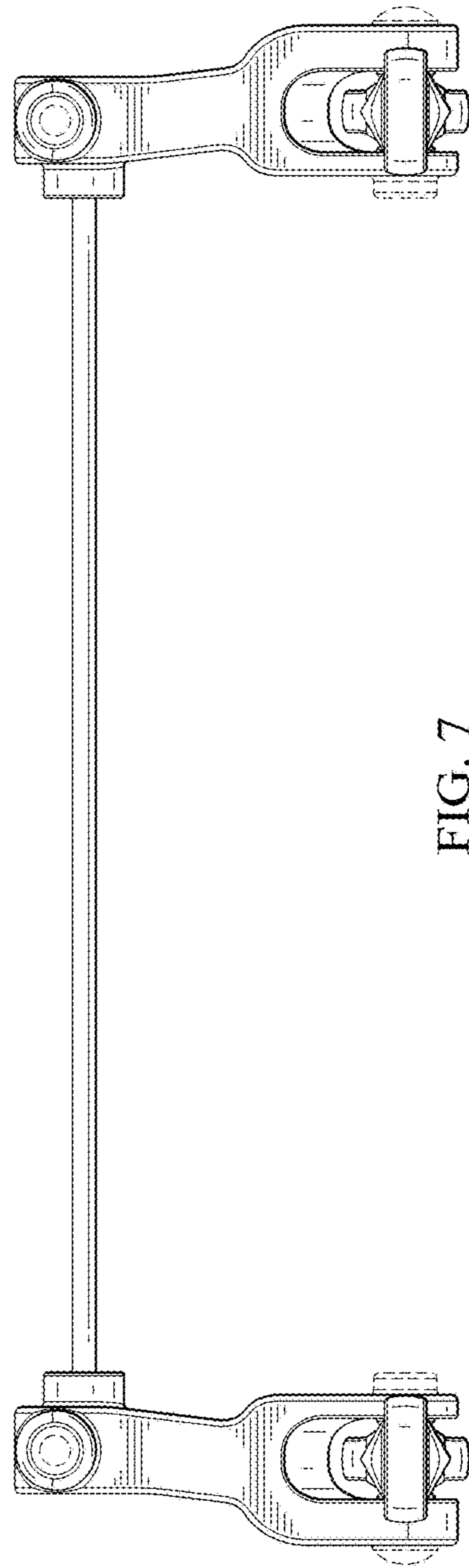
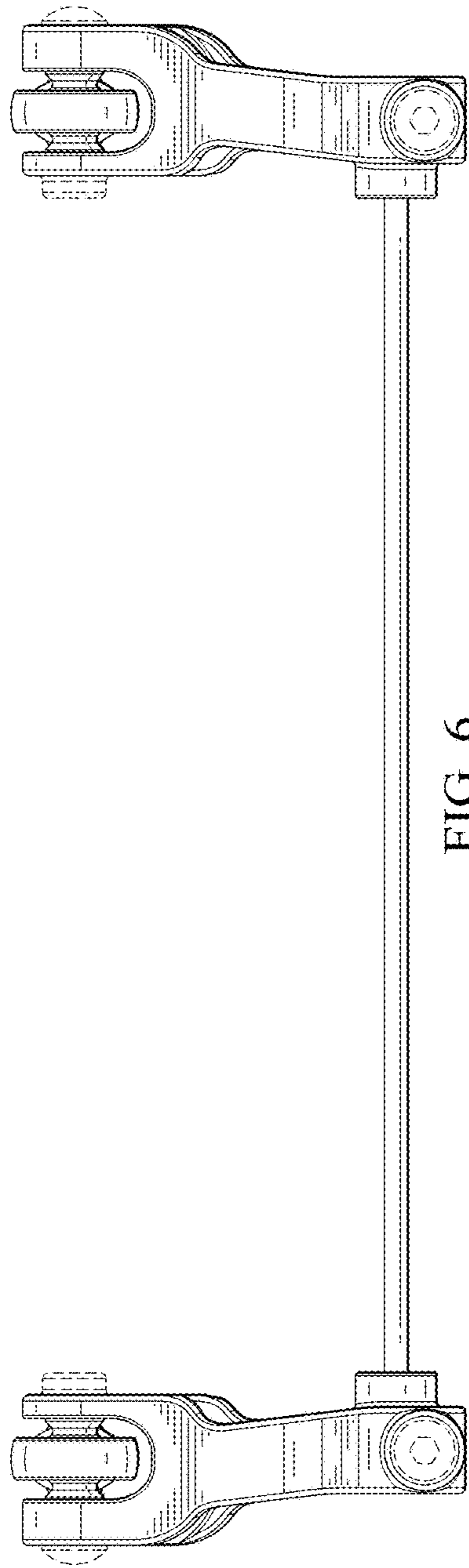

FIG. 5



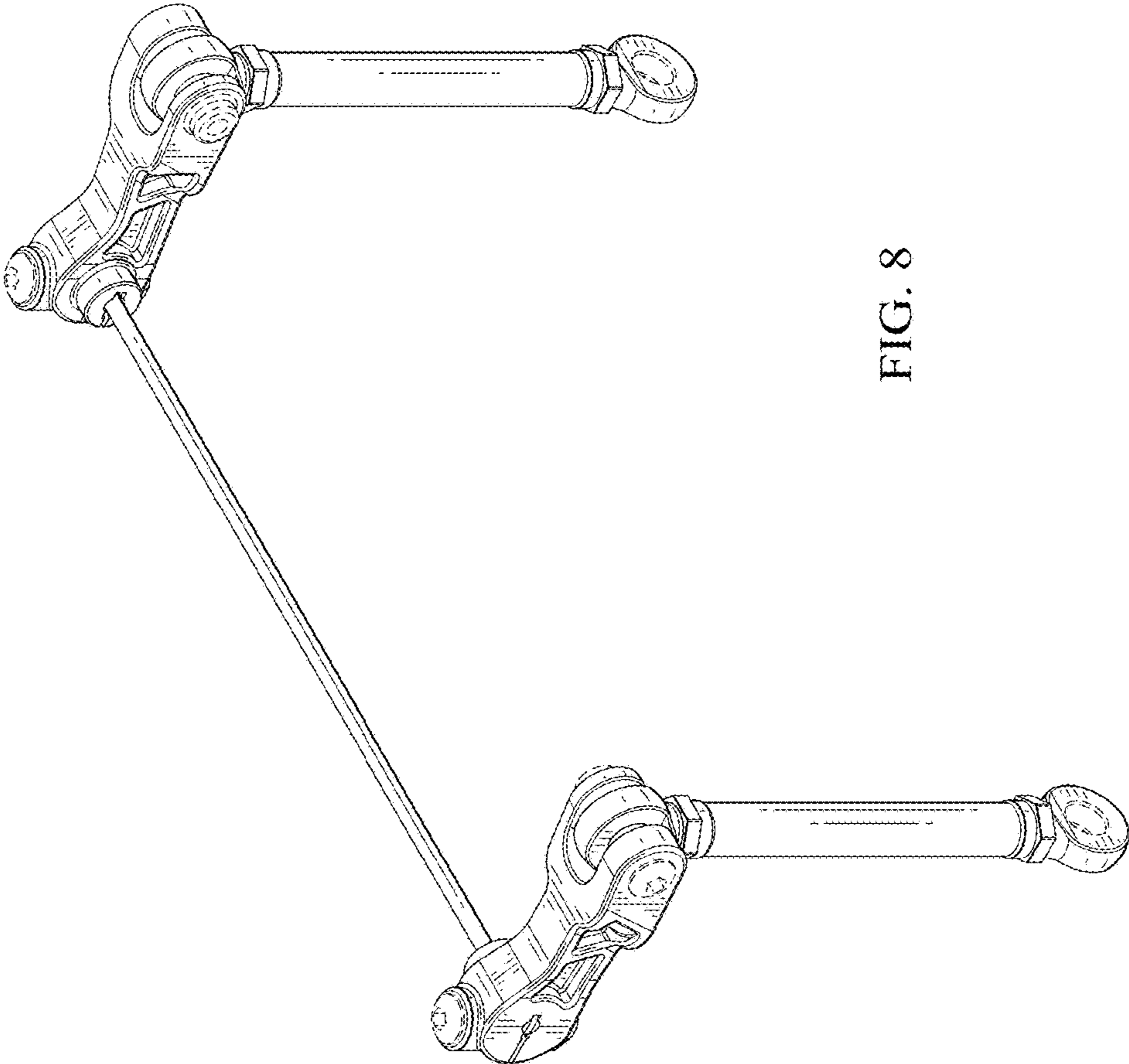

FIG. 8

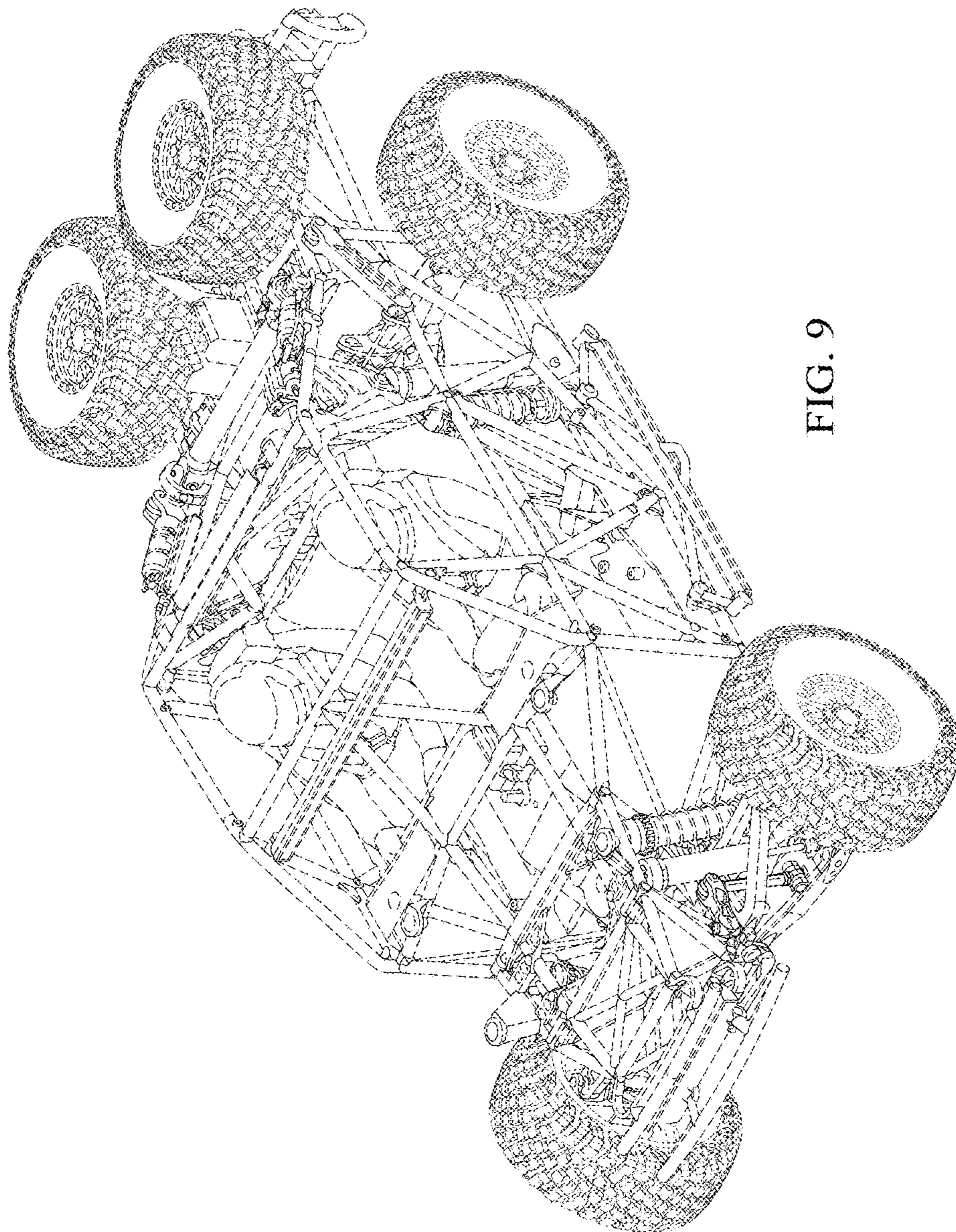

FIG. 9