

US00D867403S

(12) **United States Design Patent** (10) **Patent No.:** **US D867,403 S**
Ryan et al. (45) **Date of Patent:** **** Nov. 19, 2019**

(54) **BUMPER**

(71) Applicant: **THE RAYMOND CORPORATION**,
Greene, NY (US)

(72) Inventors: **Howard Scott Ryan**, Skaneateles, NY
(US); **Gregory W. Smiley**, Greene, NY
(US); **Frank Witkowski**, Syracuse, NY
(US)

(73) Assignee: **The Raymond Corporation**, Greene,
NY (US)

(**) Term: **15 Years**

(21) Appl. No.: **29/682,058**

(22) Filed: **Mar. 1, 2019**

Related U.S. Application Data

(62) Division of application No. 29/560,205, filed on Apr.
4, 2016, now Pat. No. Des. 846,599.

(51) **LOC (12) Cl.** **15-03**

(52) **U.S. Cl.**
USPC **D15/28; D15/31**

(58) **Field of Classification Search**
USPC D15/10, 22-26, 33, 28, 31; D21/431;
37/403, 409, 442, 443; 180/89.1, 89.12,
(Continued)

(56) **References Cited**

U.S. PATENT DOCUMENTS

D578,274 S 10/2008 Tokach
D611,505 S 3/2010 Loew
(Continued)

Primary Examiner — Mark A Goodwin

(74) *Attorney, Agent, or Firm* — Quarles & Brady LLP

(57) **CLAIM**

The ornamental design for a bumper, as shown and described.

DESCRIPTION

FIG. 1 is an isometric view of a top, left, and front side of an ornamental design for a bumper;
FIG. 2 is an isometric view of a bottom, right, and rear side of the bumper of FIG. 1;
FIG. 3 is a front elevational view of the bumper of FIG. 1;
FIG. 4 is a rear elevational view of the bumper of FIG. 1;
FIG. 5 is a right side elevational view of the bumper of FIG. 1;
FIG. 6 is a left side elevational view of the bumper of FIG. 1;
FIG. 7 is a top plan view of the bumper of FIG. 1;
FIG. 8 is a bottom plan view of the bumper of FIG. 1;
FIG. 9 is an isometric view of a top, left, and front side of the bumper of FIG. 1 with environmental portions removed for clarity;
FIG. 10 is an isometric view of a bottom, right, and front side of the bumper of FIG. 9;
FIG. 11 is a front elevational view of the bumper of FIG. 9;
FIG. 12 is a rear elevational view of the bumper of FIG. 9;
FIG. 13 is a right side elevational view of the bumper of FIG. 9;
FIG. 14 is a left side elevational view of the bumper of FIG. 9;
FIG. 15 is a top plan view of the bumper of FIG. 9; and,
FIG. 16 is a bottom plan view of the bumper of FIG. 9.
The dash-dash-dash broken lines are included for the purpose of illustrating portions of the bumper that form no part of the claimed design. The appendix depicts additional embodiments of the claimed ornamental design for a bumper.

1 Claim, 16 Drawing Sheets

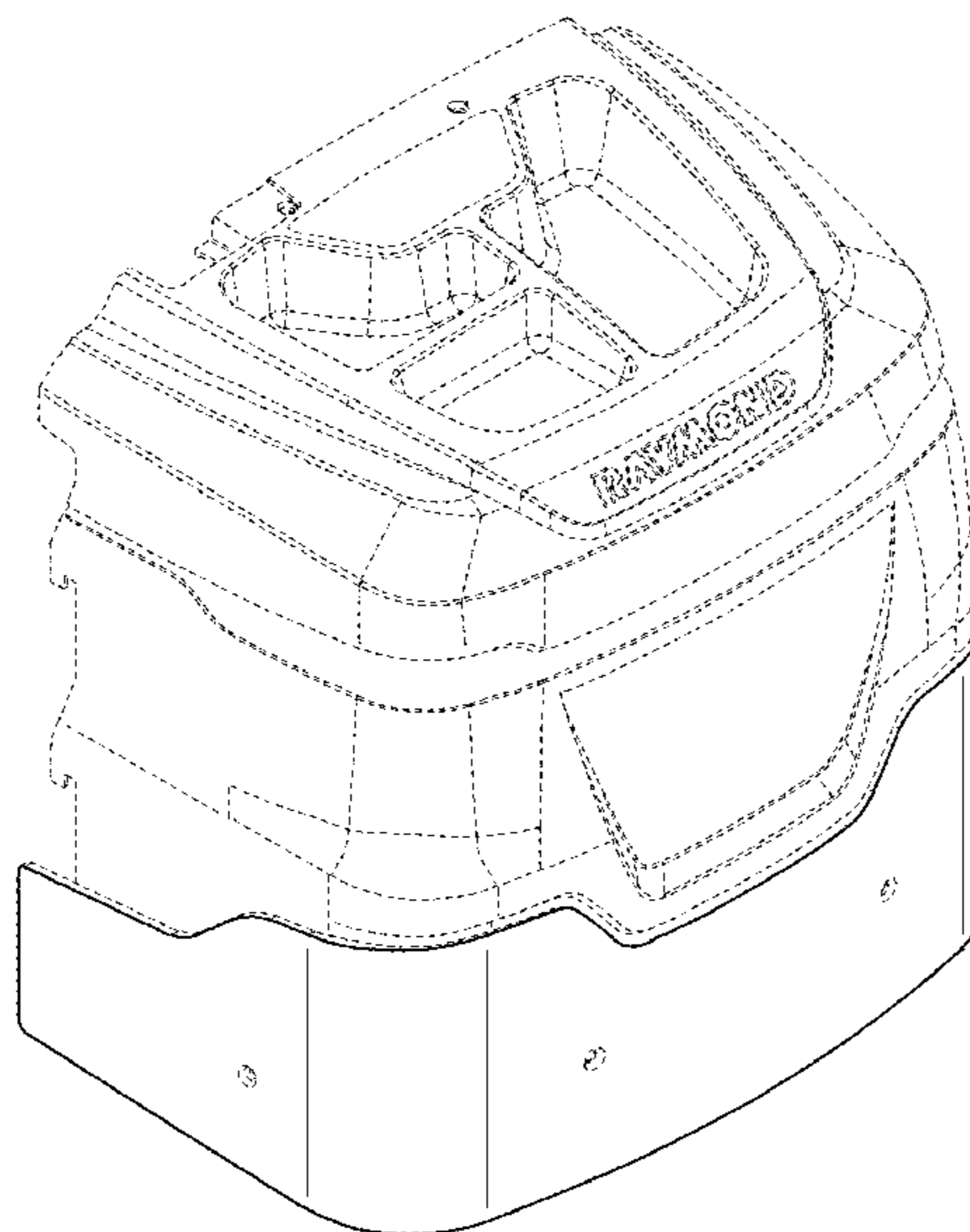

(58) **Field of Classification Search**

USPC 180/89.13; 296/190.03; 414/685, 694,
414/722, 724

CPC E02F 9/0841; E02F 3/3411; E02F 3/76;
E02F 3/34; E02F 3/00; E02F 7/00; B62D
21/186; B62D 53/028

See application file for complete search history.

(56) **References Cited**

U.S. PATENT DOCUMENTS

D611,506 S	3/2010	Loew	
D624,567 S	9/2010	Kelley	
D629,818 S	12/2010	Rummer	
D632,313 S	2/2011	Kelley	
D670,746 S	11/2012	Ewringmann	
D676,466 S	2/2013	Ewringmann	
D708,233 S	7/2014	Furuki	
D715,333 S	10/2014	Jacobsthal	
D724,109 S	3/2015	Haro	
D751,611 S	3/2016	Smith	
D757,826 S	5/2016	Hartz	
D762,740 S	8/2016	Okuyama	
D766,339 S	9/2016	Hanke	
D784,426 S	4/2017	Okuyama	
D786,945 S	5/2017	Smith	
D795,308 S	8/2017	Sauvaget	
D795,309 S	8/2017	Sauvaget	
D846,599 S *	4/2019	Ryan D15/31

* cited by examiner

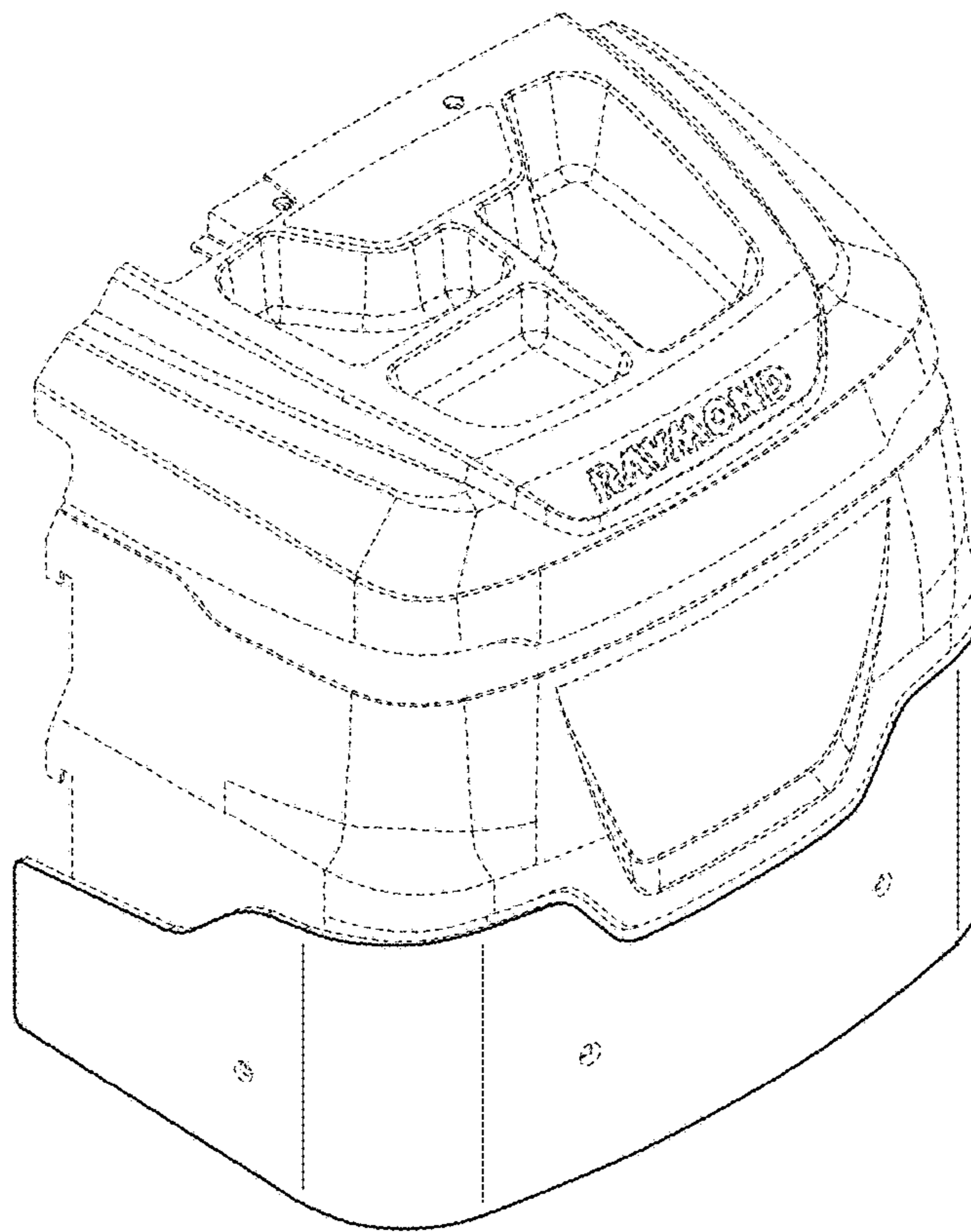

FIG. 1

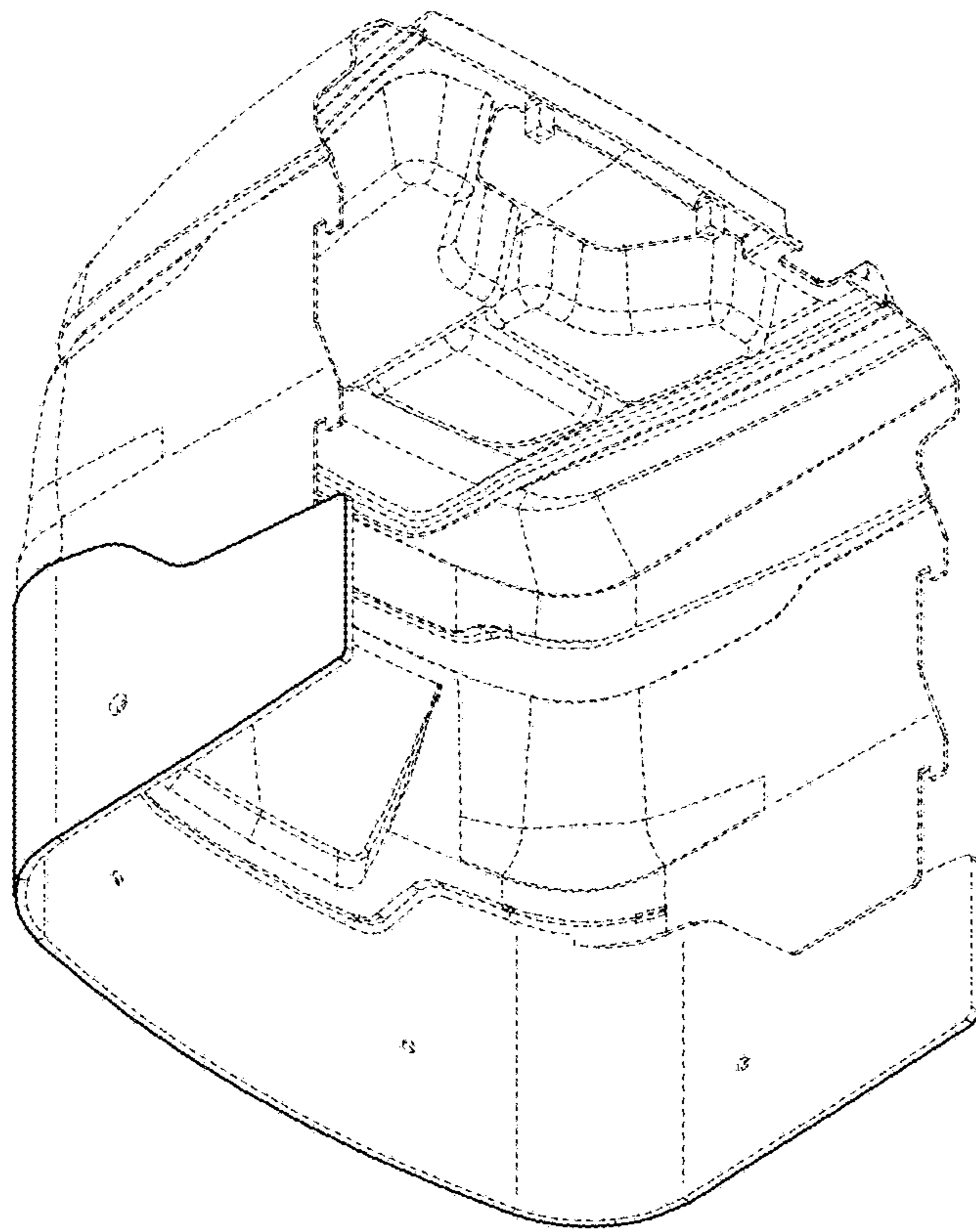

FIG. 2

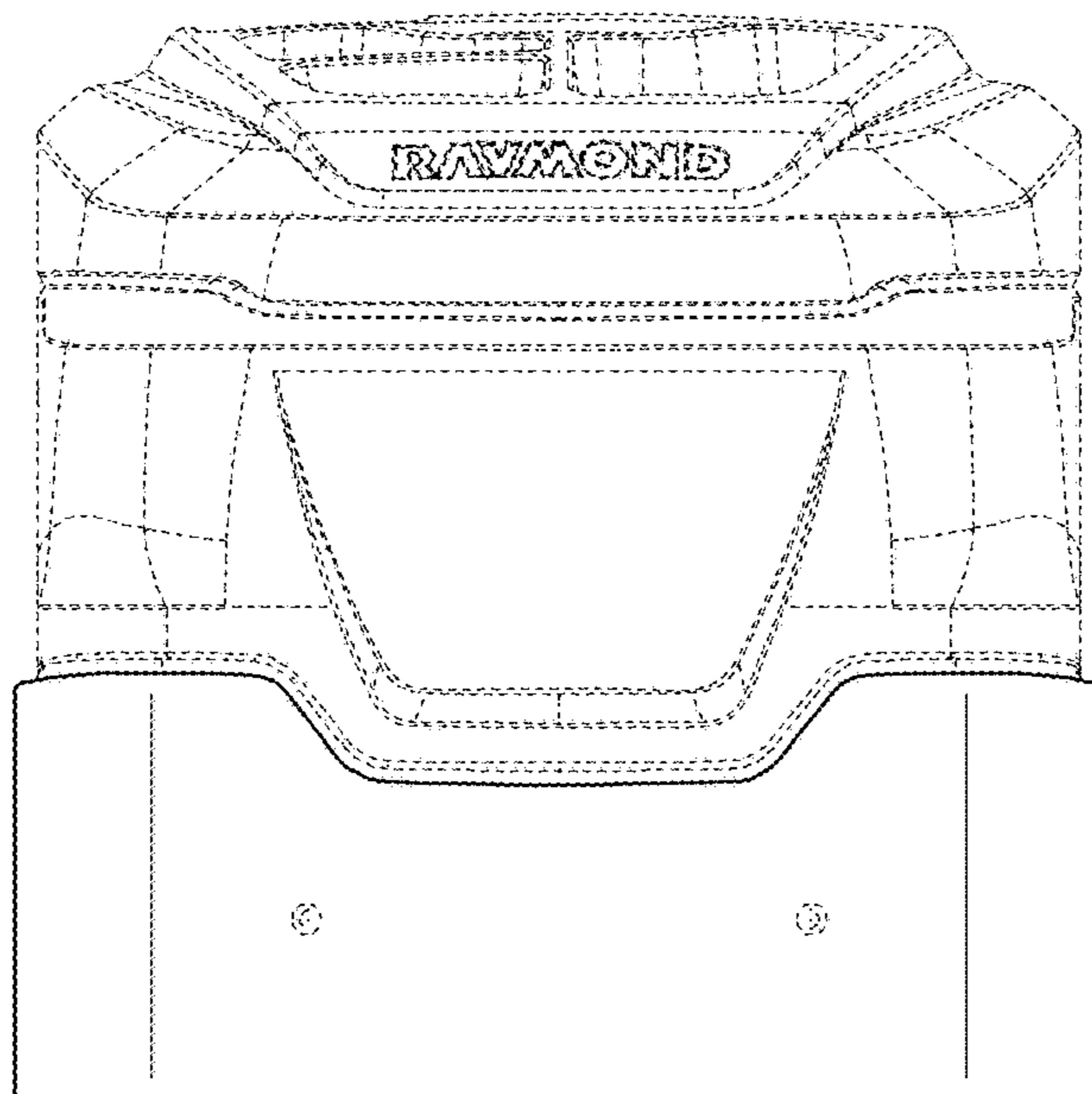

FIG. 3

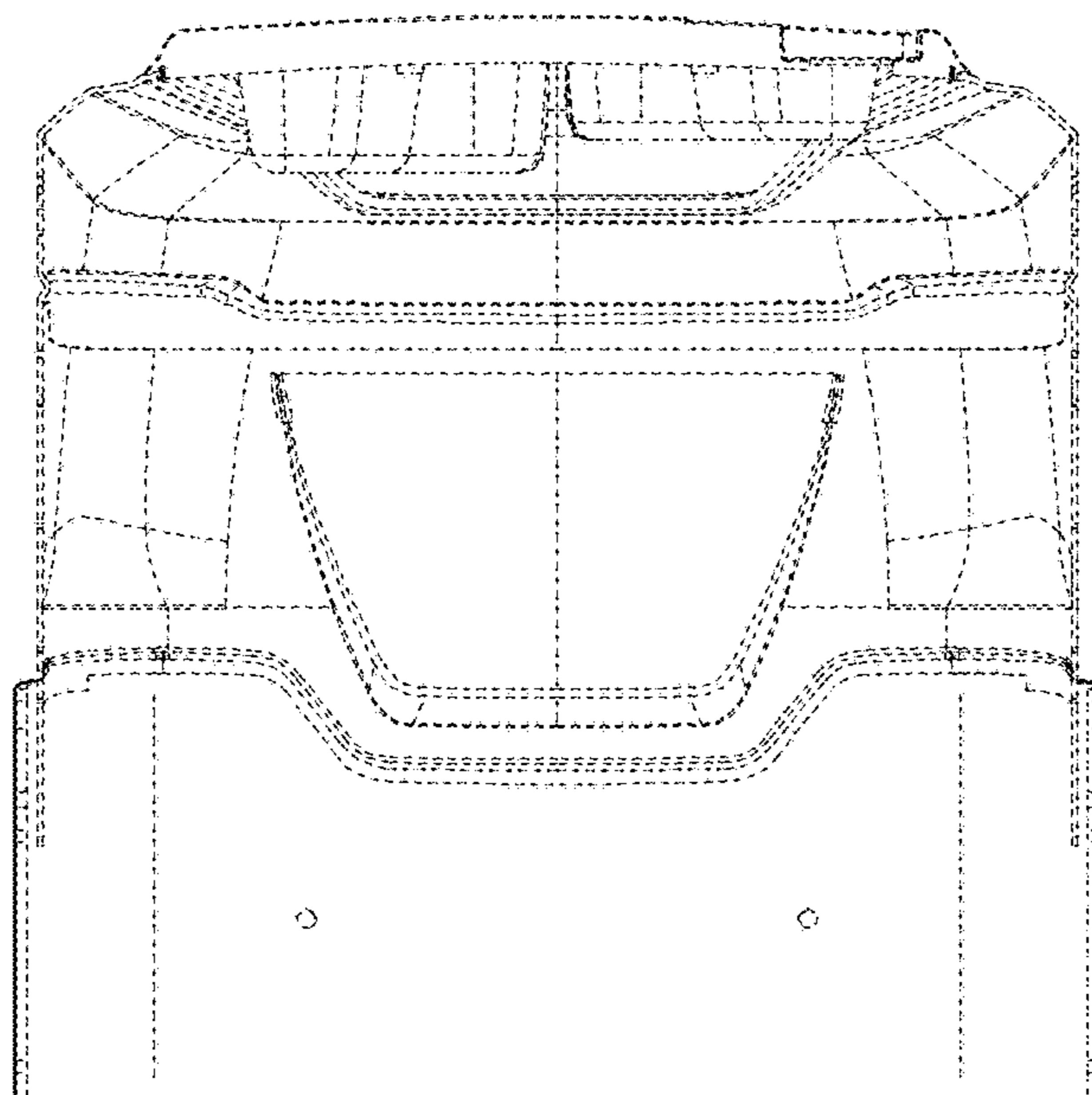

FIG. 4

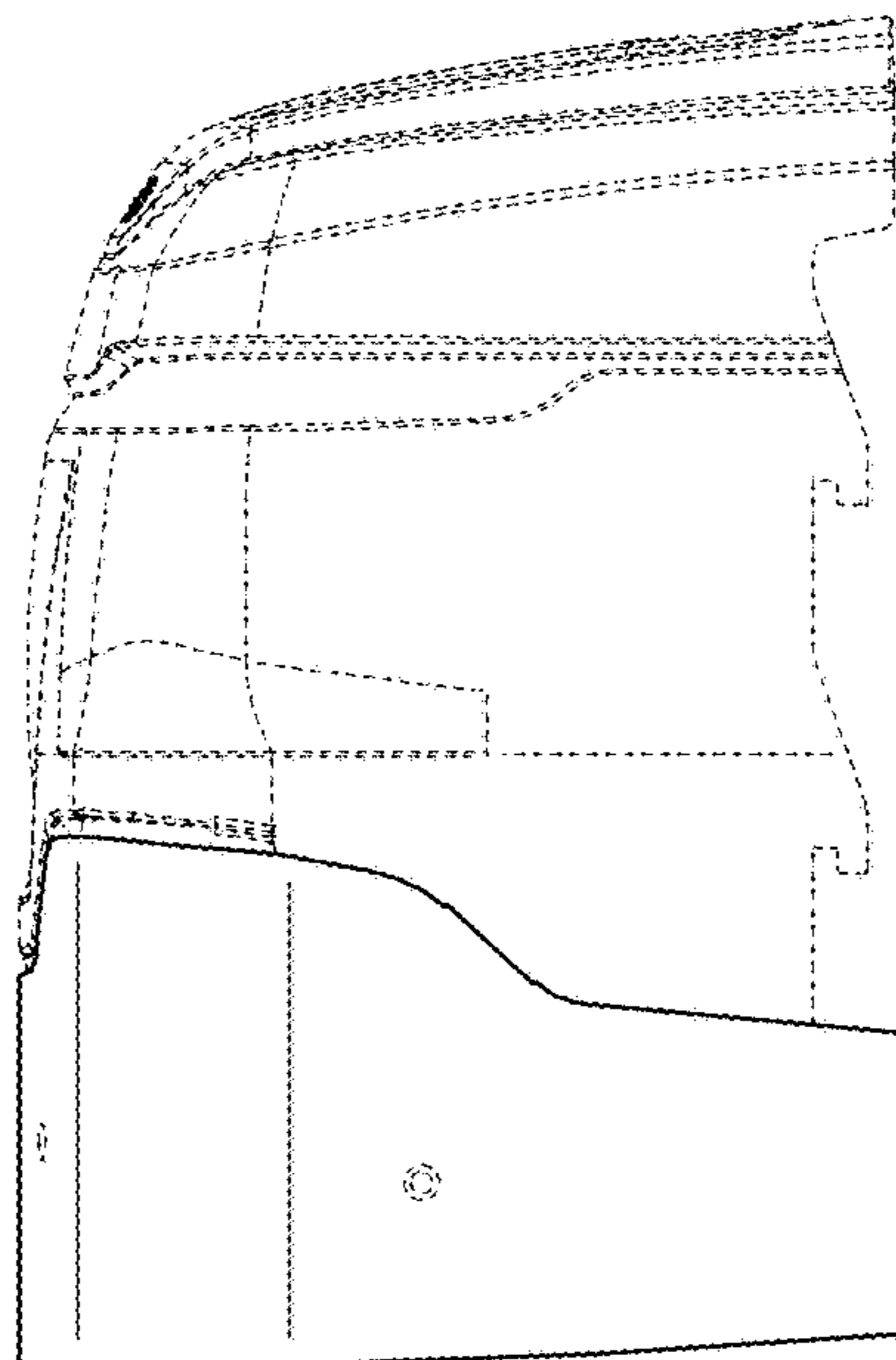

FIG. 5

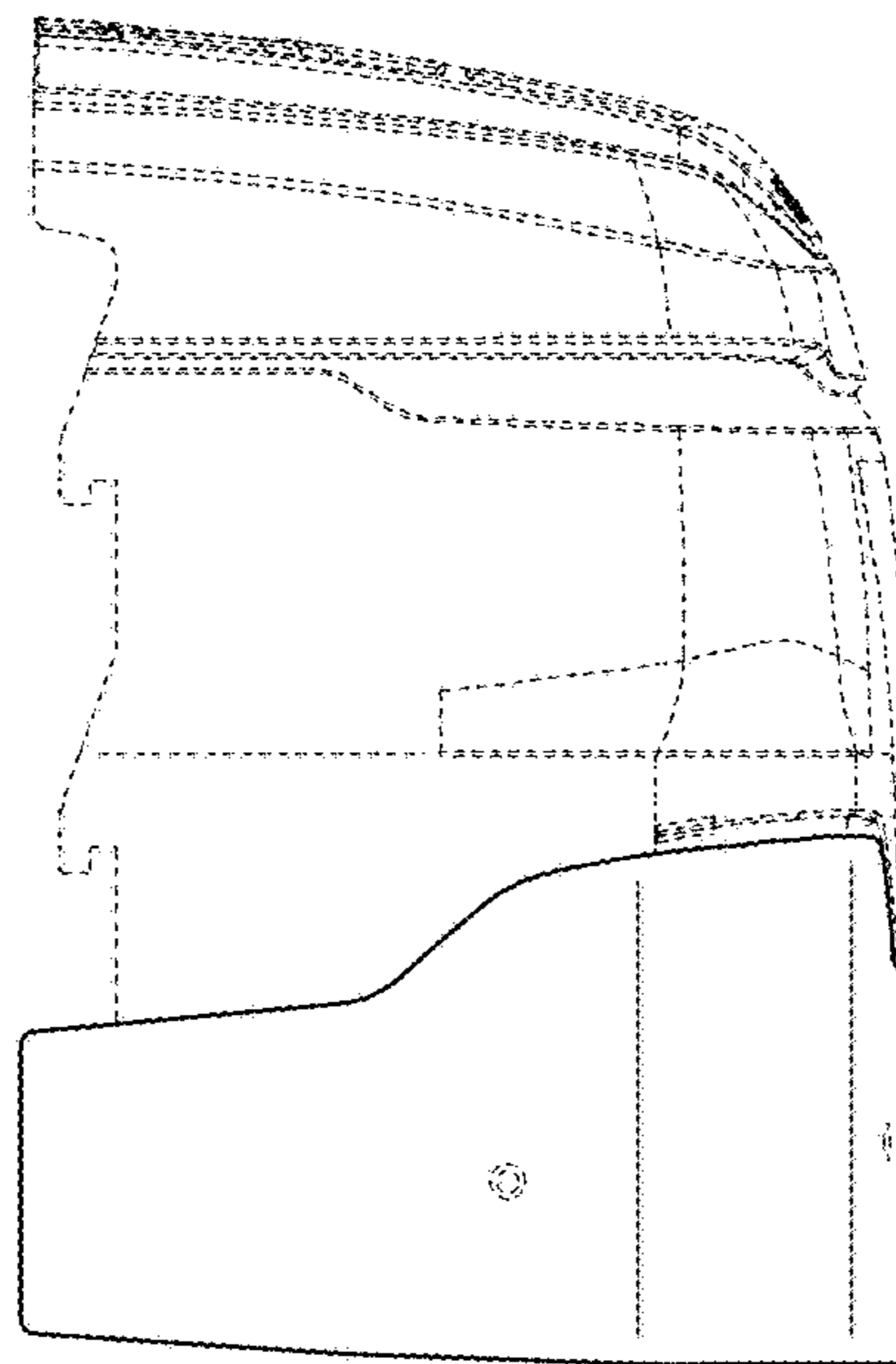

FIG. 6

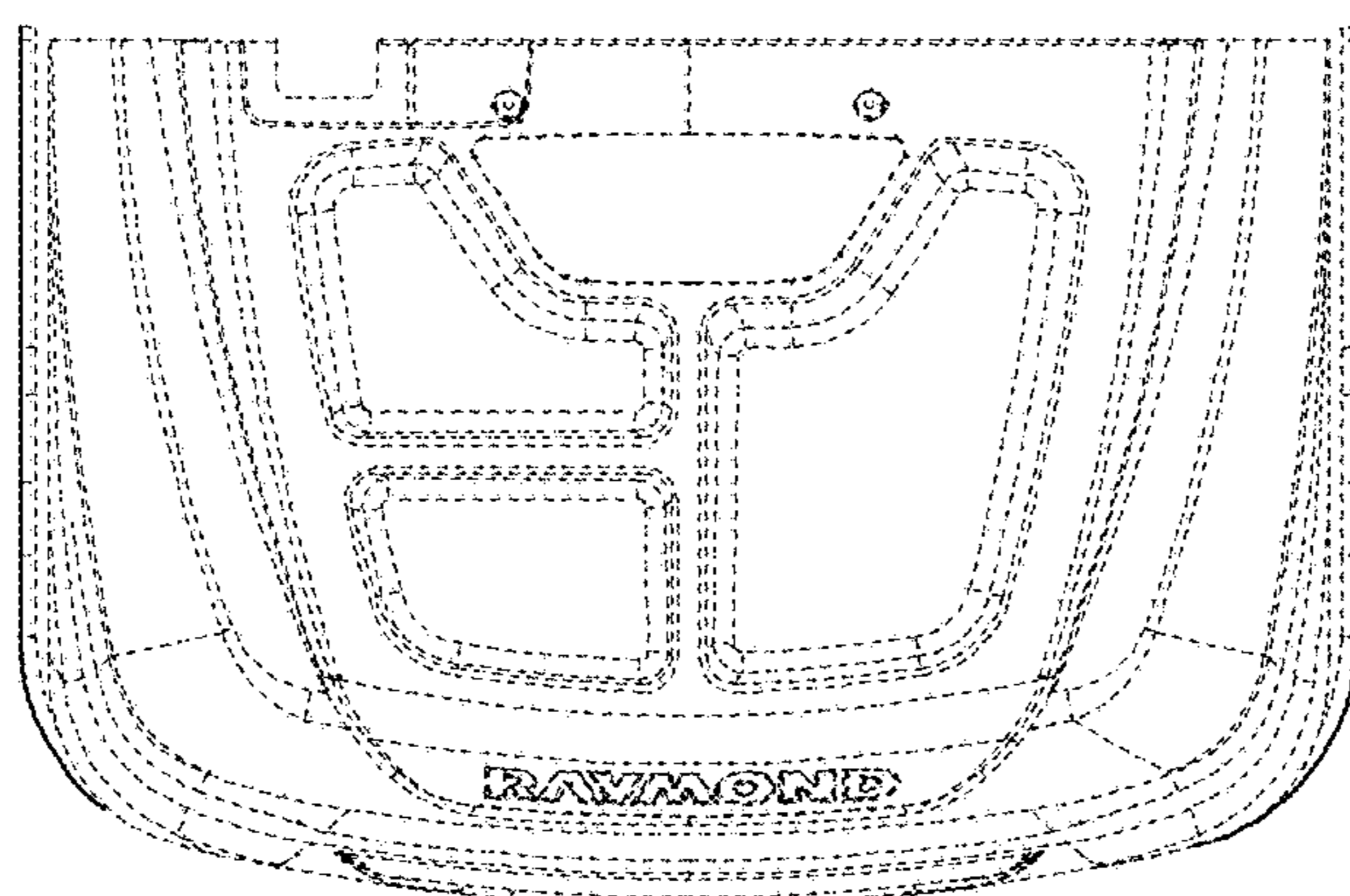

FIG. 7

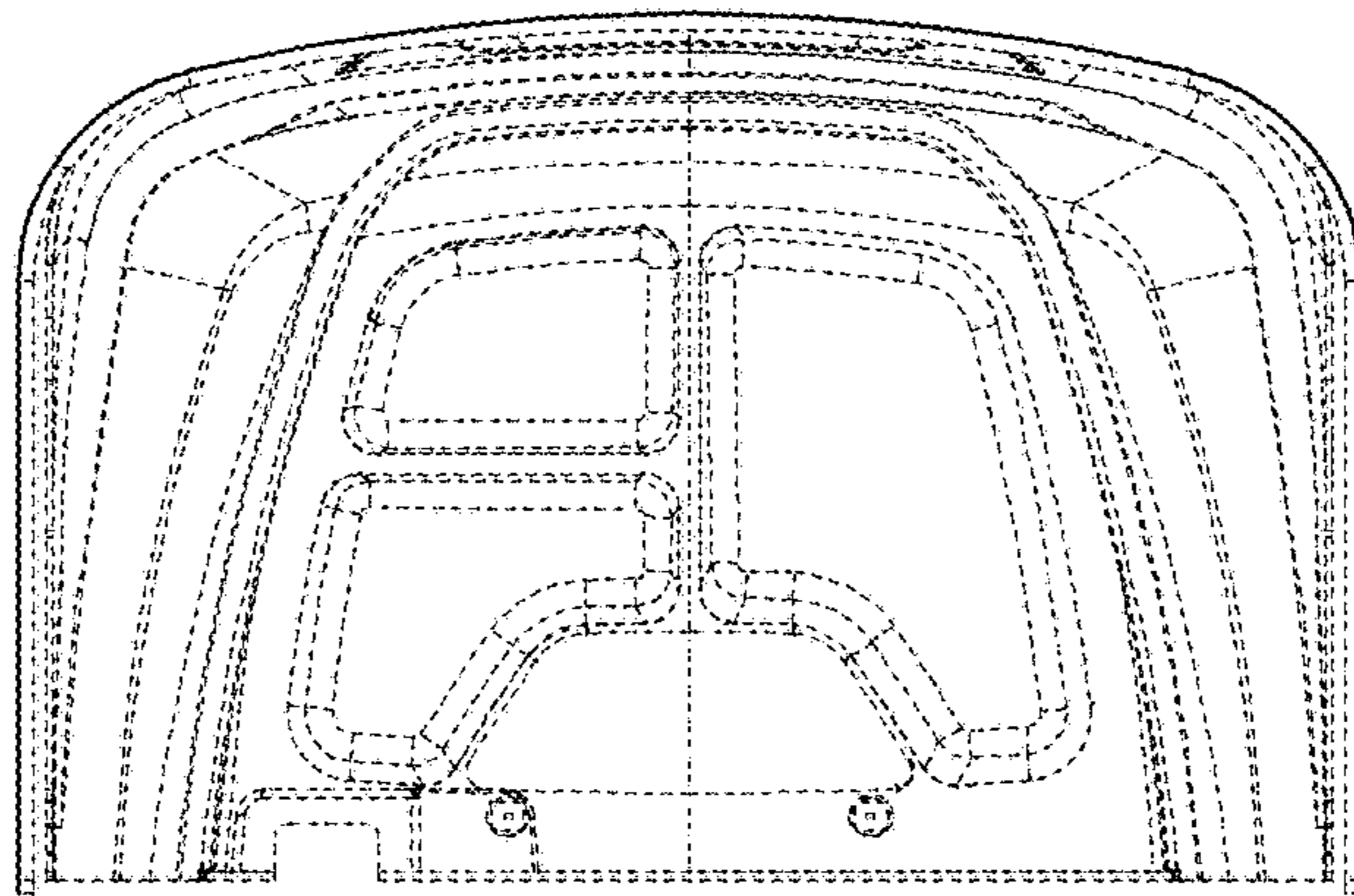

FIG. 8

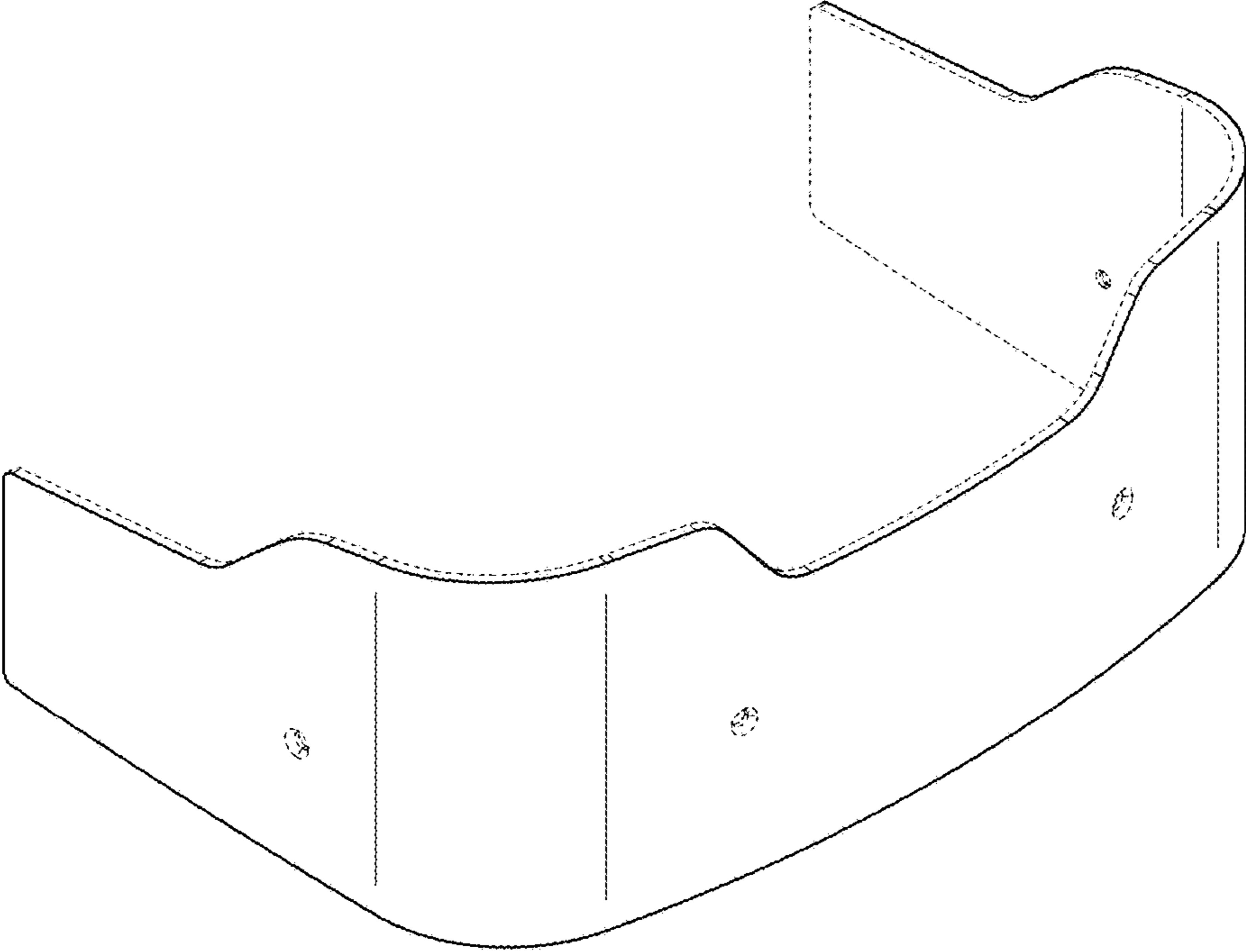

FIG. 9

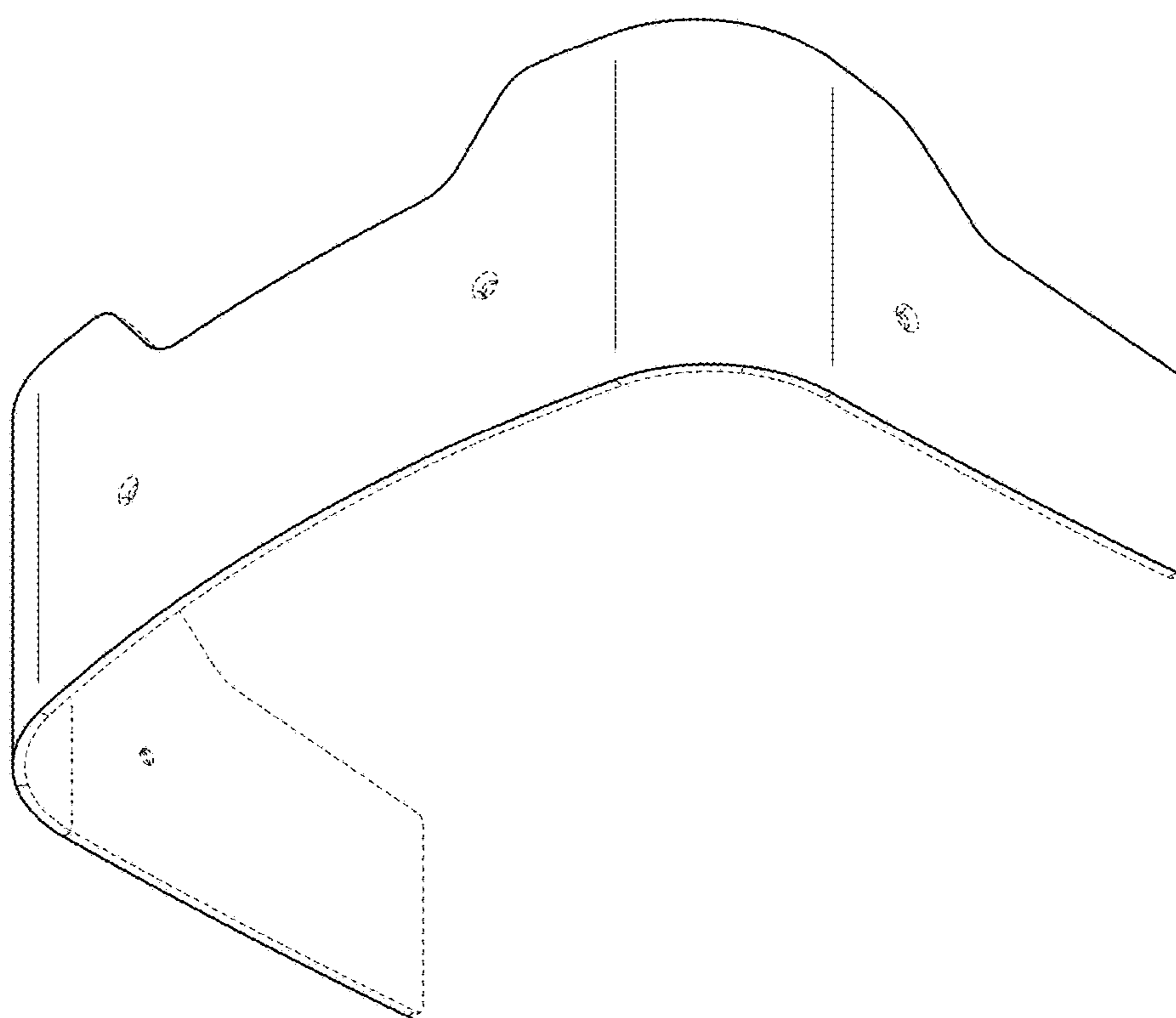

FIG. 10

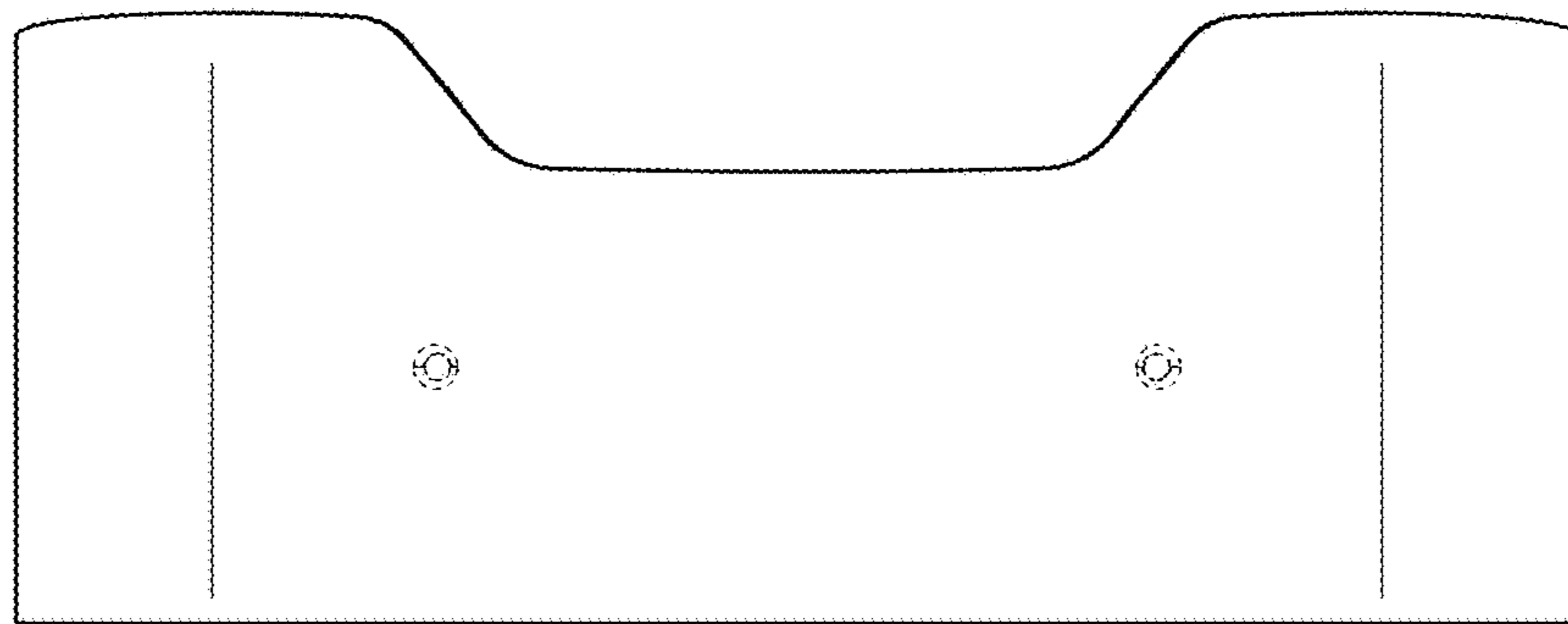

FIG. 11

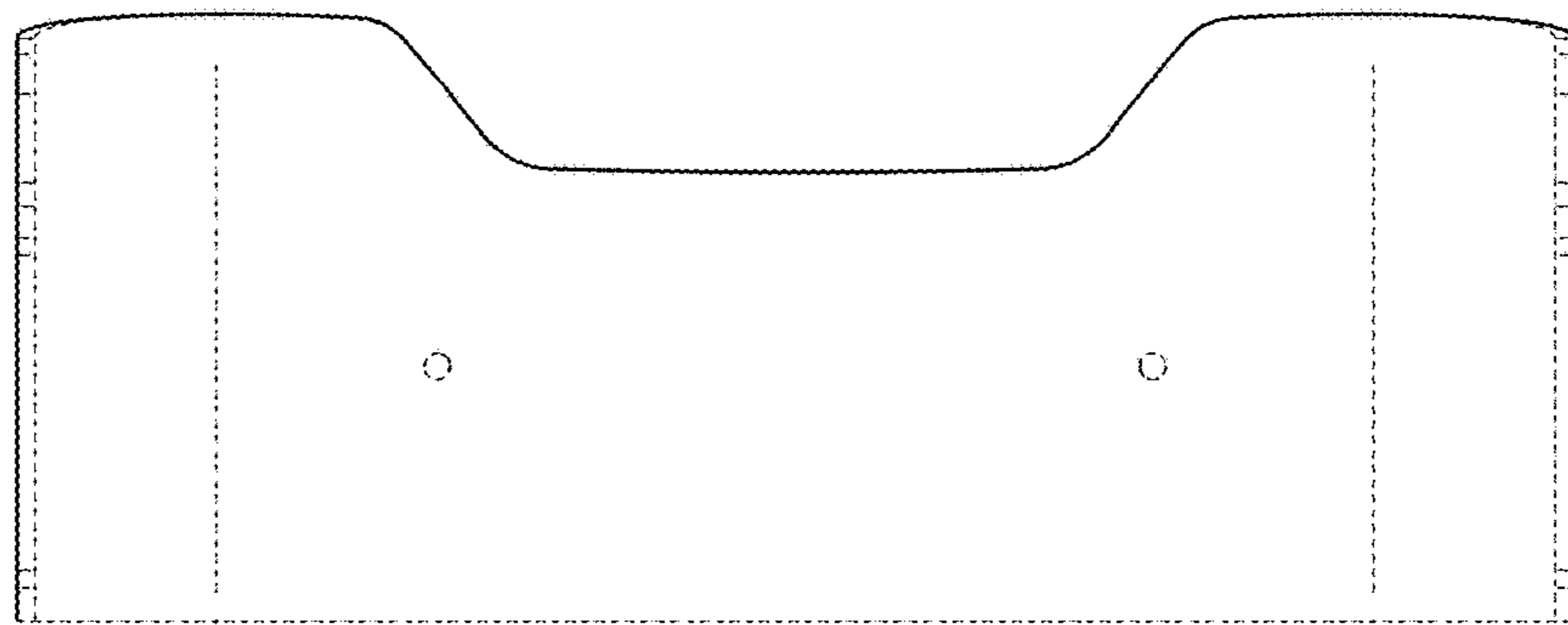

FIG. 12

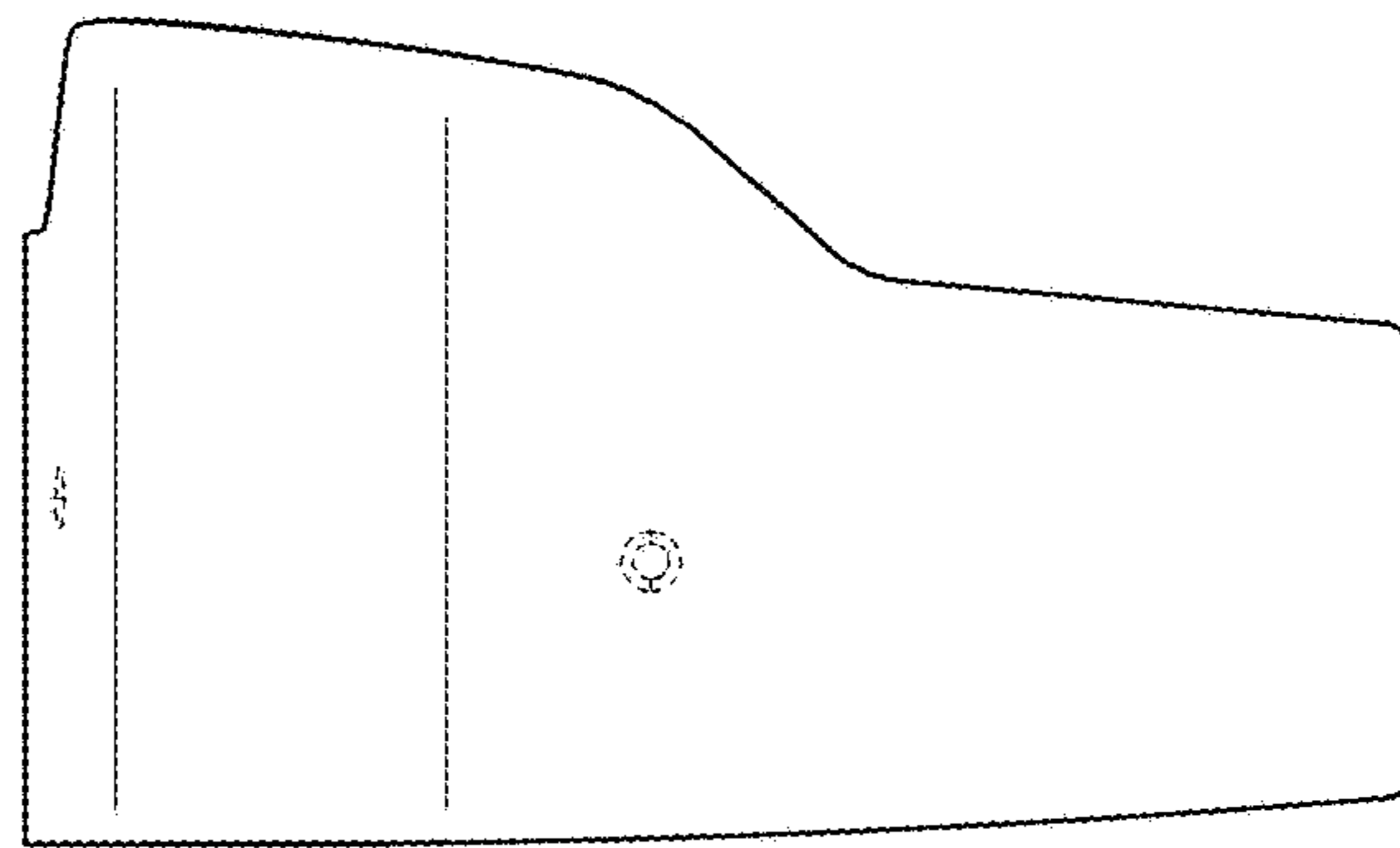

FIG. 13

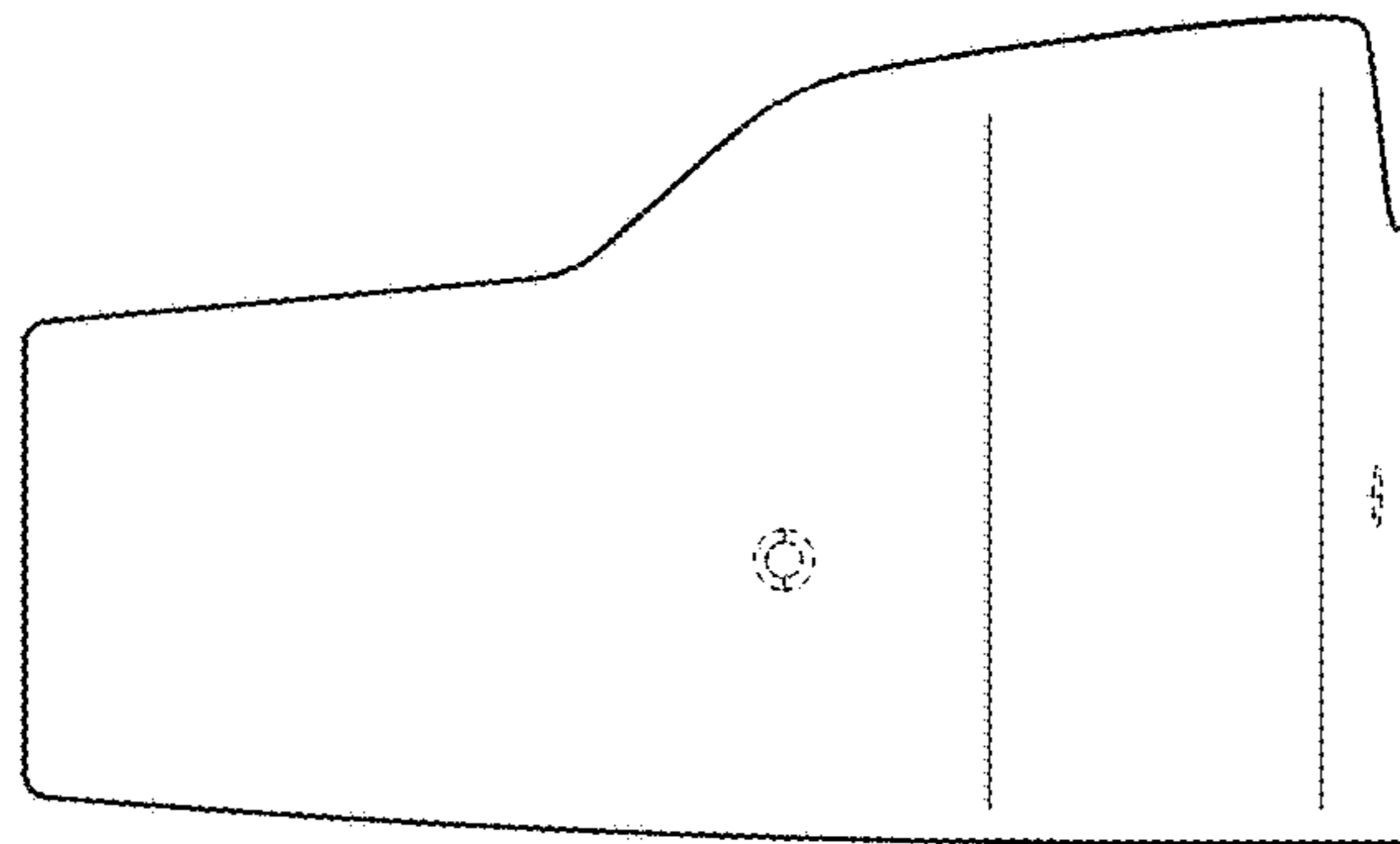

FIG. 14

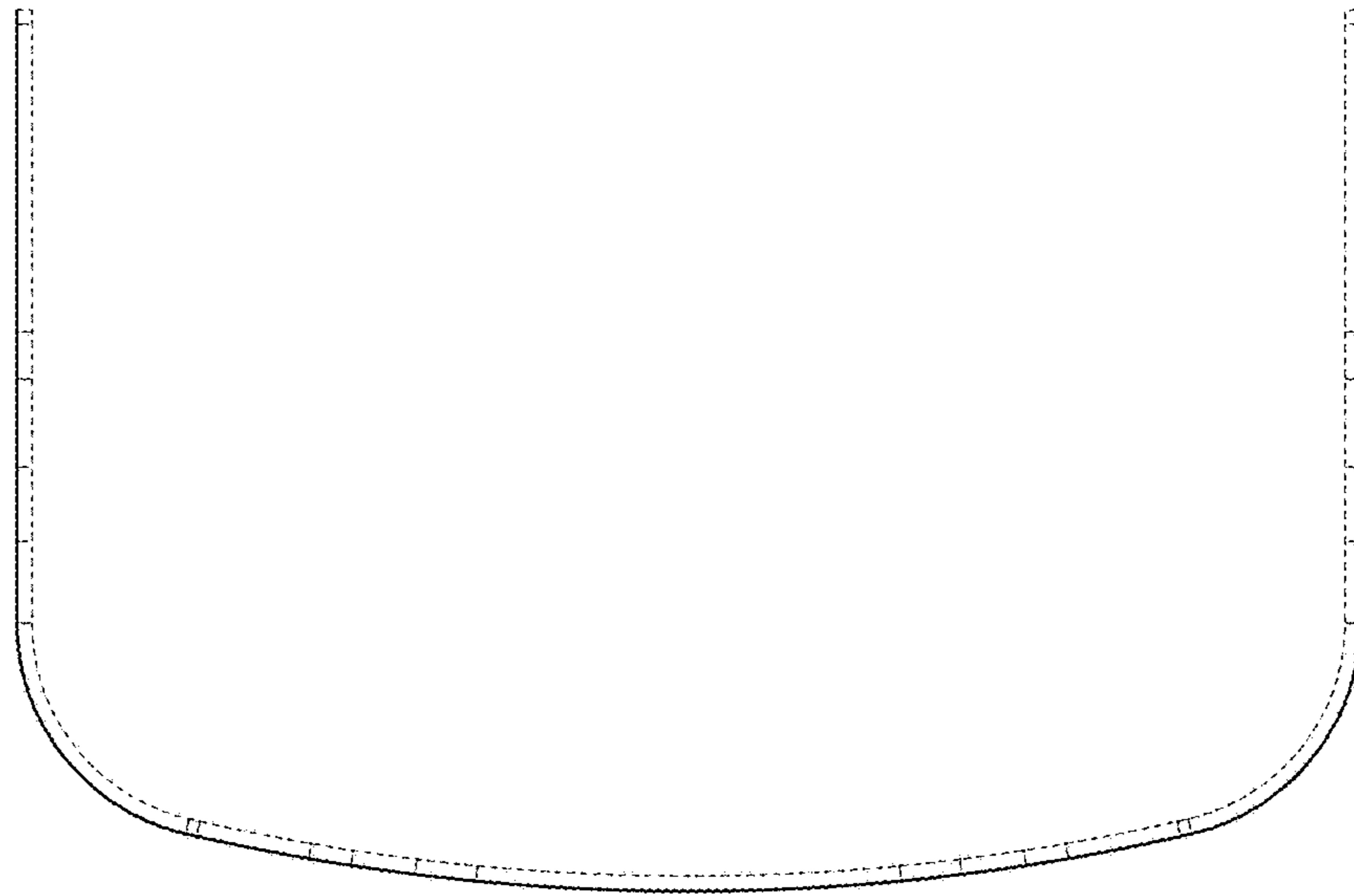

FIG. 15

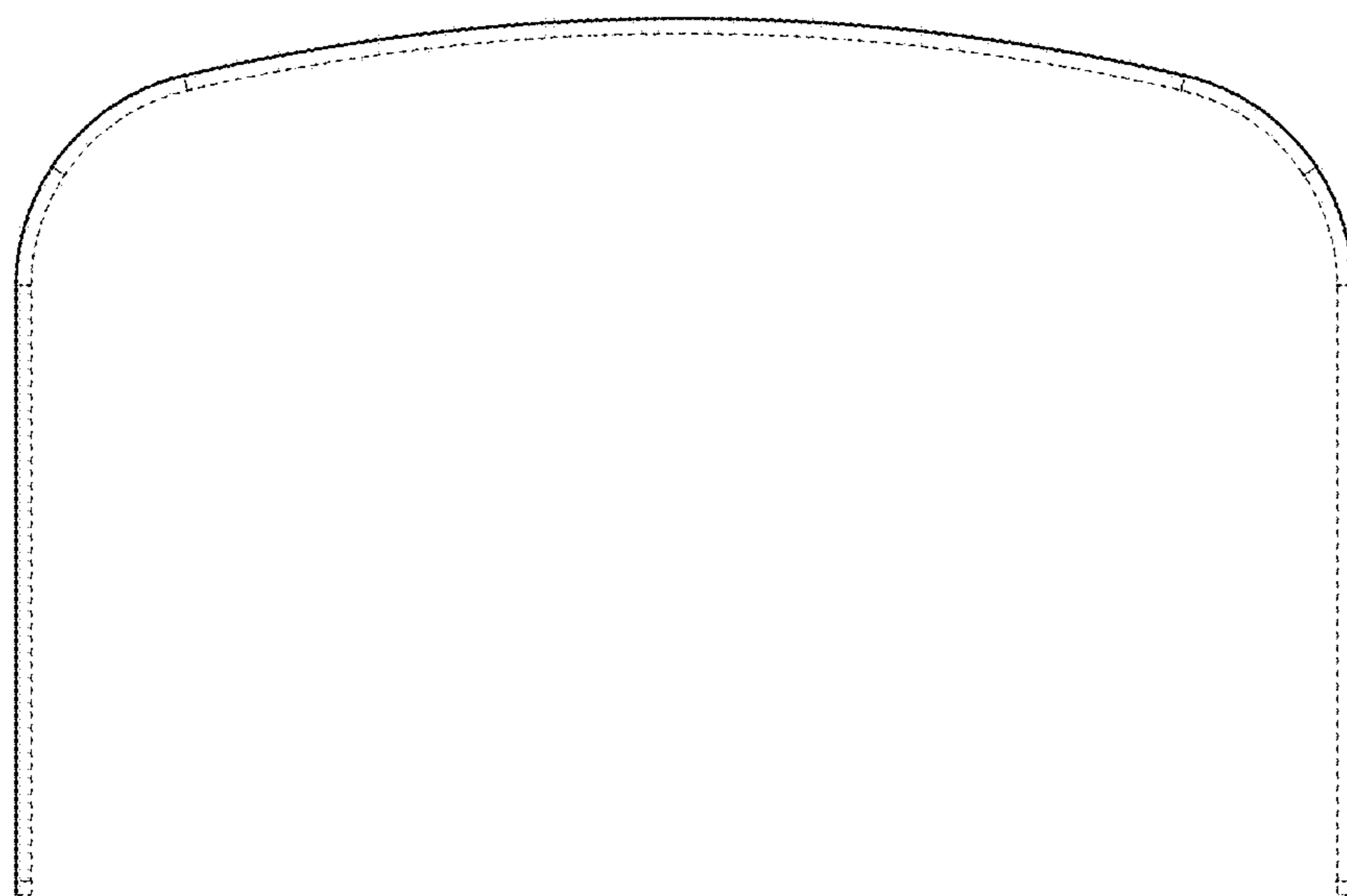

FIG. 16