

US00D867222S

(12) **United States Design Patent** (10) **Patent No.:** **US D867,222 S**
Inose (45) **Date of Patent:** **** Nov. 19, 2019**

(54) **MOTORCYCLE**
(71) Applicant: **YAMAHA HATSUDOKI**
KABUSHIKI KAISHA, Shizuoka-ken
(JP)
(72) Inventor: **Tadashi Inose**, Tokyo (JP)
(73) Assignee: **YAMAHA HATSUDOKI**
KABUSHIKI KAISHA (JP)
(**) Term: **15 Years**
(21) Appl. No.: **29/645,566**
(22) Filed: **Apr. 27, 2018**
(30) **Foreign Application Priority Data**

Oct. 31, 2017 (JP) 2017-024184

(51) **LOC (12) Cl.** **12-11**

(52) **U.S. Cl.**
USPC **D12/110**

(58) **Field of Classification Search**
USPC D12/110, 111, 117; D21/432, 538
CPC B62K 11/00; B62K 11/02; B62K 11/04;
B62K 11/10; B62K 17/00; B62K 19/00;
B62K 2202/00

See application file for complete search history.

(56) **References Cited**

U.S. PATENT DOCUMENTS

D269,170 S * 5/1983 Aoyama D12/110
D270,047 S * 8/1983 Kataoka D12/110
D273,854 S * 5/1984 Ishiyama D12/110
D384,600 S * 10/1997 Miwa D12/110
D384,601 S * 10/1997 Hiruma D12/110
D395,849 S * 7/1998 Maruyama D12/110
D419,922 S * 2/2000 Yamase D12/110
D430,822 S * 9/2000 Sakaguchi D12/110

D482,639 S * 11/2003 Yamamoto D12/110
D497,329 S * 10/2004 Yamamoto D12/110
D497,330 S * 10/2004 Fukuyama D12/110
D513,481 S * 1/2006 Lin D12/110
D517,956 S * 3/2006 Kishi D12/110
D523,783 S * 6/2006 Sugimoto D12/110
D524,191 S * 7/2006 Sugimoto D12/110
D526,249 S * 8/2006 Tanaka D12/110
D549,136 S * 8/2007 Yu D12/110
D559,155 S * 1/2008 Sakata D12/110
D566,626 S * 4/2008 Sakata D12/110
D581,840 S * 12/2008 Ichihara D12/110
D590,302 S * 4/2009 Tanaka D12/110
D594,784 S * 6/2009 Ichihara D12/110
D598,330 S * 8/2009 Miyanishi D12/110
D601,927 S * 10/2009 Watanabe D12/110

(Continued)

OTHER PUBLICATIONS

Japanese Office Action, dated May 30, 2018, issued in correspond-
ing Japanese Patent Application No. 2017-024184. Total 3 pages.

(Continued)

Primary Examiner — Darlington Ly

(74) *Attorney, Agent, or Firm* — Ostrolenk Faber LLP

(57) **CLAIM**

The ornamental design for a motorcycle, as shown.

DESCRIPTION

FIG. 1 is a front and left side perspective view of a motorcycle showing my new design;
FIG. 2 is a rear and right side perspective view thereof;
FIG. 3 is a front elevation view thereof;
FIG. 4 is a rear elevation view thereof;
FIG. 5 is a right side elevation view thereof;
FIG. 6 is a left side elevation view thereof;
FIG. 7 is a top plan view thereof; and,
FIG. 8 is a bottom plan view thereof.

1 Claim, 8 Drawing Sheets

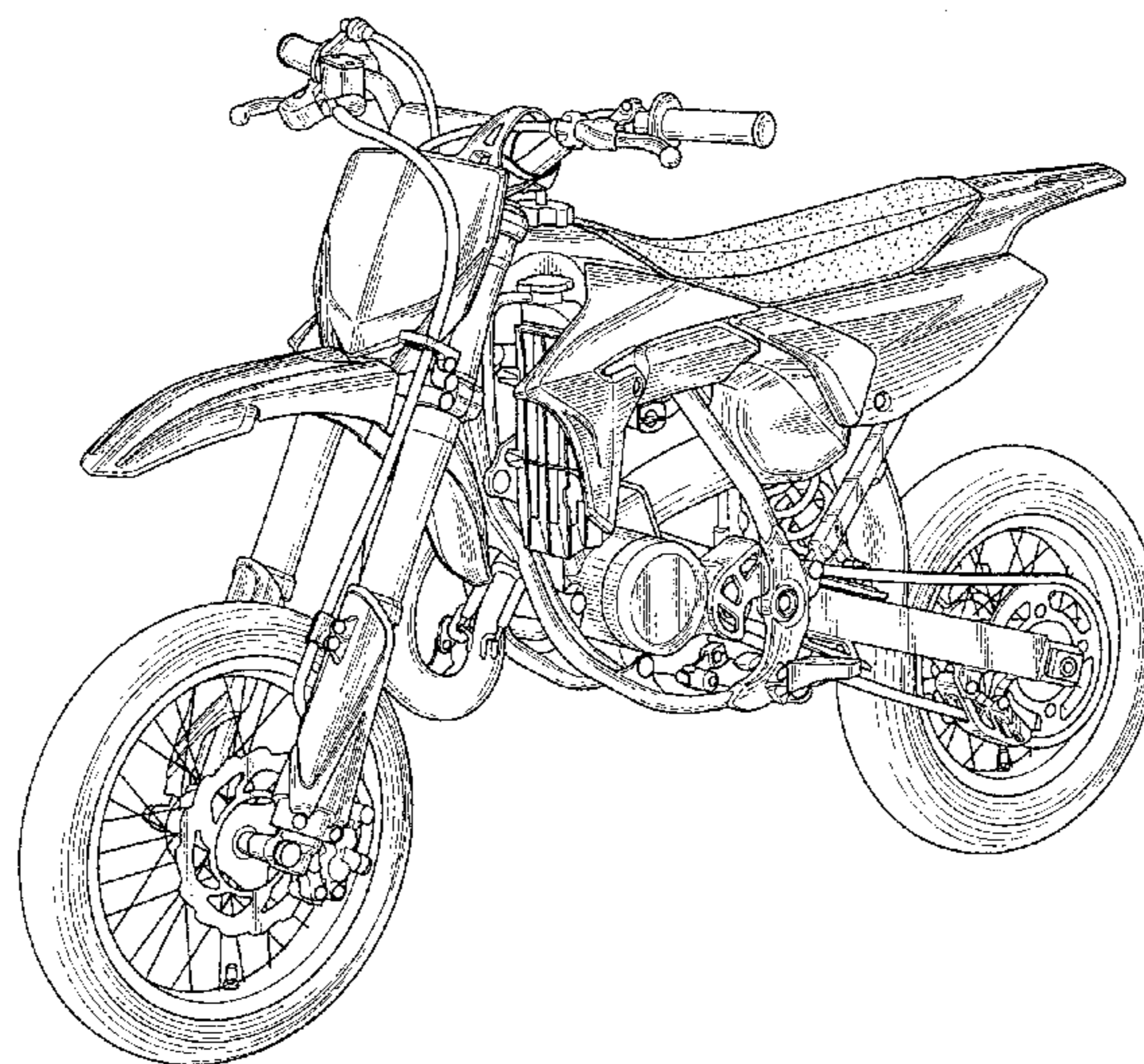

(56)

References Cited

U.S. PATENT DOCUMENTS

D603,300	S	*	11/2009	Fukuyama	D12/110
D609,609	S	*	2/2010	Hayashi	D12/110
D609,610	S	*	2/2010	Inose	D12/110
D621,301	S	*	8/2010	Hayashi	D12/110
D632,226	S	*	2/2011	Miyata	D12/110
D640,173	S	*	6/2011	Oyanagi	D12/110
D665,706	S	*	8/2012	Oyanagi	D12/110
D685,682	S	*	7/2013	Matsumura	D12/110
D724,496	S	*	3/2015	Takeda	D12/110
D735,086	S	*	7/2015	Talios	D12/110
D735,087	S	*	7/2015	Iimura	D12/110
D738,260	S	*	9/2015	Akita	D12/110
D738,789	S	*	9/2015	Inose	D12/110
D754,567	S	*	4/2016	Iimura	D12/110
D792,287	S	*	7/2017	Kobayashi	D12/110
D798,195	S	*	9/2017	Yu	D12/110
D809,433	S	*	2/2018	Kobayashi	D12/110
D825,393	S	*	8/2018	Miyata	D12/110
2013/0313034	A1	*	11/2013	Matsushima	B62K 11/00
						180/219
2015/0060178	A1	*	3/2015	Matsushima	F02M 35/162
						180/219
2017/0057338	A1	*	3/2017	Inagaki	B60K 11/08

OTHER PUBLICATIONS

Yamaha “Adoption of big logo, etc. Coloring & graphics changed Releasing 2018 model of 4 models for ‘Enduro’” *Revs Your Heart* (Jun. 30, 2017). Includes English translation. Total 2 pages.

* cited by examiner

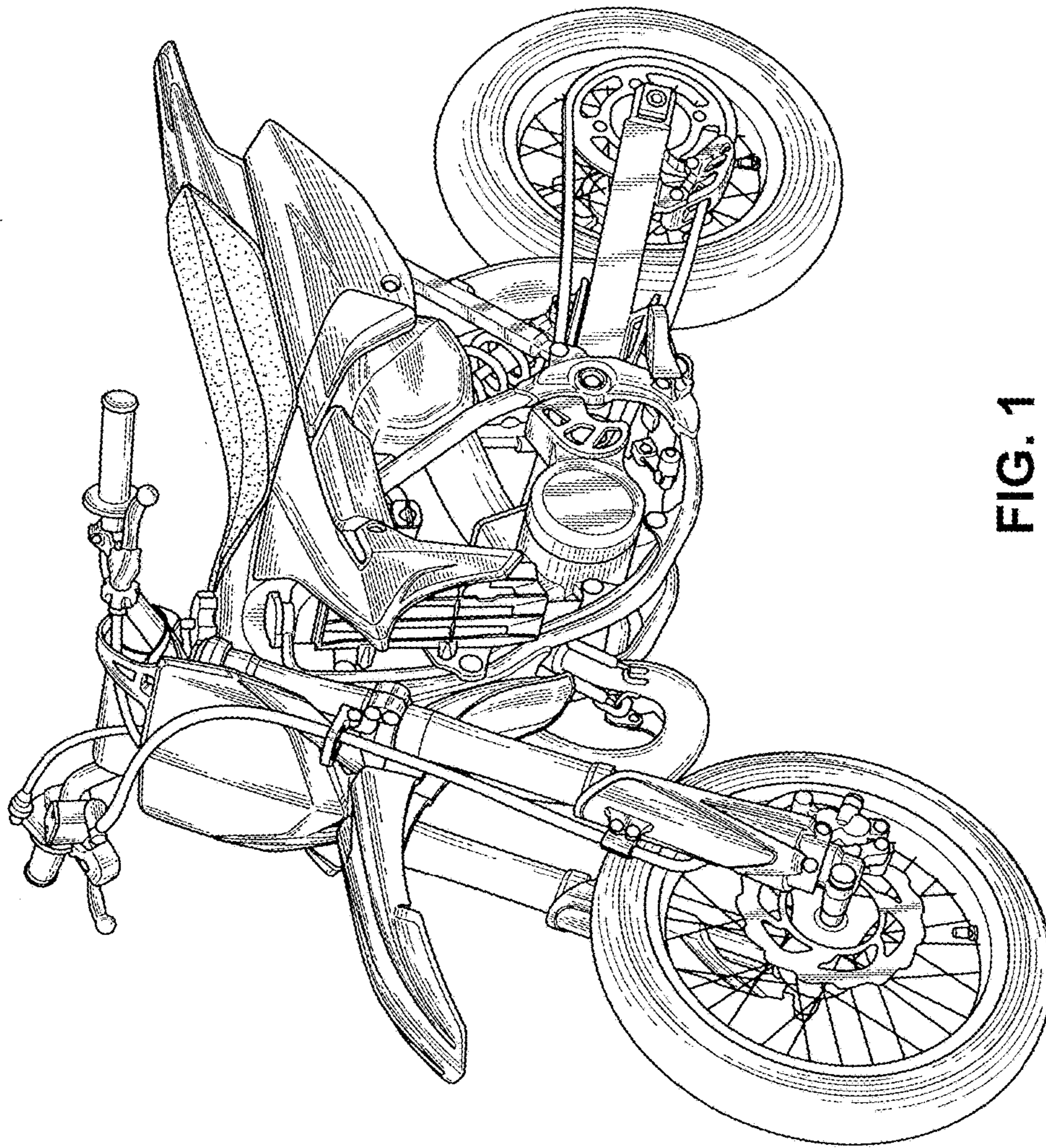

FIG. 1

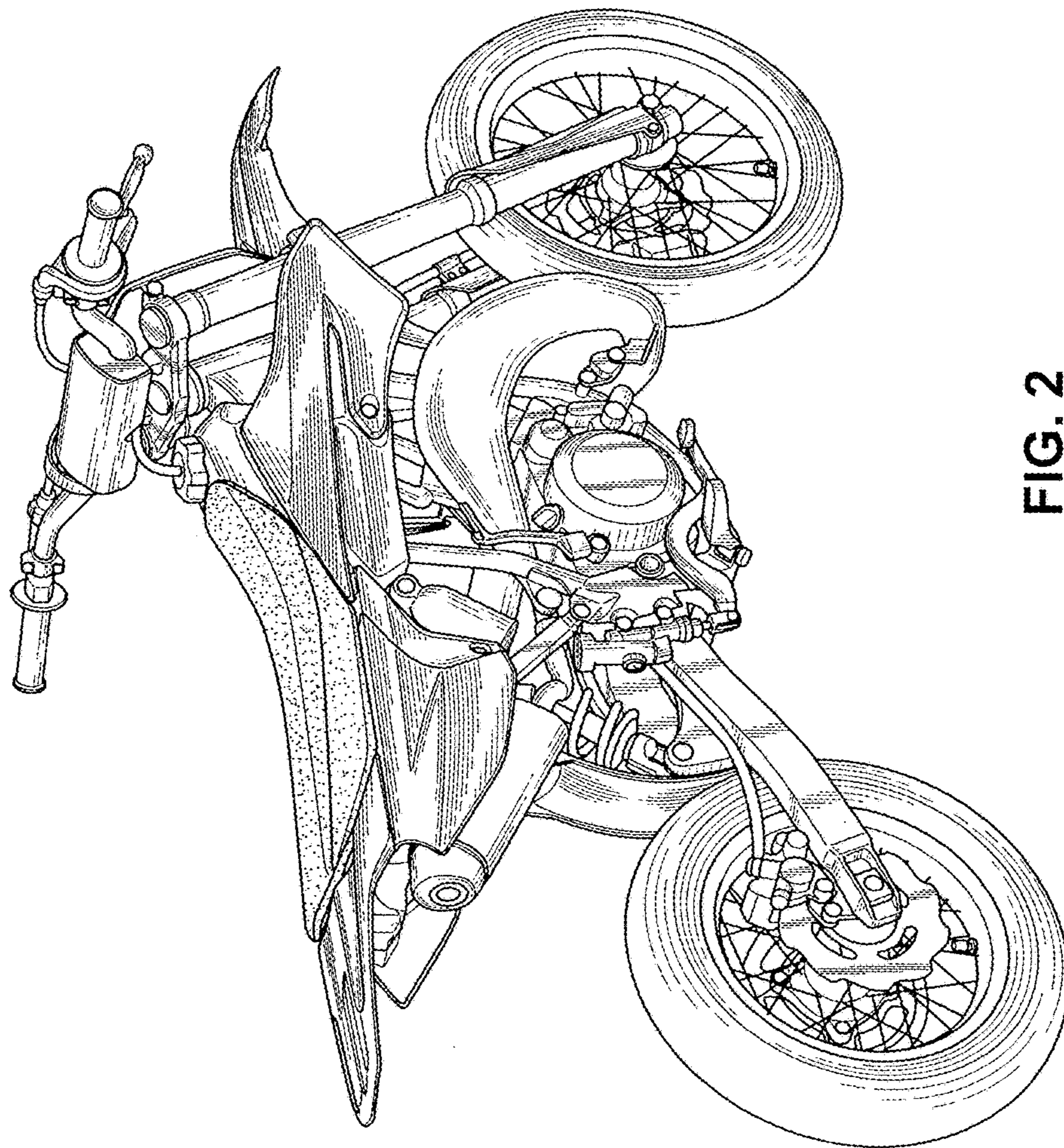

FIG. 2

FIG. 3

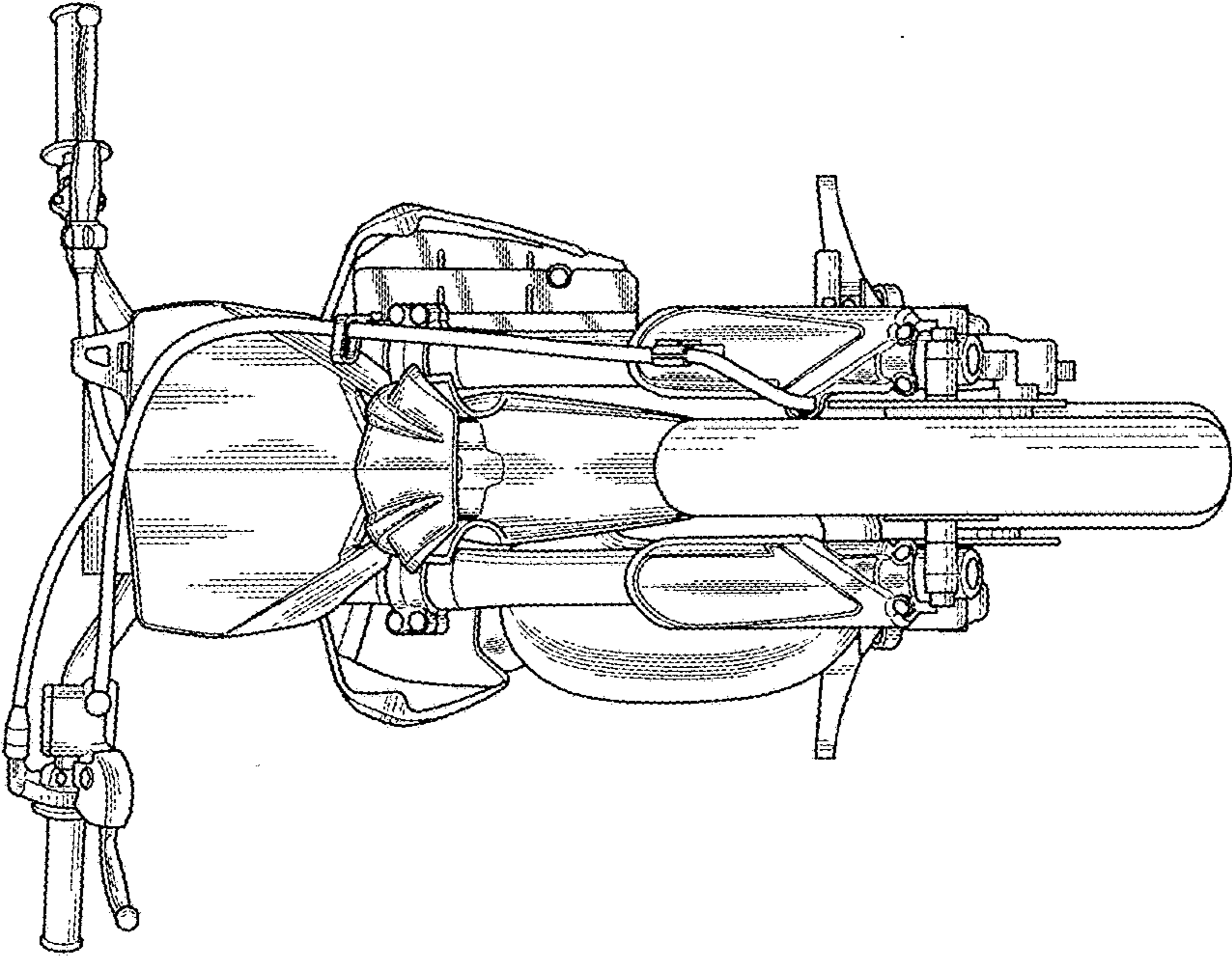
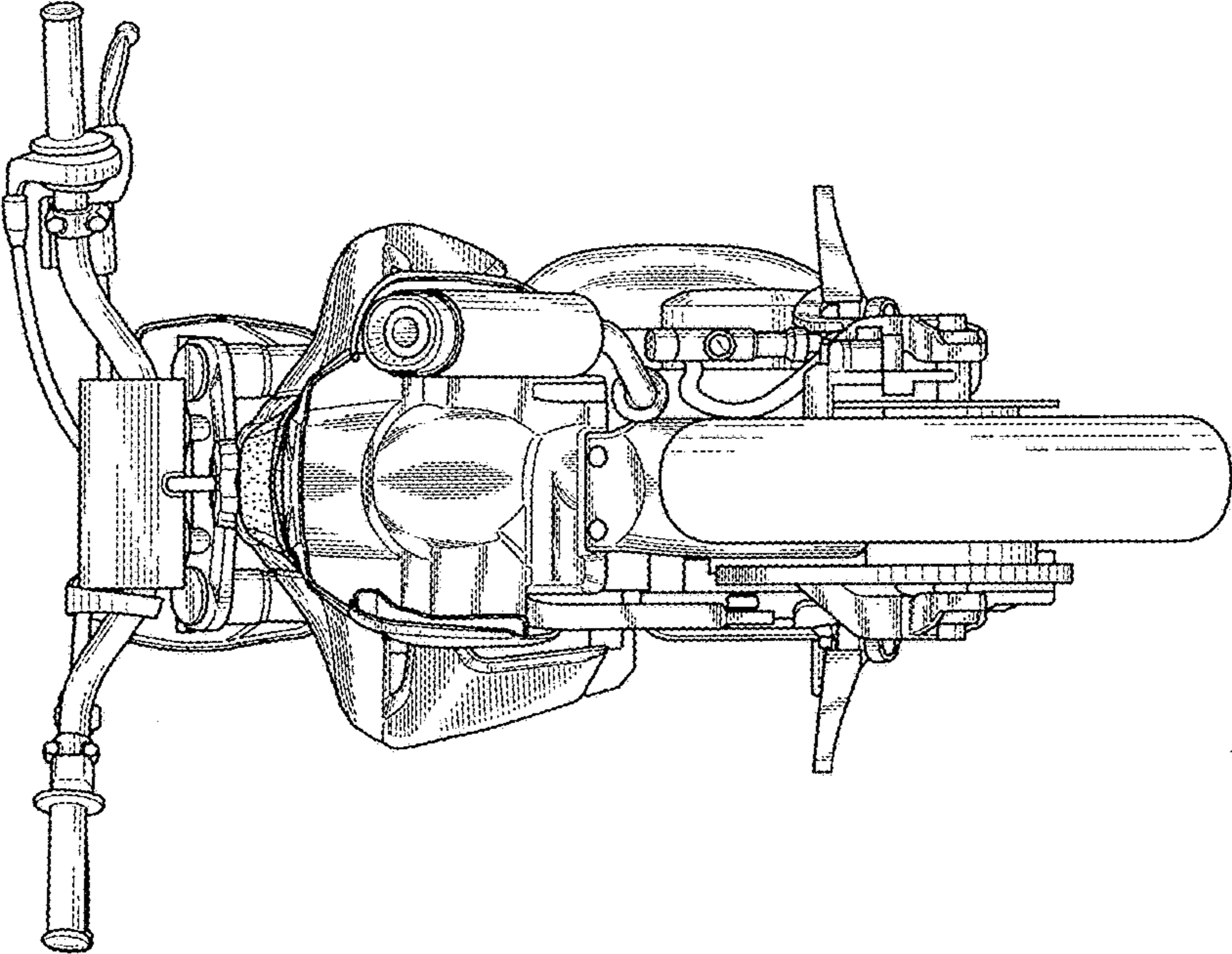

FIG. 4



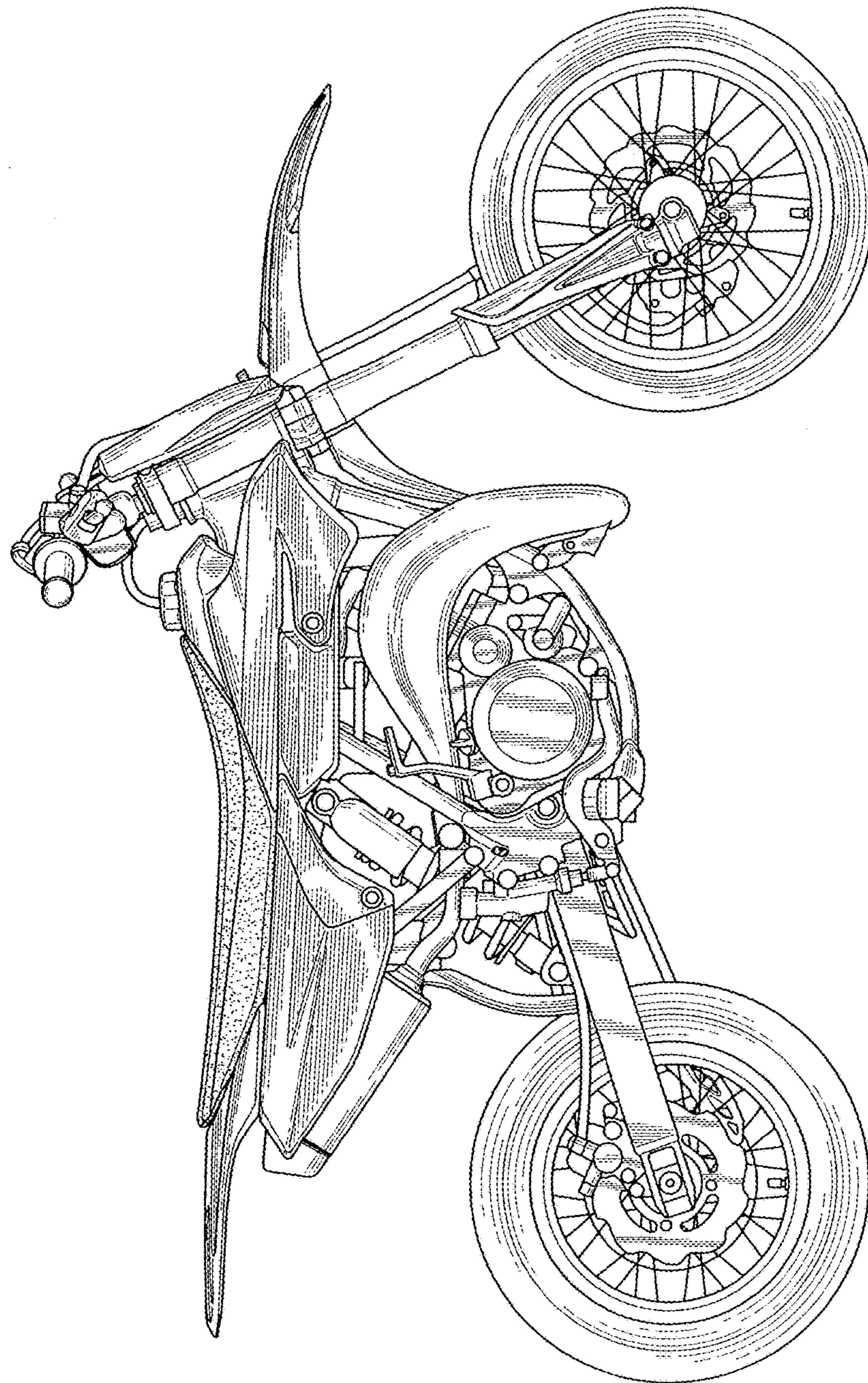

FIG. 5

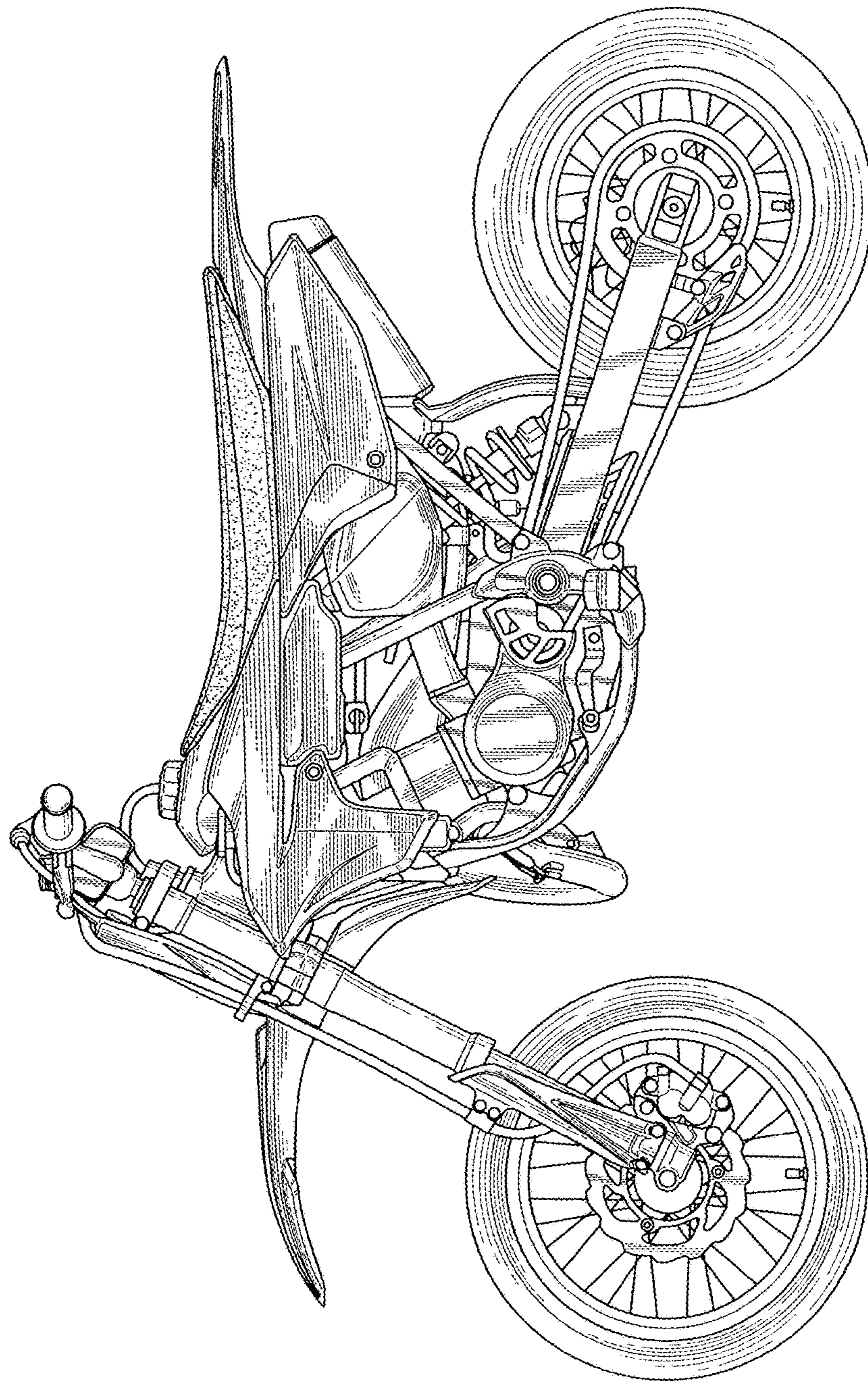

FIG. 6

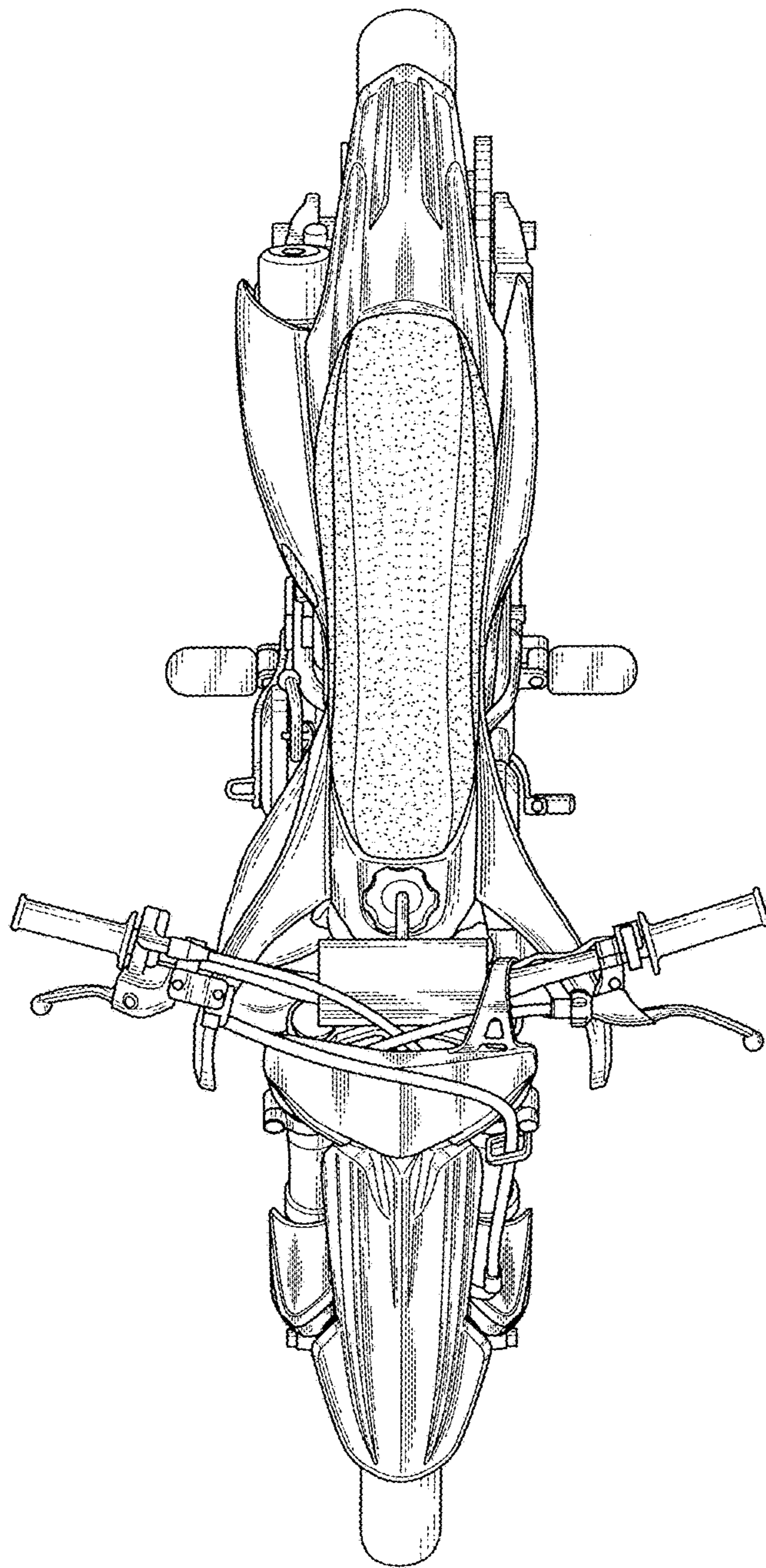

FIG. 7

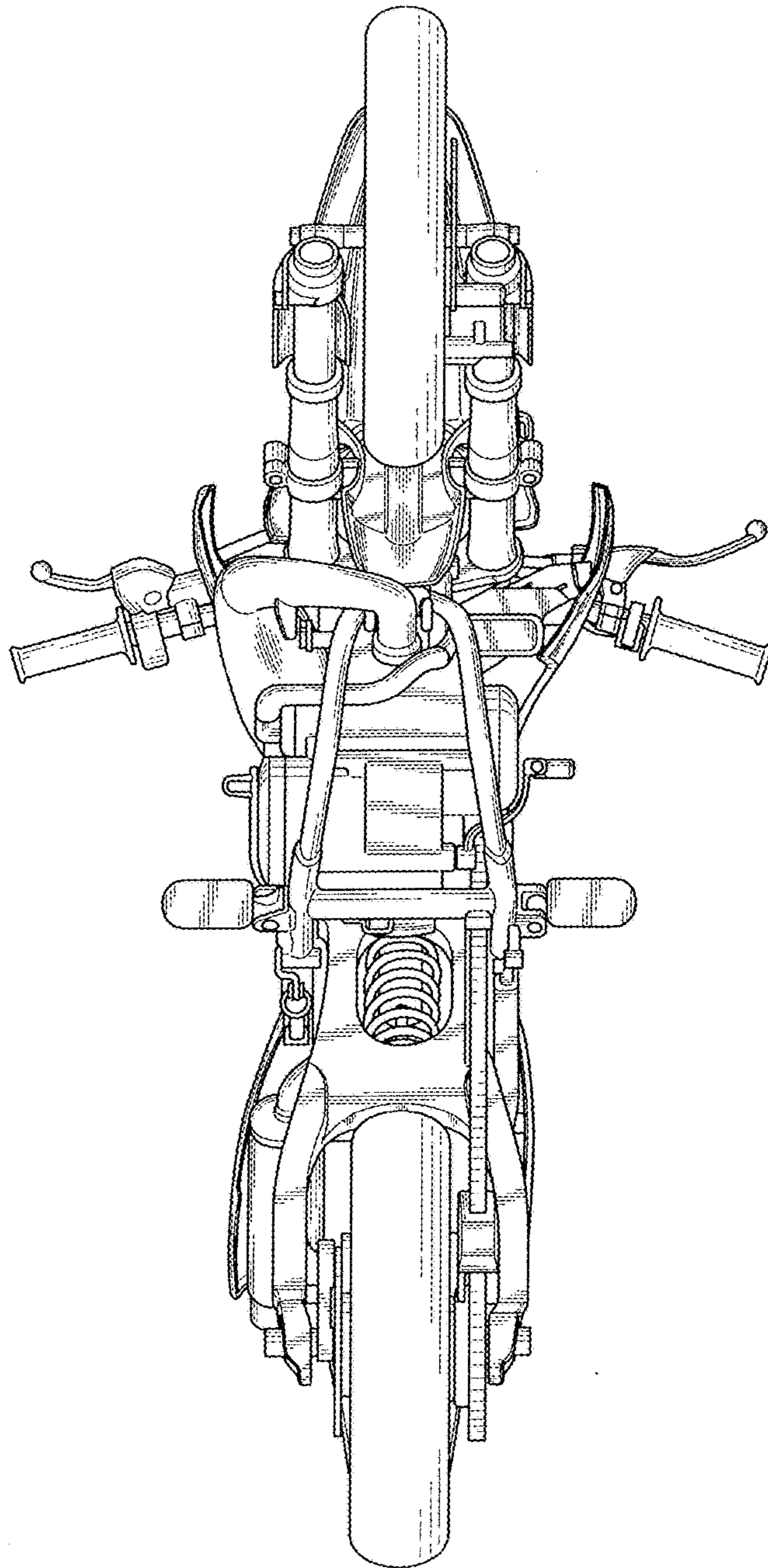

FIG. 8