



US00D867120S

(12) **United States Design Patent**
Moreau et al.

(10) **Patent No.:** **US D867,120 S**
(45) **Date of Patent:** **** Nov. 19, 2019**

(54) **AFFIXABLE AND REMOVABLE CLIP**

FOREIGN PATENT DOCUMENTS

(71) Applicant: **Ty-Flot, Inc.**, Manchester, NH (US)

JP D1275921 * 7/2006

(72) Inventors: **Darrell A. Moreau**, Manchester, NH (US); **Andre W. Moreau**, Bedford, NH (US)

OTHER PUBLICATIONS

(73) Assignee: **Ty-Flot, Inc.**, Manchester, NH (US)

2019 EDC Gear Multi Function Sheath Scabbard Belt Clip, DHGate website, <https://www.dhgate.com/product/1pcs-edc-gear-multi-function-sheath-scabbard/406984528.html#s1-12-1b;srpl0836420774>, site visited May 13, 2019.*

(**) Term: **15 Years**

(Continued)

(21) Appl. No.: **29/642,420**

Primary Examiner — John Windmuller

(22) Filed: **Mar. 29, 2018**

Assistant Examiner — John R Yeh

(51) **LOC (12) Cl.** **08-08**

(74) *Attorney, Agent, or Firm* — Dicke, Billig & Czaja, PLLC

(52) **U.S. Cl.**

USPC **D8/394**

(58) **Field of Classification Search**

USPC D8/394-396, 367; D28/42; D26/85, 26; D21/451-453

CPC B25B 5/16; B25B 7/14; A61F 2/46; A61M 39/28; E04H 17/16

See application file for complete search history.

(57) **CLAIM**

We claim the ornamental design for an affixable and removable clip, as shown and described.

DESCRIPTION

FIG. 1 is a front left perspective view of an affixable and removable clip showing our new design; FIG. 2 is a front right perspective view thereof; FIG. 3 is a top plan view thereof; FIG. 4 is a bottom plan view thereof; FIG. 5 is a left side view thereof; FIG. 6 is a right side view thereof; FIG. 7 is a front view thereof; FIG. 8 is a rear view thereof; FIG. 9 is a front left perspective view in an exploded format; FIG. 10 is a perspective view of the affixable and removable clip of FIG. 1 in an environment of use; and, FIG. 11 is another perspective view of the affixable and removable clip of FIG. 1 in an environment of use. The broken lines in FIGS. 10 and 11 show environment of the affixable and removable clip that form no part of the claimed design.

(56) **References Cited**

U.S. PATENT DOCUMENTS

1,977,096	A *	10/1934	Straubel	B42F 19/00
					40/342
2,420,021	A *	5/1947	Straubel	B42F 19/00
					40/342
D226,040	S *	1/1973	Beerli, Jr.	D12/177
3,934,368	A *	1/1976	Fearing	A01K 11/001
					40/301
D268,848	S *	5/1983	Lorber	D19/65
4,419,794	A *	12/1983	Horton, Jr.	A45F 5/02
					224/197
4,903,745	A *	2/1990	Roman	A45C 1/04
					150/134
D314,012	S *	1/1991	Klodt	D19/65
D353,221	S *	12/1994	Scott	D26/138

(Continued)

1 Claim, 5 Drawing Sheets

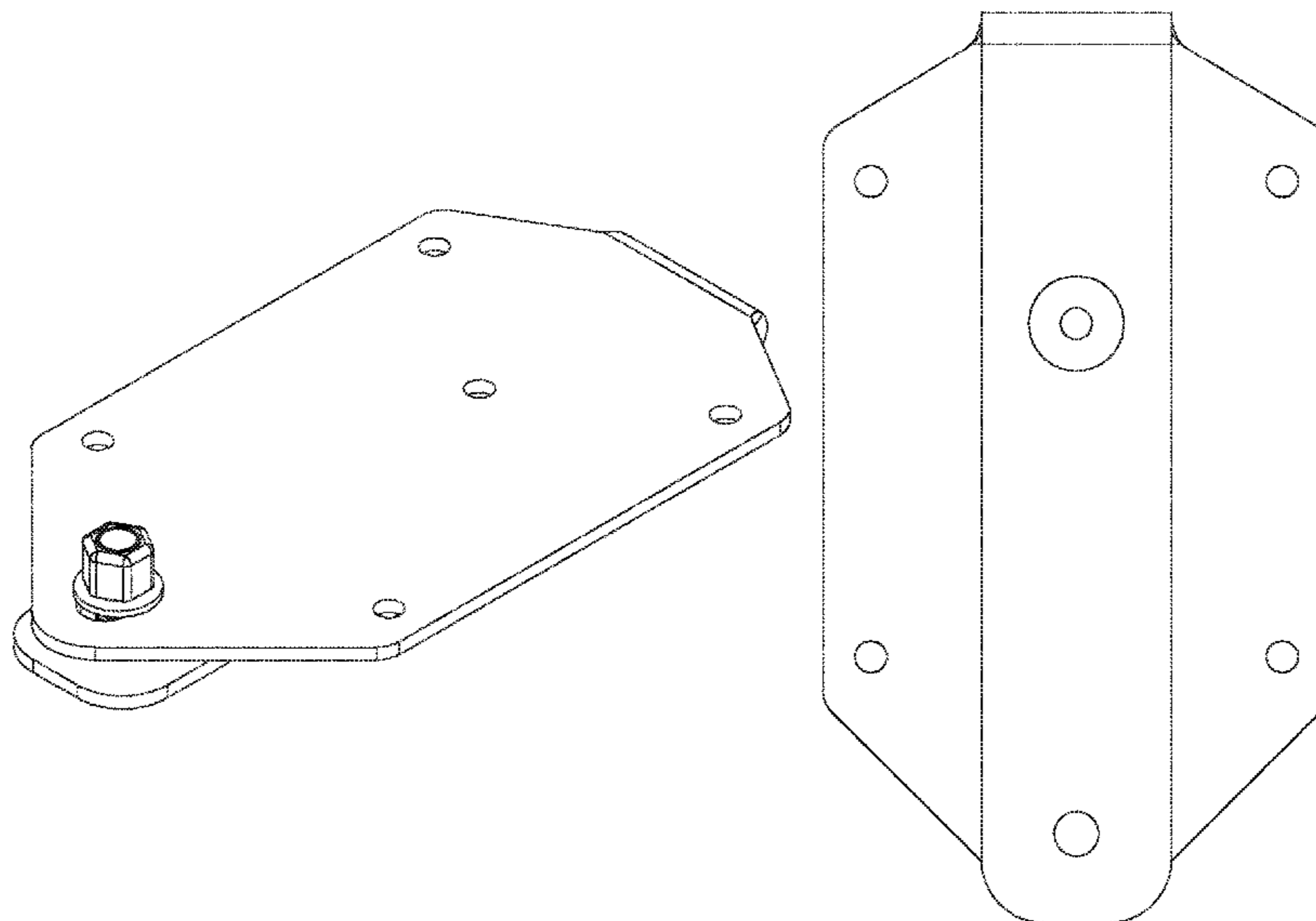

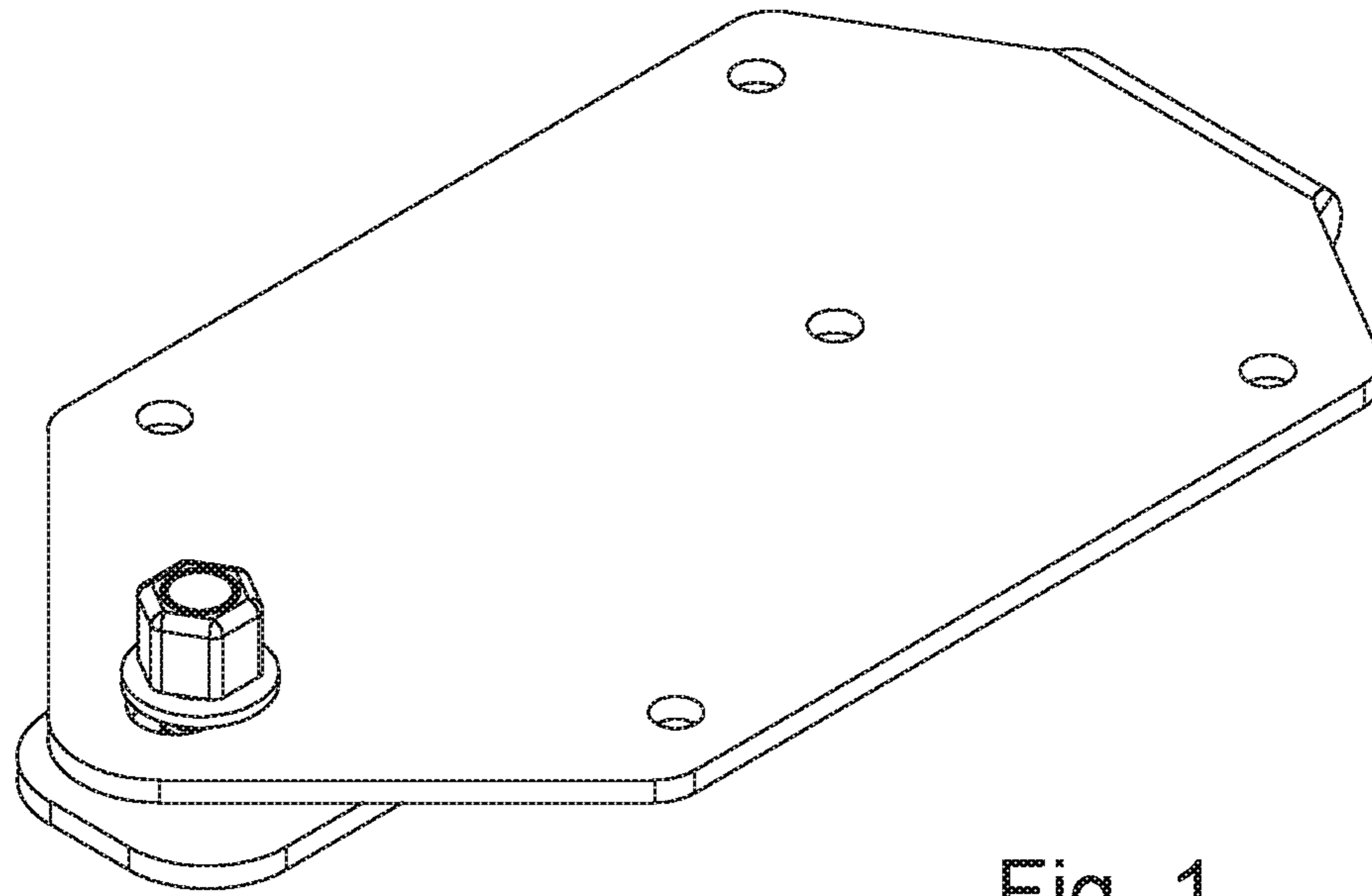

Fig. 1

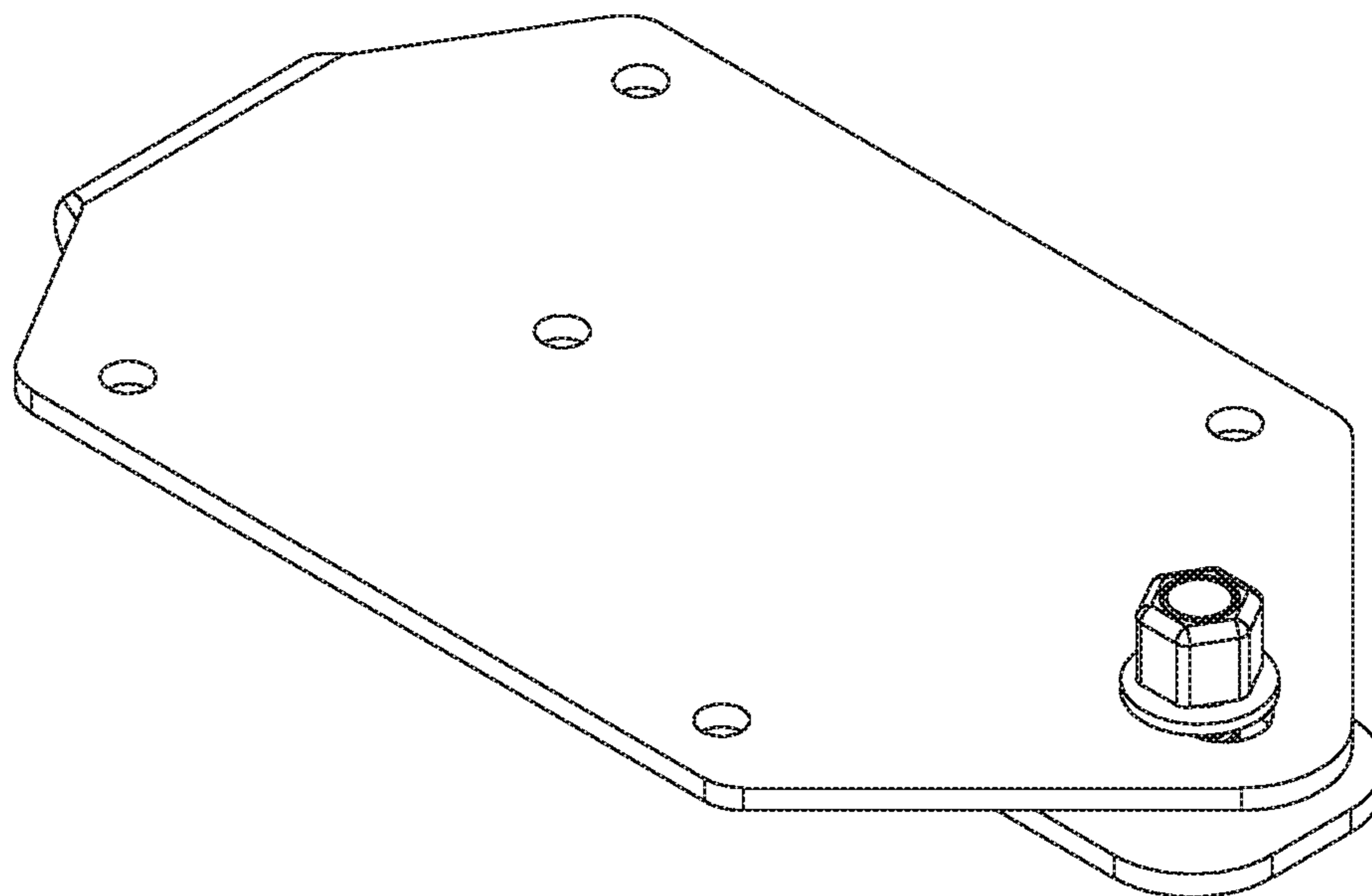

Fig. 2

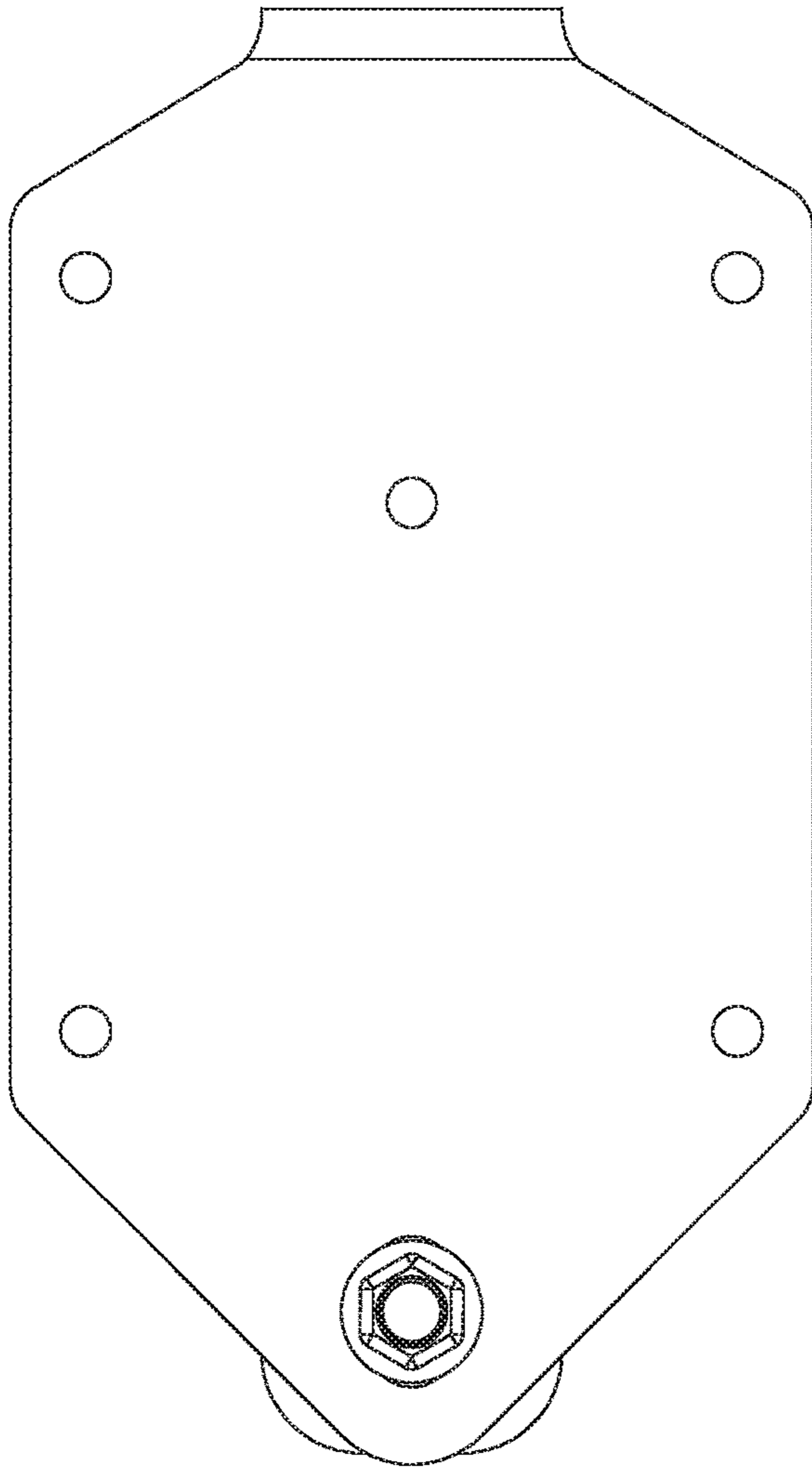

Fig. 3

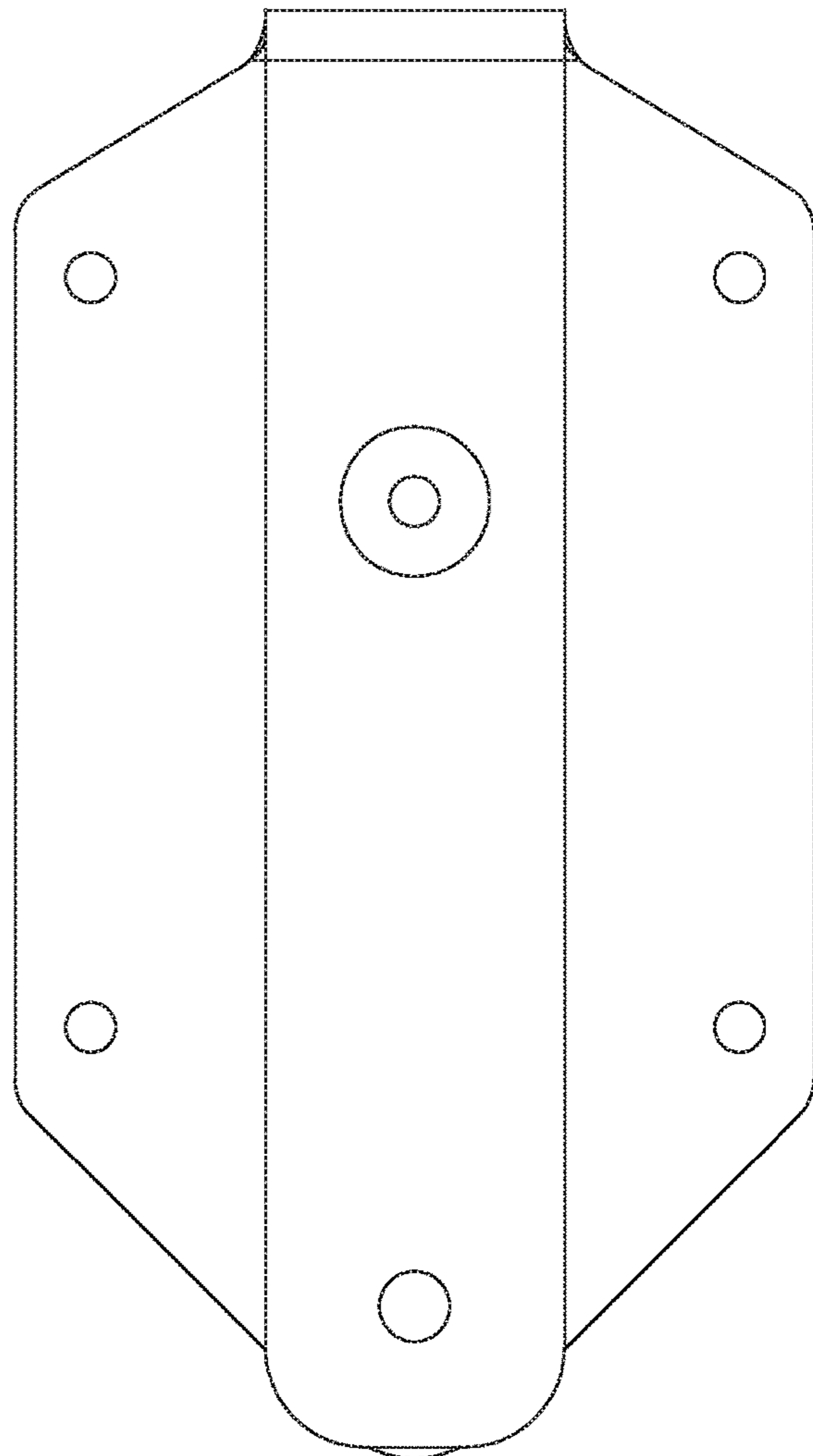

Fig. 4

Fig. 5



Fig. 6

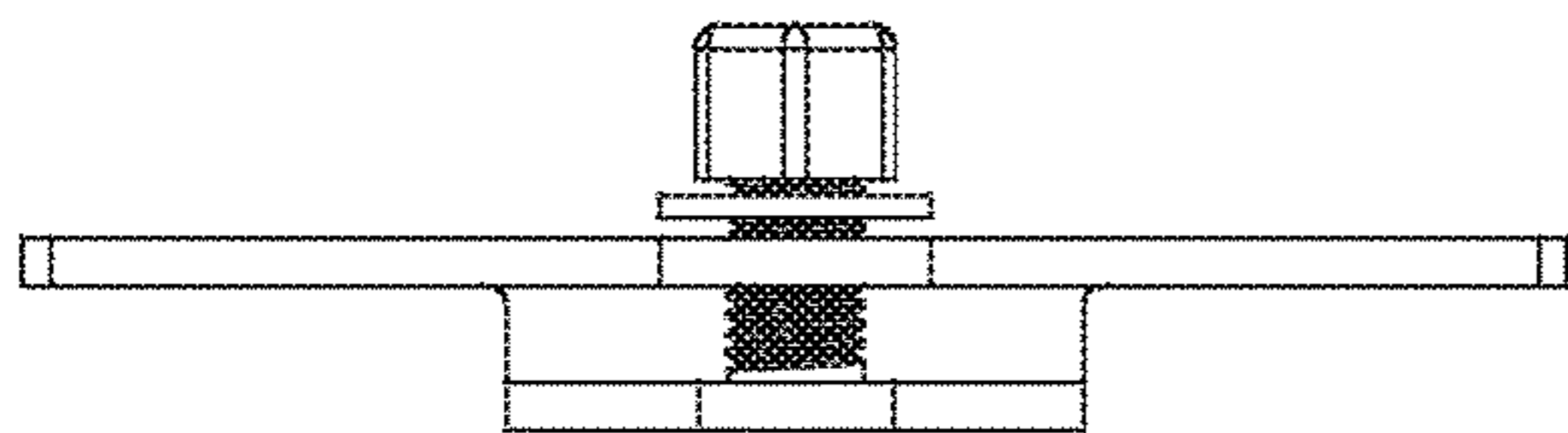
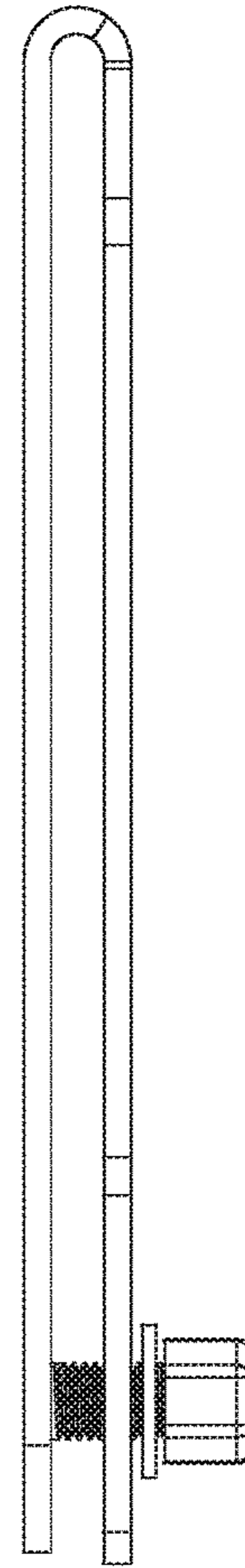

Fig. 7

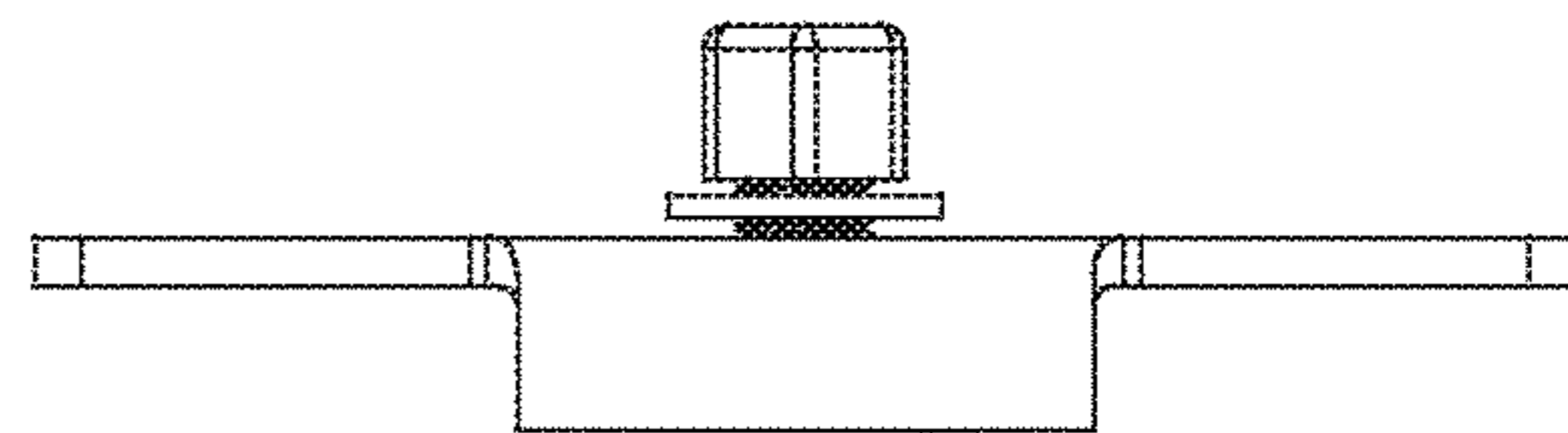

Fig. 8

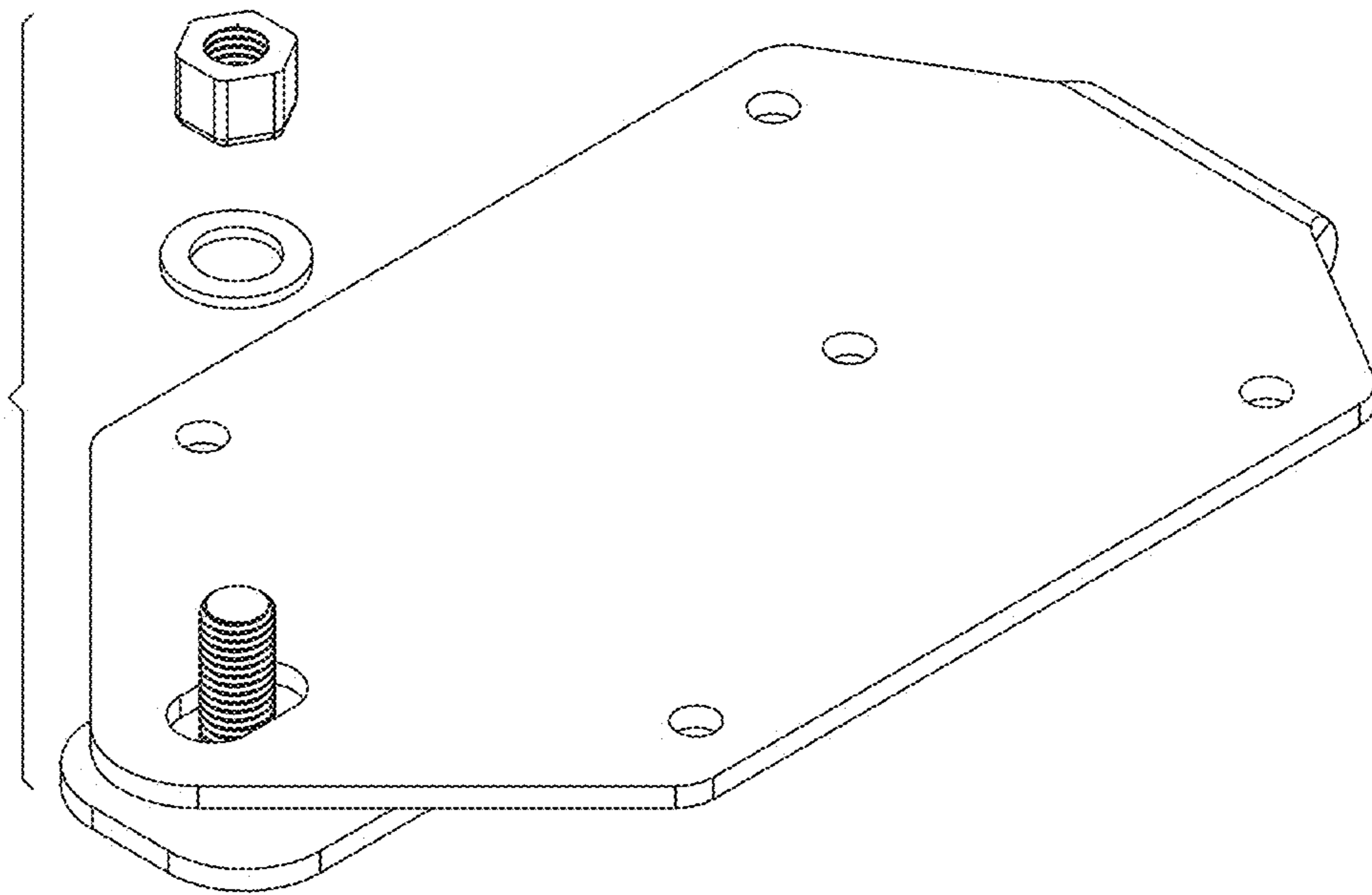

Fig. 9

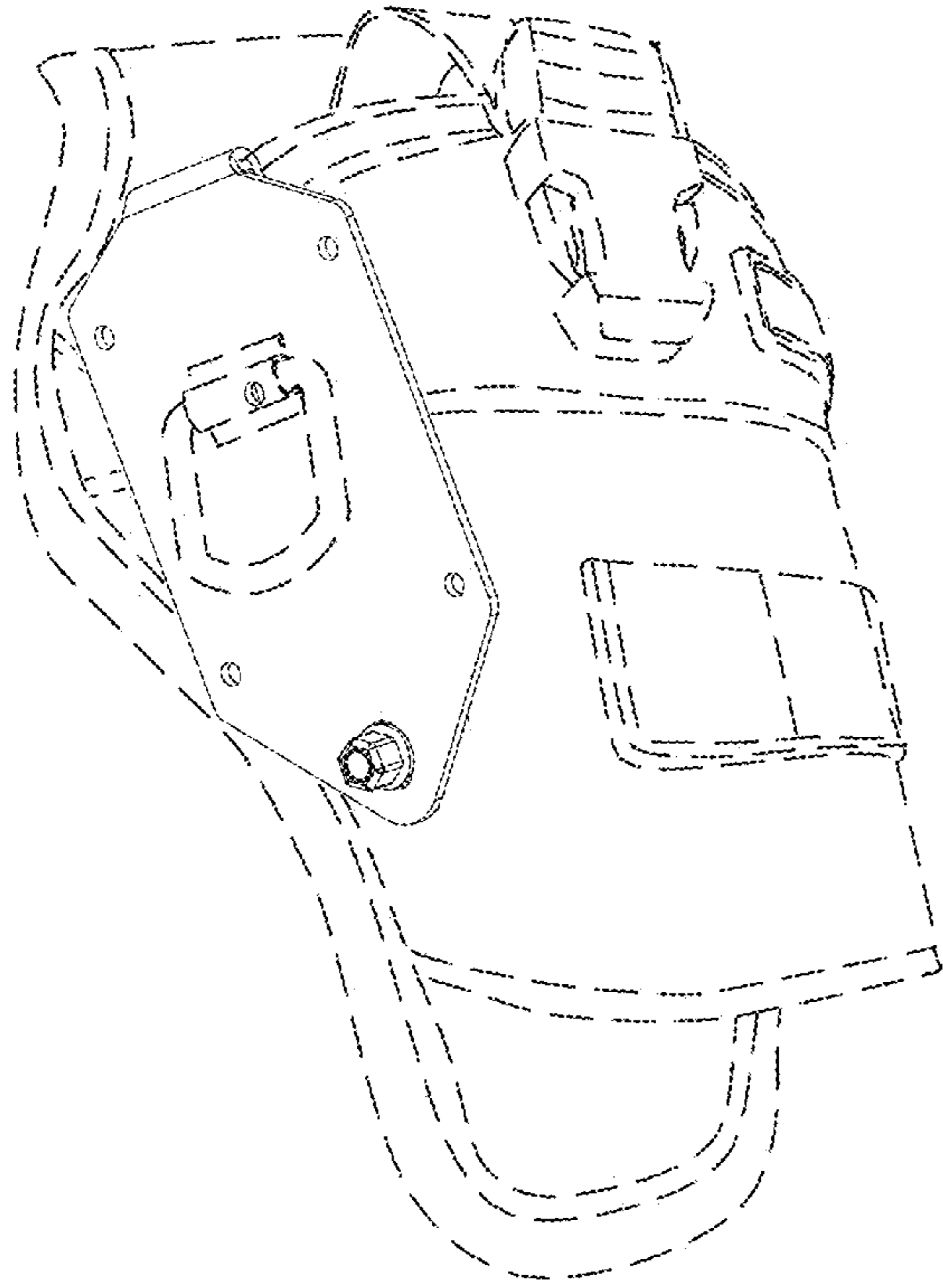

Fig. 10

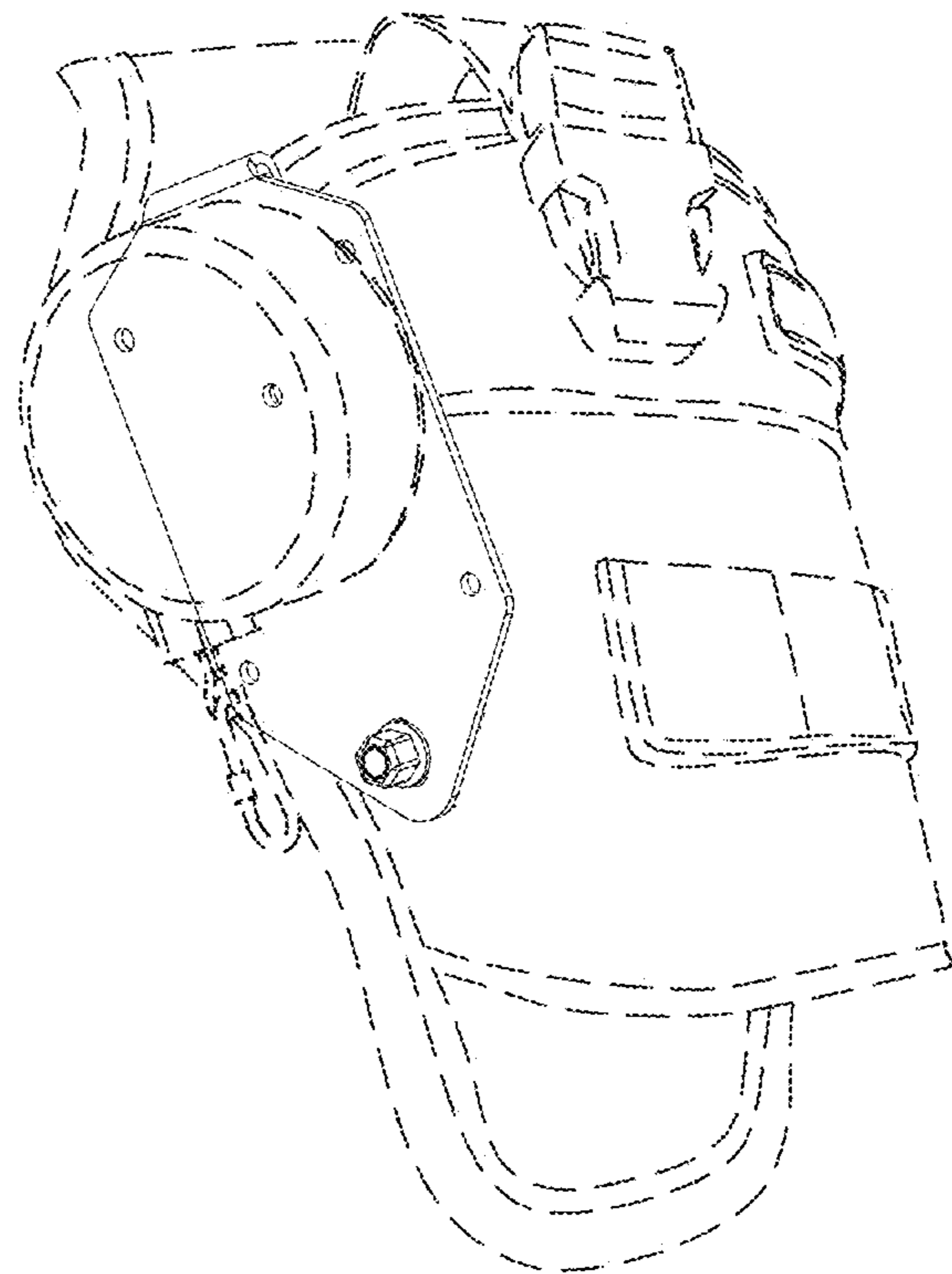

Fig. 11