



US00D867000S

(12) **United States Design Patent**
Liu et al.

(10) **Patent No.:** **US D867,000 S**

(45) **Date of Patent:** **** Nov. 19, 2019**

(54) **FLEXIBLE BOOK STOOL**

(71) Applicant: **Shenzhen Ihpaper Fashion Technology Co. LTD.**, Shenzhen (CN)

(72) Inventors: **Jianghua Liu**, Shenzhen (CN); **Xiao Li**, Shenzhen (CN)

(73) Assignee: **SHENZHEN IHPAPER FASHION TECHNOLOGY CO. LTD.**, Shenzhen (CN)

(**) Term: **15 Years**

(21) Appl. No.: **29/642,882**

(22) Filed: **Apr. 3, 2018**

(51) **LOC (12) Cl.** **06-01**

(52) **U.S. Cl.**
USPC **D6/352; D6/353**

(58) **Field of Classification Search**
USPC D6/334-338, 340-343, 349-353, 355,
D6/364-365, 691-691.9, 692-692.6;
D25/65
CPC A47B 7/00-02; A47C 11/00; A47C 13/00;
A47C 16/00; A47C 16/02-04; A47C
9/00-105; A47C 17/02; A47C 17/028
See application file for complete search history.

(56) **References Cited**

U.S. PATENT DOCUMENTS

- 2,807,405 A * 9/1957 Lambert B65D 3/22
229/117.01
- D216,012 S * 11/1969 Buchsbaum D6/352
- D260,214 S * 8/1981 Lewis D6/692.3
- D369,319 S * 4/1996 Weder D11/152
- D370,138 S * 5/1996 Rosebrock D6/349
- D651,818 S * 1/2012 Omori D6/349
- D727,555 S * 4/2015 Gunawan D26/94

(Continued)

OTHER PUBLICATIONS

White mini stool. [online] Published Dec. 10, 2015. Retrieved from URL: https://www.youtube.com/watch?v=_nPh4oqUL2o.*

(Continued)

Primary Examiner — Vy N Koenig

(74) *Attorney, Agent, or Firm* — Arc IP Law, PC; Joseph J. Mayo

(57) **CLAIM**

The ornamental design for a flexible book stool, as shown and described.

DESCRIPTION

FIG. 1 is a perspective view of the flexible book stool, with the collapsible part and the seat cushion separated and both in a folded configuration.

FIG. 2 is a perspective view of the flexible book stool, with the collapsible part in a semi-deployed configuration and without the seat cushion thereon.

FIG. 3 is a perspective view of the flexible book stool, with the collapsible part in a deployed configuration and without the seat cushion thereon.

FIG. 4 is a perspective view of the flexible book stool, with the collapsible part in a deployed configuration and with the seat cushion thereon.

FIG. 5 is a perspective view of the flexible book stool, with the collapsible part in a folded configuration and the seat cushion deployed.

FIG. 6 is a perspective view of the flexible book stool, with the collapsible part in a folded configuration and the seat cushion folded over the collapsible part.

FIG. 7 is a front view of the flexible book stool of FIG. 6, of which the back view is a mirror image thereof.

FIG. 8 is a right-side view of the flexible book stool of FIG. 6.

FIG. 9 is a left-side view of the flexible book stool of FIG. 6; and,

FIG. 10 is a top view of the flexible book stool of FIG. 6, of which the bottom view is a mirror image thereof.

1 Claim, 10 Drawing Sheets

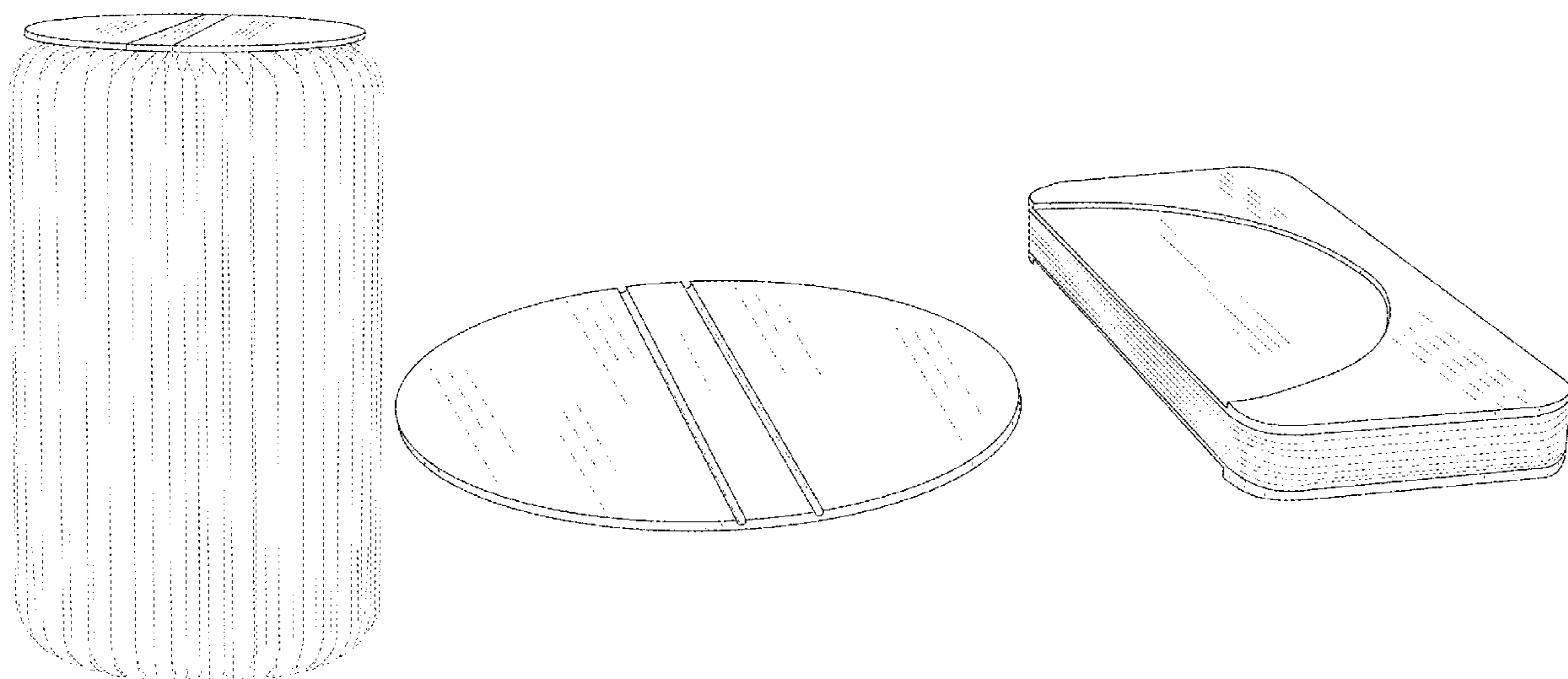

(56)

References Cited

U.S. PATENT DOCUMENTS

D734,666 S * 7/2015 Blonder D9/430
D756,555 S * 5/2016 Gunawan D26/94
D759,195 S * 6/2016 Tanida D23/209
D794,344 S * 8/2017 MacAllen D6/335
D808,695 S * 1/2018 MacAllen D6/692.3
D810,452 S * 2/2018 Gu D6/352
2009/0078838 A1 * 3/2009 Chang A45B 3/00
248/188.6

OTHER PUBLICATIONS

28cm Height ihpaper self-designed folding paper stool. [online]
Retrieved Mar. 4, 2019 from URL: https://ihpaper.en.alibaba.com/product/60703805880-802426324/28cm_Height_ihpaper_self_designed_folding_paper_stool_room_chairs.html.*

FlexYah Stool_2x Ultra Compact folding Seats . [online] Published
on Oct. 29, 2018. Retrieved Mar. 4, 2019 from URL: https://expandfurniture.com/product/flexyah-stool-2x-ultra-compact-folding-seats/?attribute_pa_colors=earth&gclid=Cj0KCQiAtvPjBRDPARIsAJfZz0pM-Q2ERs5-Wj1dgXOdLKmxf9LpCf12cOQtA-89U-OxFA6BW7XGUzkaAog2EALw_wcB.*

OLizee Portable Folding Stools Kraft Paper Stools. [online] Pub-
lished on Jan. 15, 2018. Retrieved Mar. 4, 2019 from URL:
<https://www.amazon.com/OLizee-Portable-Folding-Artificial-Cushion/dp/B014ZZXEL2>.*

* cited by examiner

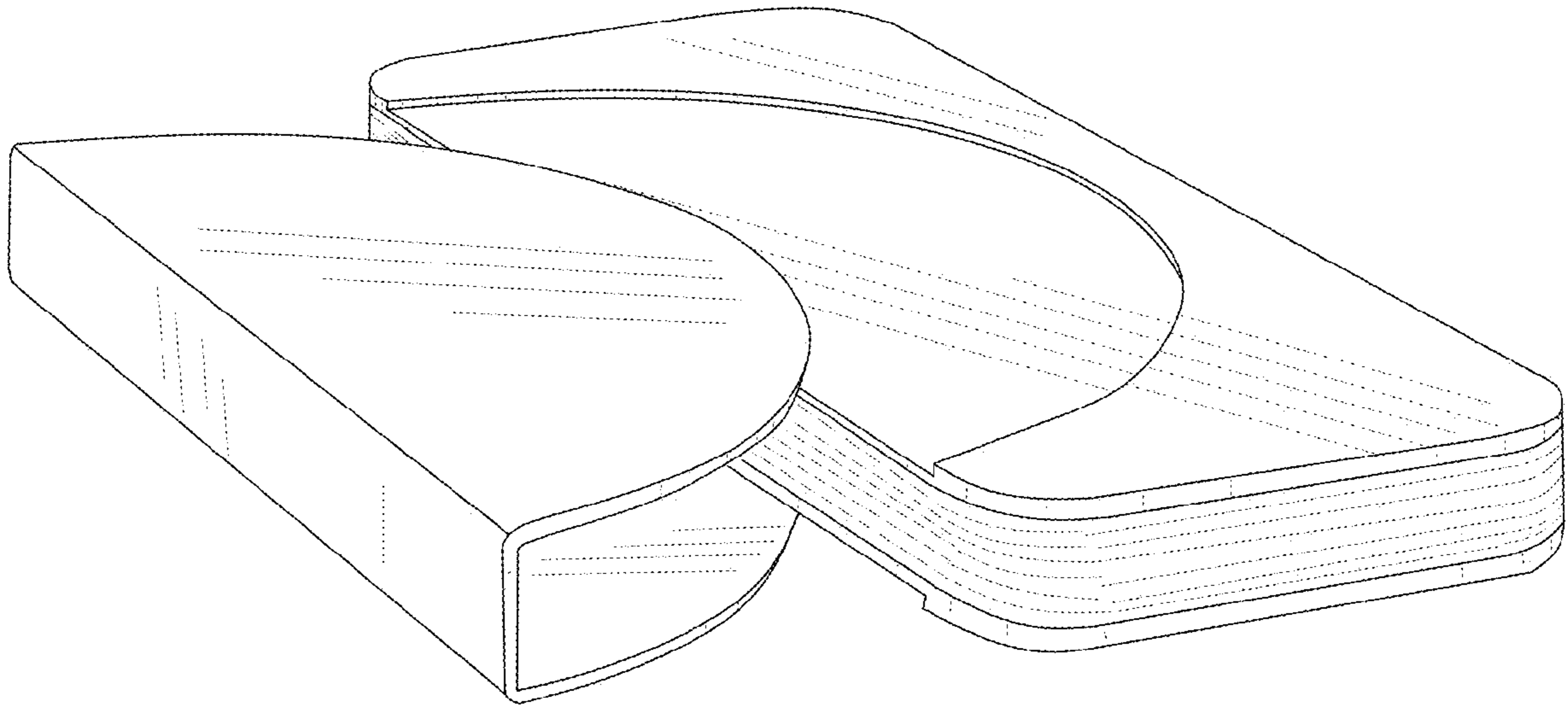

Fig. 1

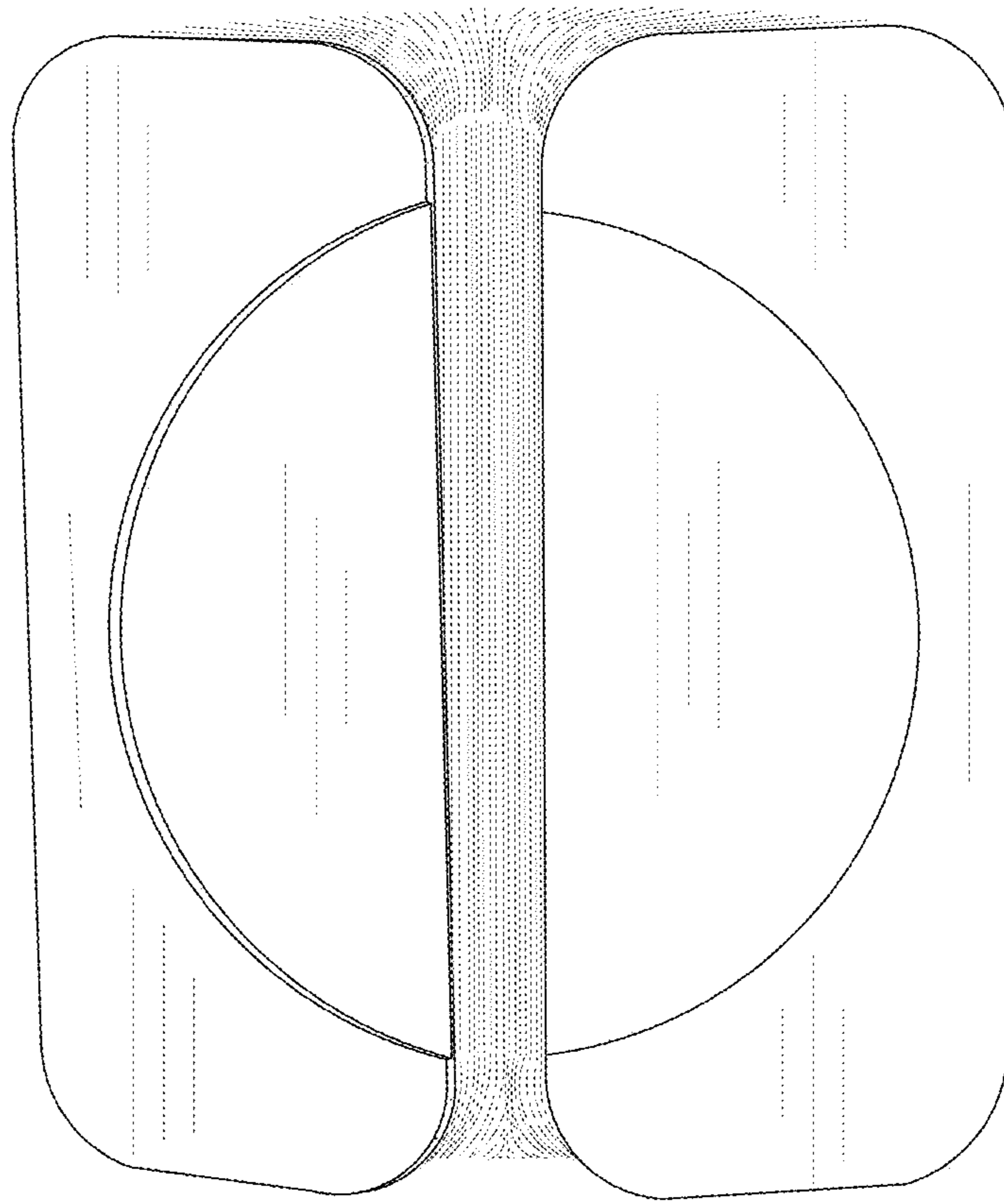

Fig.2

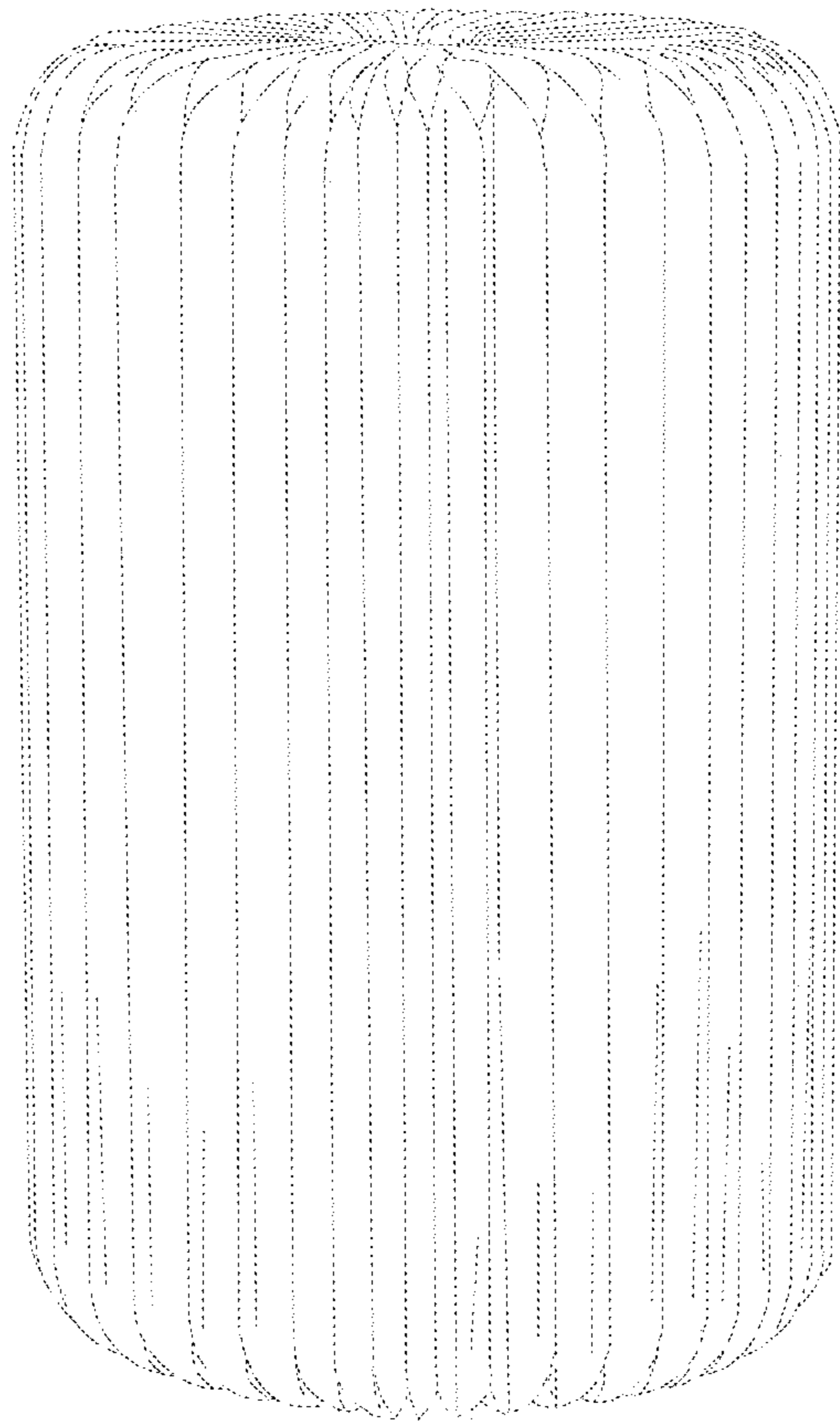

Fig. 3

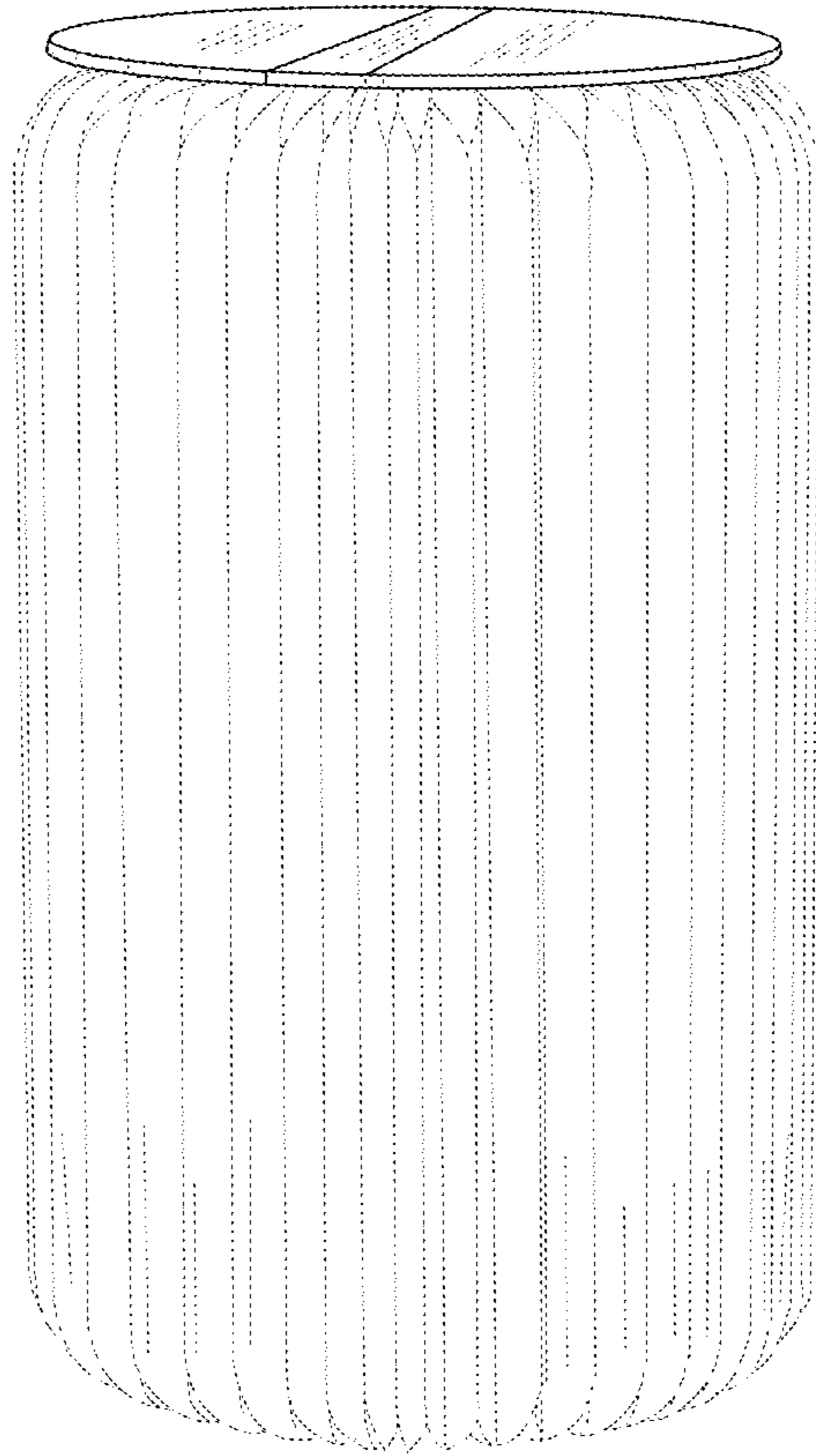

Fig.4

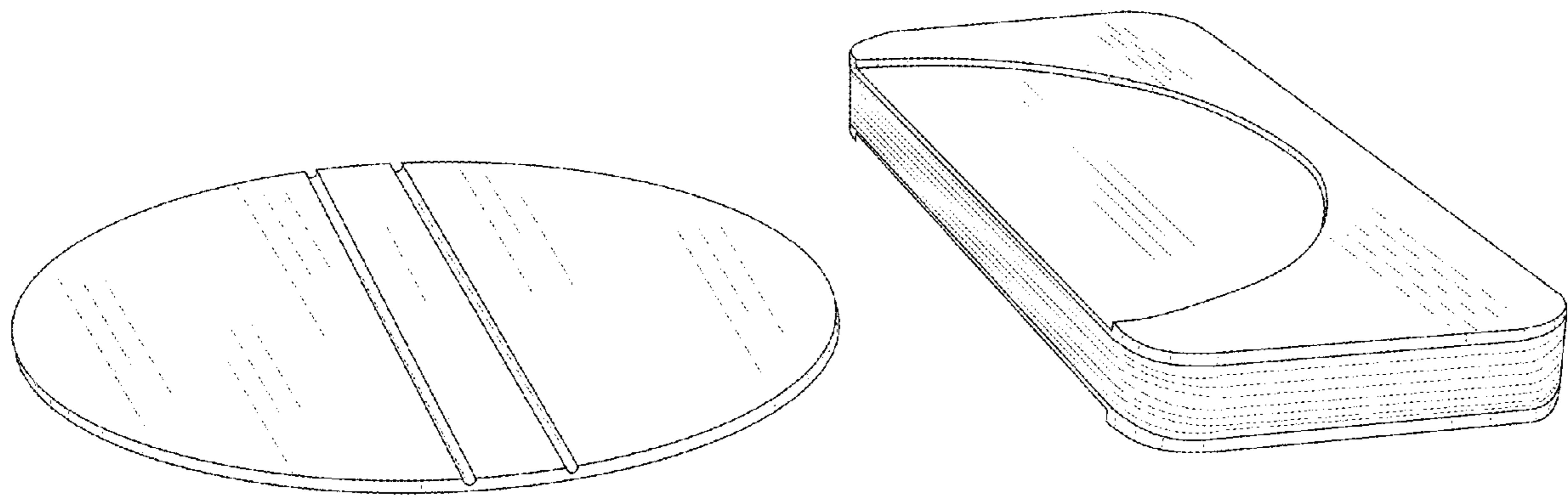

Fig.5

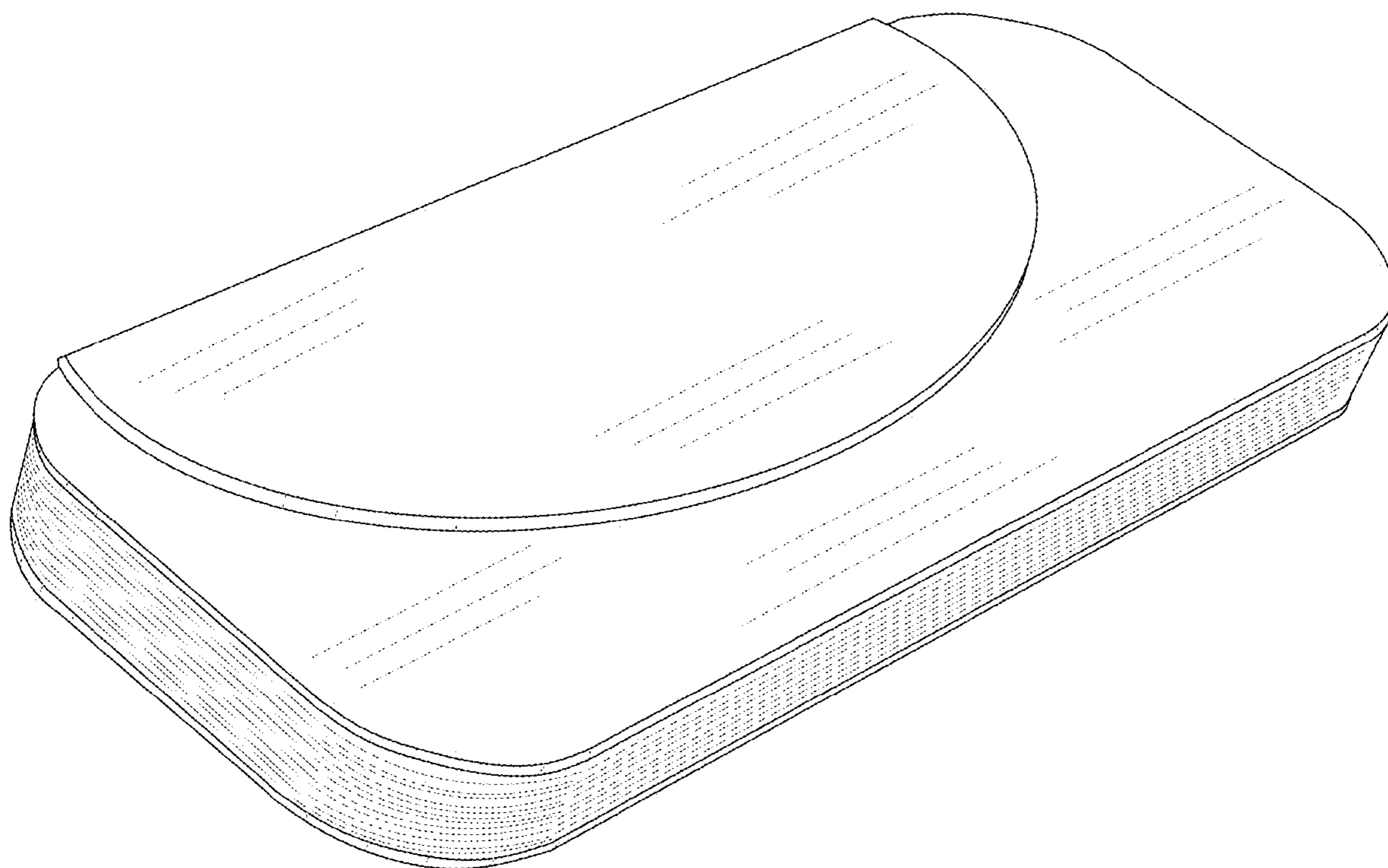

Fig.6

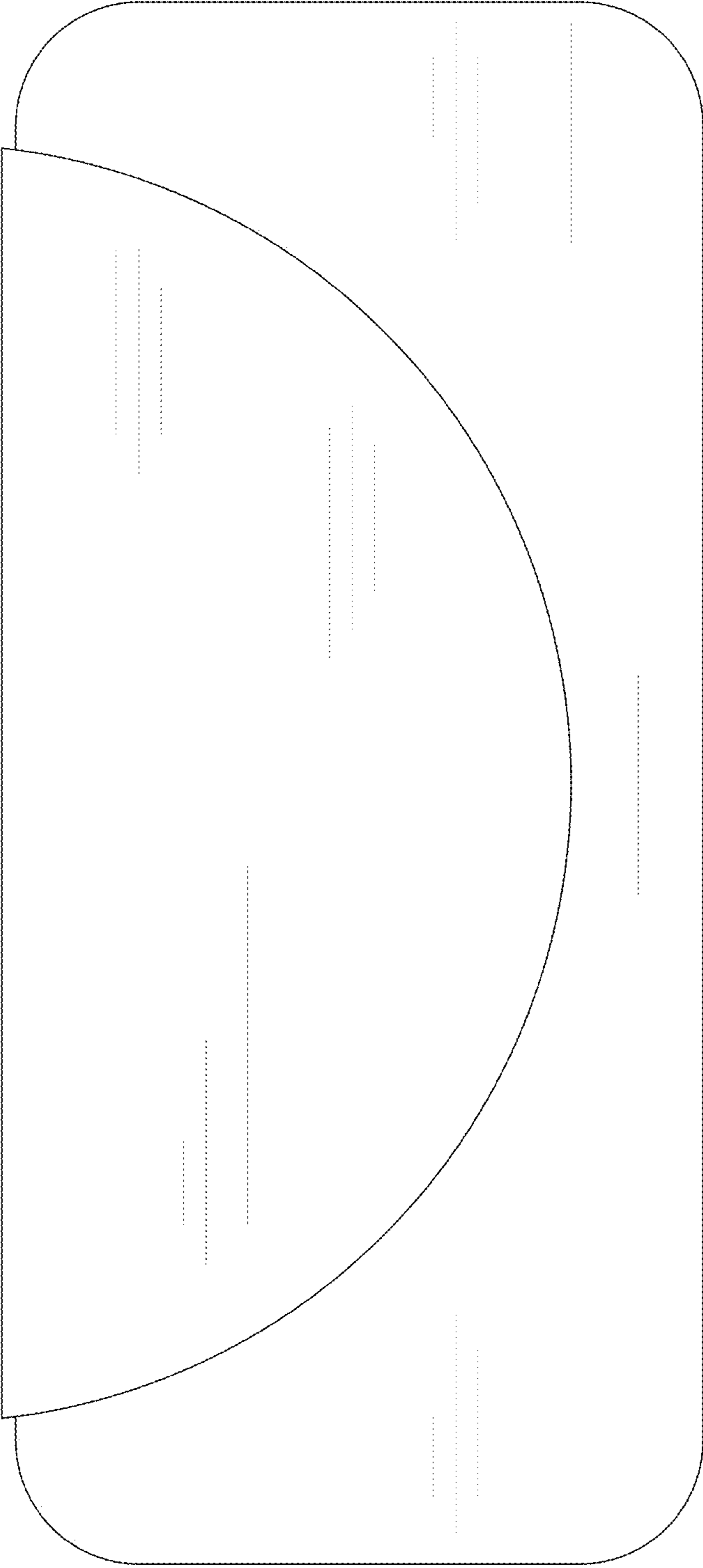

Fig. 7

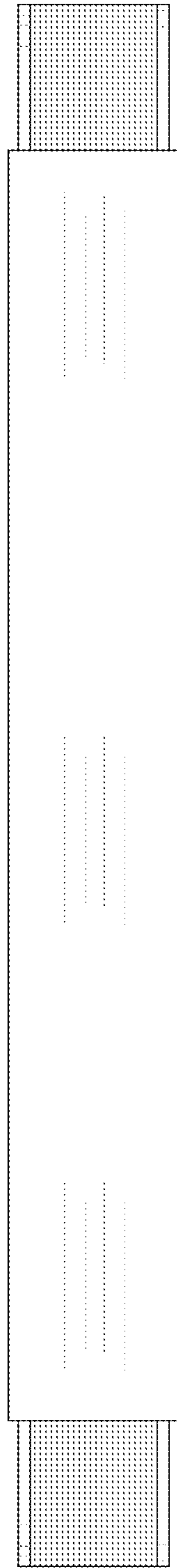

Fig. 8

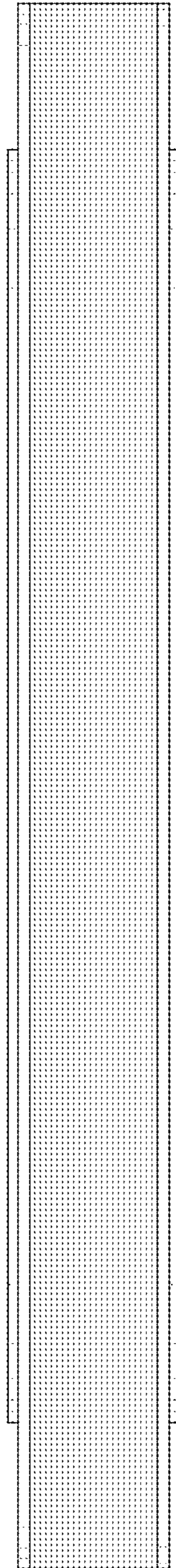

Fig.9

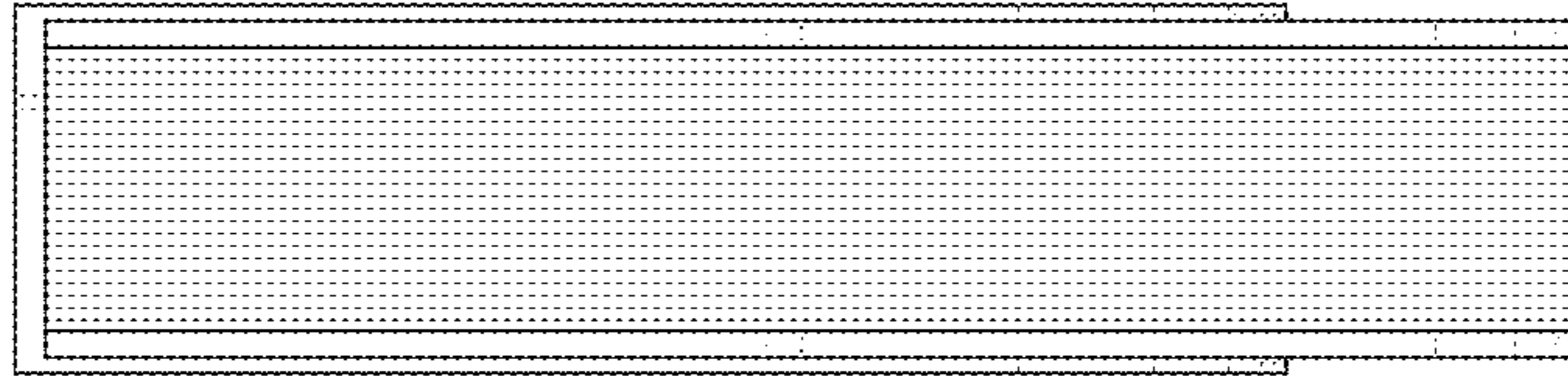

Fig. 10