



US00D866675S

(12) **United States Design Patent** (10) **Patent No.:** **US D866,675 S**
Desberg (45) **Date of Patent:** **** Nov. 12, 2019**

(54) **SCOOTER**

FOREIGN PATENT DOCUMENTS

(71) Applicant: **RAZOR USA LLC**, Cerritos, CA (US)

DE 19711042 A1 9/1998
FR 0396141 4/1909

(72) Inventor: **Ian Desberg**, Cerritos, CA (US)

(Continued)

(73) Assignee: **RAZOR USA LLC**, Cerritos, CA (US)

OTHER PUBLICATIONS

(**) Term: **15 Years**

Dirt King, "Declaration of James R. Funk", —Alleged public use and service in 1985; drawings and xerographic copies of photographs, Dec. 14, 2000.

(21) Appl. No.: **29/674,371**

(Continued)

(22) Filed: **Dec. 20, 2018**

Related U.S. Application Data

Primary Examiner — Cynthia M. Chin

(63) Continuation of application No. 29/643,133, filed on Apr. 4, 2018, now Pat. No. Des. 837,303, which is a continuation of application No. 29/577,036, filed on Sep. 8, 2016, now Pat. No. Des. 815,215.

(74) *Attorney, Agent, or Firm* — Knobbe, Martens, Olson & Bear, LLP

(51) **LOC (12) Cl.** **21-01**

(57) **CLAIM**

(52) **U.S. Cl.**

The ornamental design for a scooter, as shown and described.

USPC **D21/423**

(58) **Field of Classification Search**

DESCRIPTION

USPC D21/419, 421, 423, 426–428, 435,
D21/668–671, 760, 765, 771; D12/1, 8,
D12/108, 111, 112, 113

CPC . B62K 3/002; B62K 9/00; B62K 9/02; B62K
13/00; B62K 2202/00

See application file for complete search history.

FIG. 1 is a top, rear, left-side perspective view showing a scooter of my design;
FIG. 2 is a close-up view of a portion thereof;
FIG. 3 is a bottom, front, left-side view thereof;
FIG. 4 is a left-side view thereof;
FIG. 5 is a right-side view thereof;
FIG. 6 is a front view thereof;
FIG. 7 is a rear view thereof;
FIG. 8 is a top view thereof; and,
FIG. 9 is a bottom view thereof.

(56) **References Cited**

U.S. PATENT DOCUMENTS

606,525 A 6/1898 Dunning
628,433 A 7/1899 Finch
730,622 A 6/1903 Milton
1,297,282 A 3/1919 White
1,345,038 A 6/1920 Uppling
1,391,312 A 9/1921 Gebhardt
1,534,601 A 4/1925 Matveyeff
1,570,189 A 1/1926 Sturm
1,614,822 A 1/1927 Bukolt
1,653,558 A 12/1927 Fisher

The dot-dash line in FIG. 2 represents the boundary of the enlarged partial view. All other broken lines are for the purpose of illustrating portions of the scooter that form no part of the claimed design. None of the broken lines form a part of the claimed design.

(Continued)

1 Claim, 8 Drawing Sheets

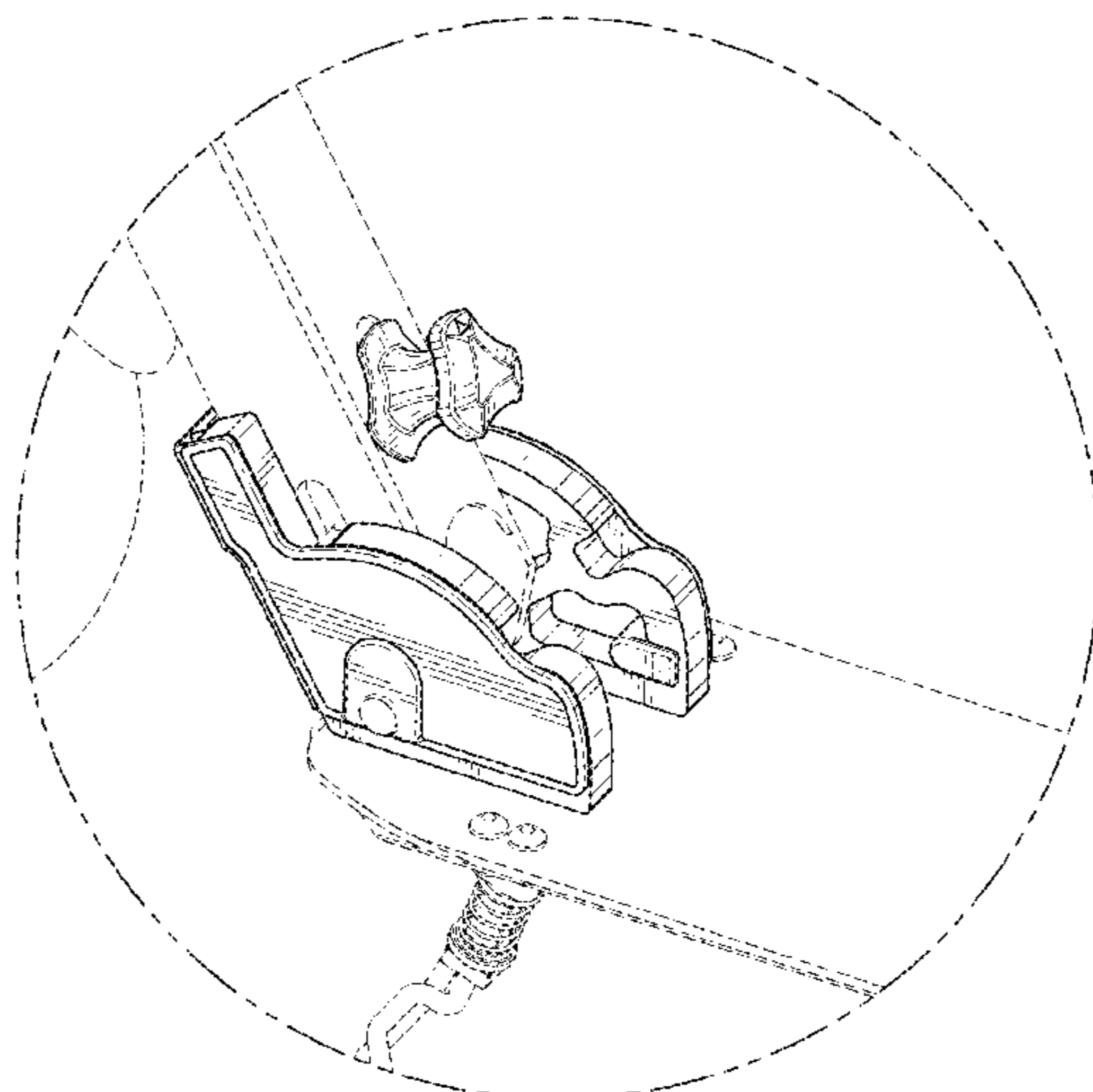

(56)

References Cited

U.S. PATENT DOCUMENTS

1,658,068 A 2/1928 White
 1,687,739 A 10/1928 Slusher
 1,687,953 A 10/1928 Starks
 1,701,410 A 2/1929 Hornquist
 1,714,000 A 5/1929 Davis
 1,968,975 A 8/1934 Upsacker et al.
 2,198,667 A 4/1940 Hagenes
 2,439,556 A 4/1948 Bancroft
 2,460,395 A 2/1949 Reid
 2,546,711 A 3/1951 Amendt
 3,006,659 A 10/1961 Krasnoff
 3,288,251 A 11/1966 Paul
 3,396,928 A 8/1968 Lay
 3,484,116 A 12/1969 Allen
 3,684,305 A 8/1972 Mcdonald
 3,876,217 A 4/1975 Henri
 3,891,225 A 6/1975 Sessa
 4,003,582 A 1/1977 Maurer
 4,033,596 A 7/1977 Andorsen
 4,088,334 A 5/1978 Johnson
 4,102,541 A 7/1978 Altorfer et al.
 4,103,917 A 8/1978 Widolf
 4,144,822 A 3/1979 Roberts et al.
 4,166,629 A 9/1979 List
 4,169,687 A 10/1979 Schull
 4,179,134 A 12/1979 Atkinson
 4,202,559 A 5/1980 Piazza, Jr.
 4,394,029 A 7/1983 Holmgren
 4,584,735 A 4/1986 Garber
 4,707,884 A 11/1987 Chang
 4,735,392 A 4/1988 Farmer
 4,790,550 A 12/1988 Simpson
 4,795,181 A 1/1989 Armstrong
 4,799,701 A 1/1989 Lindau
 4,905,946 A 3/1990 Wang
 5,042,622 A 8/1991 Smith
 5,102,079 A 4/1992 Lee
 5,183,129 A 2/1993 Powell
 5,192,099 A 3/1993 Riutta
 5,238,082 A 8/1993 Stegeman et al.
 5,320,367 A 6/1994 Landis
 5,383,536 A 1/1995 Butter et al.
 5,437,425 A 8/1995 Hou
 5,630,633 A 5/1997 Dupre et al.
 5,692,761 A 12/1997 Havlovitz
 5,816,614 A 10/1998 Kramer, Jr. et al.
 5,848,660 A 12/1998 McGreen
 5,927,733 A 7/1999 Banda
 5,938,223 A 8/1999 Kotlier
 5,992,566 A 11/1999 Yeh
 6,120,044 A 9/2000 Tsai
 6,139,035 A 10/2000 Tsai
 D435,873 S 1/2001 Lee
 6,179,307 B1 1/2001 Mao
 6,182,988 B1 2/2001 Wu
 D438,912 S 3/2001 Barrera
 D439,623 S 3/2001 Barrera
 6,206,387 B1 3/2001 Tsai
 6,234,501 B1 5/2001 Chen
 D446,259 S 8/2001 Udwin et al.
 D447,187 S 8/2001 Powers
 6,270,095 B1 * 8/2001 Chang B62K 3/002
 280/87.041
 6,276,701 B1 8/2001 Chen
 6,298,952 B1 10/2001 Tsai
 D452,284 S 12/2001 McGinnis

6,332,621 B1 * 12/2001 Wu B62K 3/002
 16/900
 6,378,880 B1 4/2002 Lin
 6,390,483 B1 5/2002 Hsu et al.
 6,409,190 B1 6/2002 Tsai
 6,428,021 B1 8/2002 Tung
 6,431,567 B2 8/2002 Tsai
 7,011,319 B2 3/2006 Lu
 7,063,341 B2 6/2006 Tsai
 7,156,405 B1 1/2007 Ming
 7,407,172 B2 * 8/2008 Ka Ming B62K 3/002
 280/87.041
 7,419,171 B1 * 9/2008 Ka Ming B62K 3/002
 280/87.041
 7,559,561 B2 7/2009 Tsai
 7,584,974 B2 9/2009 Jackman
 7,976,035 B2 7/2011 Chan
 D654,963 S 2/2012 Powers et al.
 8,157,275 B2 4/2012 Tsai
 8,292,018 B2 10/2012 Huang
 D671,600 S 11/2012 Horne
 D684,217 S 6/2013 Hadley
 8,474,840 B2 7/2013 Tsai
 D691,671 S 10/2013 Chen et al.
 D692,963 S 11/2013 Radtke et al.
 8,870,200 B2 10/2014 Chen
 D717,881 S 11/2014 Radtke et al.
 8,925,935 B2 1/2015 Powers et al.
 8,998,224 B2 * 4/2015 Ngai B60B 19/00
 280/87.041
 9,422,021 B2 8/2016 Tsai
 9,862,449 B2 * 1/2018 Xu B62K 3/002
 D815,215 S 4/2018 Desberg
 D818,541 S * 5/2018 Huang D21/423
 9,969,456 B2 5/2018 Tsai
 10,093,380 B2 * 10/2018 Gotfrid B62K 15/006
 D836,727 S * 12/2018 Wilson D21/423
 D837,303 S 1/2019 Desberg
 2002/0050696 A1 * 5/2002 Lan B62K 3/002
 280/87.041
 2002/0093161 A1 7/2002 Udwin et al.
 2003/0067132 A1 * 4/2003 Lin B62K 3/002
 280/87.041
 2004/0129472 A1 7/2004 Cheng
 2005/0073121 A1 4/2005 Chen
 2006/0103096 A1 5/2006 Chen
 2009/0230648 A1 9/2009 Chan
 2009/0278327 A1 * 11/2009 Chan B62K 3/002
 280/87.05
 2013/0087983 A1 4/2013 Ngai
 2013/0320648 A1 12/2013 Eckert et al.
 2018/0065702 A1 3/2018 Desberg

FOREIGN PATENT DOCUMENTS

GB 699673 A 11/1953
 WO WO 2018/045218 A1 3/2018

OTHER PUBLICATIONS

Sharper Image Catalogue, Aug. 1998.
 Xerographic copy of photographs or advertisements relating to
 "K2"scooter, date unknown.
 Xerographic copy photos or advertisements relating to "Rollerboard"
 scooter, date unknown.
 Tranz X drawings, 1998.

* cited by examiner

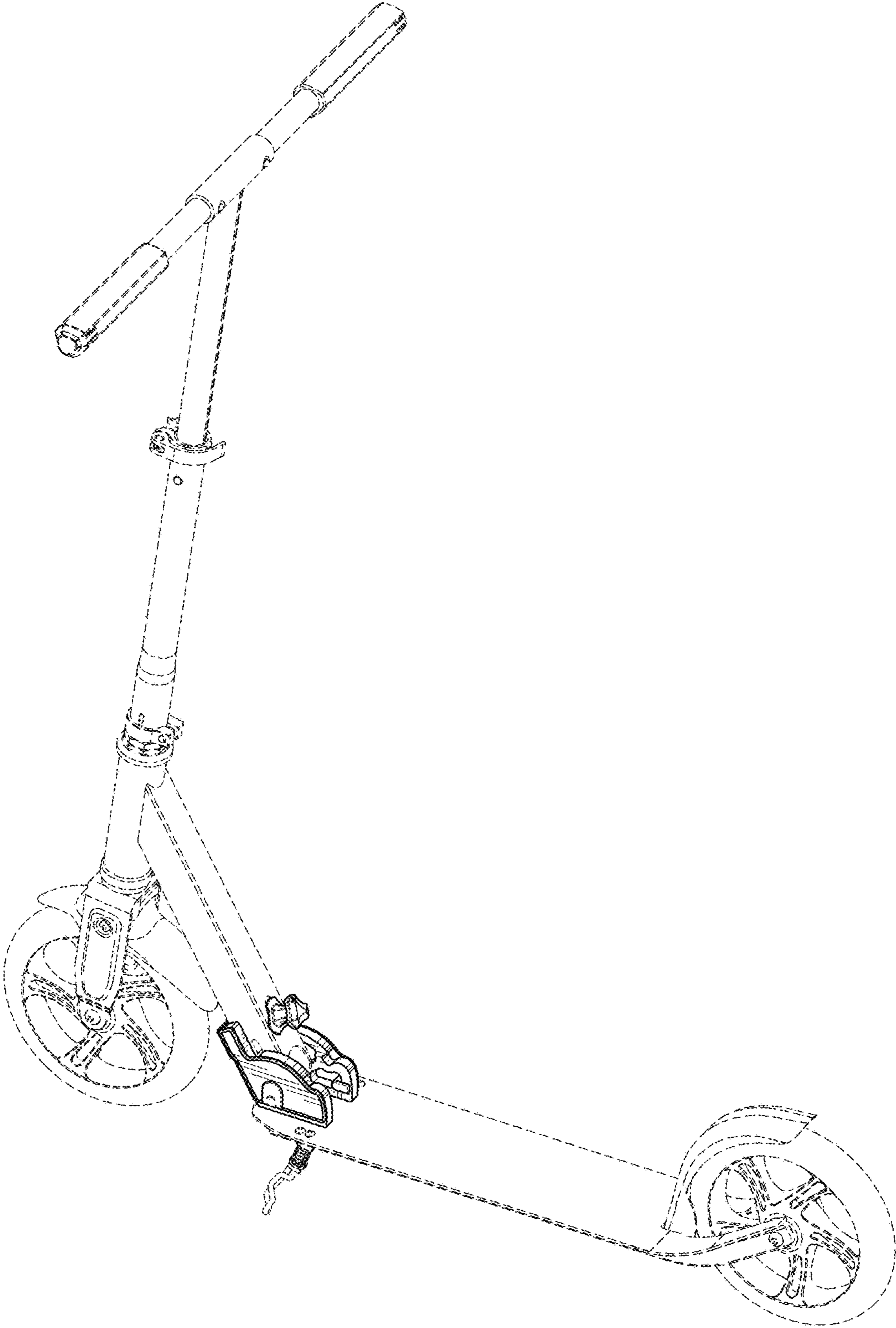

FIG. 1

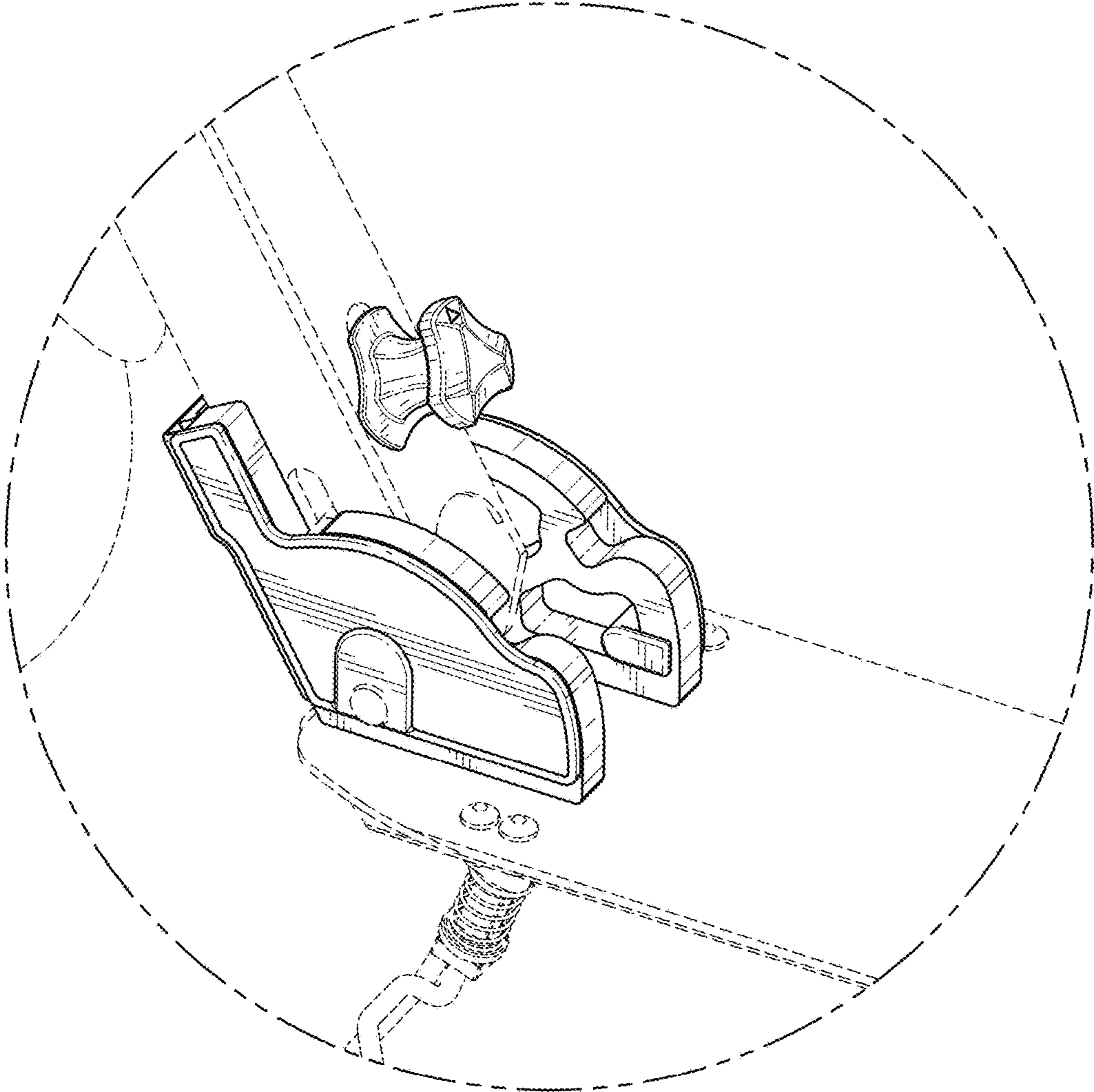

FIG. 2

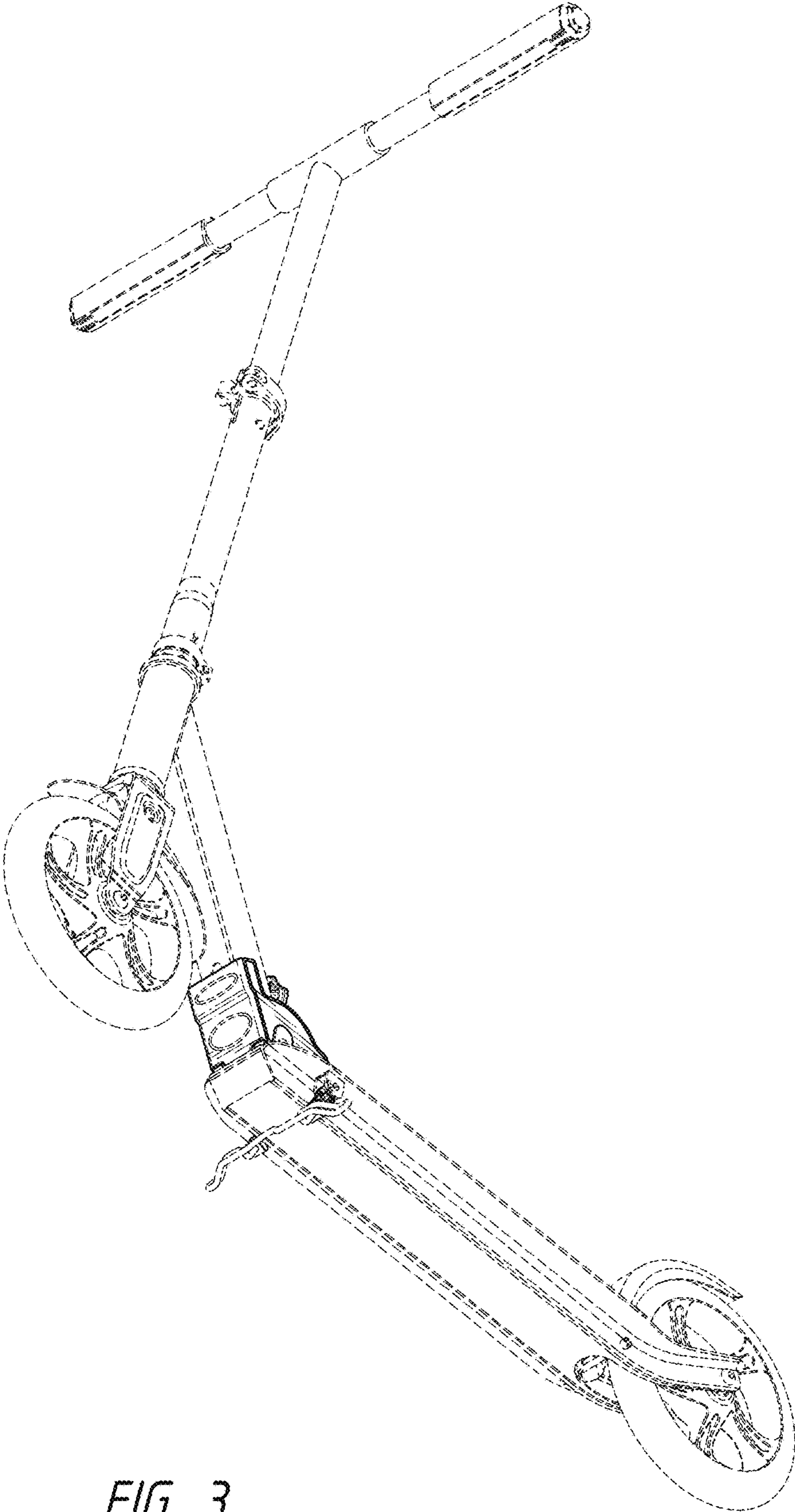

FIG. 3

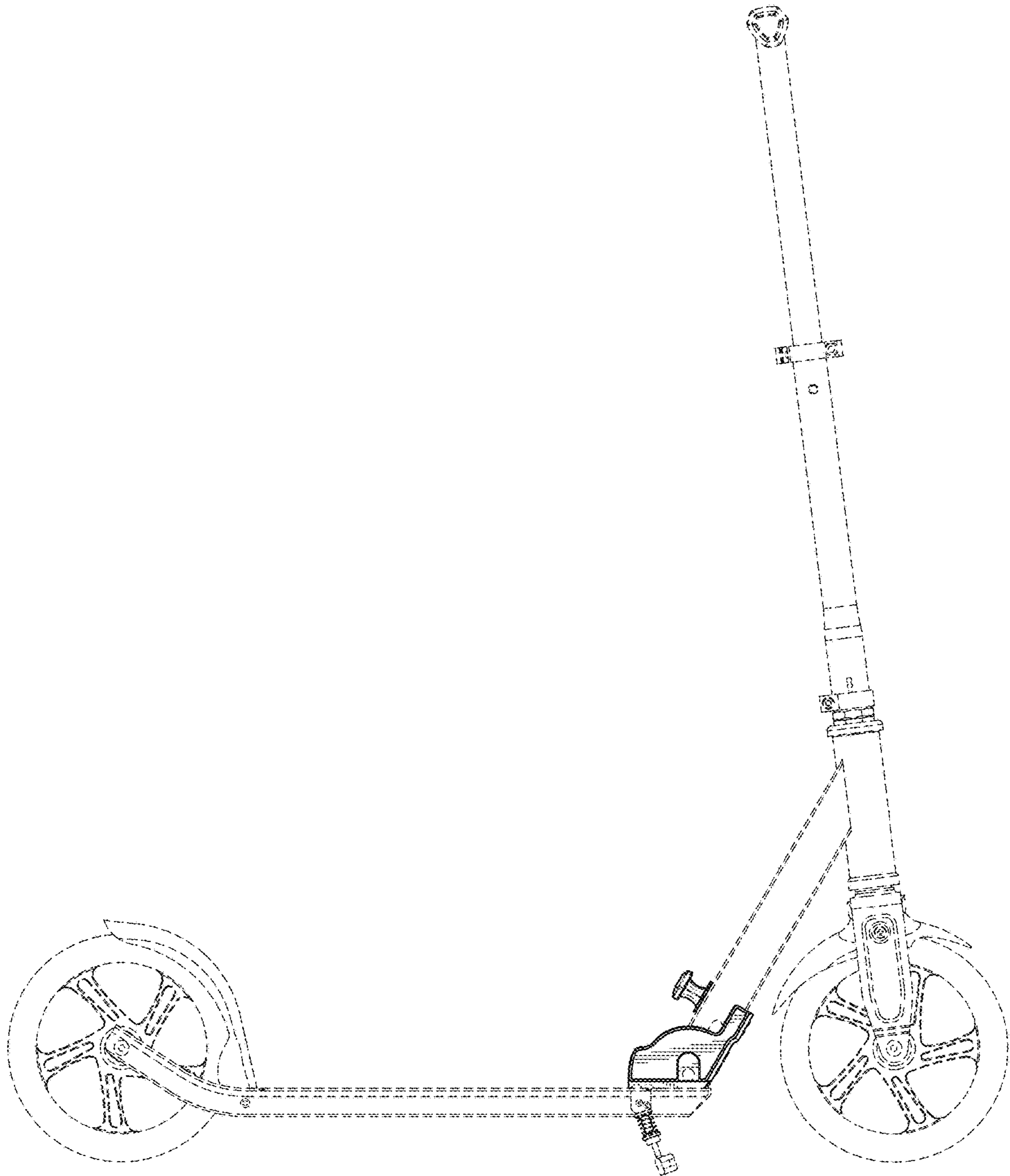

FIG. 5

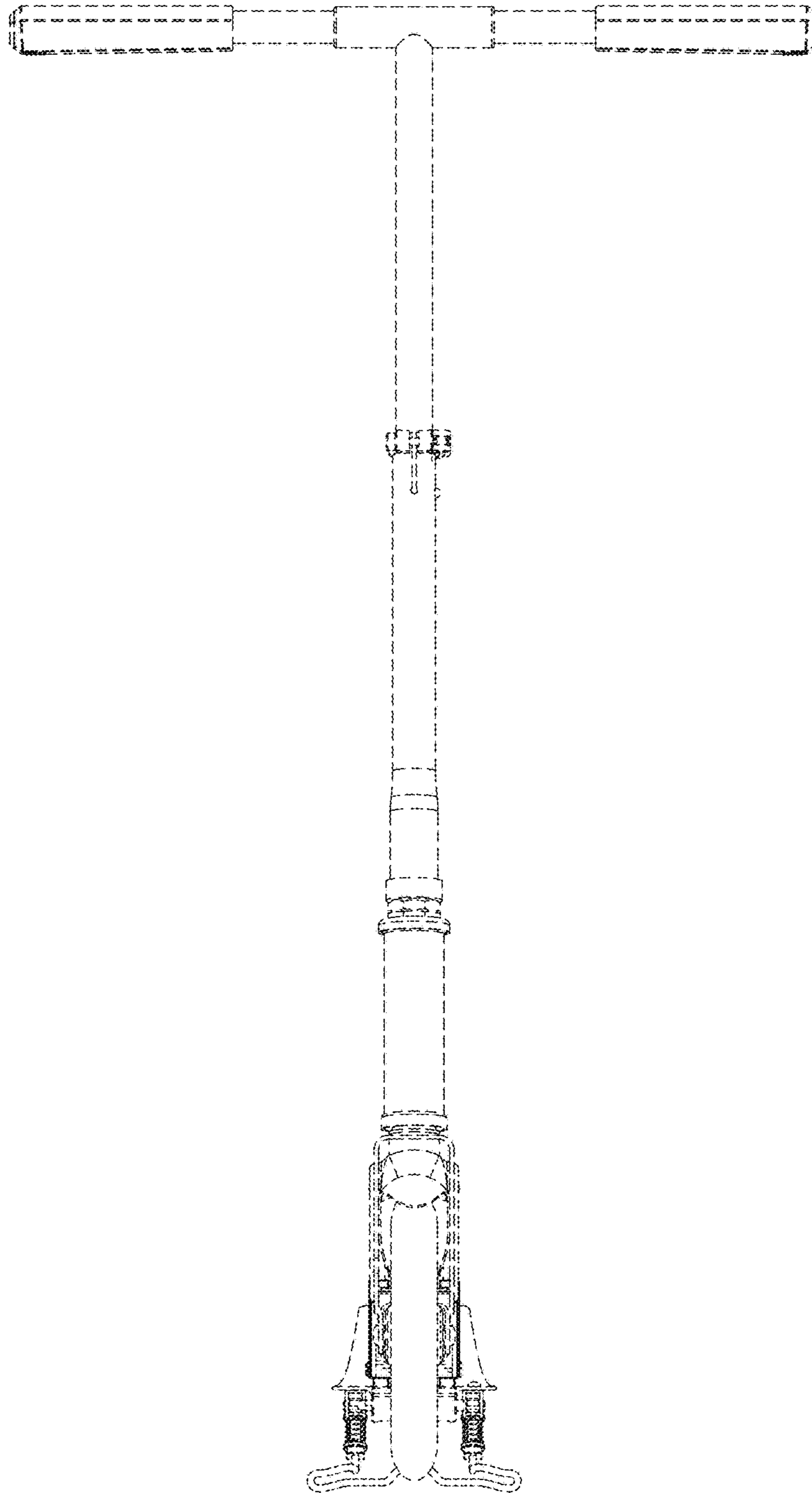

FIG. 6

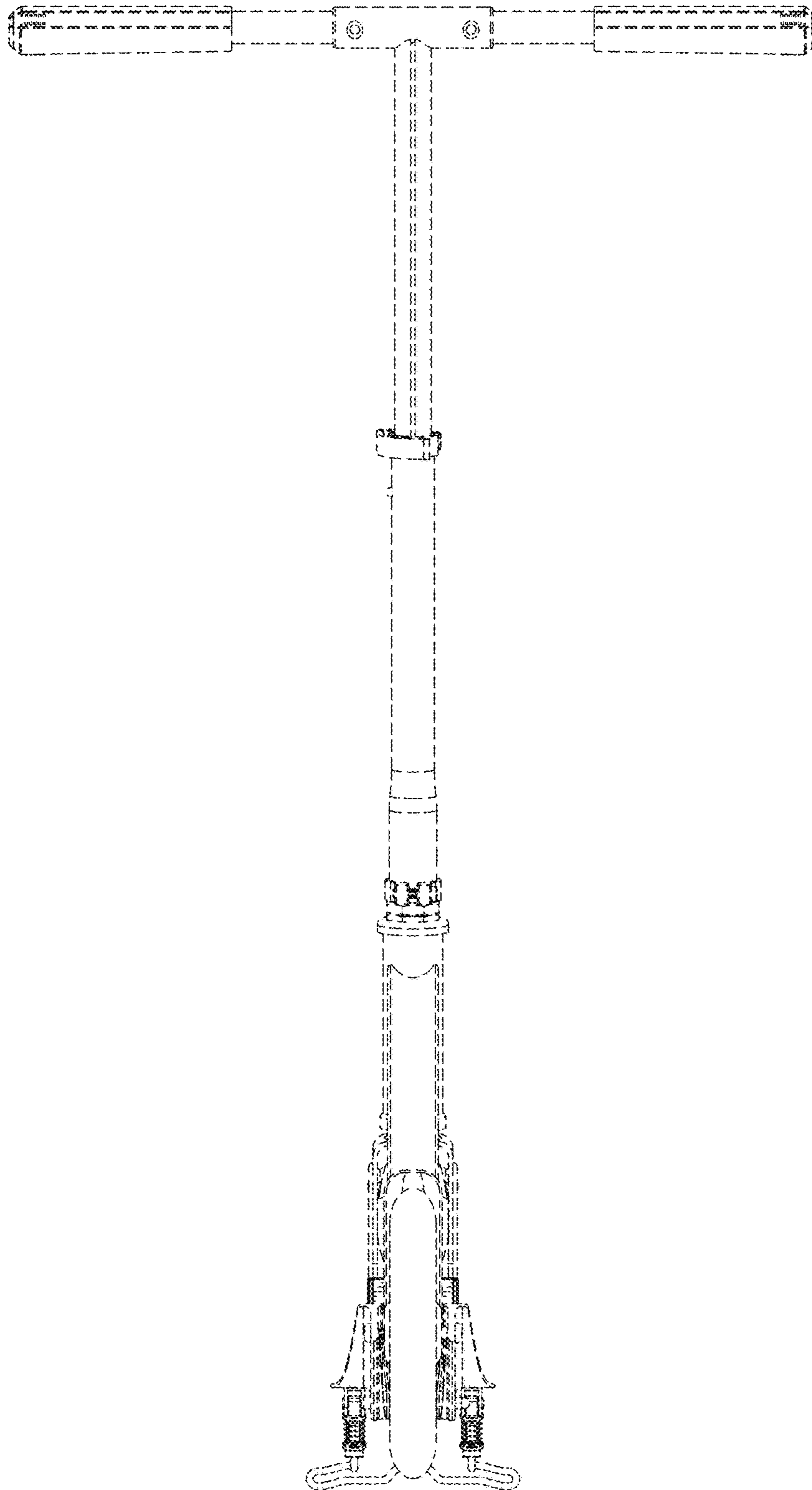

FIG. 7

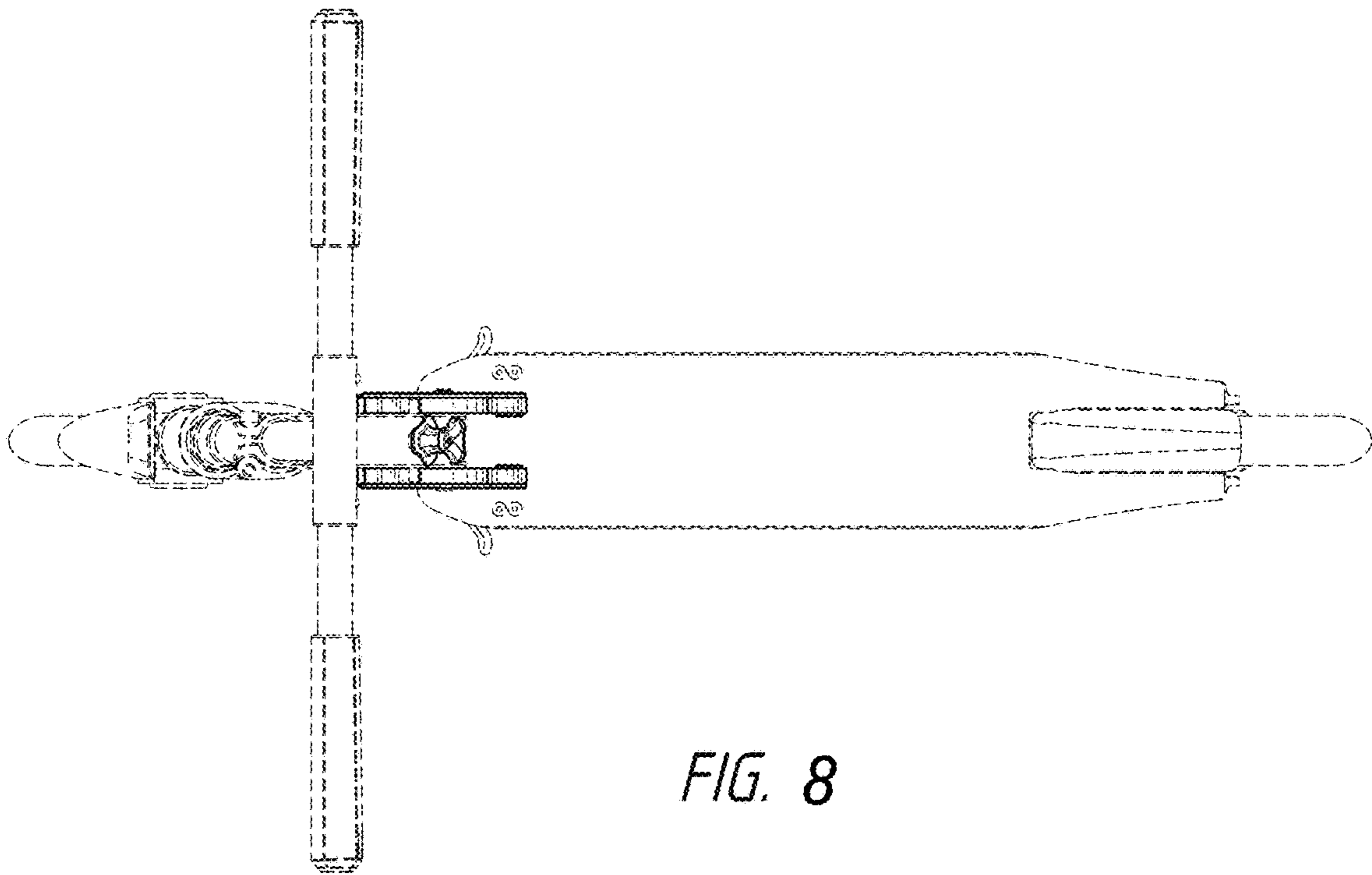

FIG. 8

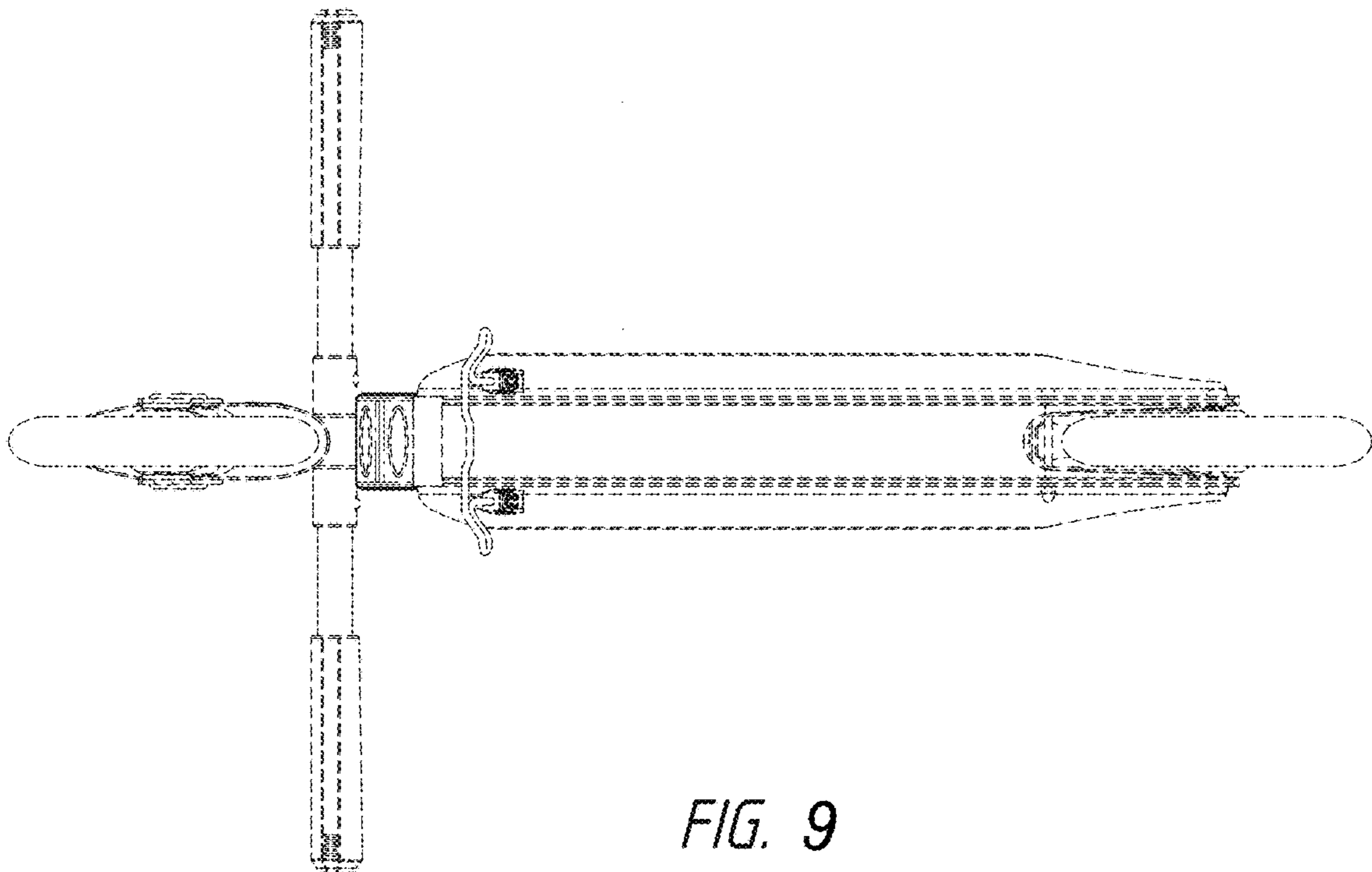

FIG. 9