



US00D866209S

(12) **United States Design Patent** (10) **Patent No.:** **US D866,209 S**  
**Princip et al.** (45) **Date of Patent:** **\*\* Nov. 12, 2019**

(54) **ECONOMY CLASS SEATING UNIT**  
(71) Applicant: **B/E Aerospace, Inc.**, Winston-Salem, NC (US)  
(72) Inventors: **Michael Princip**, Winston-Salem, NC (US); **Stephen Puglisi**, Greensboro, NC (US); **Ryan Suhre**, Winston-Salem, NC (US)  
(73) Assignee: **B/E Aerospace, Inc.**, Winston-Salem, NC (US)

8,596,724 B1 \* 12/2013 Ahad ..... B64D 11/06 297/163  
D707,998 S \* 7/2014 Takahashi ..... D6/716.3  
D723,819 S \* 3/2015 Takahashi ..... D6/356  
D724,337 S \* 3/2015 Nicholas ..... D6/356  
D724,338 S \* 3/2015 Nicholas ..... D6/356  
D724,339 S \* 3/2015 Cai ..... D6/356  
9,834,308 B2 \* 12/2017 Henshaw ..... B64D 11/0606  
9,925,895 B2 \* 3/2018 Ellis ..... B64D 11/06  
10,017,255 B2 \* 7/2018 Smallhorn ..... B64D 11/0624  
10,035,433 B2 \* 7/2018 Muraiti ..... B60N 2/01  
10,035,599 B2 \* 7/2018 Ruiz Lara ..... B64D 11/06  
2006/0232117 A1 \* 10/2006 Johnson ..... A47C 5/043 297/452.18  
2017/0015420 A1 \* 1/2017 Henshaw ..... B64D 11/0606

(\*\*) Term: **15 Years**

\* cited by examiner

(21) Appl. No.: **29/642,256**

*Primary Examiner* — Kevin K Rudzinski

(22) Filed: **Mar. 28, 2018**

*Assistant Examiner* — Paul D Bohannon

(51) **LOC (12) Cl.** ..... **06-06**

(74) *Attorney, Agent, or Firm* — Clements Bernard Walker PLLC

(52) **U.S. Cl.**  
USPC ..... **D6/356**

(57) **CLAIM**

(58) **Field of Classification Search**  
USPC ..... D6/328, 334, 354, 355, 356, 364, 366, D6/601, 655, 702, 708, 708.16, 708.17, D6/708.18, 708.23, 708.24, 708.25, 712, D6/716.1, 716.2, 716.3, 716.4, 716.5, D6/716.6, 716.7; D21/662, 694, 695  
CPC .. A47C 1/03; A47C 4/02; A47C 31/00; B64D 11/06; B62J 1/18; B60N 2/01; H01R 13/60

The ornamental design for an economy class seating unit, as shown and described.

**DESCRIPTION**

See application file for complete search history.

FIG. 1 is a front perspective view showing our new design; FIG. 2 is a back perspective view thereof; FIG. 3 is a back view thereof; FIG. 4 is a left side view thereof; FIG. 5 is a right side view thereof; FIG. 6 is a top view thereof; and, FIG. 7 is a bottom view thereof.

The broken lines shown in FIG. 7 are for the purpose of illustrating portions of the article and form no part of the claimed design.

(56) **References Cited**

U.S. PATENT DOCUMENTS

D486,330 S \* 2/2004 Laming ..... D6/716.3  
D686,422 S \* 7/2013 Robinson ..... D6/356

**1 Claim, 5 Drawing Sheets**

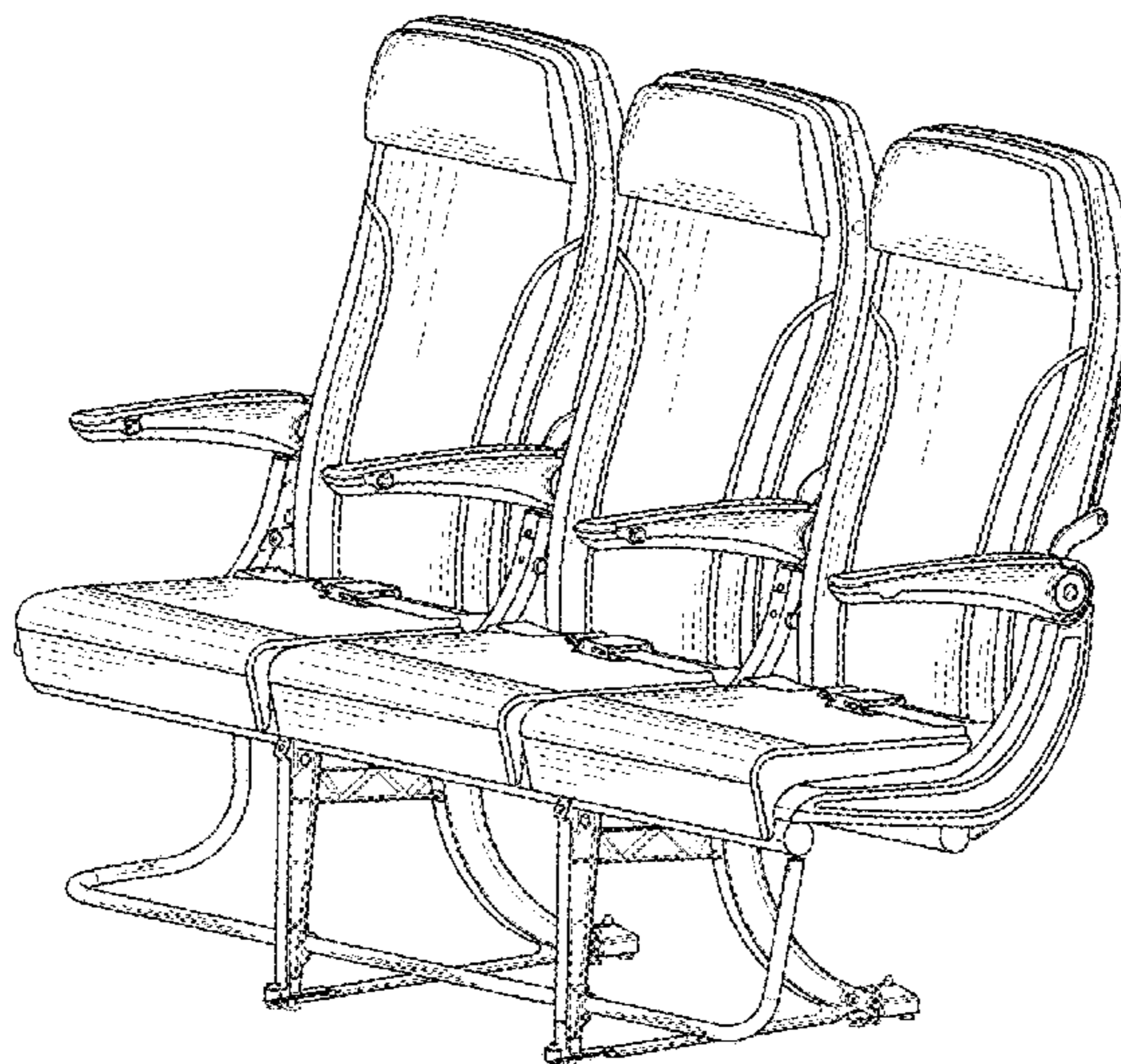



FIG. 1

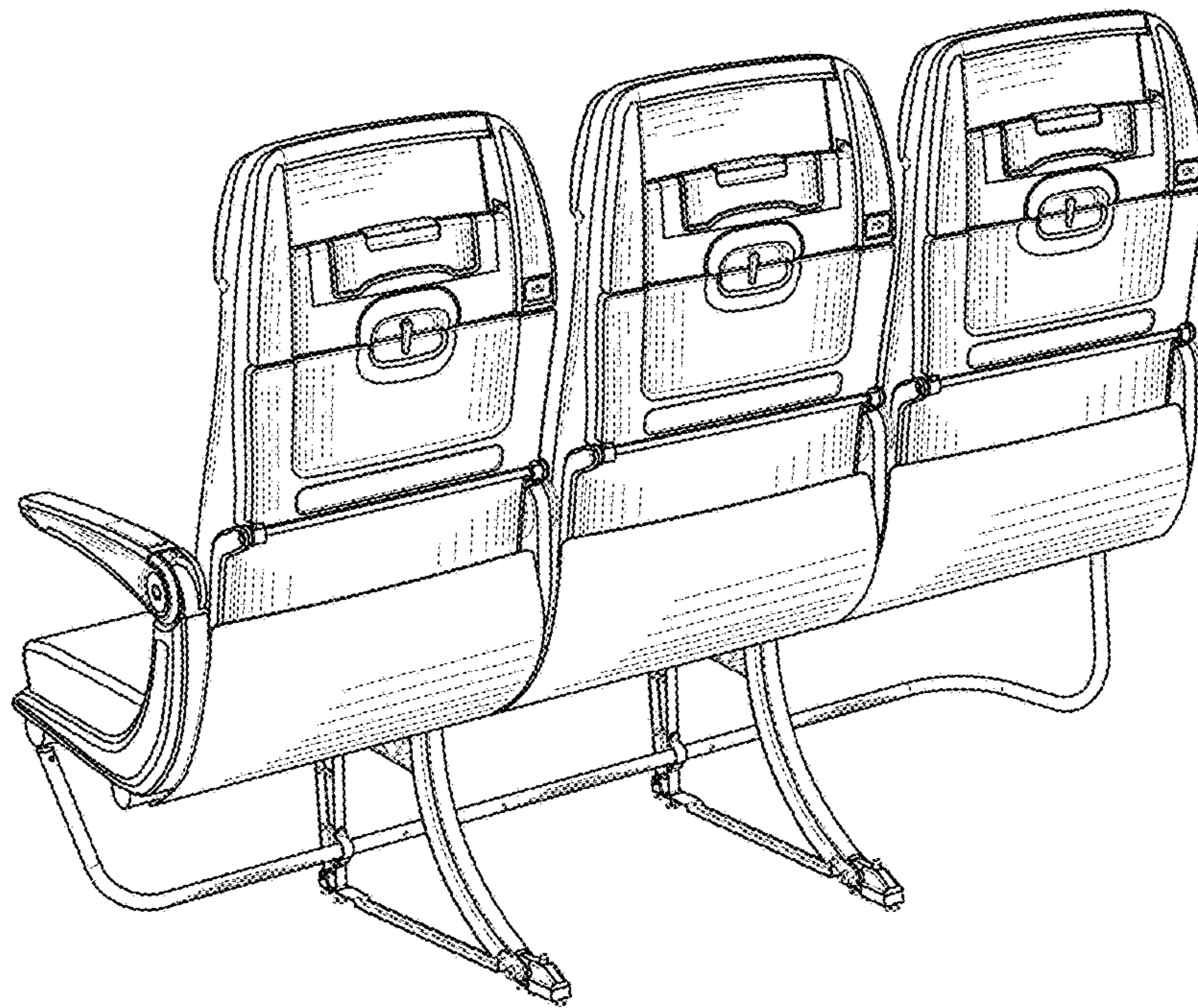

FIG. 2

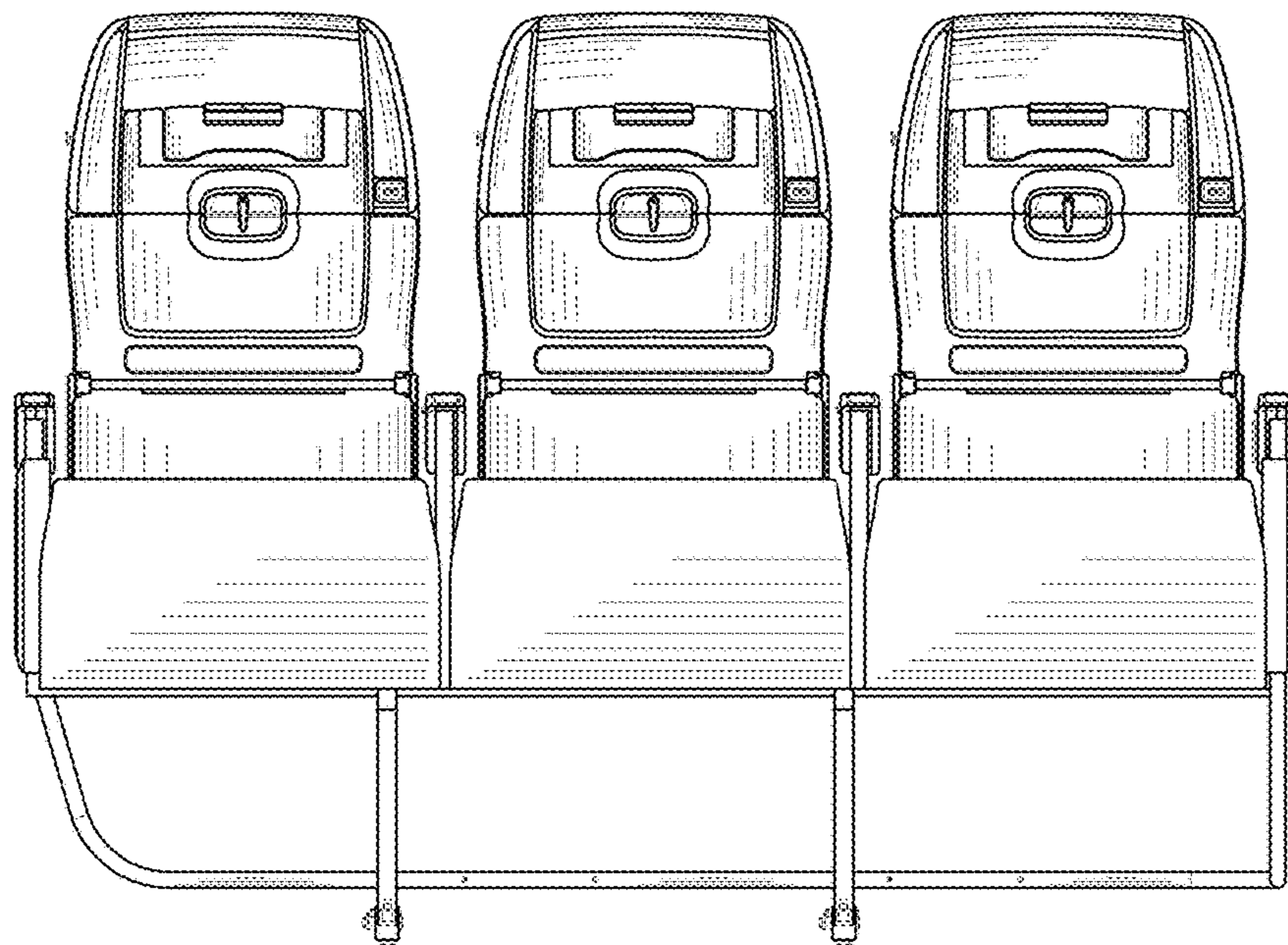

FIG. 3

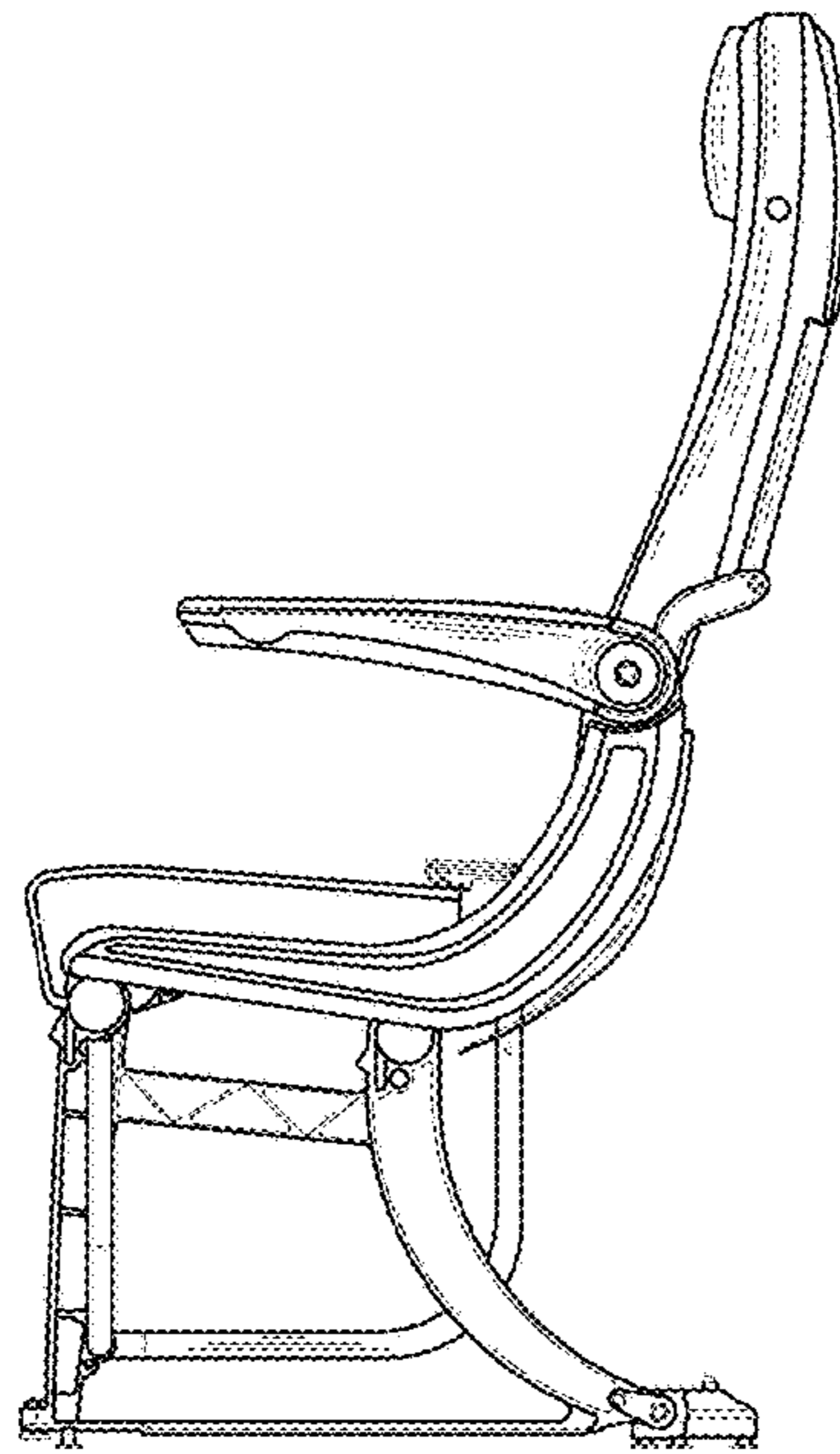

FIG. 4

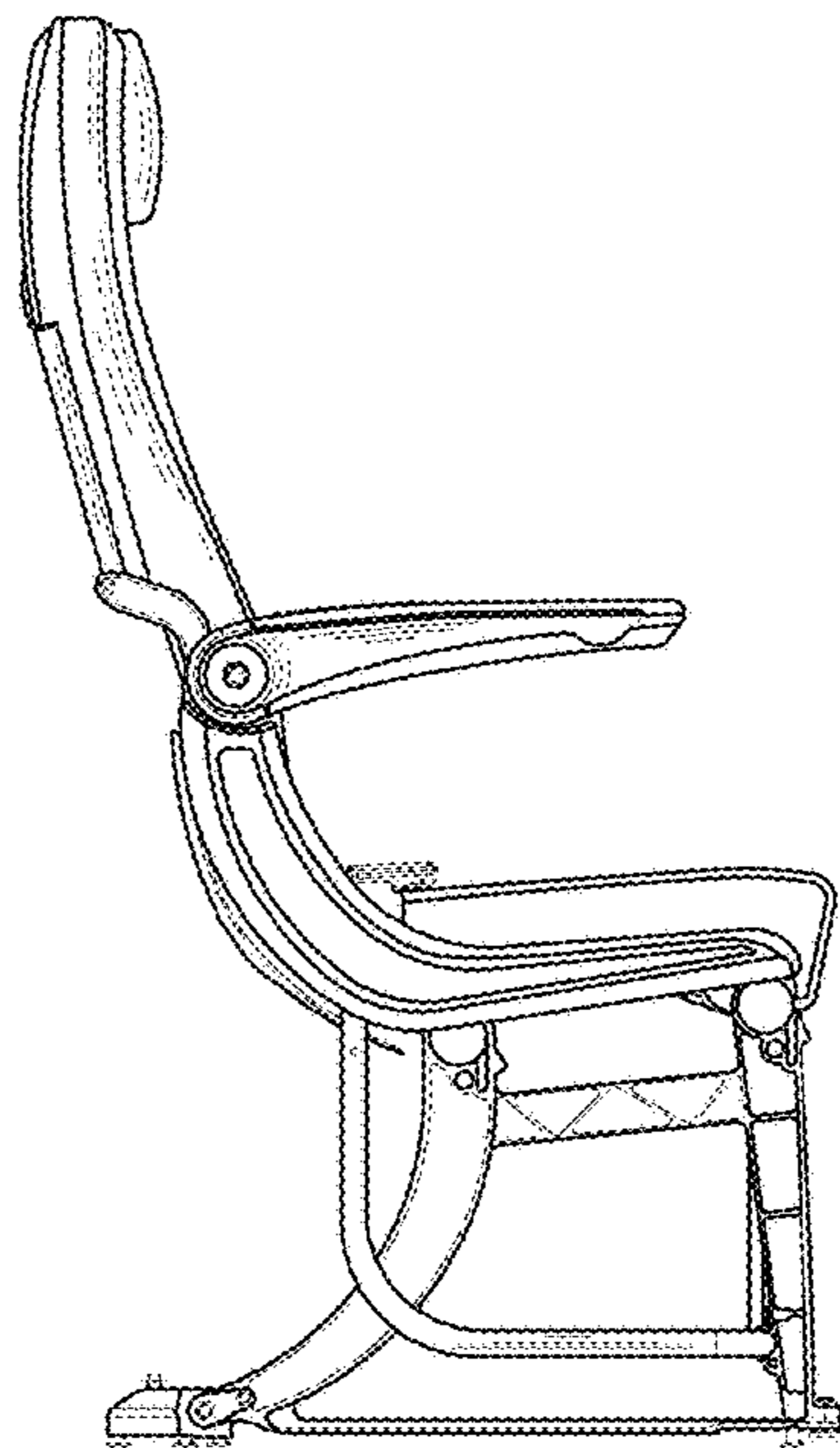

FIG. 5

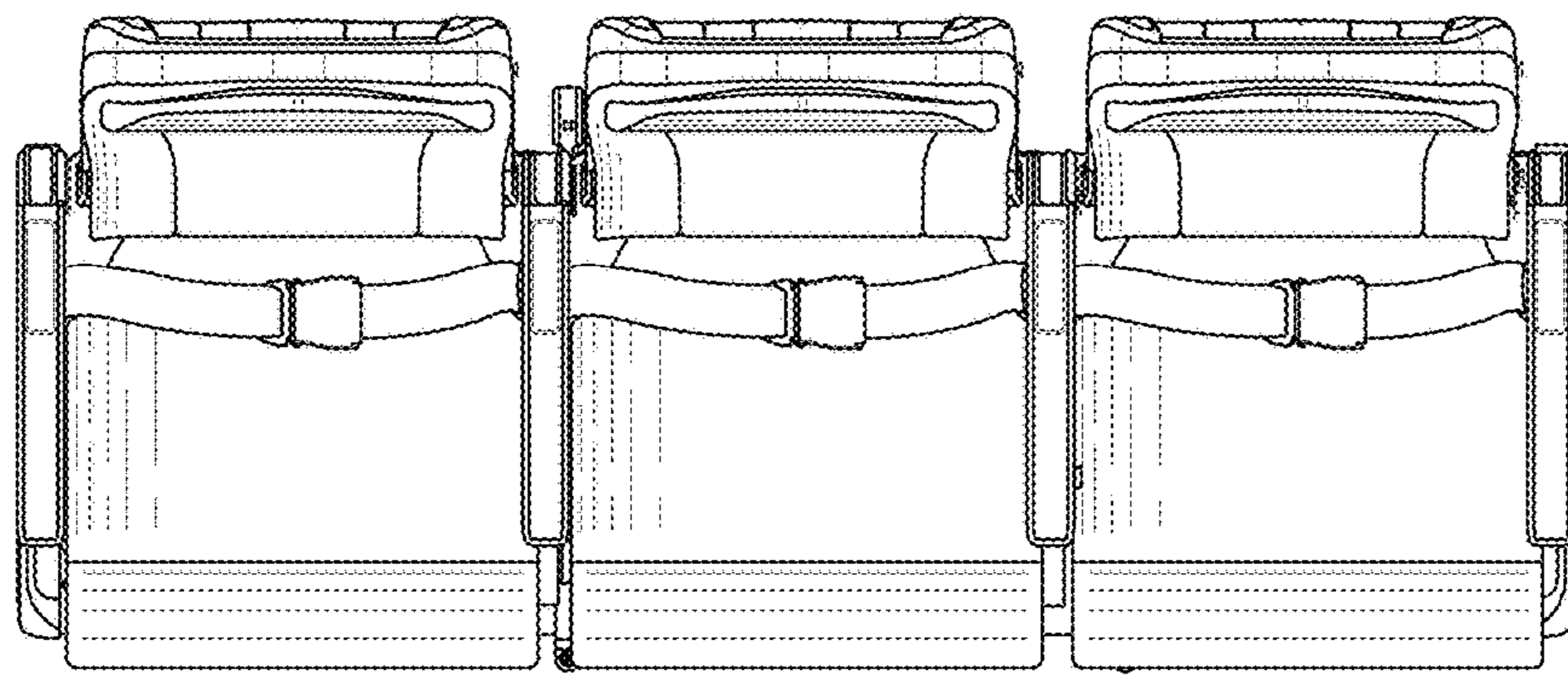

FIG. 6

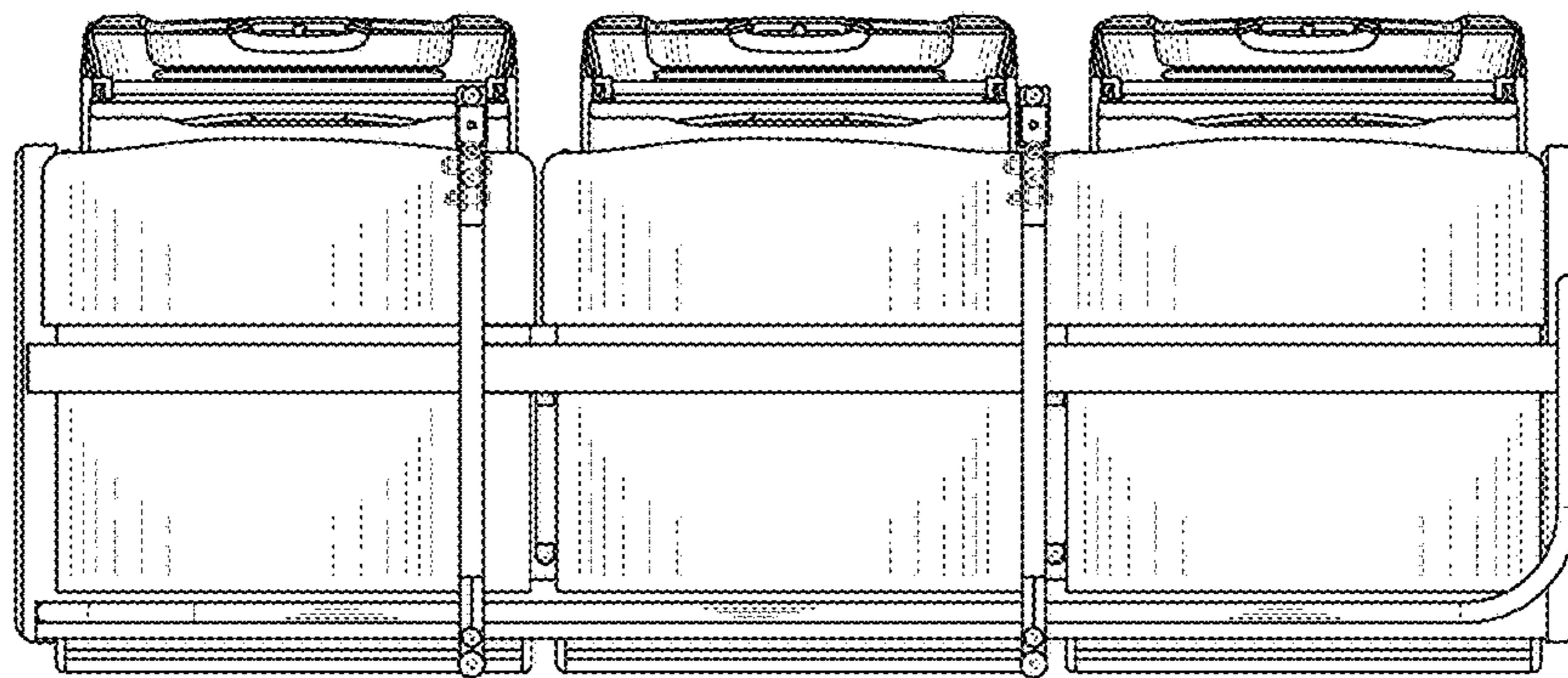

FIG. 7