



US00D865849S

(12) **United States Design Patent**  
**Yoshida**

(10) **Patent No.:** **US D865,849 S**

(45) **Date of Patent:** **\*\* Nov. 5, 2019**

(54) **PROJECTOR**

D710,925 S \* 8/2014 Tabuchi ..... D16/230  
D757,148 S \* 5/2016 Amikura ..... D16/230  
D774,586 S \* 12/2016 Yamamoto ..... D16/225

(71) Applicant: **FUJIFILM Corporation**, Tokyo (JP)

(72) Inventor: **Koji Yoshida**, Saitama (JP)

(73) Assignee: **FUJIFILM Corporation**, Tokyo (JP)

(\*\*) Term: **15 Years**

(21) Appl. No.: **29/658,076**

(22) Filed: **Jul. 27, 2018**

(30) **Foreign Application Priority Data**

Jan. 30, 2018 (JP) ..... 2018-001722

(51) **LOC (12) Cl.** ..... **16-02**

(52) **U.S. Cl.**  
USPC ..... **D16/225**; D16/230

(58) **Field of Classification Search**  
USPC ..... D16/221, 225, 229-231, 234; D21/514;  
353/101, 119, 122

CPC .... G03B 21/14; G03B 21/144; G03B 21/145;  
G03B 21/12; G03B 21/16; G03B 21/00;  
G03B 21/001; G03B 21/003

See application file for complete search history.

(56) **References Cited**

**U.S. PATENT DOCUMENTS**

D466,143 S \* 11/2002 Torikai ..... D16/230  
7,029,132 B2 \* 4/2006 Tsubata ..... H04N 9/3141  
353/122  
D527,407 S \* 8/2006 Kawasaki ..... D16/225  
D636,426 S \* 4/2011 Kawaguchi ..... D16/225  
D683,782 S \* 6/2013 Ishibashi ..... D16/230

**FOREIGN PATENT DOCUMENTS**

JP D1369993 S 9/2009

**OTHER PUBLICATIONS**

Lavars, Nick "Fujifilm flips the script with a rotating projector lens,"  
Sep. 26, 2018. Retrieved on Jun. 26, 2019. Retrieved from the  
Internet: <https://newatlas.com/fujifilm-rotating-lens/56514/>.  
Office Action issued in Japanese Patent Application No. 2018-  
001722, dated Jul. 5, 2018.

\* cited by examiner

*Primary Examiner* — Wan Laymon

(74) *Attorney, Agent, or Firm* — Birch, Stewart, Kolasch  
& Birch, LLP

(57) **CLAIM**

The ornamental design for a projector, as shown and  
described.

**DESCRIPTION**

FIG. 1 is a right perspective view of a projector showing my  
new design;  
FIG. 2 is a front view thereof;  
FIG. 3 is a rear view thereof;  
FIG. 4 is a top plan view thereof;  
FIG. 5 is a bottom plan view thereof;  
FIG. 6 is a right side view thereof; and,  
FIG. 7 is a left side view thereof.  
Lens body can be mounted on concave portion of right-  
bottom surface.

**1 Claim, 6 Drawing Sheets**

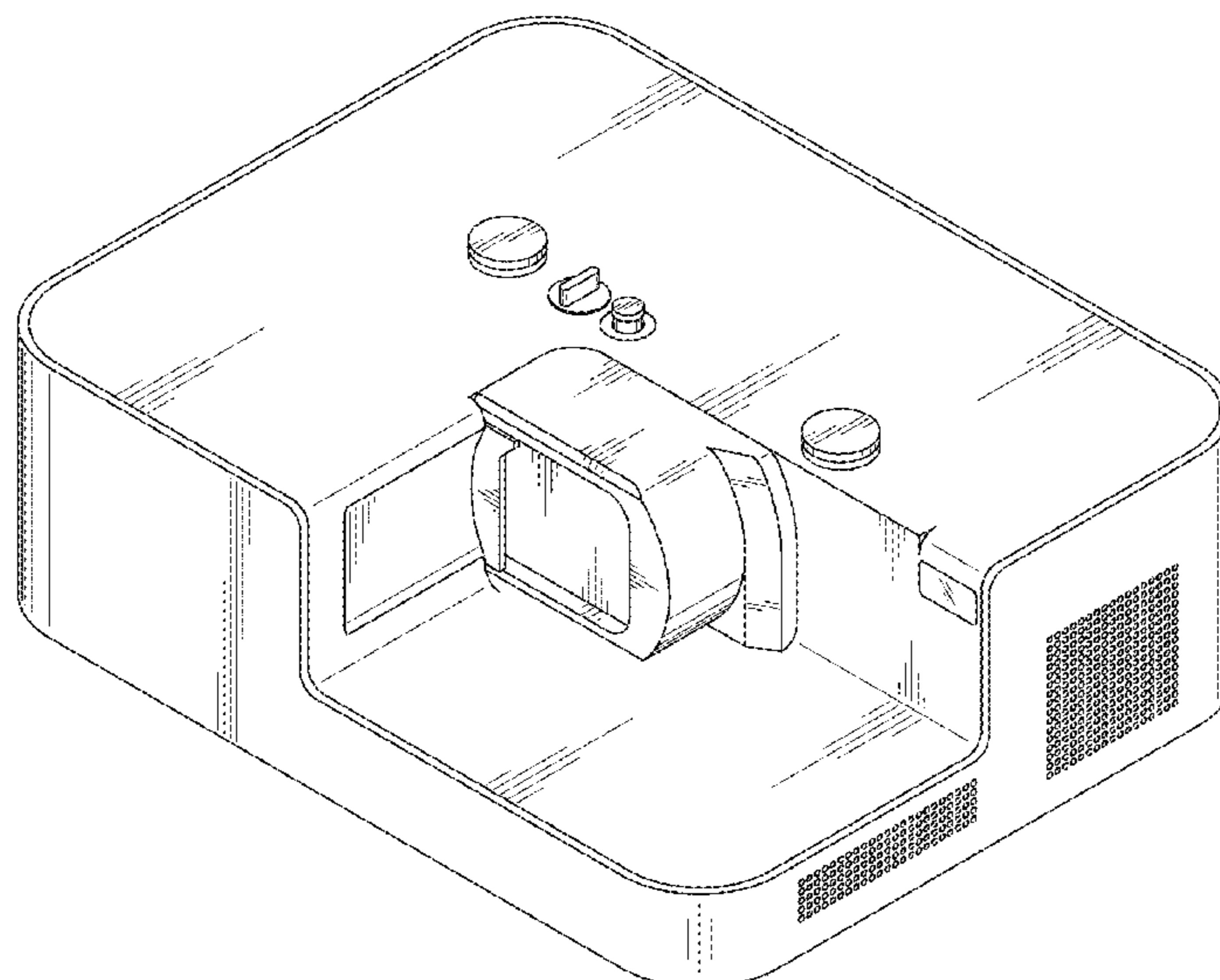

FIG. 1

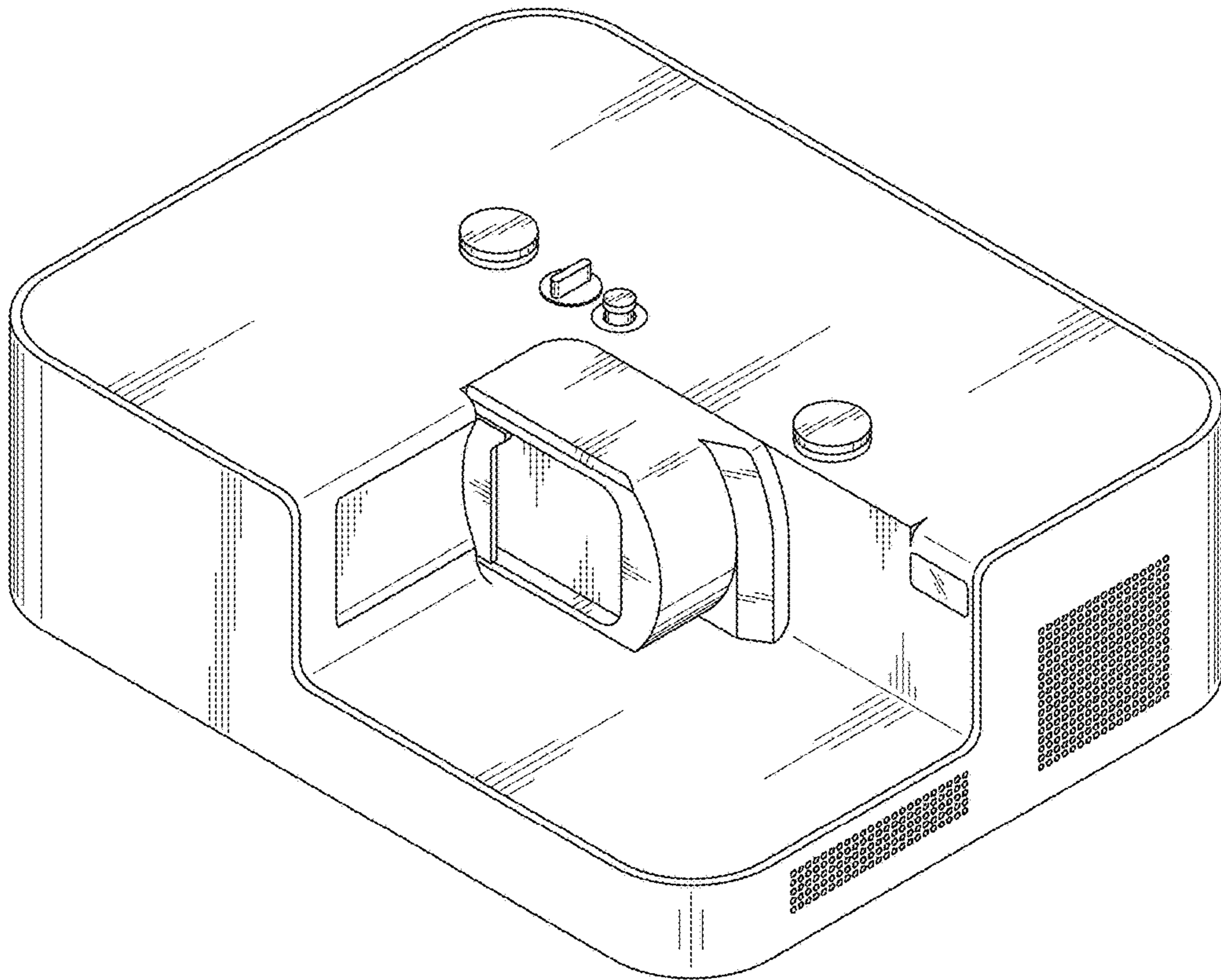
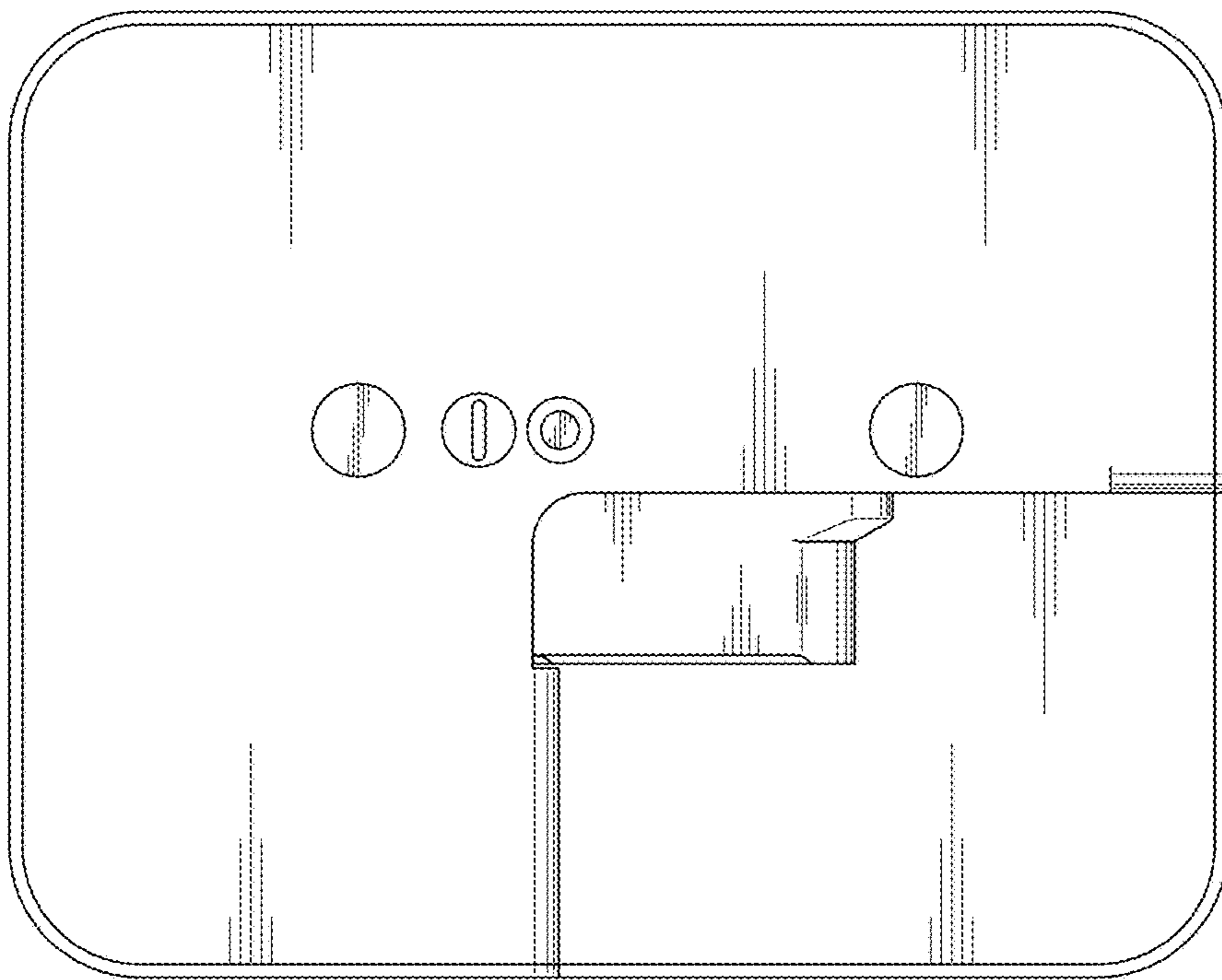
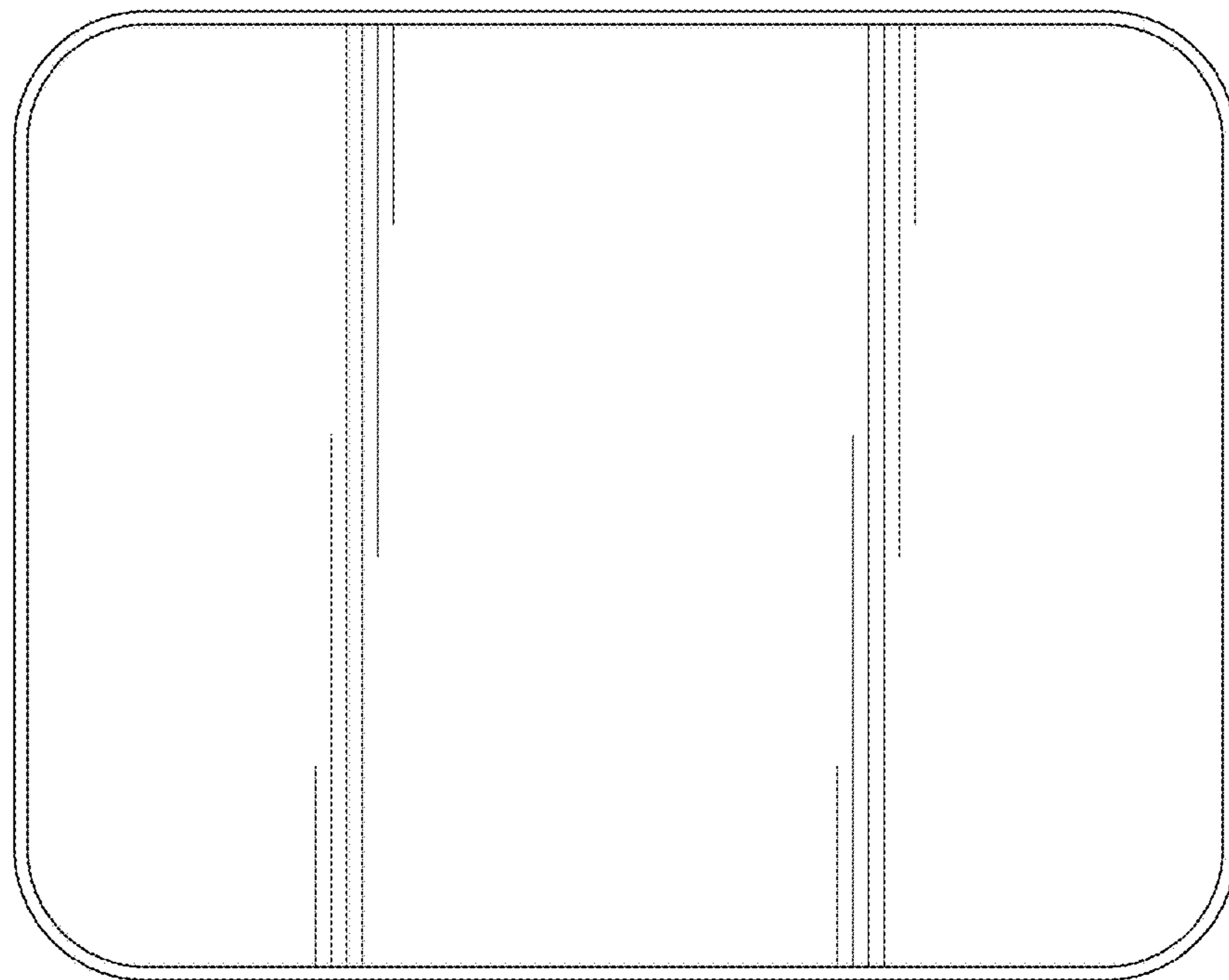

FIG. 2



**FIG. 3**



**FIG. 4**

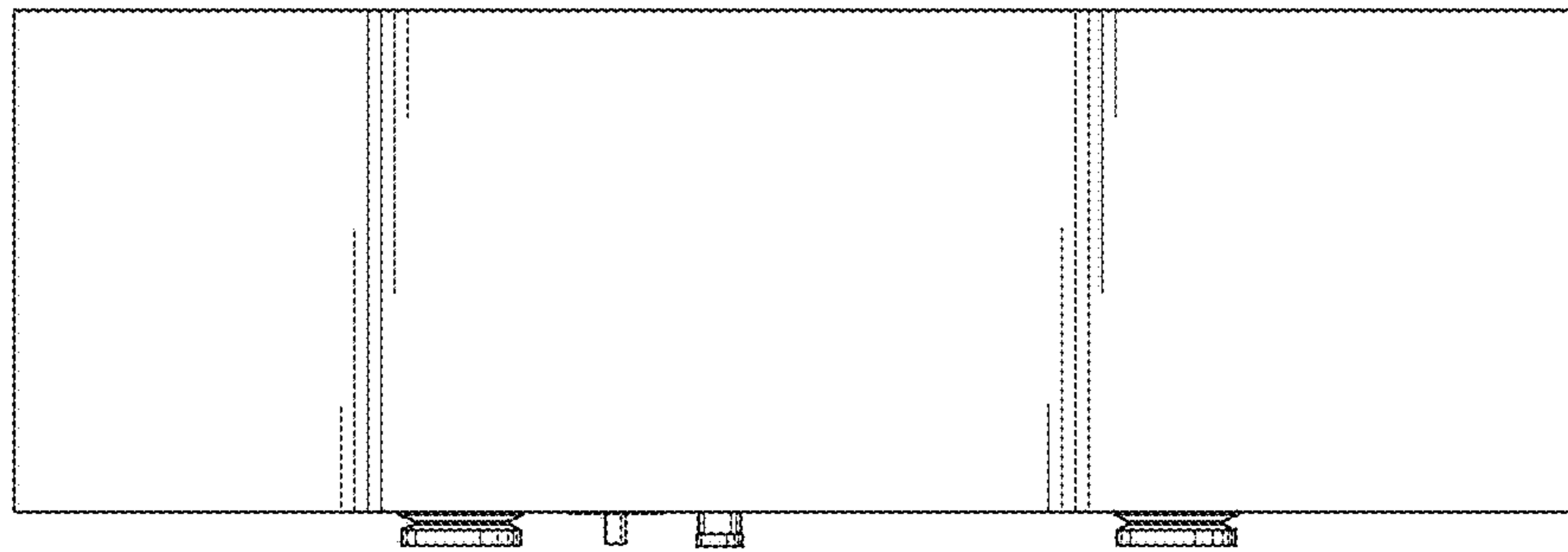

**FIG. 5**

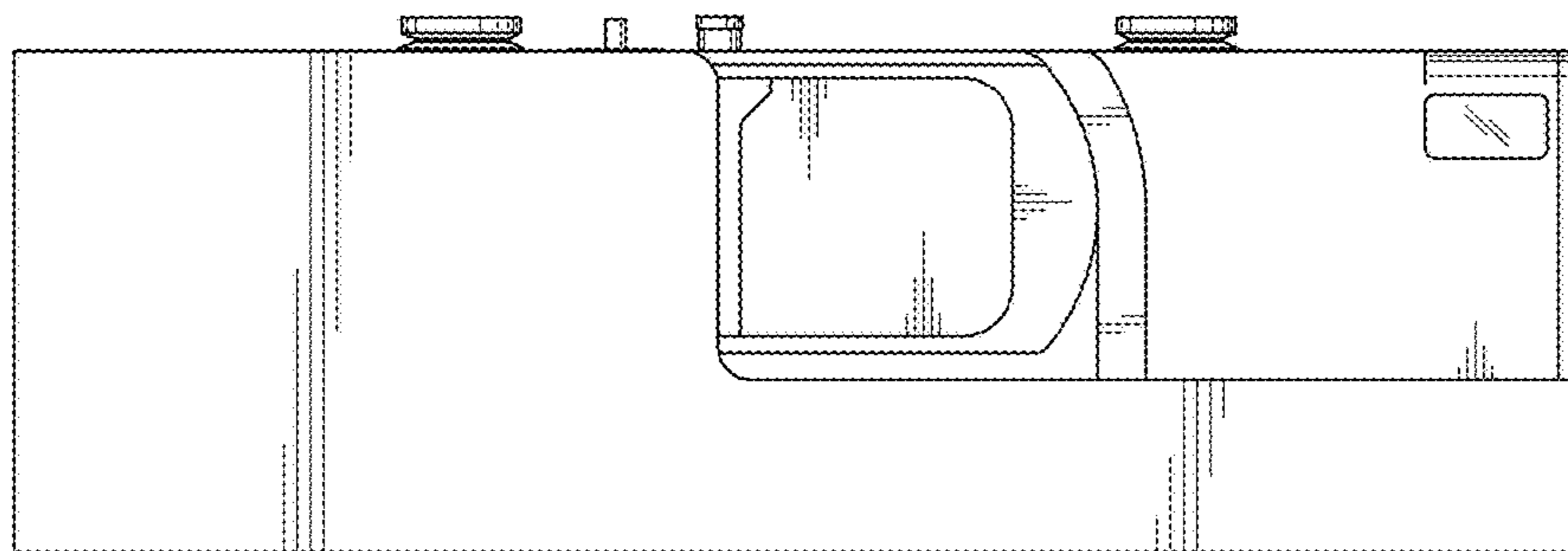
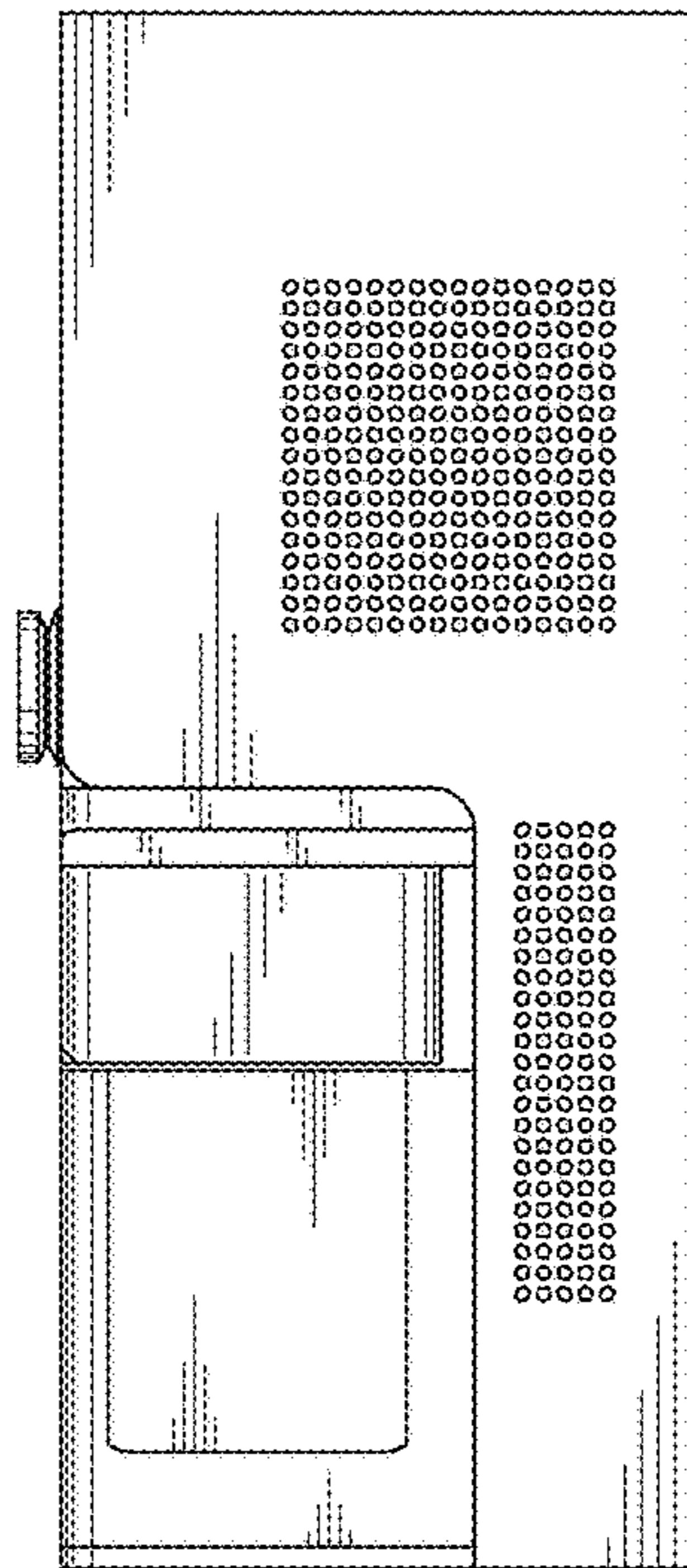

FIG. 6





**FIG. 7**

