



US00D865604S

(12) **United States Design Patent** (10) **Patent No.:** **US D865,604 S**  
**Kang** (45) **Date of Patent:** **\*\* Nov. 5, 2019**

(54) **DASHBOARD FOR VEHICLE**  
(71) Applicant: **LG ELECTRONICS INC.**, Seoul (KR)  
(72) Inventor: **Seungmo Kang**, Seoul (KR)  
(73) Assignee: **LG ELECTRONICS INC.**, Seoul (KR)

D92,066 S \* 4/1934 Ellis ..... D12/192  
D182,598 S \* 4/1958 Kiddon ..... D12/192  
5,305,011 A \* 4/1994 Furuya ..... B60K 35/00  
345/7  
D833,933 S \* 11/2018 Gibson ..... D12/192  
D835,606 S \* 12/2018 Won ..... B60K 35/00  
D14/215  
D836,049 S \* 12/2018 Ryu ..... B60K 35/00  
D12/192  
2008/0211652 A1 \* 9/2008 Cope ..... B60K 35/00  
340/461

(\*\*) Term: **15 Years**  
(21) Appl. No.: **35/505,560**

\* cited by examiner  
*Primary Examiner* — Mary Ann Calabrese  
(74) *Attorney, Agent, or Firm* — Birch, Stewart, Kolasch & Birch, LLP

(22) Filed: **Feb. 28, 2018**

(80) **Hague Agreement Data**  
Int. Filing Date: **Feb. 28, 2018**  
Int. Reg. No.: **DM/100166**  
Int. Reg. Date: **Feb. 28, 2018**  
Int. Reg. Pub. Date: **Aug. 31, 2018**

(57) **CLAIM**  
The ornamental design for a dashboard for vehicle, as shown and described.

(30) **Foreign Application Priority Data**  
Sep. 1, 2017 (KR) ..... 30-2017-0041044  
(51) **LOC (12) Cl.** ..... **12-16**  
(52) **U.S. Cl.**  
USPC ..... **D12/192**  
(58) **Field of Classification Search**  
USPC ..... D12/190, 192, 195, 400; D14/214  
CPC ..... B60K 37/00; B60K 37/02; B60K 37/04;  
B60K 37/06; B60K 2370/65; B60K  
2370/654; B60K 2370/658; B60R 11/00;  
A60R 2011/0005; A60R 2011/0007;  
A60R 2011/0008  
See application file for complete search history.

**DESCRIPTION**  
1. Dashboard for vehicle  
1.1 is a front perspective view of a dashboard for vehicles showing our new design:  
1.2 is front view thereof:  
1.3 is a rear view thereof:  
1.4 is a right side view thereof:  
1.5 is a left side view thereof:  
1.6 is a top elevation view thereof:  
1.7 is a bottom view thereof: and,  
1.8 is a front perspective view thereof, shown in an environment of use.  
The broken lines depict portions of the dashboard for vehicle that form no part of the claimed design; the dash-dot broken lines define the boundary of the claimed design and form no part thereof.  
The claimed design is characterized by a seamless dashboard for vehicle which consists of a glass.

(56) **References Cited**  
U.S. PATENT DOCUMENTS  
D51,702 S \* 1/1918 Joseph ..... D12/192  
D55,172 S \* 5/1920 Hoffman et al. .... D12/192

**1 Claim, 8 Drawing Sheets**

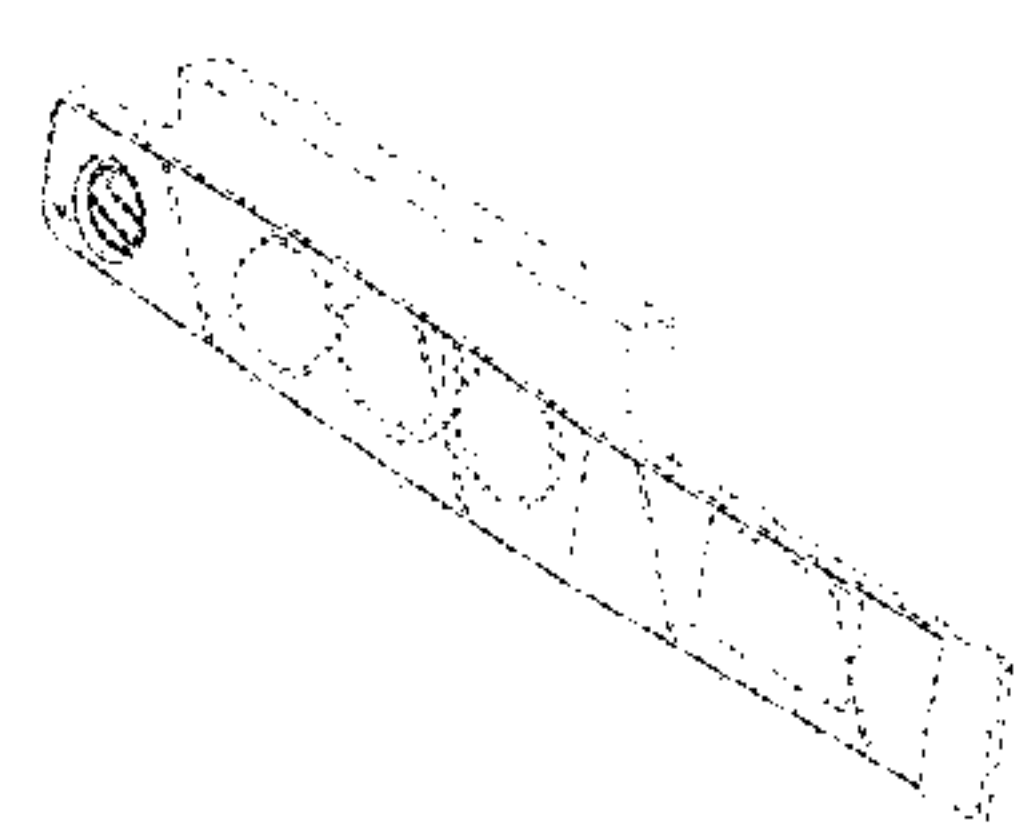

1.1

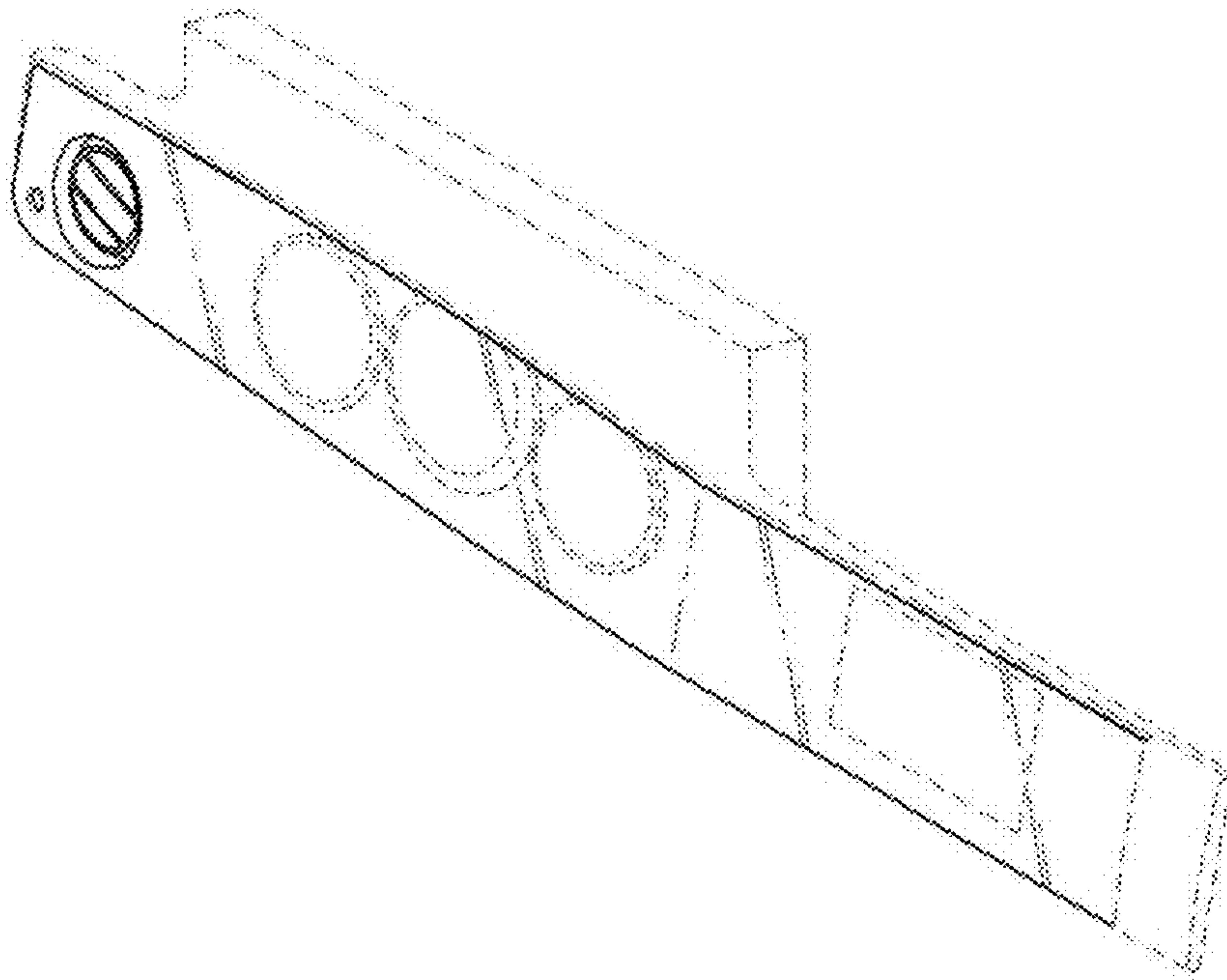

1.2

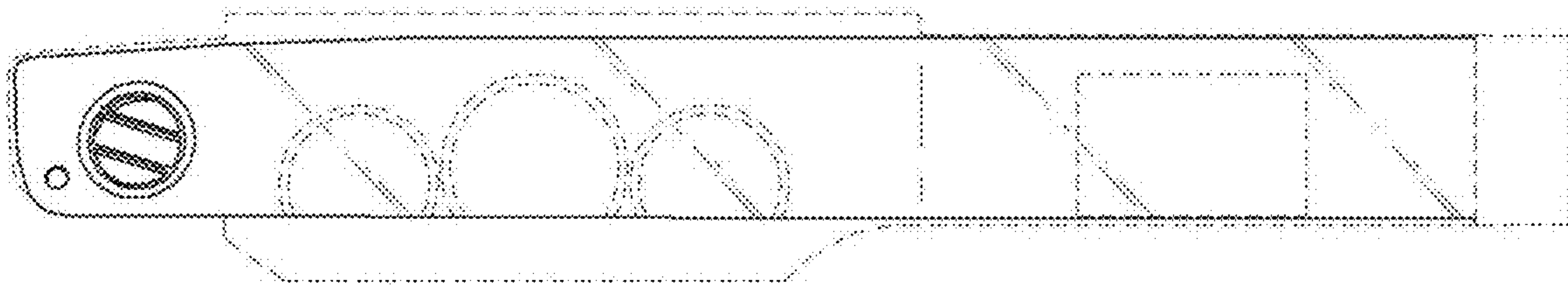

1.3

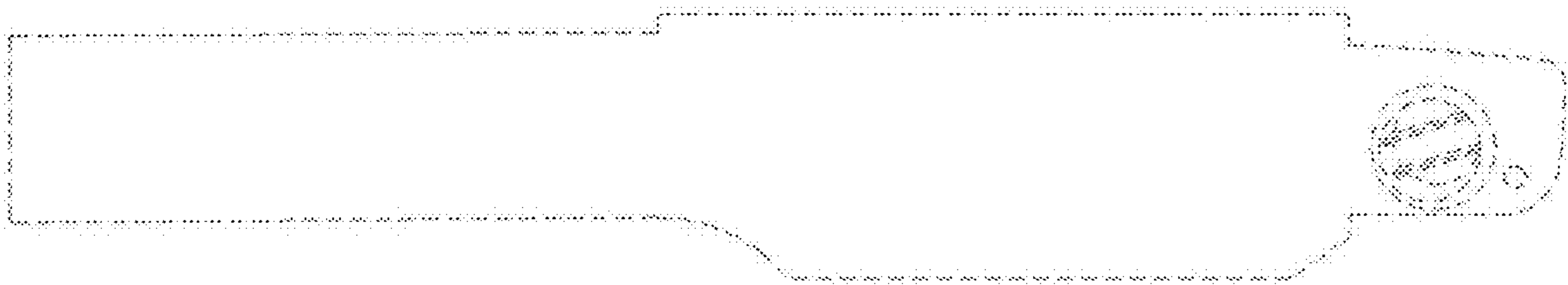

1.4

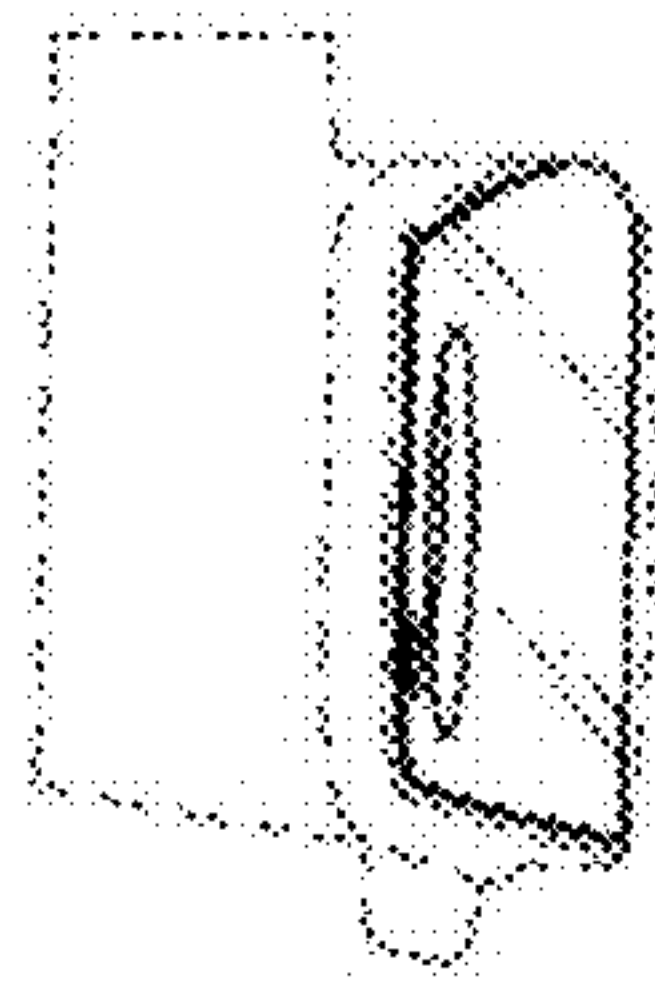

1.5

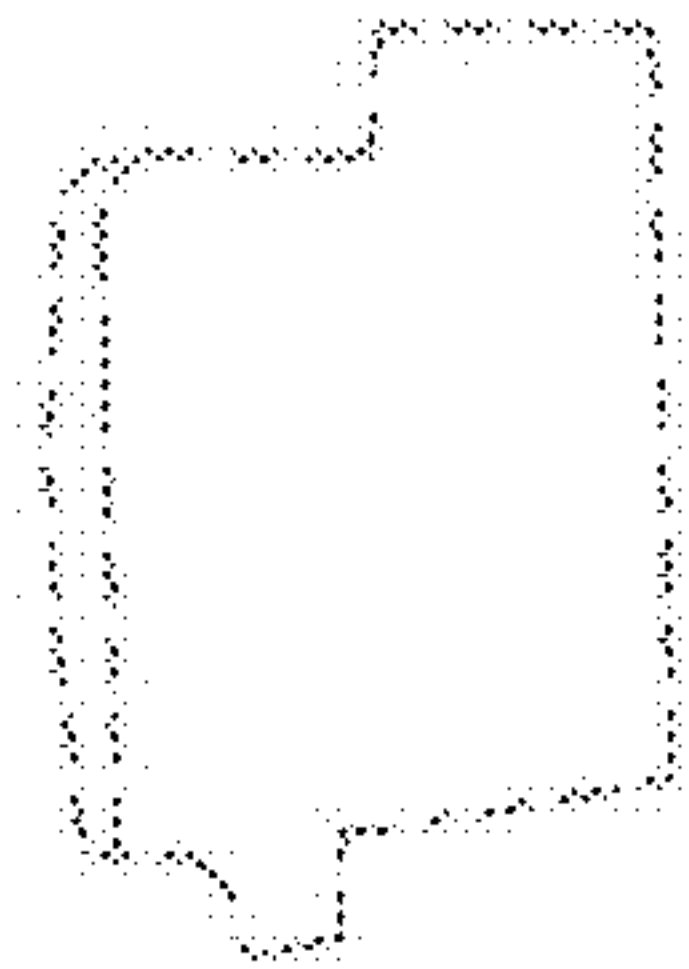

1.6

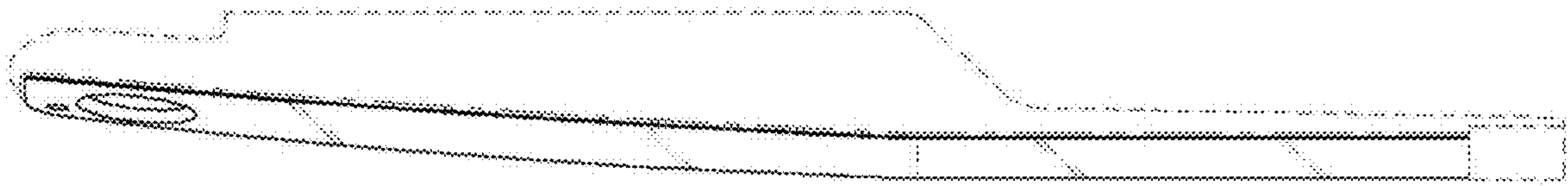

1.7

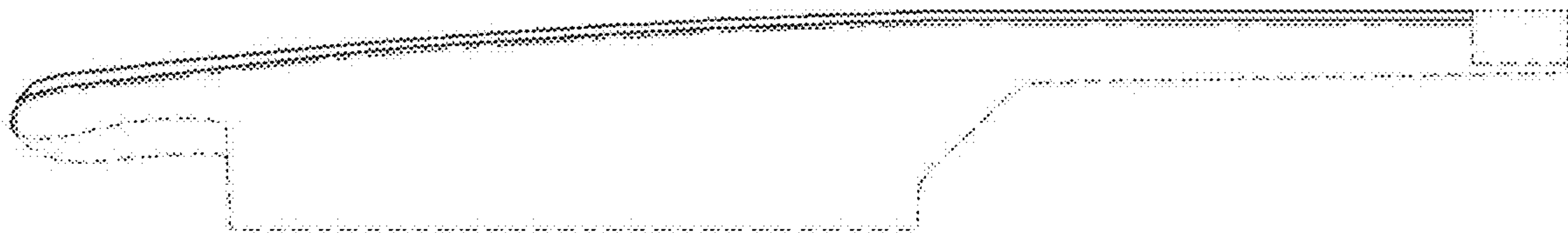



1.8

