



US00D865590S

(12) **United States Design Patent** (10) **Patent No.:** **US D865,590 S**
Bridan (45) **Date of Patent:** **** Nov. 5, 2019**

(54) **VEHICLE HOOD**

(71) Applicant: **HONDA MOTOR CO., LTD.**,
Minato-ku, Tokyo (JP)

(72) Inventor: **Iliya Bridan**, Long Beach, CA (US)

(73) Assignee: **HONDA MOTOR CO., LTD.**, Tokyo
(JP)

(**) Term: **15 Years**

(21) Appl. No.: **29/632,660**

(22) Filed: **Jan. 9, 2018**

(51) **LOC (12) Cl.** **12-16**

(52) **U.S. Cl.**
USPC **D12/173**

(58) **Field of Classification Search**
USPC D12/173, 196, 86, 90-92, 181;
180/69.21, 69.2, 69.22; 296/190.1-190.5,
296/190.8, 193.11, 37.6
CPC B62D 25/10; B62D 25/06; B62D 65/02;
B62D 25/12; B60Q 1/00
See application file for complete search history.

(56) **References Cited**

U.S. PATENT DOCUMENTS

D685,303 S *	7/2013	Tani et al.	D12/173
D787,389 S *	5/2017	Wolff et al.	D12/173
D818,904 S *	5/2018	Jeong	D12/173
D818,907 S *	5/2018	Whitla et al.	D12/173

* cited by examiner

Primary Examiner — Melody N Brown

(74) *Attorney, Agent, or Firm* — Arent Fox LLP

(57) **CLAIM**

The ornamental design for a vehicle hood, as shown and described.

DESCRIPTION

FIG. 1 is a top, rear and left side perspective view of a vehicle hood showing our new design;
FIG. 2 is a top, rear and left side perspective view thereof;
FIG. 3 is a top, front and right side perspective view thereof;
FIG. 4 is a top, front and left side perspective view thereof;
FIG. 5 is a rear elevational view thereof;
FIG. 6 is a front elevational view thereof;
FIG. 7 is a right side elevational view thereof;
FIG. 8 is a left side elevational view thereof;
FIG. 9 is a top plan view thereof;
FIG. 10 is a bottom plan view thereof;
FIG. 11 is a top, rear and left side perspective view of a vehicle hood showing a second embodiment of our new design;
FIG. 12 is a top, rear and right side perspective view of FIG. 11;
FIG. 13 is a top, front and right side perspective view of FIG. 11;
FIG. 14 is a top, front and left side perspective view of FIG. 11;
FIG. 15 is a rear elevational view of FIG. 11;
FIG. 16 is a front elevational view of FIG. 11;
FIG. 17 is a right side elevational view of FIG. 11;
FIG. 18 is a left side elevational view of FIG. 11;
FIG. 19 is a top plan view of FIG. 11; and,
FIG. 20 is a bottom plan view of FIG. 11.
The broken lines shown in the figures are included for the purpose of illustrating portions of the vehicle hood and form no part of the claimed design.

1 Claim, 20 Drawing Sheets

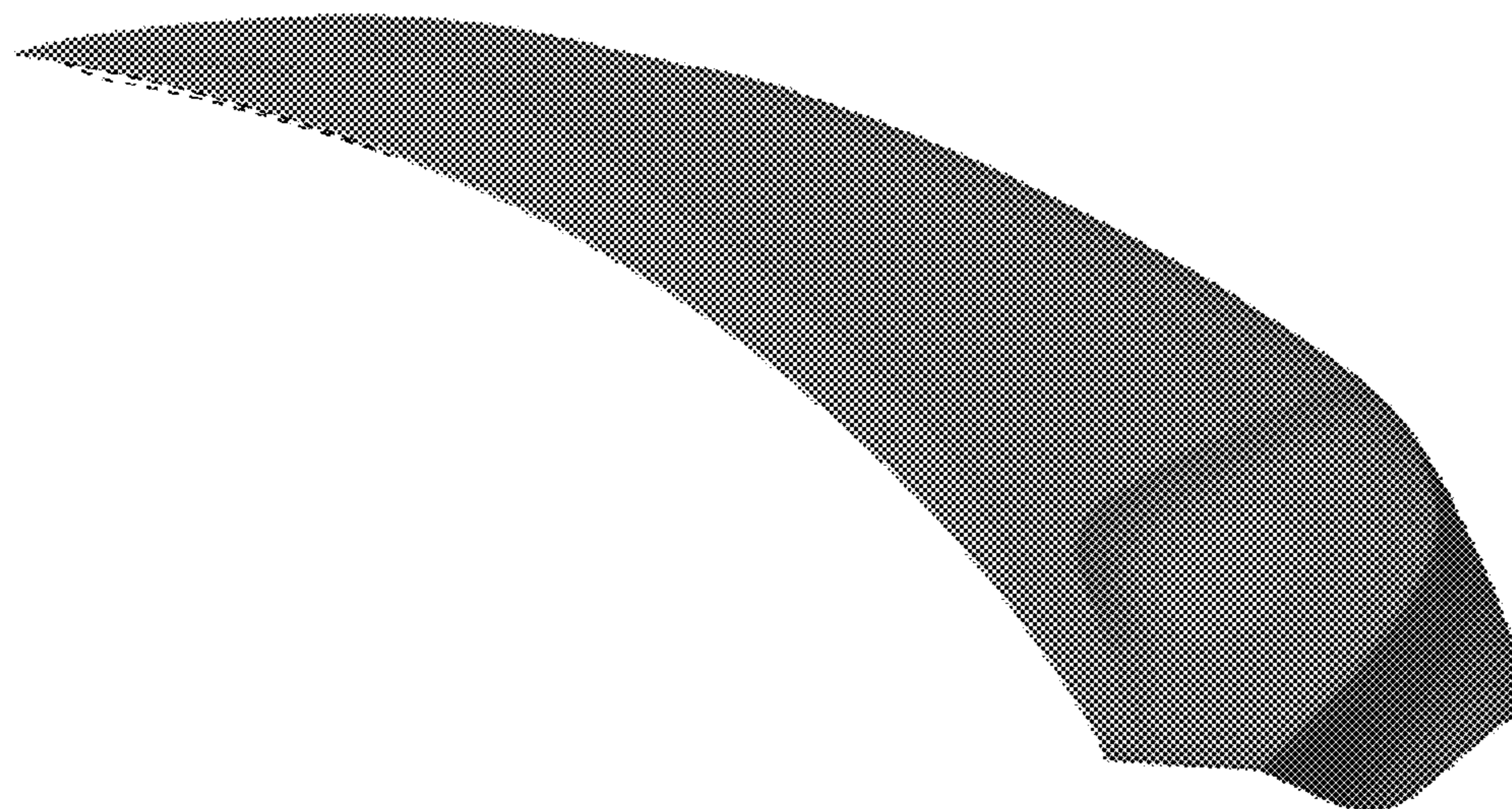
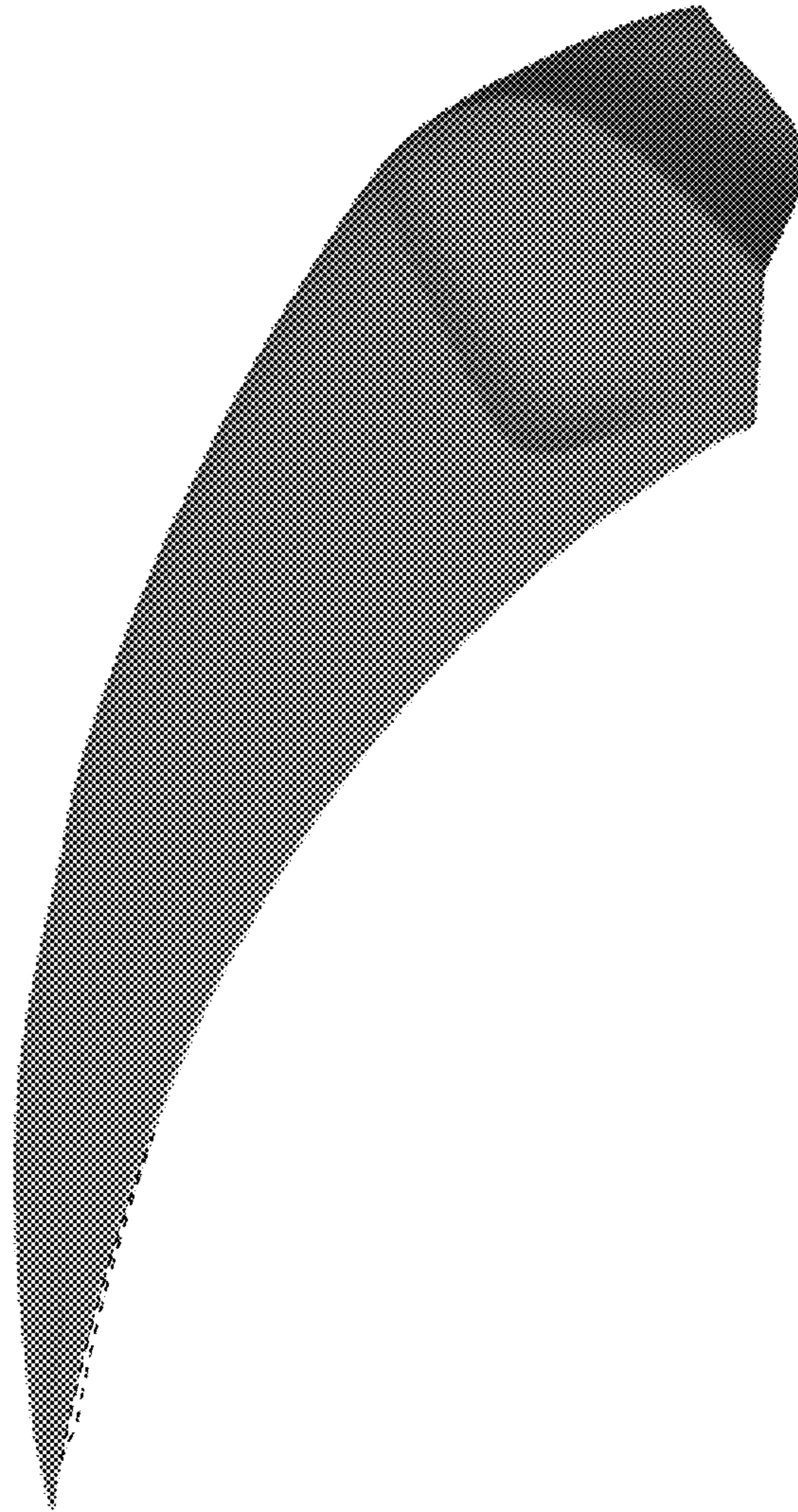

FIG. 1



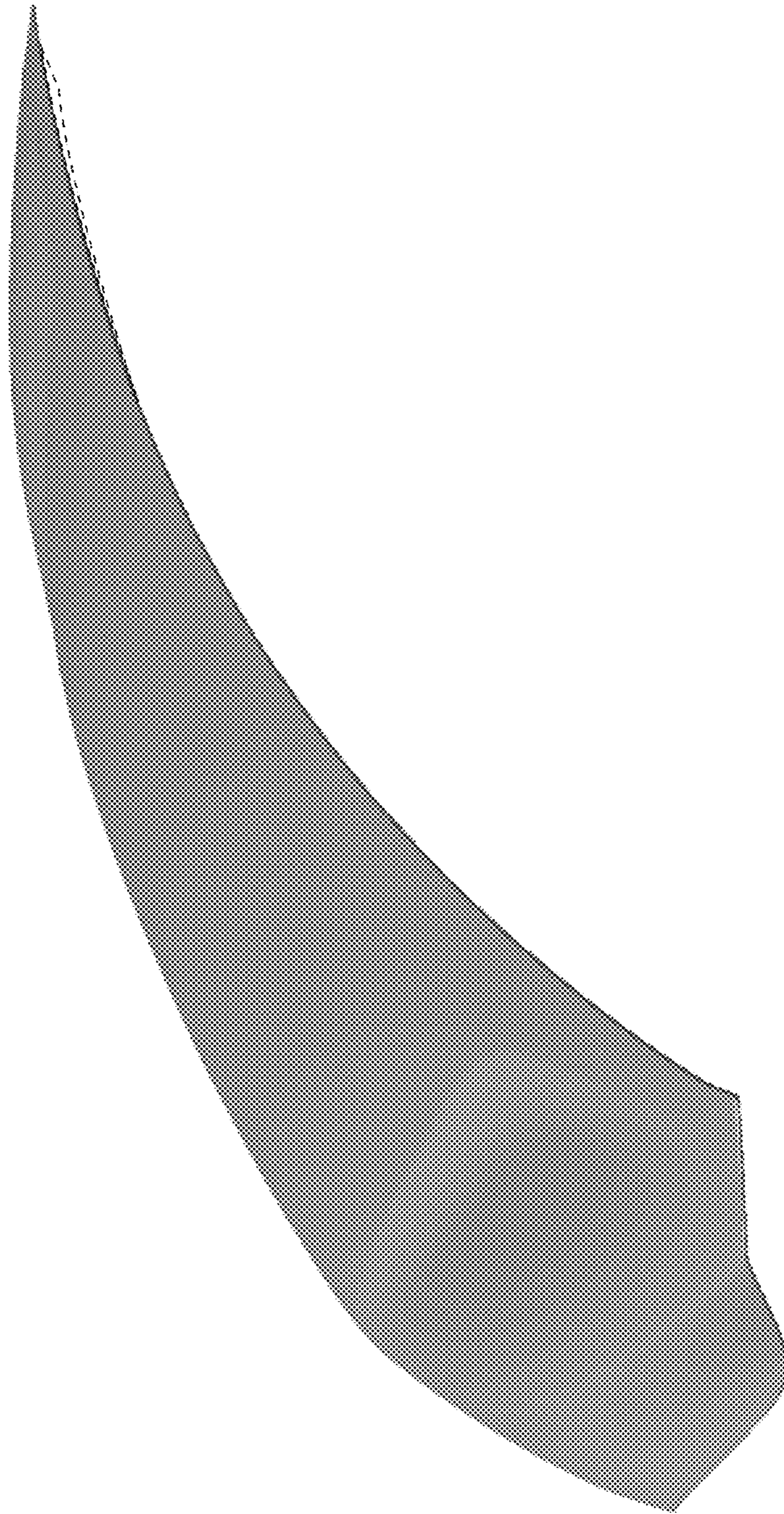

FIG. 2

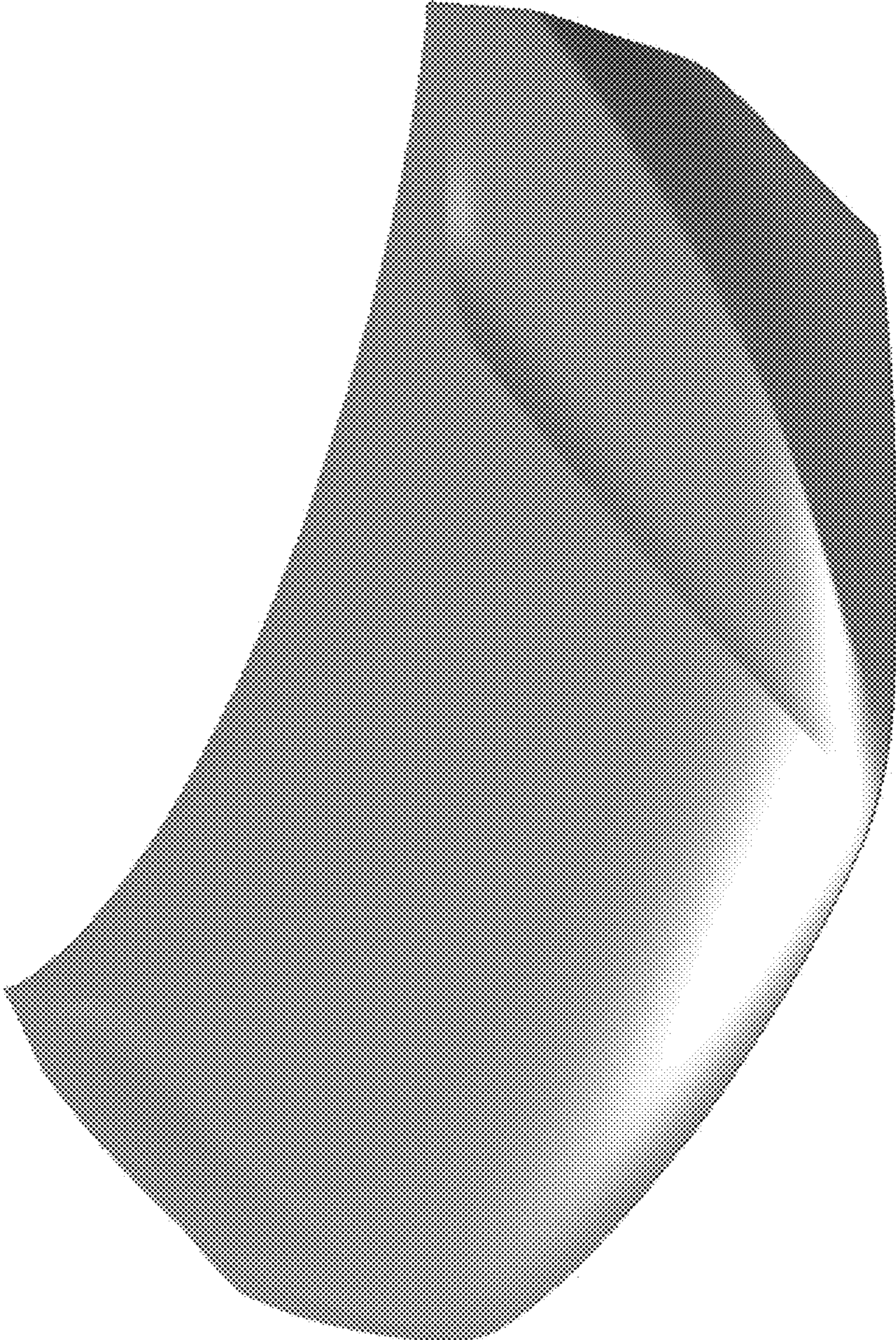

FIG. 3



FIG. 4

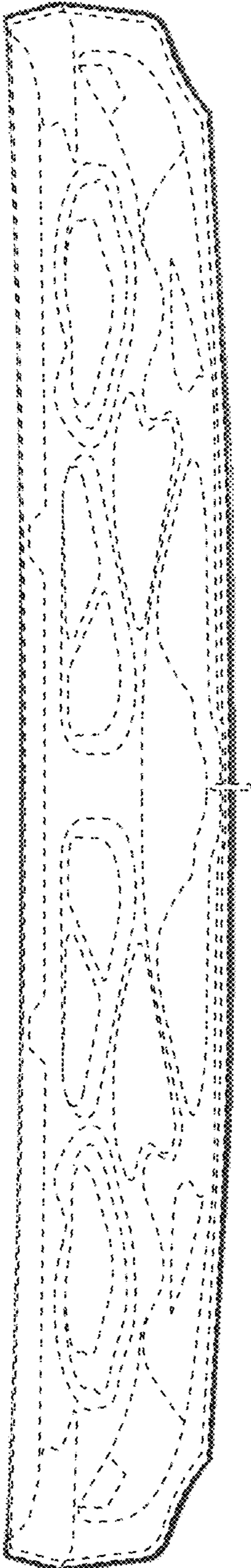

FIG. 5

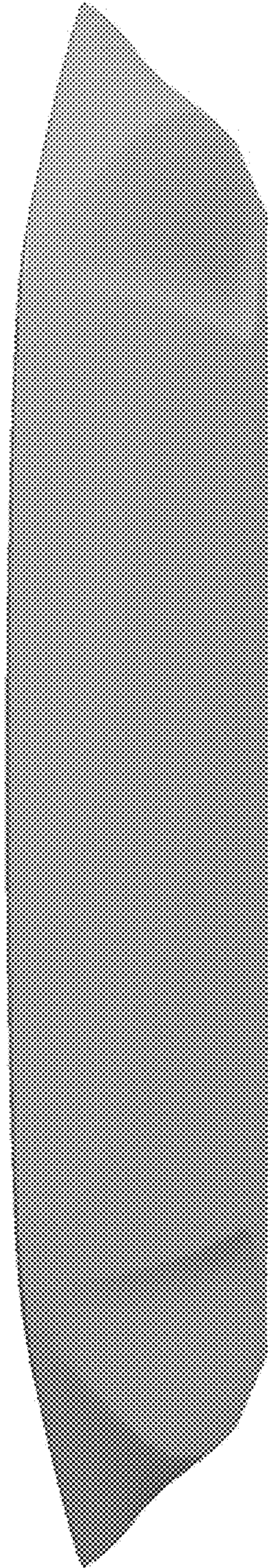

FIG. 6

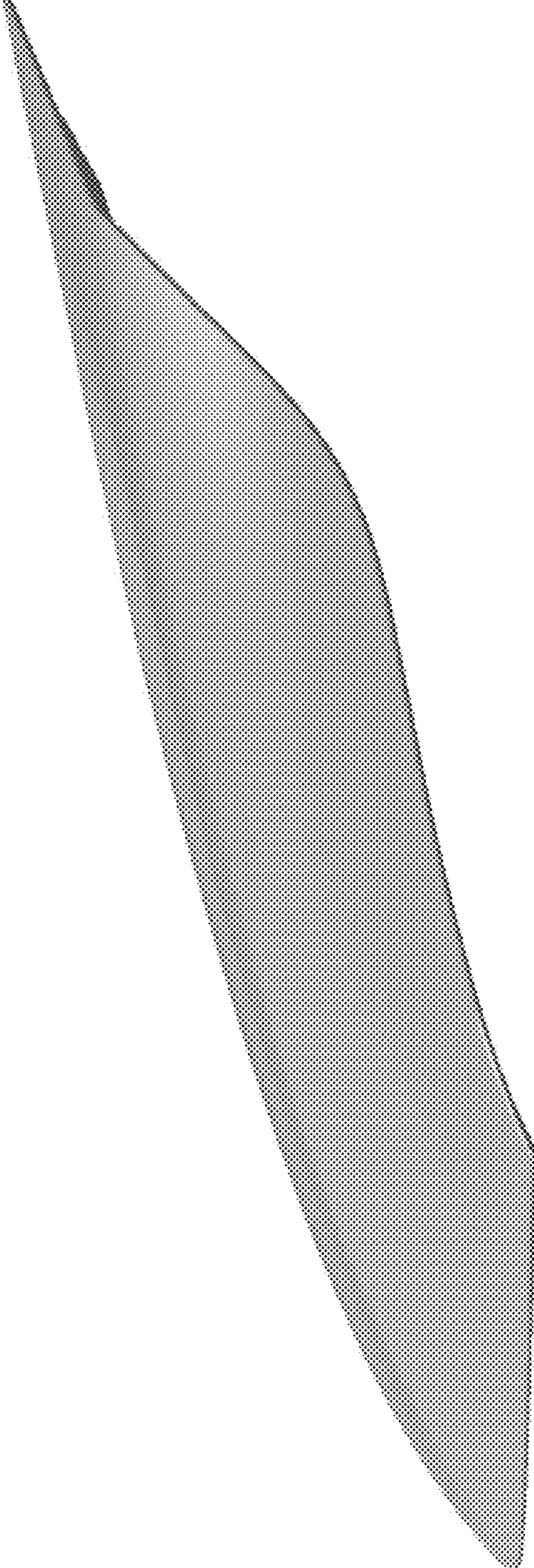

FIG. 7

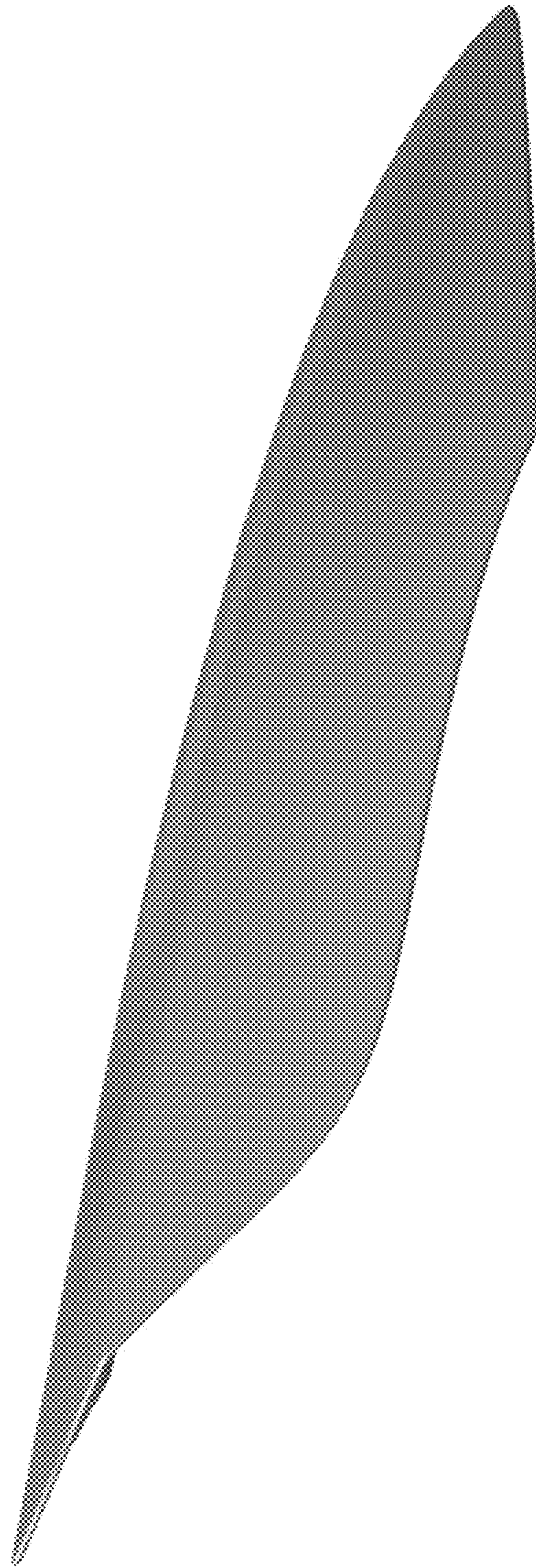

FIG. 8

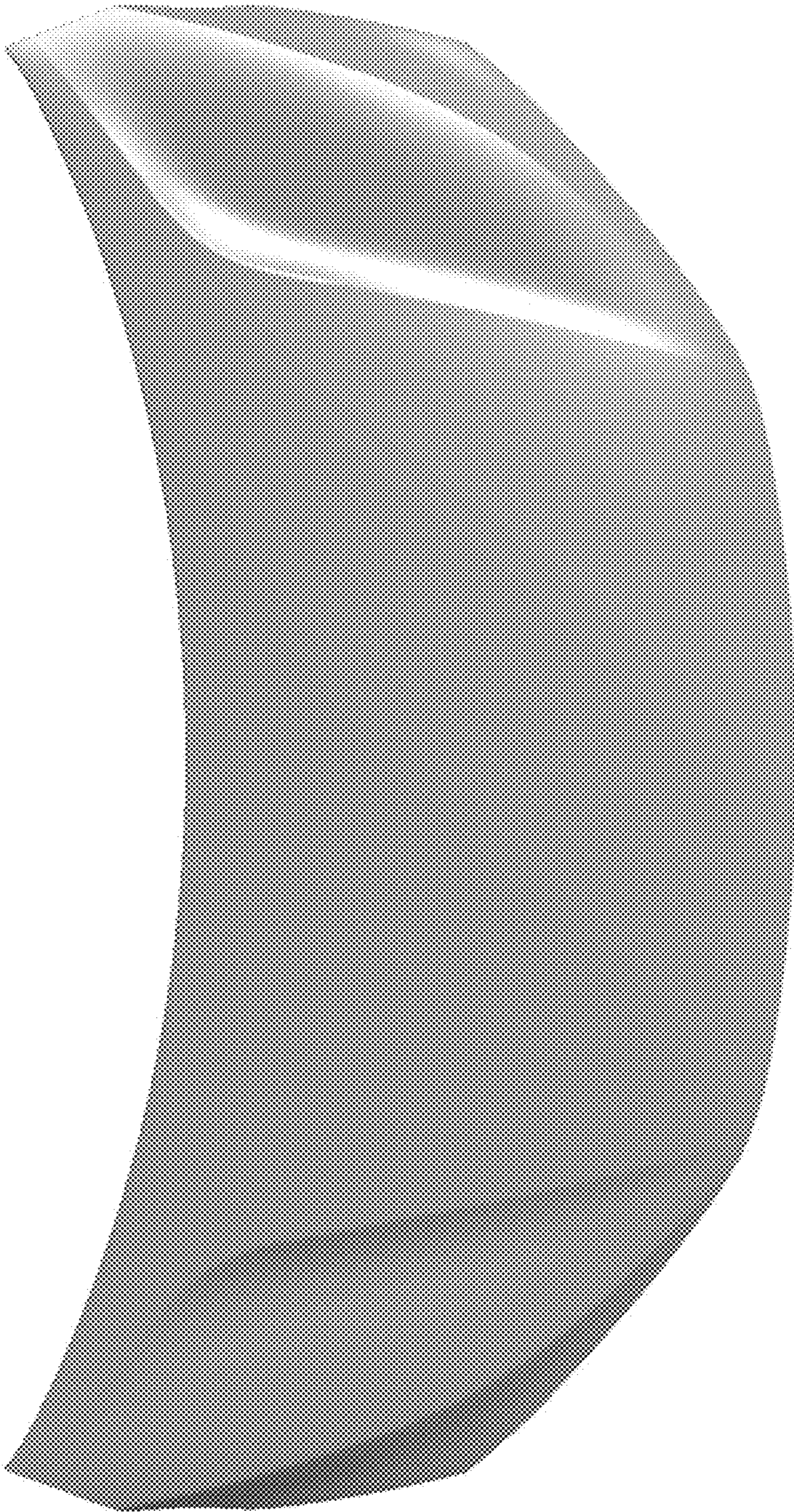

FIG. 9

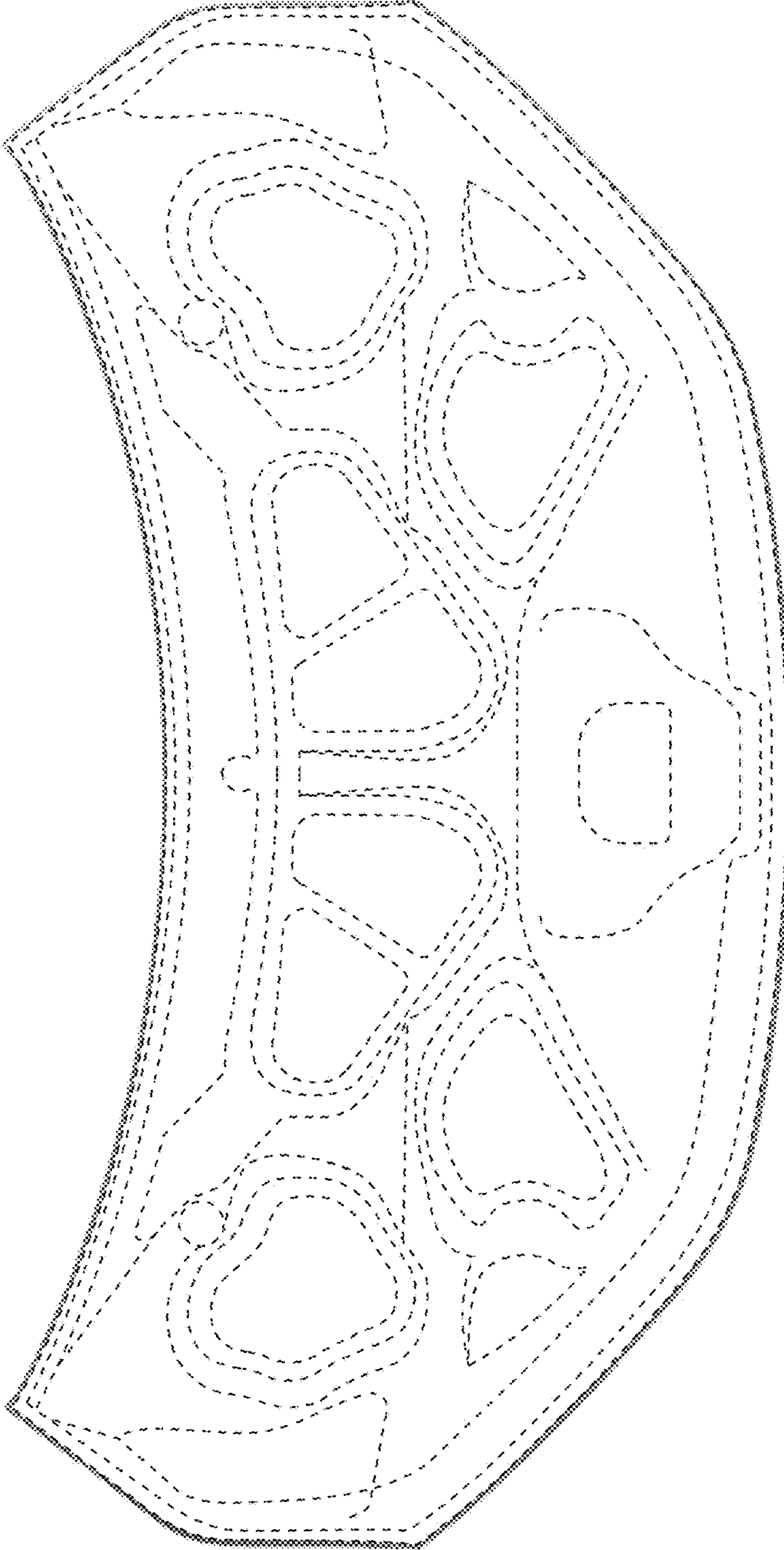

FIG. 10

FIG. 11

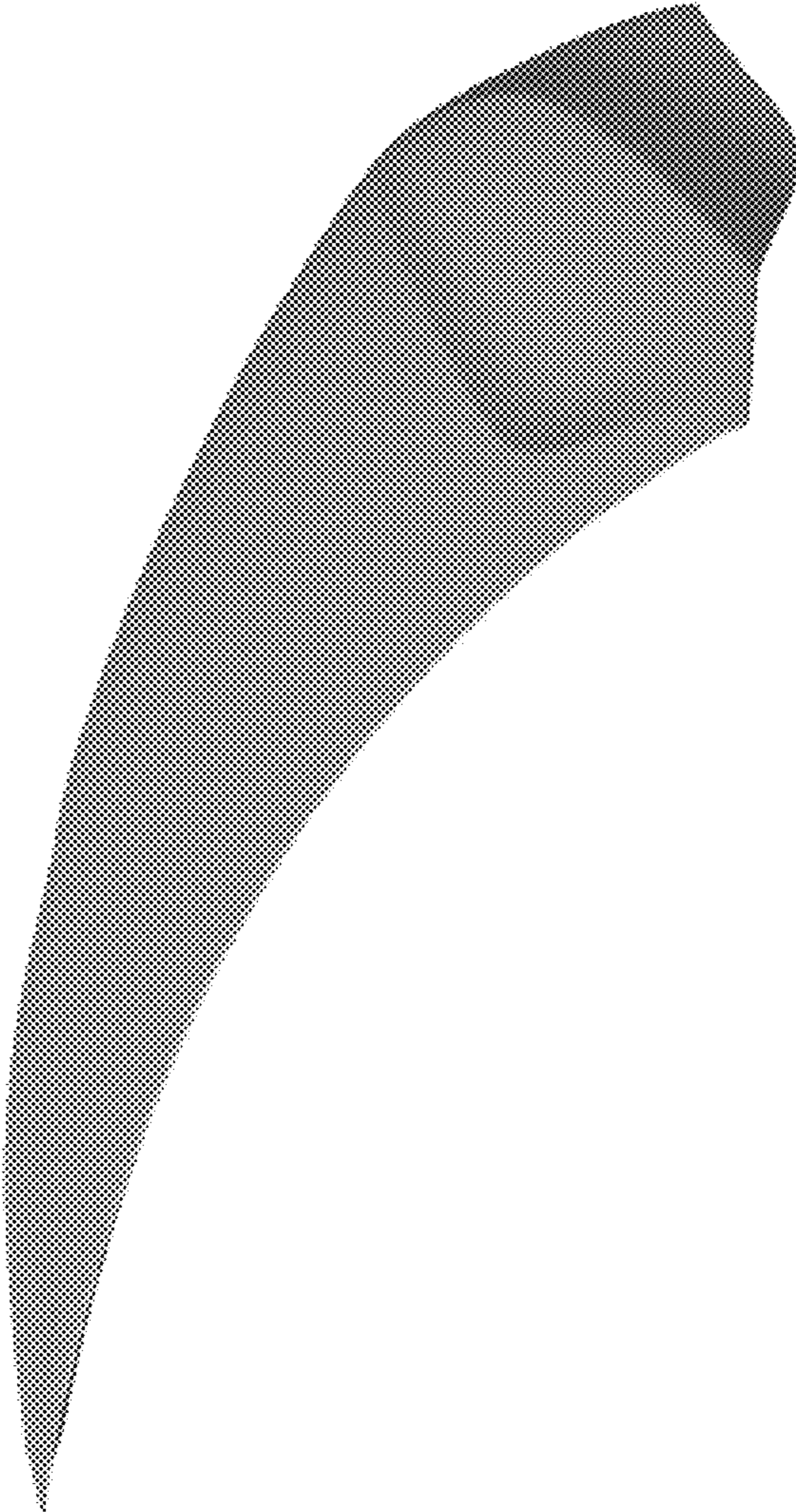
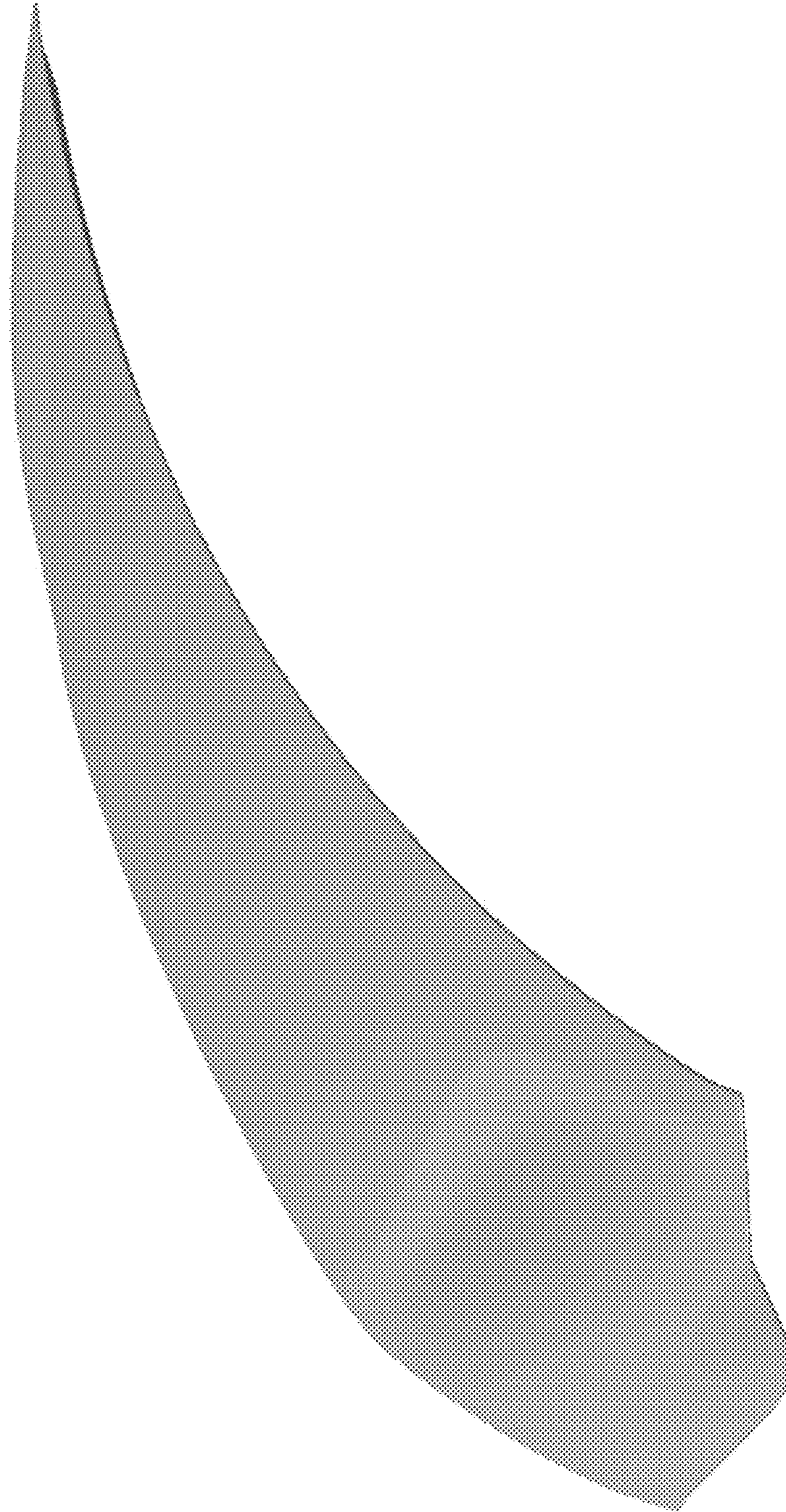

FIG. 12



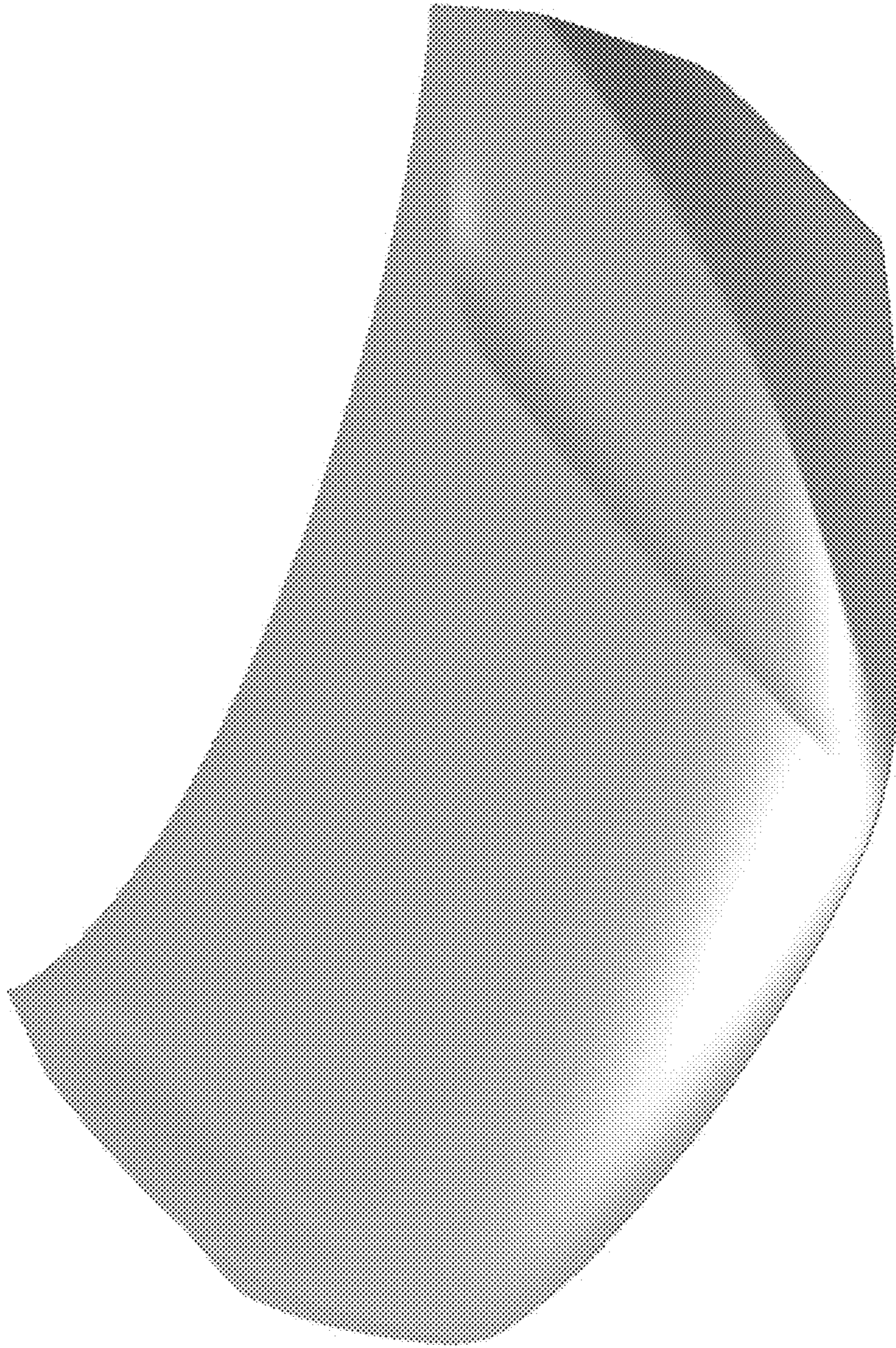

FIG. 13

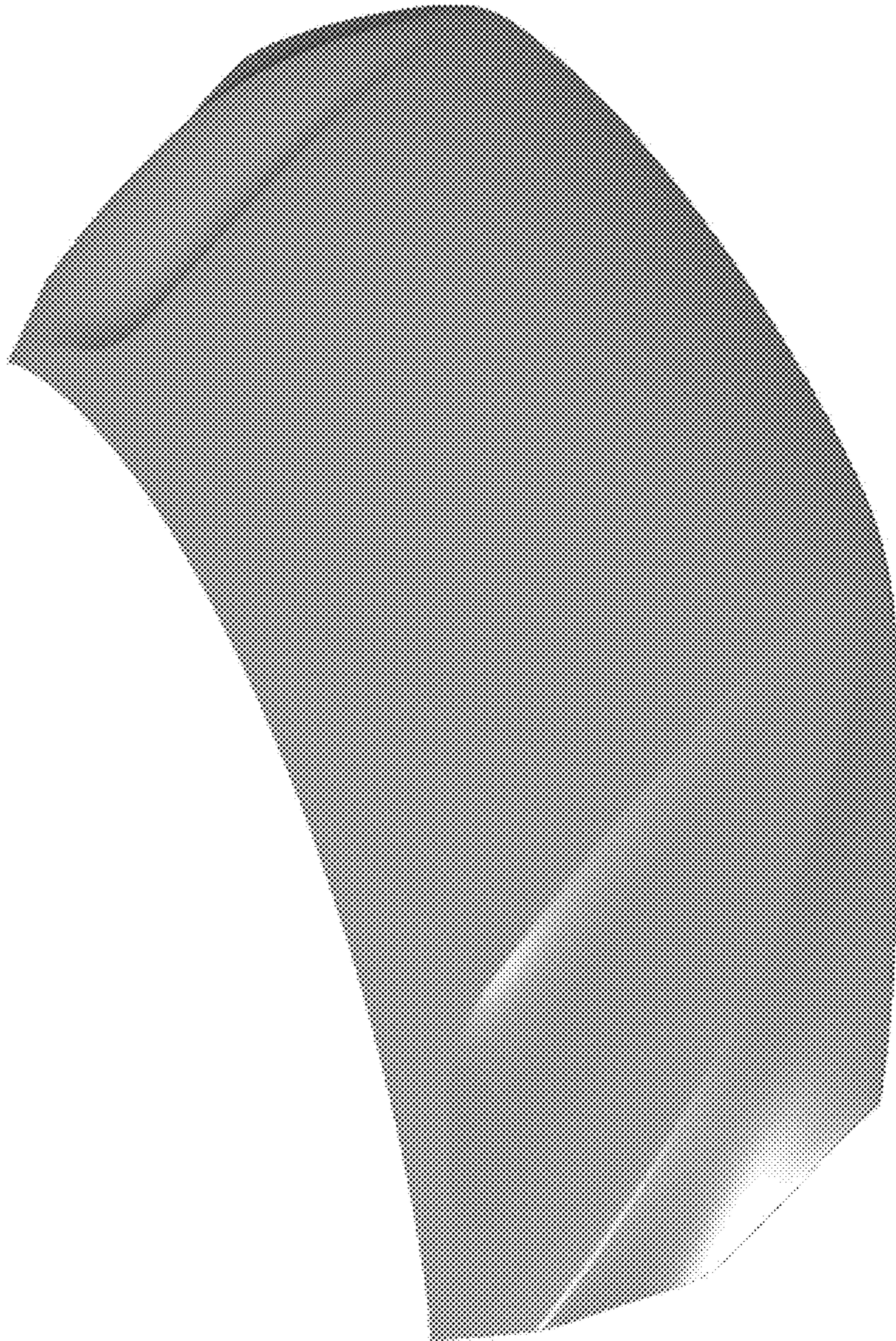

FIG. 14

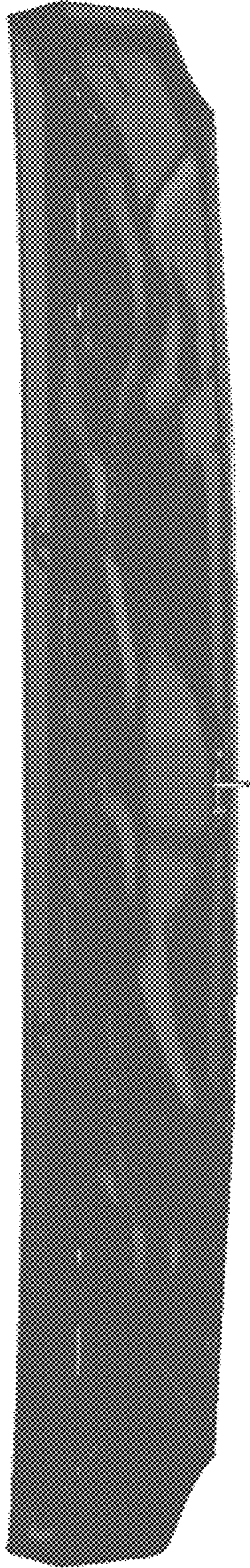

FIG. 15

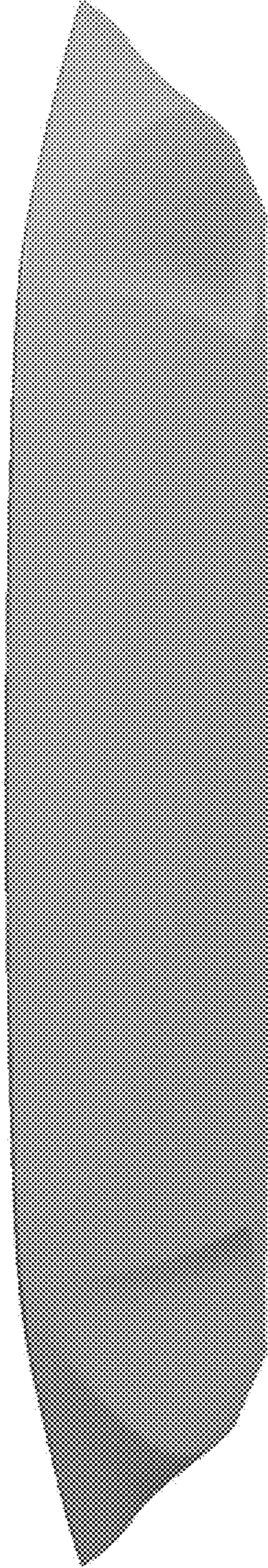

FIG. 16

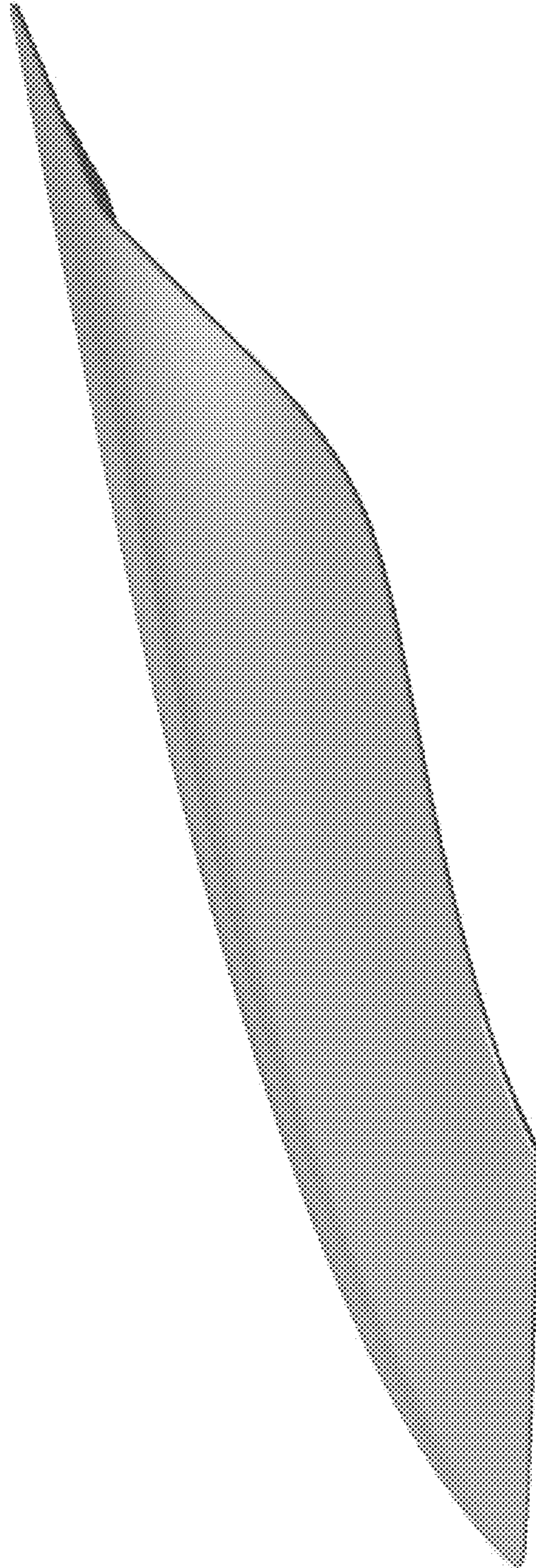

FIG. 17

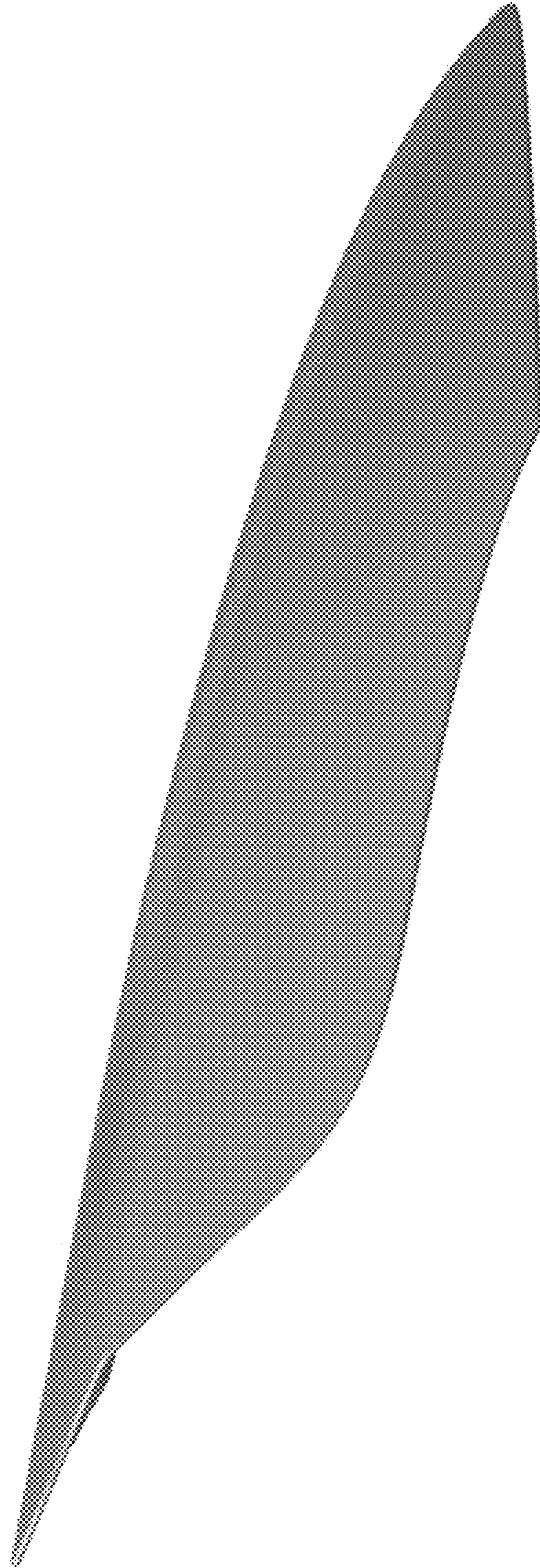

FIG. 18

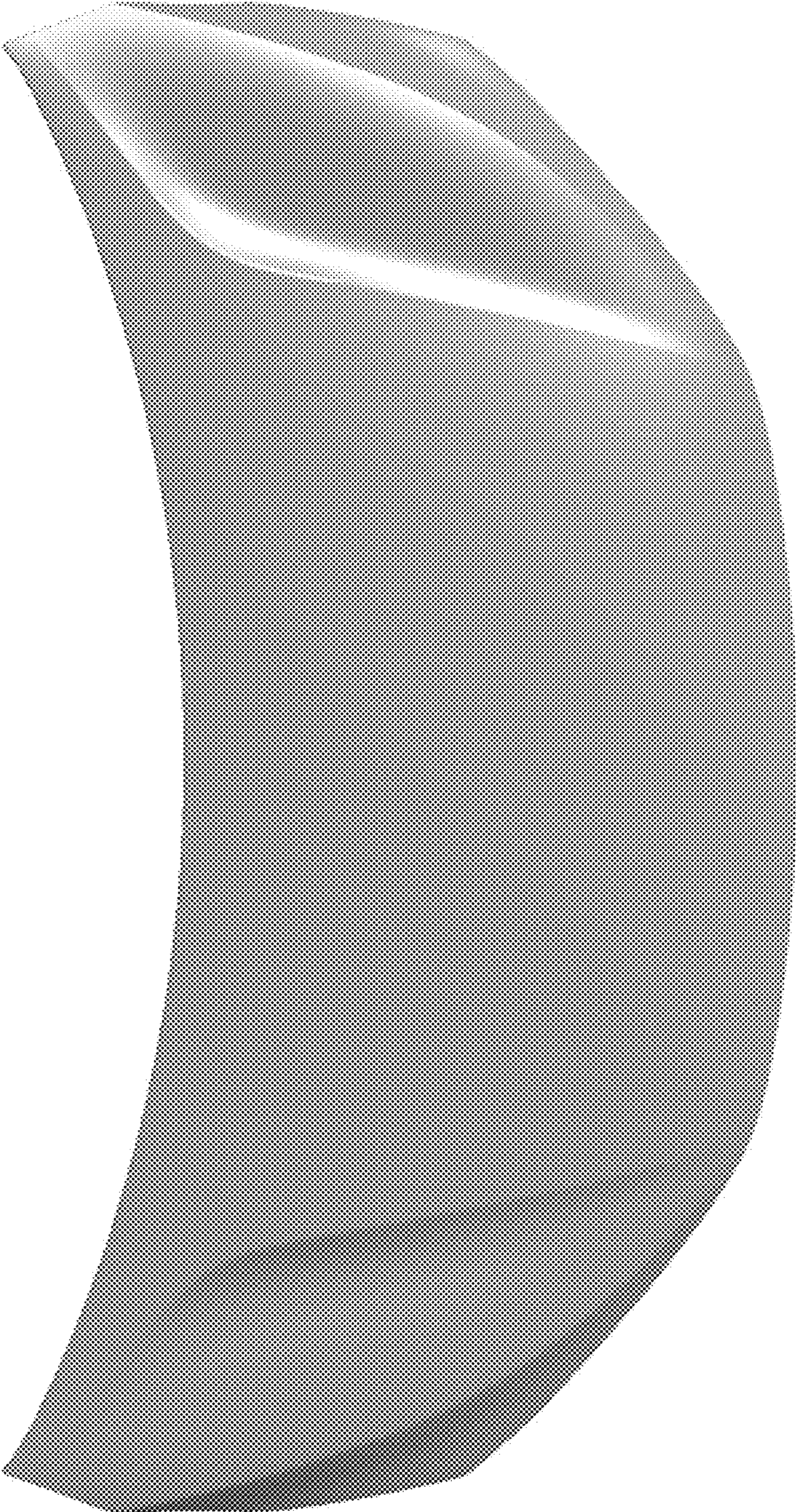

FIG. 19

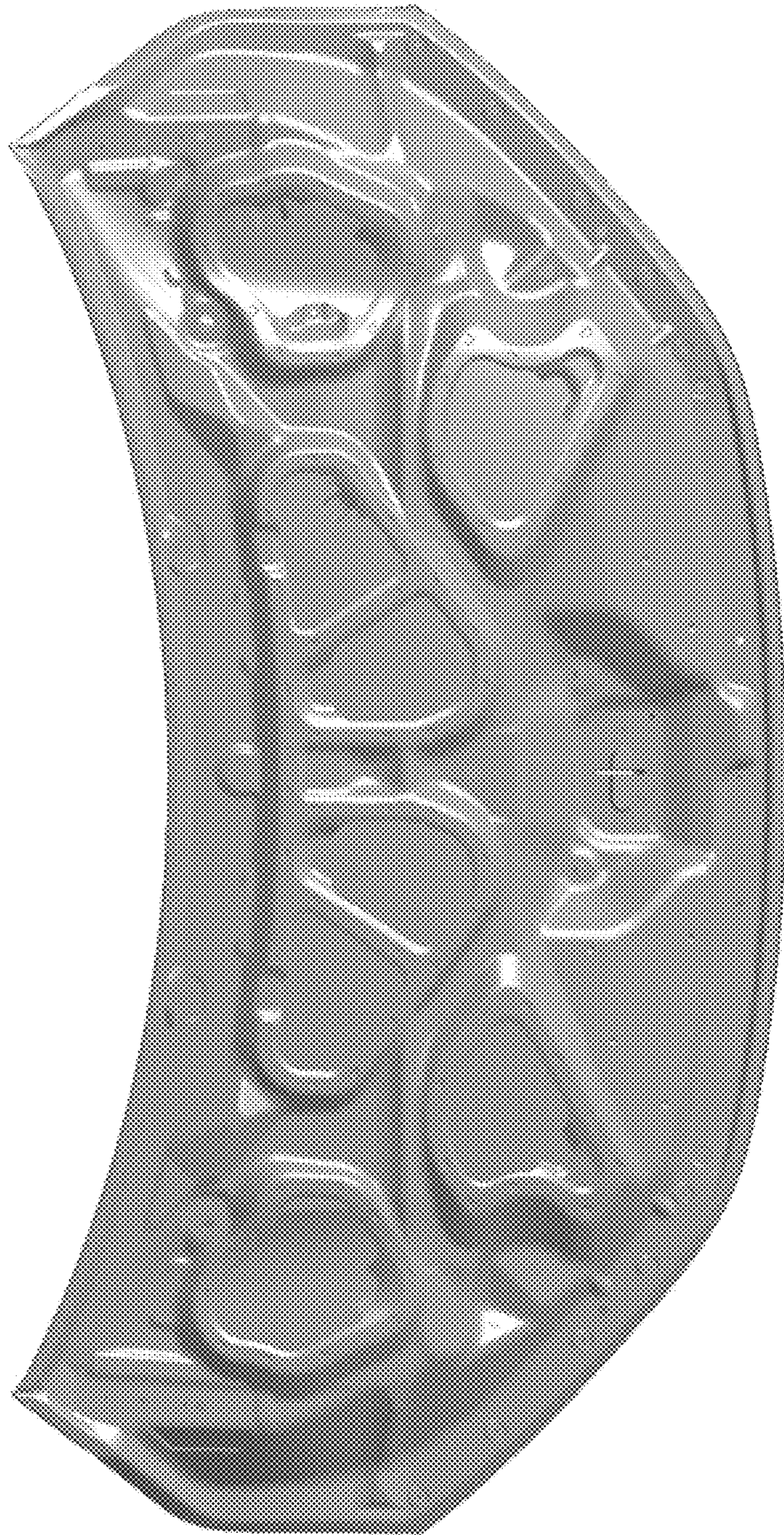

FIG. 20