



US00D865574S

(12) **United States Design Patent** (10) **Patent No.:** **US D865,574 S**
Russell et al. (45) **Date of Patent:** **** Nov. 5, 2019**

(54) **BICYCLE FRAME**
(71) Applicant: **Specialized Bicycle Components, Inc.**,
Morgan Hill, CA (US)
(72) Inventors: **Douglas Graham Russell**, Salinas, CA
(US); **Ingmar Jungnickel**, Morgan Hill,
CA (US); **Yann Duez**, Morgan Hill, CA
(US)
(73) Assignee: **SPECIALIZED BICYCLE**
COMPONENTS, INC., Morgan Hill,
CA (US)

(**) Term: **15 Years**

(21) Appl. No.: **29/639,588**

(22) Filed: **Mar. 7, 2018**

(51) **LOC (12) Cl.** **12-11**

(52) **U.S. Cl.**
USPC **D12/111**

(58) **Field of Classification Search**
USPC D12/111, 117; D21/412, 414, 419,
D21/423-428, 431-435
CPC B62K 3/00; B62K 3/02; B62K 3/06
See application file for complete search history.

(56) **References Cited**

U.S. PATENT DOCUMENTS

D343,600 S * 1/1994 Moore D12/111
D405,030 S * 2/1999 Frost D12/111
6,497,427 B1 * 12/2002 D'Alusio B62K 3/04
280/288
6,889,992 B2 * 5/2005 Vroomen B62K 19/00
280/274

D523,380 S * 6/2006 Auger D12/111
D635,894 S * 4/2011 Argote Vivar D12/111
D662,011 S 6/2012 D'Alusio et al.
D719,488 S * 12/2014 Stafford D12/111
D719,880 S * 12/2014 Juarez D12/111
D725,552 S * 3/2015 Lawson D12/111
D726,075 S 4/2015 D'Alusio et al.
D734,218 S 7/2015 D'Alusio et al.
D734,692 S * 7/2015 D'Alusio D12/111
D774,970 S * 12/2016 D'Alusio D12/111
D802,487 S * 11/2017 Petrov D12/111
2010/0225090 A1 * 9/2010 Cusack B62K 19/02
280/281.1

* cited by examiner

Primary Examiner — Darlington Ly
(74) *Attorney, Agent, or Firm* — Michael Best &
Friedrich LLP

(57) **CLAIM**

We claim the ornamental design for a bicycle frame, as shown and described.

DESCRIPTION

FIG. 1 is a rear and right side perspective view of a bicycle frame showing our new design;
FIG. 2 is a rear elevation view thereof;
FIG. 3 is a front elevation view thereof;
FIG. 4 is a left side elevation view thereof;
FIG. 5 is a right side elevation view thereof;
FIG. 6 is a top plan view thereof; and,
FIG. 7 is a bottom plan view thereof.
The broken lines in the drawings illustrate portions of the bicycle frame that form no part of the claimed design.

1 Claim, 5 Drawing Sheets

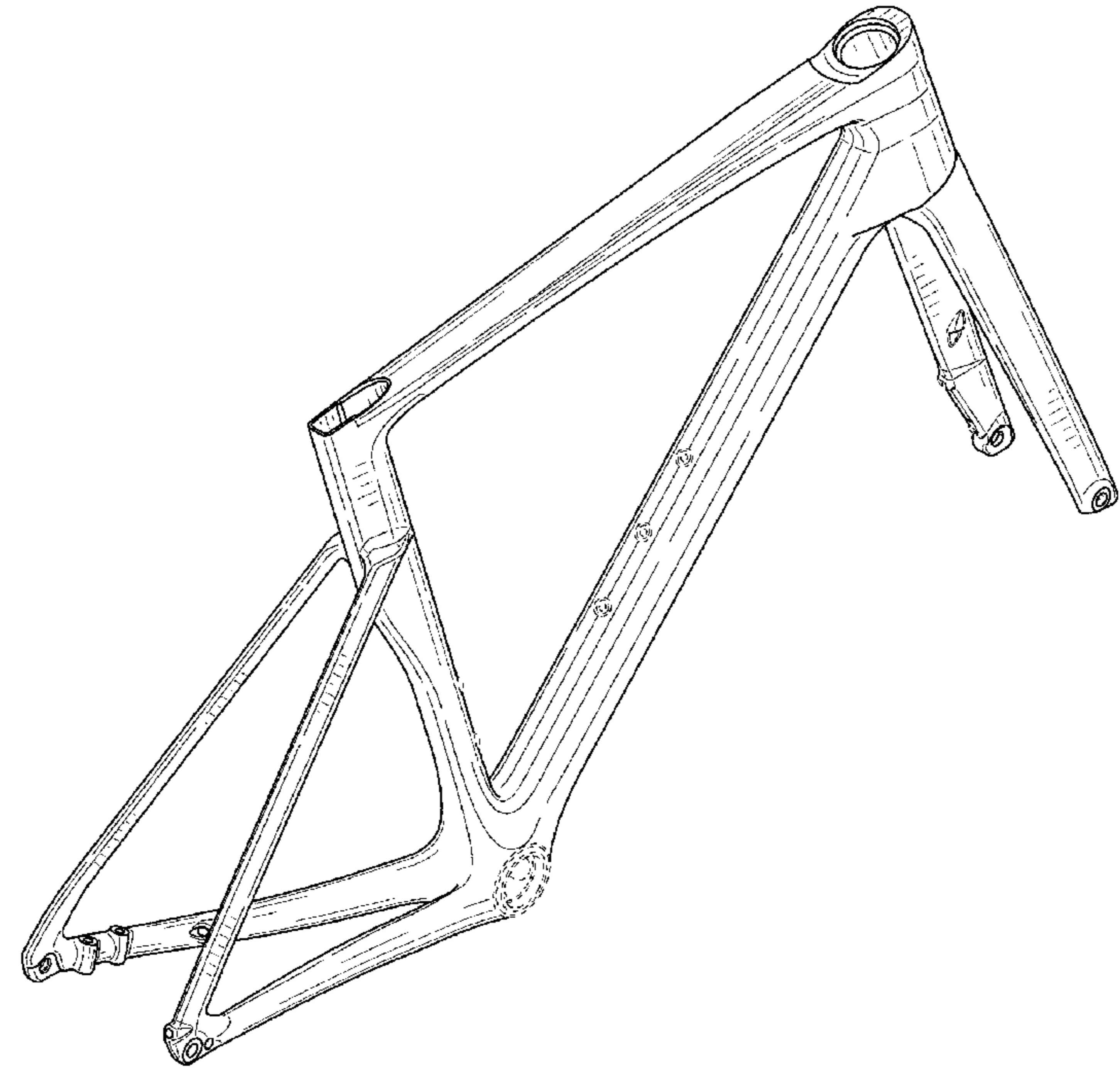

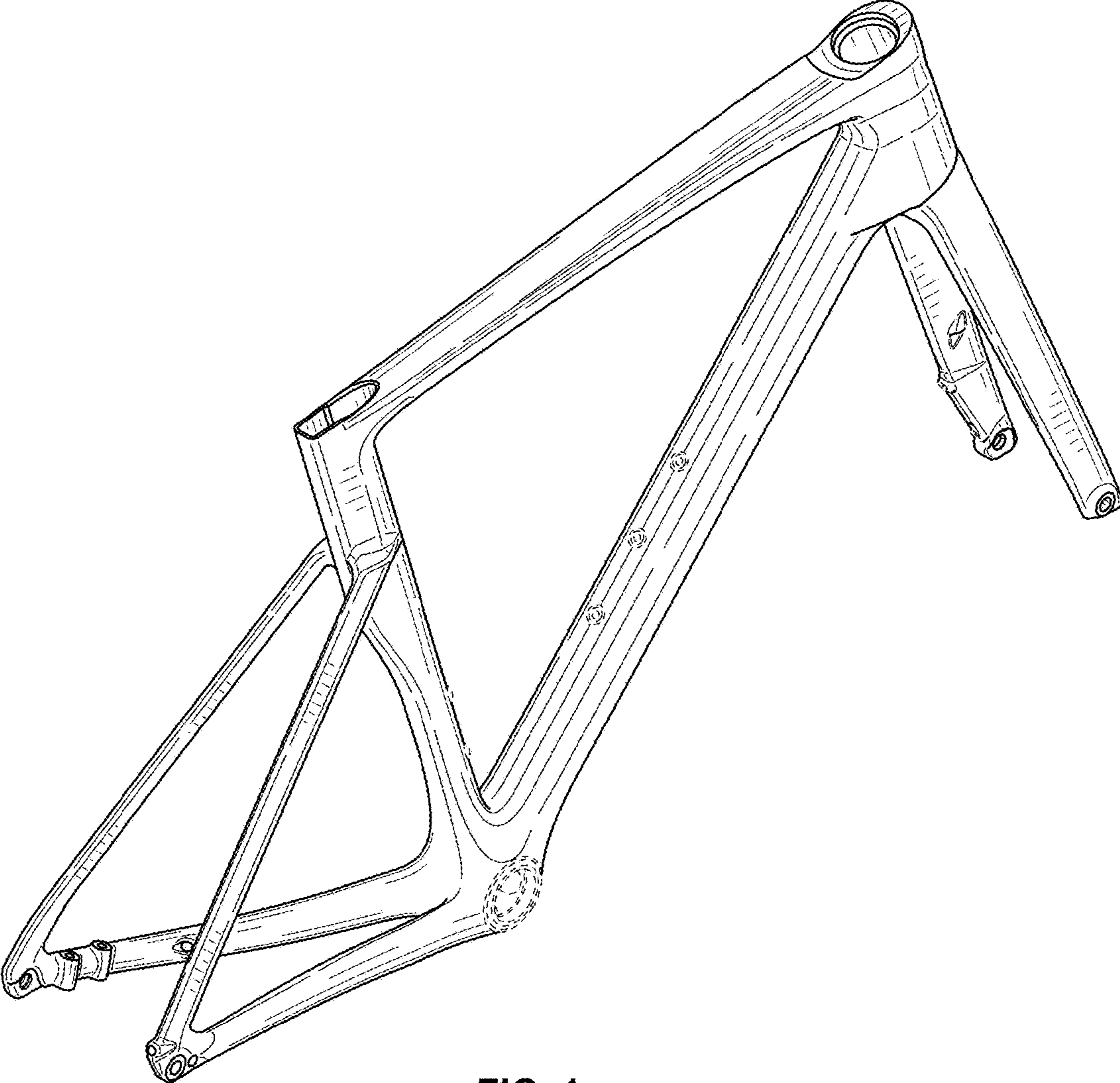

FIG. 1

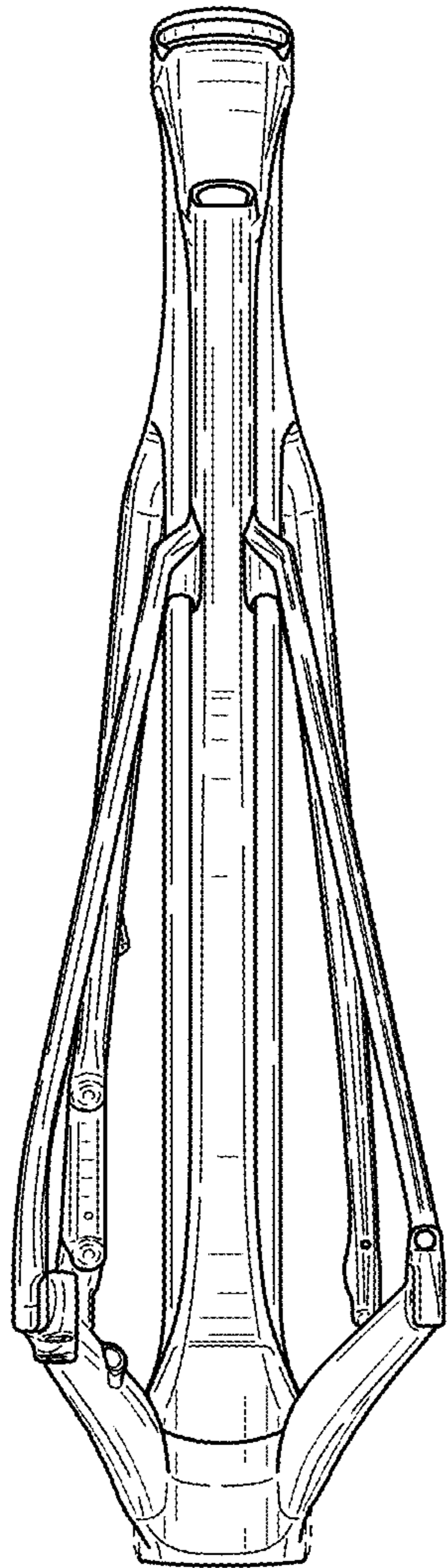

FIG. 2

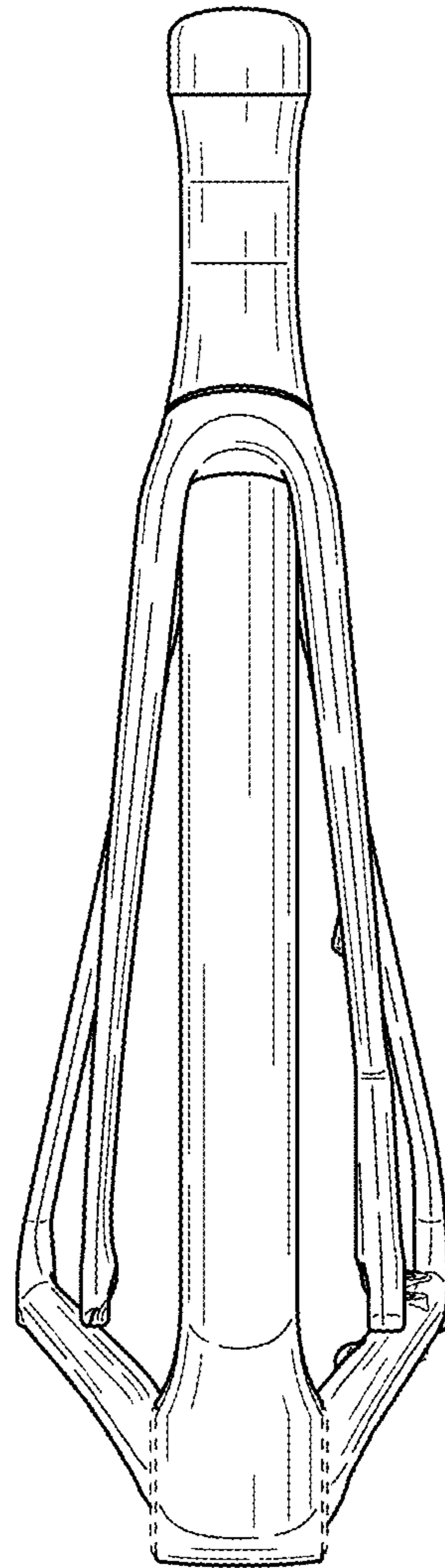

FIG. 3

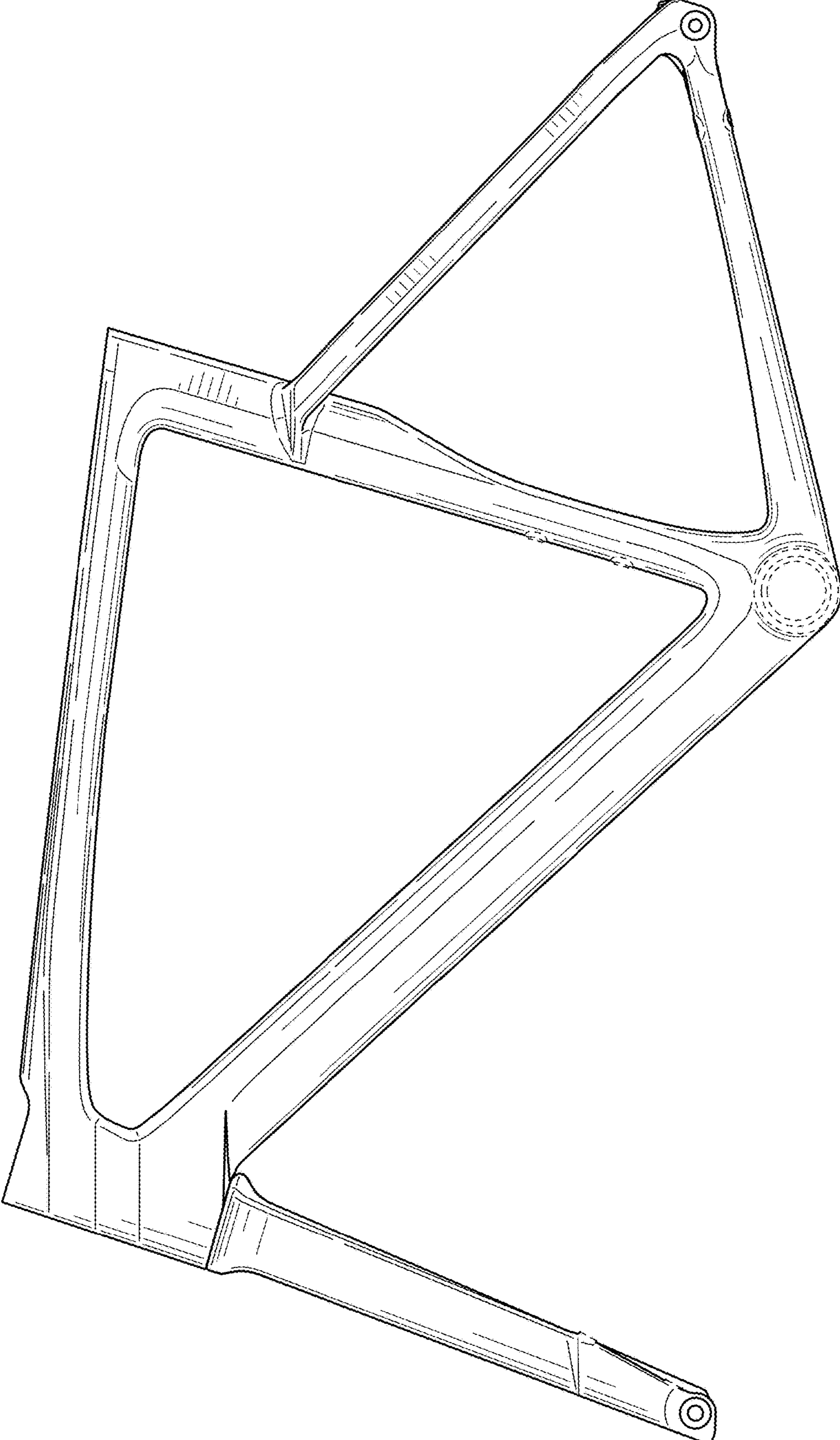

FIG. 4

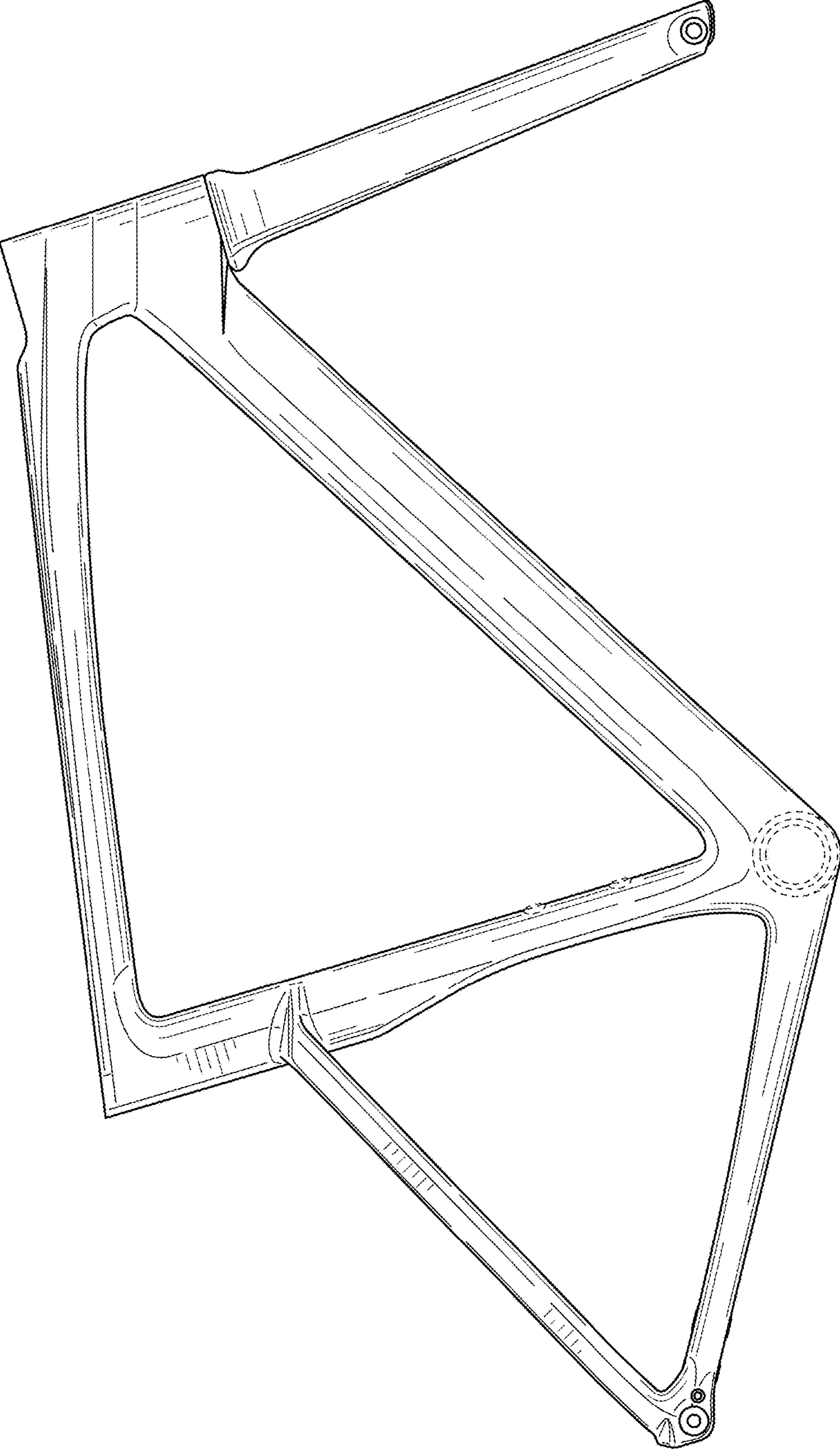

FIG. 5

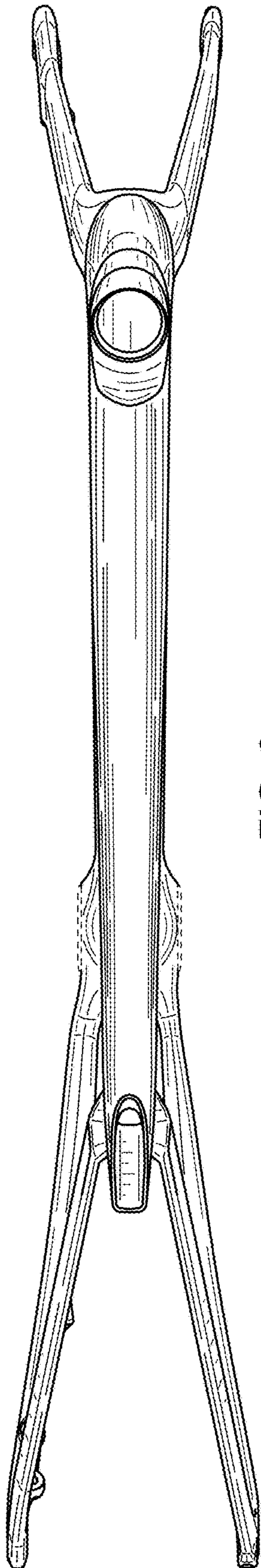

FIG. 6

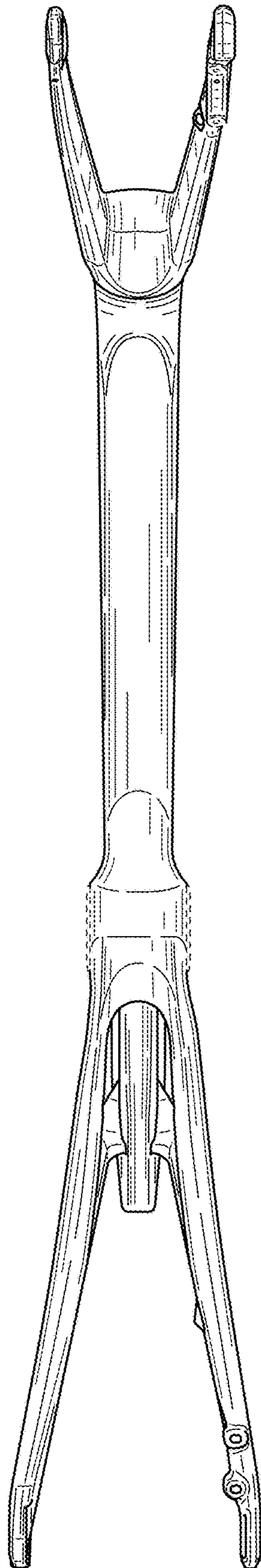

FIG. 7