



US00D865564S

(12) **United States Design Patent** (10) **Patent No.:** **US D865,564 S**
Sahara et al. (45) **Date of Patent:** **** Nov. 5, 2019**

(54) **AUTOMOBILE**

(71) Applicant: **HONDA MOTOR CO., LTD.**, Tokyo (JP)

(72) Inventors: **Ken Sahara**, Saitama (JP); **Yuji Terui**, Saitama (JP)

(73) Assignee: **HONDA MOTOR CO., LTD.**, Tokyo (JP)

(**) Term: **15 Years**

(21) Appl. No.: **29/639,421**

(22) Filed: **Mar. 6, 2018**

(30) **Foreign Application Priority Data**

Sep. 8, 2017 (JP) 2017-019525

(51) **LOC (12) Cl.** **12-08**

(52) **U.S. Cl.**
USPC **D12/90**

(58) **Field of Classification Search**
USPC D12/86, 90-92, 88; D21/424, 433, 434, D21/533; 296/181.1-181.5, 183.1
CPC B62D 25/00; B62D 25/06; B62D 33/00; B62D 35/00

See application file for complete search history.

(56) **References Cited**

U.S. PATENT DOCUMENTS

D622,183 S *	8/2010	Ishikura	D12/90
D700,104 S *	2/2014	Malachowski	D12/90
D826,782 S *	8/2018	Goeppel	D12/91
D837,098 S *	1/2019	Strunz	D12/91

* cited by examiner

Primary Examiner — Melody N Brown

(74) *Attorney, Agent, or Firm* — Westerman, Hattori, Daniels & Adrian, LLP

(57) **CLAIM**

The ornamental design for an automobile, as shown and described.

DESCRIPTION

FIG. 1 is a left side perspective view of an automobile;
FIG. 2 is a right side perspective view thereof;
FIG. 3 is a front view thereof;
FIG. 4 is a rear view thereof;
FIG. 5 is a left side view thereof;
FIG. 6 is a right side view thereof; and,
FIG. 7 is a top plan view thereof.

The broken lines in the drawings illustrate portions of the automobile that form no part of the claimed design.

1 Claim, 7 Drawing Sheets

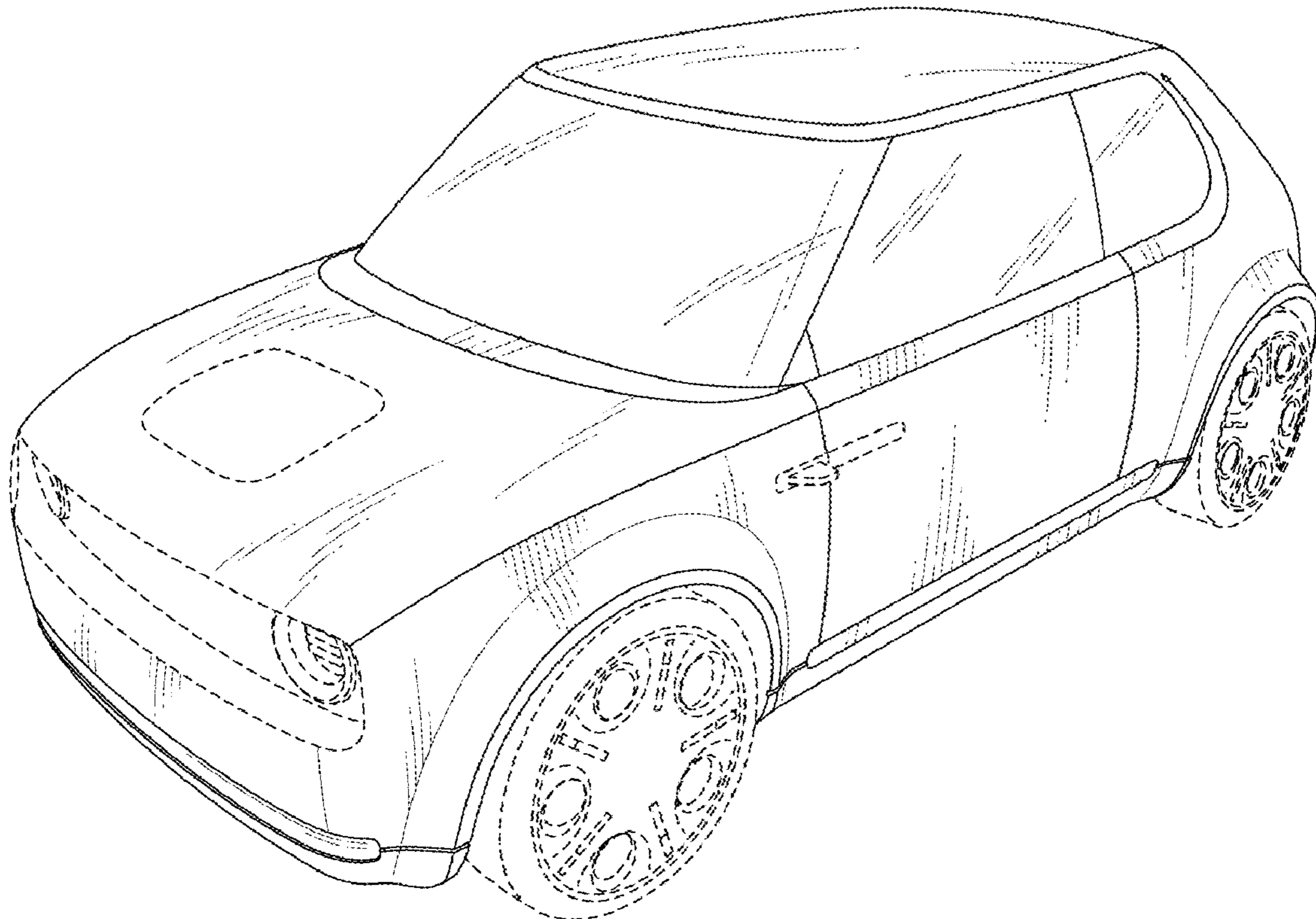

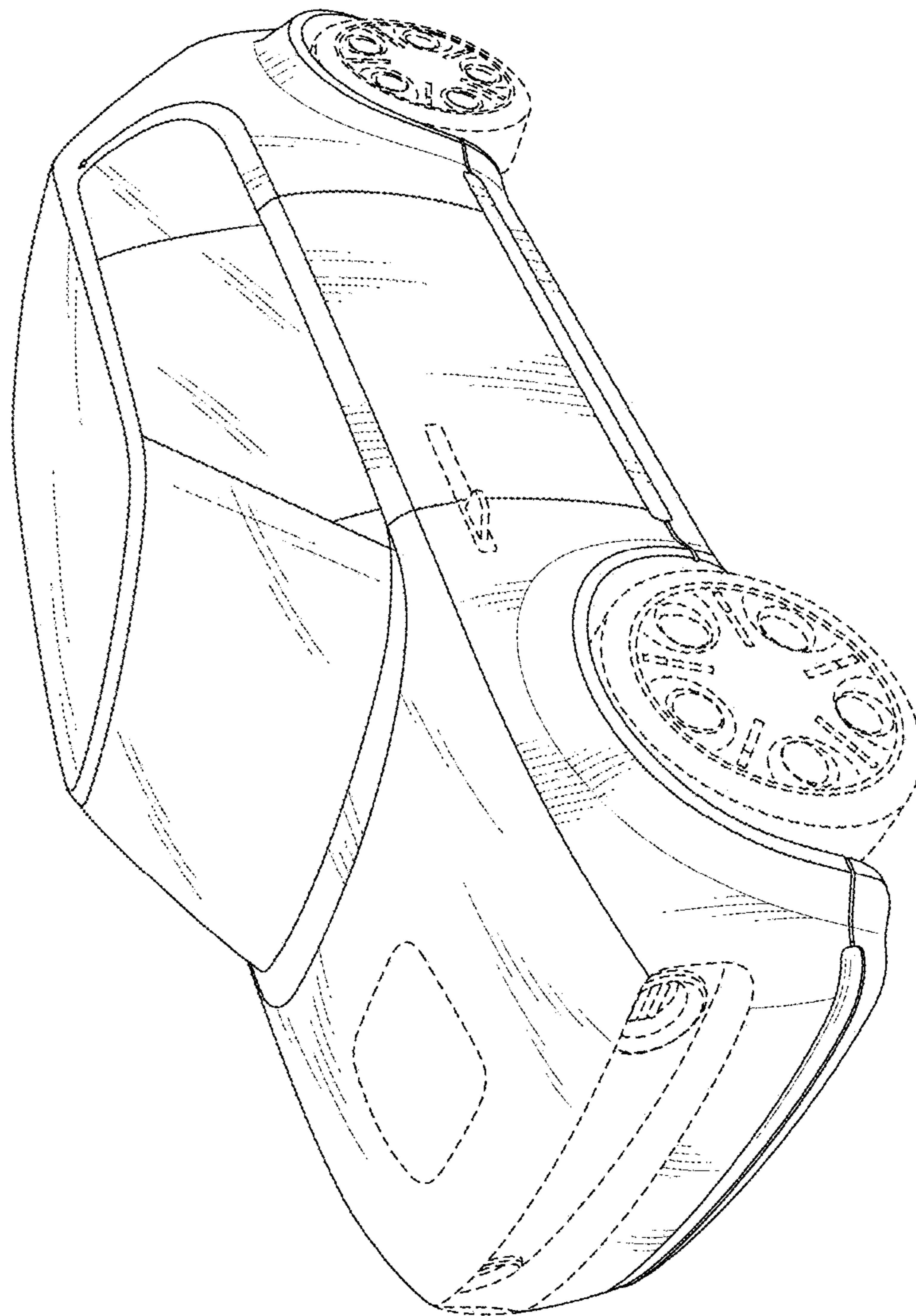

FIG. 1

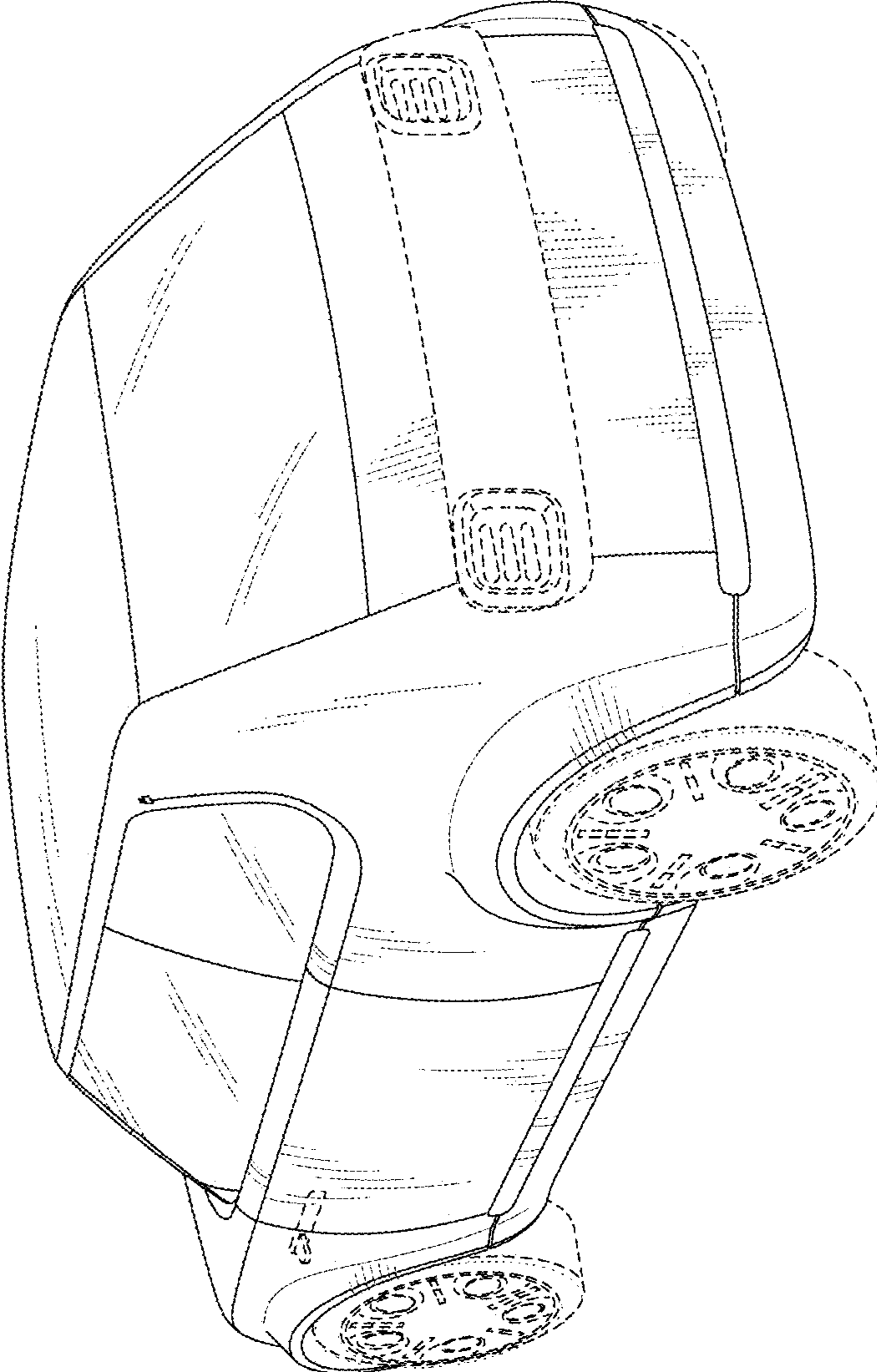

FIG. 2

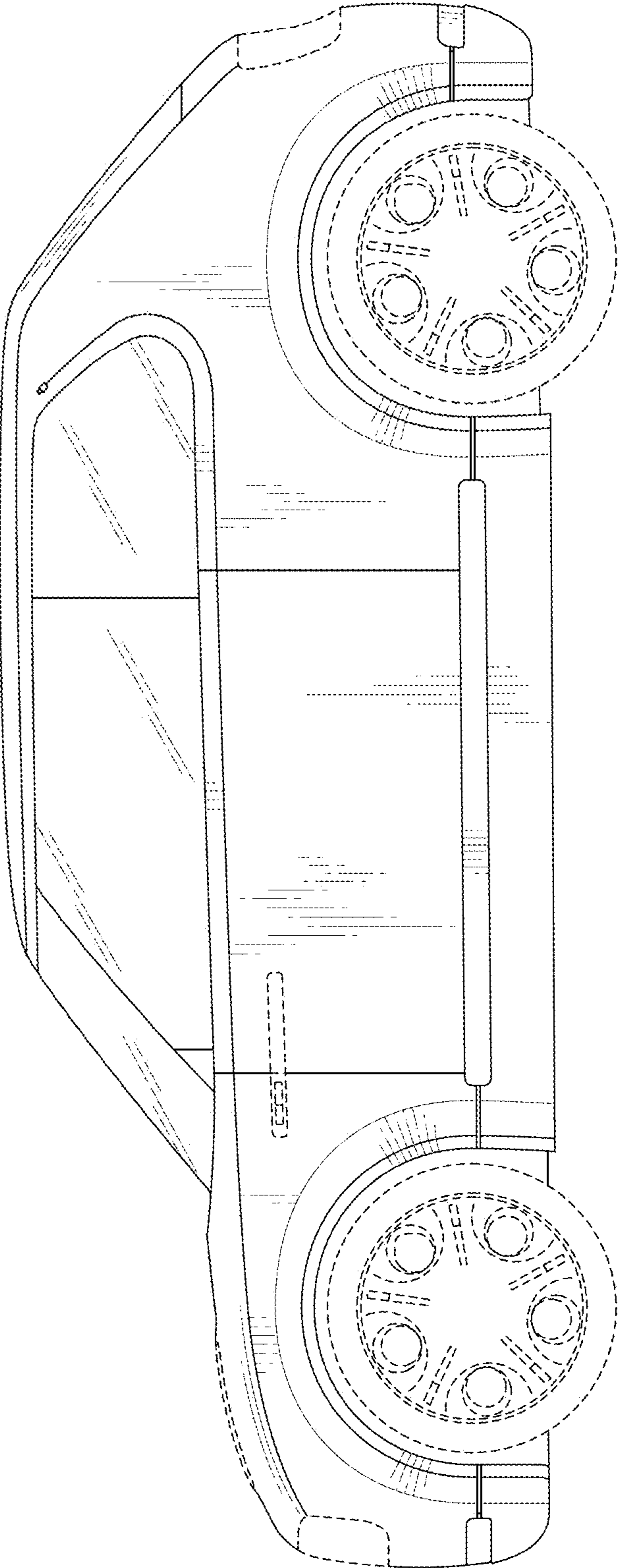

FIG. 3

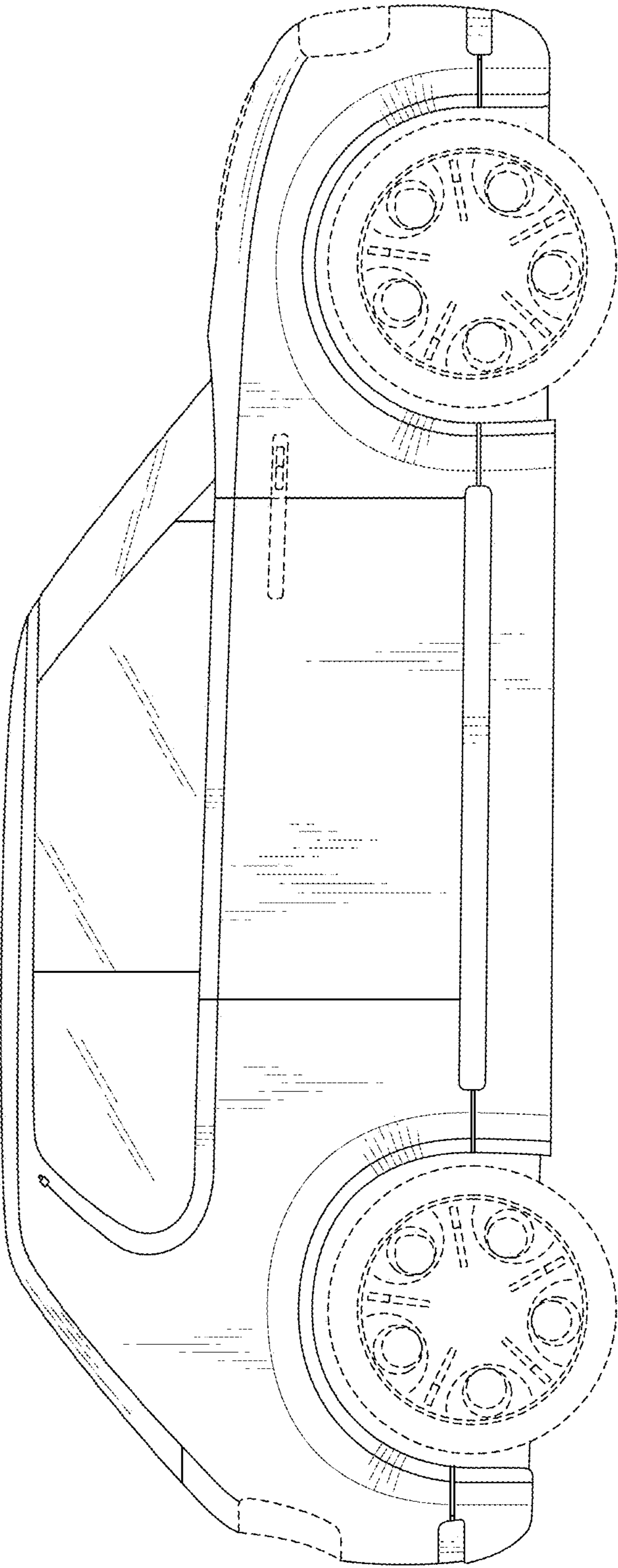

FIG. 4

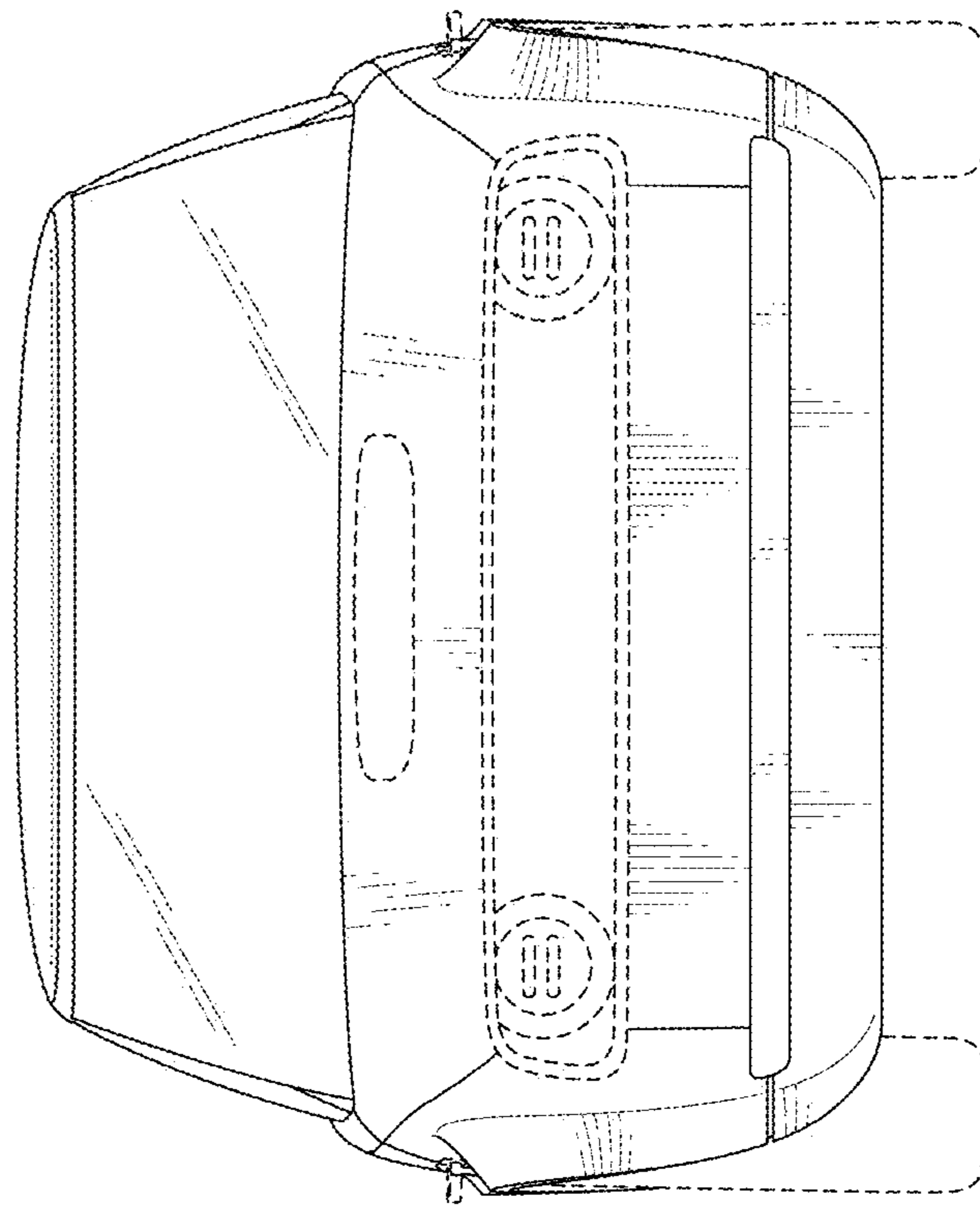

FIG. 5

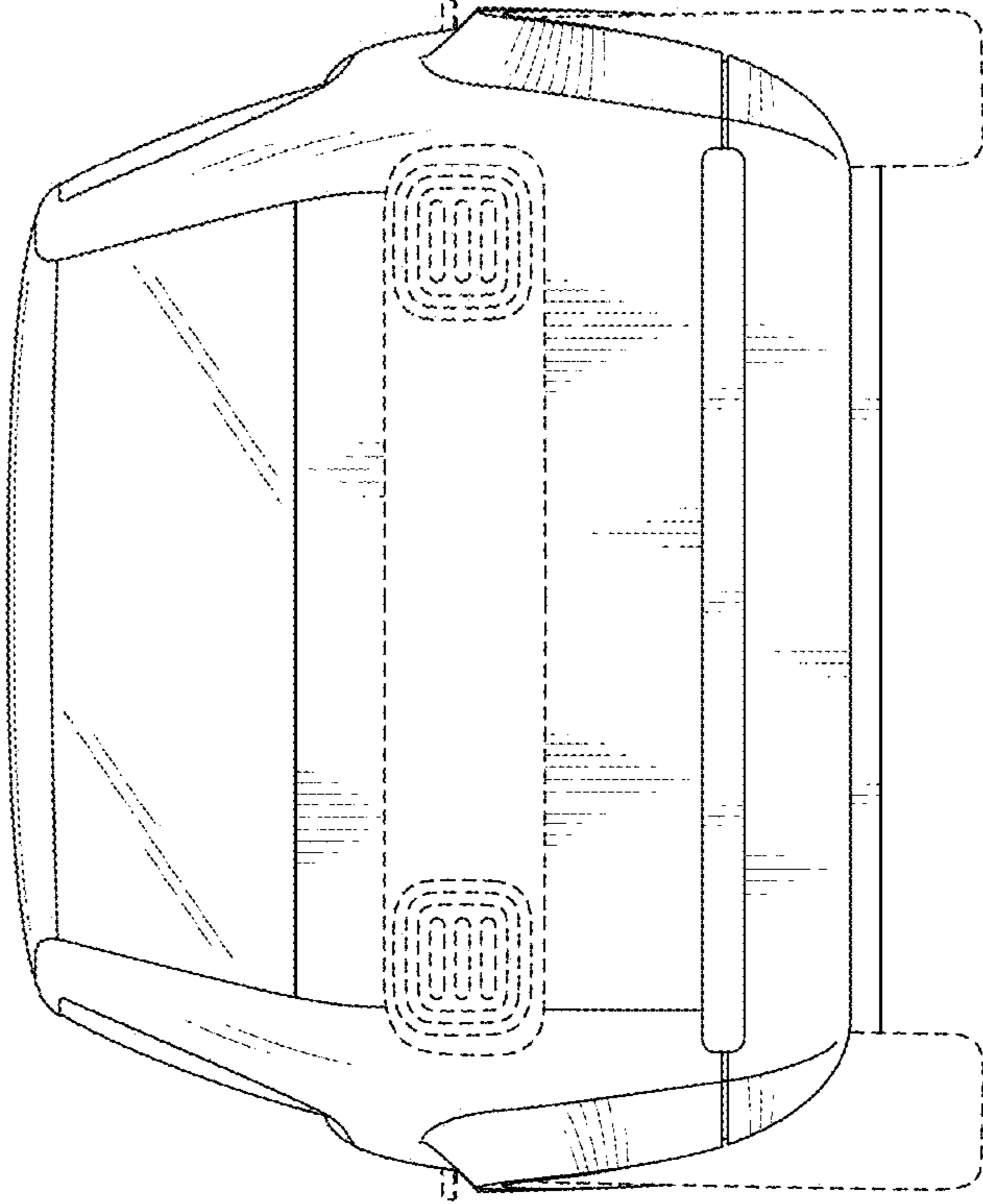

FIG. 6

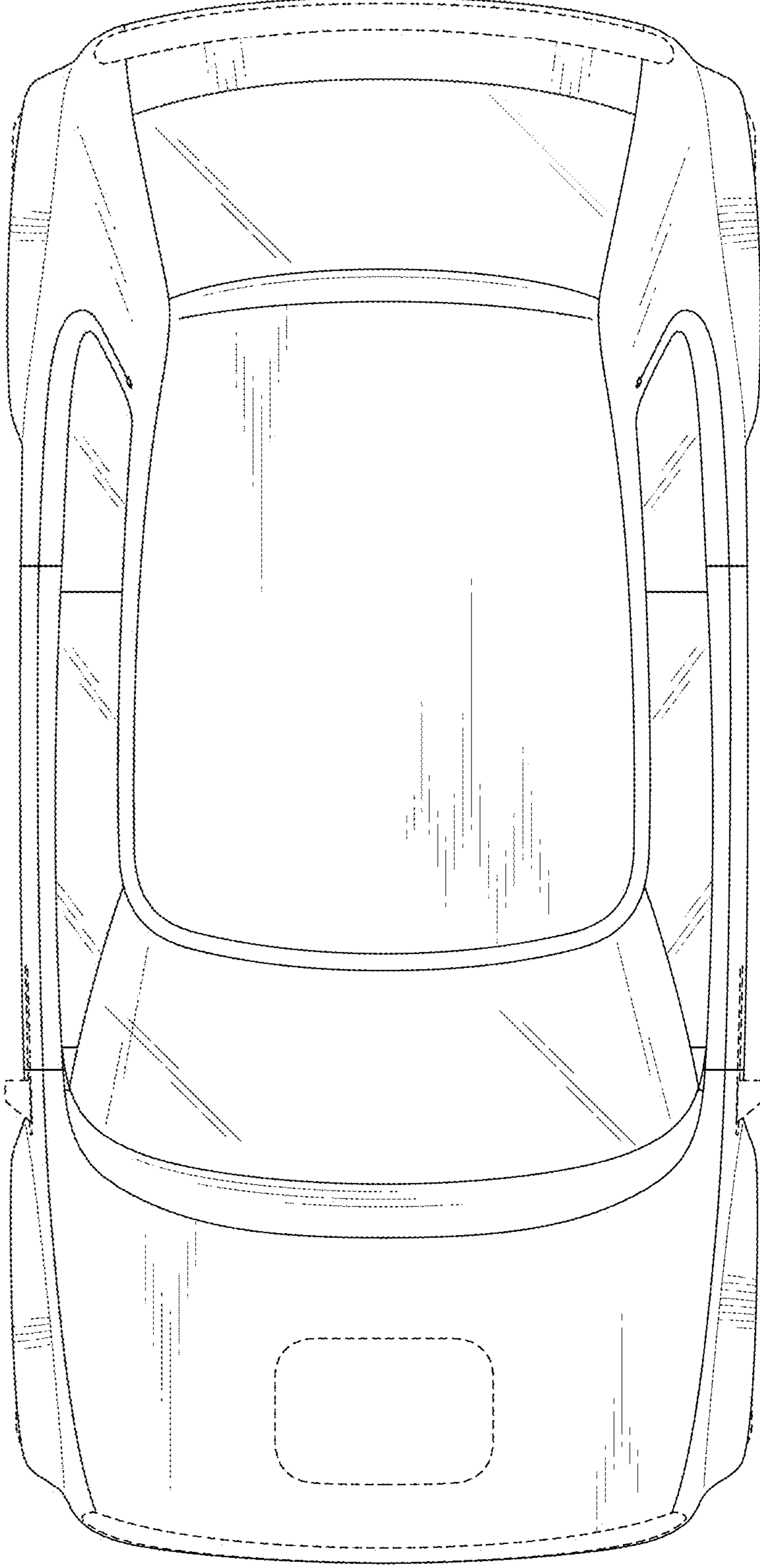

FIG. 7