



US00D864877S

(12) **United States Design Patent**  
**Danesh et al.**

(10) **Patent No.:** **US D864,877 S**  
(45) **Date of Patent:** **\*\* Oct. 29, 2019**

(54) **PLASTIC DEEP ELECTRICAL JUNCTION BOX WITH A LIGHTING MODULE MOUNTING YOKE**

FOREIGN PATENT DOCUMENTS

CA 2243934 C 6/2002  
CA 2502637 A1 9/2005

(Continued)

(71) Applicant: **DMF, Inc.**, Carson, CA (US)

OTHER PUBLICATIONS

(72) Inventors: **Michael D. Danesh**, Carson, CA (US);  
**Amir Lotfi**, Redondo Beach, CA (US);  
**Ali A. Nikooyan**, Santa Ana, CA (US)

“Advanced LED Solutions,” *Imtra Marine Lighting*, 2011. 39 pages.  
(Continued)

(73) Assignee: **DMF, INC.**, Carson, CA (US)

*Primary Examiner* — Rhea Shields

(\*\*) Term: **15 Years**

(74) *Attorney, Agent, or Firm* — Smith Baluch LLP

(21) Appl. No.: **29/678,478**

(57) **CLAIM**

(22) Filed: **Jan. 29, 2019**

The ornamental design for a combined plastic deep electrical junction box with a lighting module mounting yoke, as shown and described.

(51) **LOC (12) Cl.** ..... **13-03**

**DESCRIPTION**

(52) **U.S. Cl.**

USPC ..... **D13/152**

(58) **Field of Classification Search**

USPC ..... D13/152, 155, 133, 156, 158, 184;  
D15/89; 174/659, 58, 483; D7/396.2;  
D23/261

CPC ..... H02G 3/185; H02G 3/125; H02G 3/0625;  
H02G 3/083; H02G 3/20; H02G 3/126;  
H02G 3/12; H02G 3/14

See application file for complete search history.

FIG. 1 is a top view of a combined plastic deep electrical junction box with a lighting module mounting yoke removed and showing our new design;  
FIG. 2 is a bottom view thereof;  
FIG. 3 is a right side view thereof, the left side being identical;  
FIG. 4 is a front view thereof, the rear view being identical;  
FIG. 5 is a top perspective view thereof; and  
FIG. 6 is a bottom perspective view thereof.  
FIG. 7 is a bottom perspective view of a combined plastic deep electrical junction box with a lighting module mounting yoke shown in an alternate lowered position.  
FIG. 8 is a bottom perspective view of a combined plastic deep electrical junction box with a lighting module mounting yoke shown in an alternate raised position; and  
FIG. 9 is a bottom view thereof.

(56) **References Cited**

U.S. PATENT DOCUMENTS

1,471,340 A 10/1923 Knight  
2,038,784 A 4/1936 Ghadiali  
2,197,737 A 4/1940 Appleton  
2,528,989 A 11/1950 Ammells  
2,642,246 A 6/1953 Larry  
D180,844 S 8/1957 Poliakoff  
3,023,920 A 3/1962 Cook et al.

(Continued)

FIG. 10 is a bottom view of the lighting module mounting yoke with the plastic deep electrical junction box removed and showing our new design;  
FIG. 11 is a top view thereof; and  
FIG. 12 is a top perspective view thereof.

**1 Claim, 12 Drawing Sheets**

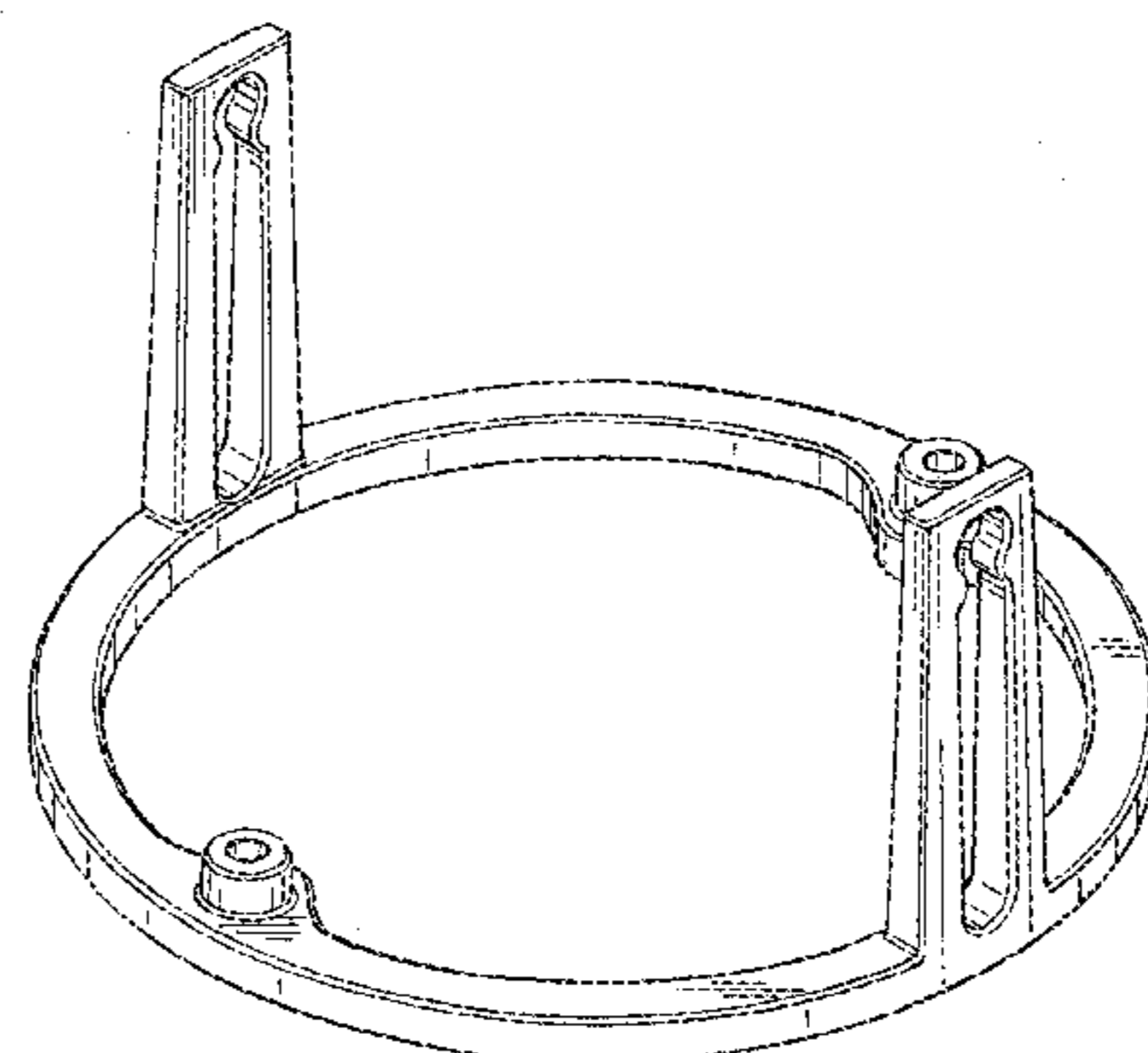
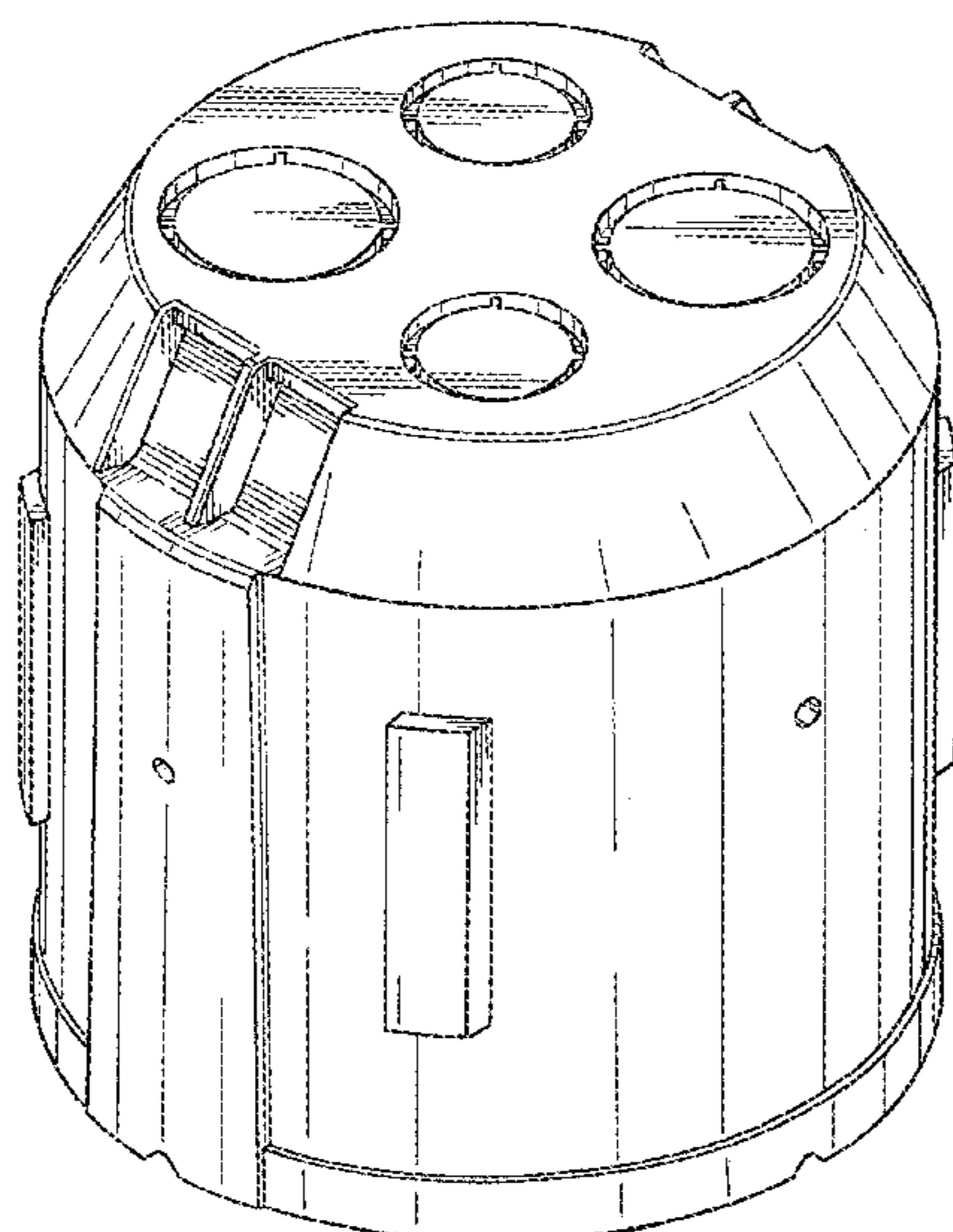

US D864,877 S

(56)

References Cited

U.S. PATENT DOCUMENTS

3,422,261 A 1/1969 McGinty  
3,460,299 A 8/1969 Wilson  
3,650,046 A 3/1972 Skinner  
3,711,053 A 1/1973 Drake  
D227,989 S \* 7/1973 Geisel ..... D13/156  
3,812,342 A 5/1974 Mcnamara  
D245,905 S 9/1977 Taylor  
4,088,827 A 5/1978 Kohaut  
4,154,218 A 5/1979 Hulet  
4,154,219 A 5/1979 Gupta et al.  
4,176,758 A \* 12/1979 Glick ..... H02G 3/125  
174/58  
4,280,169 A 7/1981 Allen  
4,399,497 A 8/1983 Druffel  
4,520,435 A 5/1985 Baldwin  
4,601,145 A 7/1986 Wilcox  
4,723,747 A 2/1988 Karp et al.  
4,729,080 A 3/1988 Fremont et al.  
4,754,377 A 6/1988 Wenman  
4,930,054 A 5/1990 Krebs  
5,216,203 A 6/1993 Gower  
5,239,132 A 8/1993 Bartow  
5,250,269 A 10/1993 Langer et al.  
5,266,050 A \* 11/1993 O'Neil ..... H02G 3/0625  
174/659  
5,382,752 A 1/1995 Reyhan et al.  
5,465,199 A 11/1995 Bray et al.  
5,505,419 A 4/1996 Gabrius  
5,544,870 A 8/1996 Kelly et al.  
5,562,343 A 10/1996 Chan et al.  
5,571,993 A 11/1996 Jones et al.  
5,580,158 A 12/1996 Aubrey et al.  
5,588,737 A 12/1996 Kusmer  
5,603,424 A 2/1997 Bordwell et al.  
5,613,338 A 3/1997 Esposito  
D381,111 S 7/1997 Lecluze  
5,662,413 A 9/1997 Akiyama et al.  
D386,277 S 11/1997 Lecluze  
D387,466 S 12/1997 Lecluze  
5,738,436 A 4/1998 Cummings et al.  
5,836,678 A 11/1998 Wright et al.  
5,942,726 A 8/1999 Reiker  
5,944,412 A 9/1999 Janos et al.  
5,957,573 A 9/1999 Wedekind et al.  
5,975,323 A 11/1999 Turan  
6,082,878 A 7/2000 Doubek et al.  
6,105,334 A 8/2000 Monson et al.  
6,161,910 A 12/2000 Reisenauer et al.  
6,170,685 B1 1/2001 Currier  
6,170,965 B1 1/2001 Kotovsky  
6,174,076 B1 1/2001 Petrakis et al.  
6,176,599 B1 1/2001 Farzen  
6,267,491 B1 7/2001 Parrigin  
6,332,597 B1 12/2001 Korcz et al.  
6,350,043 B1 2/2002 Gloisten  
6,364,511 B1 4/2002 Cohen  
6,402,112 B1 6/2002 Thomas et al.  
D461,455 S 8/2002 Forbes  
6,461,016 B1 10/2002 Jamison et al.  
6,474,846 B1 11/2002 Kelmelis et al.  
6,491,413 B1 12/2002 Benesohn  
D468,697 S 1/2003 Straub, Jr.  
6,515,313 B1 2/2003 Ibbetson et al.  
6,583,573 B2 6/2003 Bierman  
6,585,389 B2 7/2003 Bonazzi  
6,600,175 B1 7/2003 Baretz et al.  
D478,872 S \* 8/2003 Heggem ..... D13/152  
6,657,236 B1 12/2003 Thibeault et al.  
6,666,419 B1 12/2003 Vrame  
D487,600 S 3/2004 Fickas  
D488,583 S 4/2004 Benghozi  
6,719,438 B2 4/2004 Seveck et al.  
6,758,578 B1 7/2004 Chou  
6,777,615 B1 8/2004 Gretz

6,827,229 B2 \* 12/2004 Dinh ..... H02G 3/20  
220/3.3  
6,906,352 B2 6/2005 Edmond et al.  
D509,314 S 9/2005 Rashidi  
6,948,829 B2 9/2005 Verdes et al.  
6,958,497 B2 10/2005 Emerson et al.  
6,964,501 B2 11/2005 Ryan  
D516,235 S 2/2006 Rashidi  
7,064,269 B2 6/2006 Smith  
D528,673 S 9/2006 Maxik et al.  
D531,740 S 11/2006 Maxik  
D532,532 S 11/2006 Maxik  
7,148,420 B1 \* 12/2006 Johnson ..... H02G 3/125  
174/58  
7,154,040 B1 12/2006 Tompkins  
7,170,015 B1 \* 1/2007 Roesch ..... H02G 3/126  
174/480  
D536,349 S \* 2/2007 Humber ..... D15/89  
D537,039 S 2/2007 Pincek  
D539,229 S \* 3/2007 Murphey ..... D13/155  
7,186,008 B2 3/2007 Patti  
7,190,126 B1 3/2007 Paton  
7,211,833 B2 5/2007 Slater, Jr. et al.  
7,213,940 B1 5/2007 Van De Ven et al.  
D547,889 S 7/2007 Huang  
D552,969 S 10/2007 Bobrowski et al.  
D553,267 S 10/2007 Yuen  
D555,106 S \* 11/2007 Pape ..... D13/158  
D556,144 S \* 11/2007 Dinh ..... D13/152  
7,297,870 B1 11/2007 Sartini  
7,312,474 B2 12/2007 Emerson et al.  
7,320,536 B2 1/2008 Petrakis et al.  
D561,372 S 2/2008 Yan  
D561,373 S 2/2008 Yan  
7,335,920 B2 2/2008 Denbaars et al.  
D563,896 S 3/2008 Greenslate  
7,347,580 B2 3/2008 Blackman et al.  
D570,012 S 5/2008 Huang  
7,374,308 B2 5/2008 Seveck et al.  
D570,504 S 6/2008 Maxik et al.  
D570,505 S 6/2008 Maxik et al.  
7,399,104 B2 7/2008 Rappaport  
D578,677 S 10/2008 Huang  
7,431,482 B1 10/2008 Morgan et al.  
7,432,440 B2 10/2008 Hull et al.  
7,442,883 B2 \* 10/2008 Jolly ..... H02G 3/185  
174/483  
7,446,345 B2 11/2008 Emerson et al.  
7,473,005 B2 1/2009 O'Brien  
7,488,097 B2 2/2009 Reisenauer et al.  
7,494,258 B2 2/2009 McNaught  
7,503,145 B2 3/2009 Newbold et al.  
7,524,089 B2 4/2009 Park  
D591,894 S 5/2009 Flank  
7,534,989 B2 5/2009 Suehara et al.  
D596,154 S \* 7/2009 Rivkin ..... D13/184  
7,566,154 B2 7/2009 Gloisten et al.  
D599,040 S 8/2009 Alexander et al.  
D600,836 S 9/2009 Hanley et al.  
7,588,359 B2 9/2009 Coushaine et al.  
7,592,583 B2 9/2009 Page et al.  
D606,696 S 12/2009 Chen et al.  
7,625,105 B1 12/2009 Johnson  
7,628,513 B2 12/2009 Chiu  
7,651,238 B2 1/2010 O'Brien  
7,654,705 B2 2/2010 Czech et al.  
D611,650 S 3/2010 Broekhoff  
7,670,021 B2 3/2010 Chou  
7,673,841 B2 3/2010 Wronski  
7,677,766 B2 3/2010 Boyer  
7,692,182 B2 4/2010 Bergmann et al.  
7,704,763 B2 4/2010 Fujii et al.  
D616,118 S 5/2010 Thomas et al.  
7,722,208 B1 5/2010 Dupre et al.  
7,722,227 B2 5/2010 Zhang et al.  
7,735,795 B2 6/2010 Wronski  
7,735,798 B2 6/2010 Kojima  
7,748,887 B2 7/2010 Zampini, II et al.  
7,766,518 B2 8/2010 Piegras et al.



(56)

References Cited

U.S. PATENT DOCUMENTS

7,769,192 B2	8/2010	Takagi et al.	D682,459 S	5/2013	Gordin et al.
7,771,082 B2	8/2010	Peng	D683,063 S	5/2013	Lopez et al.
7,771,094 B2	8/2010	Goode	D683,890 S	6/2013	Lopez et al.
D624,692 S	9/2010	Mackin et al.	D684,269 S	6/2013	Wang et al.
D625,847 S	10/2010	Maglica	D684,719 S	6/2013	Rashidi
D625,876 S	10/2010	Chen et al.	D685,118 S	6/2013	Rashidi
D627,727 S	11/2010	Alexander et al.	D685,120 S	6/2013	Rashidi
7,828,465 B2	11/2010	Roberge et al.	8,454,204 B1	6/2013	Chang et al.
D629,366 S *	12/2010	Ericson ..... D13/156	D685,507 S	7/2013	Sun
7,871,184 B2	1/2011	Peng	D687,586 S	8/2013	Rashidi
7,874,539 B2	1/2011	Wright et al.	D687,587 S	8/2013	Rashidi
7,874,709 B1	1/2011	Beadle	D687,588 S	8/2013	Rashidi
D633,224 S	2/2011	Lee	D687,980 S	8/2013	Gravely et al.
D636,903 S	4/2011	Torenbeek	D688,405 S	8/2013	Kim et al.
D637,339 S	5/2011	Hasan et al.	D690,049 S	9/2013	Rashidi
D637,340 S	5/2011	Hasan et al.	D690,864 S	10/2013	Rashidi
7,950,832 B2	5/2011	Tanaka et al.	D690,865 S	10/2013	Rashidi
D639,499 S	6/2011	Choi et al.	D690,866 S	10/2013	Rashidi
D640,819 S	6/2011	Pan	D691,314 S	10/2013	Rashidi
7,959,332 B2	6/2011	Tickner et al.	D691,315 S	10/2013	Samson
7,967,480 B2	6/2011	Pickard et al.	D691,763 S	10/2013	Hand et al.
D642,317 S	7/2011	Rashidi	8,550,669 B2	10/2013	Macwan et al.
7,972,035 B2	7/2011	Boyer	D693,043 S	11/2013	Schmalfluss et al.
7,972,043 B2	7/2011	Schutte	D693,517 S	11/2013	Davis
D642,536 S *	8/2011	Robinson ..... D13/154	D694,456 S	11/2013	Rowlette, Jr. et al.
D643,970 S	8/2011	Kim et al.	D695,441 S	12/2013	Lui et al.
D646,011 S	9/2011	Rashidi	D696,446 S	12/2013	Huh
8,013,243 B2 *	9/2011	Korcz ..... H02G 3/126 174/481	D696,447 S	12/2013	Huh
8,038,113 B2	10/2011	Fryzek et al.	D696,448 S	12/2013	Huh
D648,476 S	11/2011	Choi et al.	8,602,601 B2	12/2013	Khazi et al.
D648,477 S	11/2011	Kim et al.	D698,067 S	1/2014	Rashidi
D650,115 S	12/2011	Kim et al.	D698,068 S	1/2014	Rashidi
8,070,328 B1	12/2011	Knoble et al.	8,622,361 B2	1/2014	Wronski
8,096,670 B2	1/2012	Trott	D698,985 S	2/2014	Lopez et al.
D654,205 S	2/2012	Rashidi	D699,384 S	2/2014	Rashidi
D656,263 S	3/2012	Ogawa et al.	D699,687 S *	2/2014	Baldwin ..... D13/156
8,142,057 B2	3/2012	Roos et al.	D700,387 S	2/2014	Snell
8,152,334 B2	4/2012	Krogman	8,641,243 B1	2/2014	Rashidi
D658,788 S	5/2012	Dudik et al.	8,659,034 B2	2/2014	Baretz et al.
D658,802 S	5/2012	Chen	D701,175 S *	3/2014	Baldwin ..... D13/156
D659,862 S	5/2012	Tsai	D701,466 S	3/2014	Clifford et al.
D659,879 S	5/2012	Rashidi	8,672,518 B2	3/2014	Boomgaarden et al.
D660,814 S	5/2012	Wilson	D702,867 S	4/2014	Kim et al.
8,182,116 B2	5/2012	Zhang et al.	D703,843 S	4/2014	Cheng
8,201,968 B2	6/2012	Maxik et al.	8,684,569 B2	4/2014	Pickard et al.
D663,058 S	7/2012	Pan	D705,472 S	5/2014	Huh
D663,466 S	7/2012	Rashidi	8,727,582 B2	5/2014	Brown et al.
D664,274 S	7/2012	de Visser et al.	D708,381 S	7/2014	Rashidi
D664,705 S	7/2012	Kong et al.	8,777,449 B2	7/2014	Ven et al.
8,215,805 B2	7/2012	Cogliano et al.	D710,529 S	8/2014	Lopez et al.
8,220,970 B1	7/2012	Khazi et al.	8,801,217 B2	8/2014	Oehle et al.
8,226,270 B2	7/2012	Yamamoto et al.	8,820,985 B1	9/2014	Tam et al.
8,238,050 B2	8/2012	Minano et al.	8,833,013 B2	9/2014	Harman
8,240,630 B2	8/2012	Wronski	D714,989 S	10/2014	Rowlette, Jr. et al.
D667,155 S	9/2012	Rashidi	8,870,426 B2	10/2014	Biebl et al.
8,262,255 B1	9/2012	Rashidi	8,888,332 B2	11/2014	Martis et al.
D668,372 S	10/2012	Renshaw et al.	8,890,414 B2	11/2014	Rowlette, Jr. et al.
D668,809 S	10/2012	Rashidi	D721,845 S	1/2015	Lui et al.
D669,198 S	10/2012	Qui	8,939,418 B2	1/2015	Green et al.
D669,199 S	10/2012	Chuang	D722,296 S *	2/2015	Taylor ..... D13/152
D669,620 S	10/2012	Rashidi	D722,977 S	2/2015	Hagarty
8,277,090 B2	10/2012	Fryzek et al.	D722,978 S	2/2015	Hagarty
8,308,322 B2	11/2012	Santiago et al.	8,950,898 B2	2/2015	Catalano
D673,869 S	1/2013	Yu	D726,363 S	4/2015	Danesh
D676,263 S	2/2013	Birke	D726,949 S	4/2015	Redfern
D676,814 S	2/2013	Paul	9,004,435 B2	4/2015	Wronski
8,376,593 B2	2/2013	Bazydola et al.	9,039,254 B2	5/2015	Danesh
D677,417 S	3/2013	Rashidi	D731,689 S	6/2015	Bernard et al.
D677,634 S *	3/2013	Korcz ..... D13/152	9,062,866 B1	6/2015	Christ et al.
D679,047 S	3/2013	Tickner et al.	9,065,264 B2	6/2015	Cooper et al.
8,403,533 B1	3/2013	Paulsel	9,068,719 B2	6/2015	Van De Ven et al.
8,403,541 B1	3/2013	Rashidi	D734,525 S	7/2015	Gordin et al.
D681,259 S	4/2013	Kong	D735,012 S	7/2015	Cowie
8,408,759 B1	4/2013	Rashidi	D735,142 S	7/2015	Hagarty
			9,078,299 B2	7/2015	Ashdown
			9,109,760 B2	8/2015	Shum et al.
			D739,590 S	9/2015	Redfern
			9,140,441 B2	9/2015	Goelz et al.
			D742,325 S	10/2015	Leung



(56)

References Cited

U.S. PATENT DOCUMENTS

9,151,457 B2	10/2015	Pickard et al.	2003/0006353 A1	1/2003	Dinh et al.
9,151,477 B2	10/2015	Pickard et al.	2003/0016532 A1	1/2003	Reed
9,217,560 B2	12/2015	Harbers et al.	2003/0021104 A1	1/2003	Tsao
9,222,661 B2	12/2015	Kim et al.	2003/0161153 A1	8/2003	Patti
9,239,131 B1	1/2016	Wronski et al.	2004/0001337 A1	1/2004	Defouw et al.
9,285,103 B2	3/2016	Van De Ven et al.	2004/0156199 A1	8/2004	Rivas et al.
9,291,319 B2	3/2016	Kathawate et al.	2005/0225966 A1	10/2005	Hartmann et al.
9,301,362 B2	3/2016	Dohn et al.	2005/0227536 A1	10/2005	Gamache et al.
D754,078 S *	4/2016	Baldwin ..... D13/156	2005/0231962 A1	10/2005	Koba et al.
D754,079 S *	4/2016	Baldwin ..... D13/156	2005/0237746 A1	10/2005	Yiu
D754,605 S *	4/2016	McMillan ..... D13/133	2006/0005988 A1 *	1/2006	Jorgensen ..... H02G 3/083 174/655
9,303,812 B2	4/2016	Green et al.	2006/0158873 A1	7/2006	Newbold et al.
9,310,038 B2	4/2016	Athalye	2006/0198126 A1	9/2006	Jones
9,310,052 B1	4/2016	Shum	2006/0215408 A1	9/2006	Lee
9,322,543 B2	4/2016	Hussell et al.	2006/0237601 A1	10/2006	Rinderer
D756,025 S	5/2016	Wronski et al.	2006/0243877 A1	11/2006	Rippel
9,347,655 B2	5/2016	Boomgaarden et al.	2006/0250788 A1	11/2006	Hodge et al.
9,360,190 B1	6/2016	Shum et al.	2007/0035951 A1	2/2007	Tseng
9,366,418 B2	6/2016	Gifford	2007/0185675 A1	8/2007	Papamichael et al.
9,371,966 B2	6/2016	Rowlette, Jr. et al.	2007/0200039 A1	8/2007	Petak
D762,181 S	7/2016	Lin	2007/0206374 A1	9/2007	Petrakis et al.
9,395,051 B2	7/2016	Hussell et al.	2008/0002414 A1	1/2008	Miletich et al.
D762,906 S	8/2016	Jeswani et al.	2008/0019138 A1	1/2008	Otte et al.
D764,079 S	8/2016	Wu	2008/0112168 A1	5/2008	Pickard et al.
9,417,506 B1	8/2016	Tirosh	2008/0112170 A1	5/2008	Trott
D766,185 S	9/2016	Hagarty	2008/0112171 A1	5/2008	Patti et al.
D767,199 S	9/2016	Wronski et al.	2008/0137347 A1	6/2008	Trott et al.
9,447,917 B1	9/2016	Wronski et al.	2008/0165545 A1	7/2008	O'Brien
D768,325 S	10/2016	Xu	2008/0232116 A1	9/2008	Kim
D768,326 S	10/2016	Guzzini	2008/0247181 A1	10/2008	Dixon
D769,501 S	10/2016	Jeswani et al.	2009/0003009 A1	1/2009	Tessnow et al.
D770,065 S	10/2016	Tittle	2009/0034261 A1	2/2009	Grove
9,476,552 B2	10/2016	Myers et al.	2009/0080189 A1	3/2009	Wegner
9,488,324 B2	11/2016	Shum et al.	2009/0086484 A1	4/2009	Johnson
D776,324 S	1/2017	Gierl et al.	2009/0135613 A1	5/2009	Peng
D777,967 S	1/2017	Redfern	2009/0141500 A1	6/2009	Peng
9,534,751 B2	1/2017	Maglica et al.	2009/0141506 A1	6/2009	Lan et al.
D778,241 S	2/2017	Holbrook et al.	2009/0141508 A1	6/2009	Peng
D778,484 S	2/2017	Guzzini	2009/0147517 A1	6/2009	Li
D779,100 S	2/2017	Redfern	2009/0161356 A1	6/2009	Negley et al.
9,581,302 B2	2/2017	Danesh	2009/0237924 A1	9/2009	Ladewig
9,599,315 B1	3/2017	Harpenau et al.	2009/0280695 A1	11/2009	Sekela et al.
9,605,910 B2	3/2017	Swedberg et al.	2009/0283292 A1 *	11/2009	Lehr ..... H02G 3/14 174/67
D785,228 S	4/2017	Guzzini	2009/0290343 A1	11/2009	Brown et al.
D786,472 S	5/2017	Redfern	2010/0014282 A1	1/2010	Danesh
D786,474 S	5/2017	Fujisawa	2010/0061108 A1	3/2010	Zhang et al.
D788,330 S	5/2017	Johnson et al.	2010/0110690 A1	5/2010	Hsu et al.
D790,102 S	6/2017	Guzzini	2010/0110698 A1	5/2010	Harwood et al.
9,673,597 B2	6/2017	Lee	2010/0148673 A1	6/2010	Stewart et al.
9,689,541 B2	6/2017	Wronski	2010/0149822 A1	6/2010	Cogliano et al.
D791,709 S *	7/2017	Holton ..... D13/152	2010/0165643 A1	7/2010	Russo et al.
D791,711 S *	7/2017	Holton ..... D13/152	2010/0244709 A1	9/2010	Steiner et al.
D791,712 S *	7/2017	Holton ..... D13/152	2010/0246172 A1	9/2010	Liu
9,696,021 B2	7/2017	Wronski	2010/0259919 A1	10/2010	Khazi et al.
9,702,516 B1	7/2017	Vasquez et al.	2010/0270903 A1	10/2010	Jao et al.
D795,820 S *	8/2017	Wengreen ..... D13/155	2010/0284185 A1	11/2010	Ngai
9,732,904 B1	8/2017	Wronski	2010/0302778 A1	12/2010	Dabiet et al.
9,739,464 B2	8/2017	Wronski	2011/0043040 A1	2/2011	Porter et al.
9,791,111 B1	10/2017	Huang et al.	2011/0063831 A1	3/2011	Cook
9,803,839 B2	10/2017	Visser et al.	2011/0068687 A1	3/2011	Takahasi et al.
D805,660 S	12/2017	Creasman et al.	2011/0069499 A1	3/2011	Trott et al.
D809,176 S	1/2018	Partington	2011/0080750 A1	4/2011	Jones et al.
9,863,619 B2	1/2018	Mak	2011/0116276 A1	5/2011	Okamura et al.
D809,465 S *	2/2018	Keirstead ..... D13/152	2011/0121756 A1	5/2011	Thomas et al.
9,964,266 B2	5/2018	Danesh	2011/0134634 A1	6/2011	Gingrich, III et al.
D820,494 S	6/2018	Cohen	2011/0134651 A1	6/2011	Berman
9,995,441 B2	6/2018	Power et al.	2011/0140633 A1	6/2011	Archenhold
D824,494 S *	7/2018	Martins ..... D23/261	2011/0170294 A1	7/2011	Mier-Langner et al.
D832,218 S *	10/2018	Wronski ..... D13/152	2011/0194299 A1	8/2011	Crooks et al.
D833,977 S	11/2018	Danesh et al.	2011/0216534 A1	9/2011	Tickner et al.
10,139,059 B2	11/2018	Danesh	2011/0226919 A1	9/2011	Fryzek et al.
D836,976 S *	1/2019	Reese ..... D7/396.2	2011/0241557 A1	10/2011	Grotkowski et al.
D848,375 S	5/2019	Danesh et al.	2011/0255292 A1	10/2011	Shen
D851,046 S	6/2019	Peng et al.	2011/0267828 A1	11/2011	Bazydola et al.
2002/0172047 A1	11/2002	Ashley	2011/0285314 A1	11/2011	Carney et al.
			2012/0020104 A1	1/2012	Biebl et al.
			2012/0074852 A1	3/2012	Delnoij



(56)

References Cited

U.S. PATENT DOCUMENTS

2012/0106176 A1 5/2012 Lopez et al.  
 2012/0113642 A1 5/2012 Catalano  
 2012/0140442 A1 6/2012 Woo et al.  
 2012/0162994 A1 6/2012 Wasniewski et al.  
 2012/0182744 A1 7/2012 Santiago et al.  
 2012/0188762 A1 7/2012 Joung et al.  
 2012/0243237 A1 9/2012 Toda et al.  
 2012/0287625 A1 11/2012 Macwan et al.  
 2012/0305868 A1\* 12/2012 Callahan ..... H02G 3/12  
 254/134.3 R  
 2013/0009552 A1 1/2013 Page  
 2013/0010476 A1 1/2013 Pickard et al.  
 2013/0016864 A1 1/2013 Ivey et al.  
 2013/0033872 A1 2/2013 Randolph et al.  
 2013/0051012 A1 2/2013 Oehle et al.  
 2013/0141913 A1 6/2013 Sachsenweger  
 2013/0155681 A1 6/2013 Nall et al.  
 2013/0163254 A1 6/2013 Chang et al.  
 2013/0170232 A1 7/2013 Park et al.  
 2013/0170233 A1 7/2013 Nezu et al.  
 2013/0258677 A1 10/2013 Fryzek et al.  
 2013/0265750 A1 10/2013 Pickard et al.  
 2013/0271989 A1 10/2013 Hussell et al.  
 2013/0294084 A1 11/2013 Kathawate et al.  
 2013/0301252 A1 11/2013 Hussell et al.  
 2013/0322062 A1 12/2013 Danesh  
 2013/0322084 A1 12/2013 Ebisawa  
 2013/0335980 A1 12/2013 Nakasuji et al.  
 2014/0036497 A1 2/2014 Hussell et al.  
 2014/0049957 A1 2/2014 Goelz et al.  
 2014/0063776 A1 3/2014 Clark et al.  
 2014/0071679 A1 3/2014 Booth  
 2014/0071687 A1 3/2014 Tickner et al.  
 2014/0140490 A1 5/2014 Roberts et al.  
 2014/0063818 A1 6/2014 Randolph et al.  
 2014/0159616 A1 6/2014 Wang et al.  
 2014/0233246 A1 8/2014 Lafreniere et al.  
 2014/0254177 A1 9/2014 Danesh  
 2014/0265933 A1 9/2014 Melanson et al.  
 2014/0268836 A1 9/2014 Thompson  
 2014/0299730 A1 10/2014 Green et al.  
 2014/0313775 A1 10/2014 Myers et al.  
 2014/0321122 A1 10/2014 Domagala et al.  
 2014/0347848 A1 11/2014 Pisavadia et al.  
 2015/0009676 A1 1/2015 Danesh  
 2015/0029732 A1 1/2015 Hatch  
 2015/0078008 A1 3/2015 He  
 2015/0138779 A1 5/2015 Livesay et al.  
 2015/0184837 A1 7/2015 Zhang et al.  
 2015/0198324 A1 7/2015 O'Brien et al.  
 2015/0219317 A1 8/2015 Gatof et al.  
 2015/0233556 A1 8/2015 Danesh  
 2015/0241039 A1 8/2015 Fryzek  
 2015/0263497 A1 9/2015 Korcz et al.  
 2015/0276185 A1 10/2015 Bailey et al.  
 2015/0308662 A1 10/2015 Vice et al.  
 2015/0345761 A1 12/2015 Lawlor  
 2015/0362159 A1 12/2015 Ludyjan  
 2016/0126860 A1 5/2016 Summerland  
 2016/0209007 A1 7/2016 Belmonte et al.  
 2016/0218626 A1 7/2016 Del Carmen  
 2016/0308342 A1 10/2016 Witherbee et al.  
 2016/0312987 A1 10/2016 Danesh  
 2016/0348860 A1 12/2016 Danesh  
 2016/0348861 A1 12/2016 Bailey et al.  
 2016/0366738 A1 12/2016 Boulanger et al.  
 2017/0005460 A1 1/2017 Lee  
 2017/0045213 A1 2/2017 Williams et al.  
 2017/0059135 A1 3/2017 Jones  
 2017/0138576 A1 5/2017 Peng et al.  
 2017/0138581 A1 5/2017 Doust  
 2017/0198896 A1 7/2017 May  
 2017/0307188 A1 10/2017 Oudina et al.  
 2018/0231197 A1 8/2018 Danesh  
 2018/0372284 A1 12/2018 Danesh et al.

2019/0049080 A1 2/2019 Danesh  
 2019/0063701 A1 2/2019 Lotfi et al.  
 2019/0093836 A1 3/2019 Danesh

FOREIGN PATENT DOCUMENTS

CA 2691480 C 4/2012  
 CA 2734369 A1 10/2013  
 CA 2561459 A1 11/2013  
 CA 2815067 11/2013  
 CA 2848289 A1 10/2014  
 CN 2182475 Y 11/1994  
 CN 201059503 Y 5/2008  
 CN 201259125 Y 6/2009  
 CN 101608781 A 12/2009  
 CN 201636626 U 11/2010  
 CN 102062373 A 5/2011  
 CN 202014067 U 10/2011  
 CN 202392473 U 8/2012  
 CN 202733693 U 2/2013  
 CN 103307518 A 9/2013  
 CN 103322476 A 9/2013  
 CN 203215483 U 9/2013  
 CN 101498411 B 11/2013  
 CN 203273663 U 11/2013  
 CN 203297980 U 11/2013  
 CN 203628464 U 12/2013  
 CN 203641919 U 6/2014  
 CN 204300818 U 4/2015  
 CN 104654142 A 5/2015  
 CN 204513161 U 7/2015  
 CN 204611541 U 9/2015  
 CN 204786225 U 11/2015  
 CN 204829578 U 12/2015  
 CN 103712135 B 4/2016  
 CN 205606362 U 9/2016  
 CN 206130742 U 4/2017  
 CN 103154606 B 5/2017  
 CN 206222112 U 6/2017  
 CN 107013845 A 8/2017  
 CN 107084343 A 8/2017  
 DE 9109828 U1 2/1992  
 DE 199 47 208 5/2001  
 EP 1 672 155 A1 6/2006  
 EP 2 095 938 A1 2/2008  
 EP 2 306 072 A1 4/2011  
 EP 2 453 169 A2 5/2012  
 EP 2 193 309 B1 7/2012  
 EP 2 735 787 A1 5/2014  
 EP 3 104 024 A1 12/2016  
 GB 2427020 A 12/2006  
 GB 2509772 A 7/2014  
 JP H02113002 U 9/1990  
 JP 2007091052 A 4/2007  
 JP 2007265961 A 10/2007  
 JP 2011060450 A2 3/2011  
 JP 2012064551 A2 3/2012  
 JP 2015002027 A2 1/2015  
 JP 2015002028 A2 1/2015  
 JP 2017107699 A2 6/2017  
 KR 1020110008796 A 1/2011  
 KR 1020120061625 A 6/2012  
 MX 2011002947 A 9/2011  
 TW 474382 U 1/2002  
 WO WO 2013/128896 A1 9/2013  
 WO WO 2015/000212 A1 1/2015  
 WO WO 2016152166 A2 9/2016

OTHER PUBLICATIONS

“Cree LMH2 LED Module with TrueWhite Technology,” Cree Product Family Data Sheet. 2011. 3 pages.  
 “Cree LMH2 LED Modules Design Guide,” Cree Product Design Guide. 2011. 20 pages.  
 “Cree LMH2 LED Modules,” Mouser Electronics. 2 pages.  
 “LED Undercabinet Pocket Guide,” ELCO Lighting. 12 pages.



(56)

## References Cited

## OTHER PUBLICATIONS

- “Membrane Penetrations in Fire-Resistance Rated Walls,” [https://www.ul.com/wp-content/uploads/2014/04/ul\\_MembranePenetrations.pdf](https://www.ul.com/wp-content/uploads/2014/04/ul_MembranePenetrations.pdf), Issue 1, 2009, 2 pages.
- “Metallic and Non-metallic Outlet Boxes Used in Fire-rated Assembly,” <https://iaeimagazine.org/magazine/2000/09/16/metallic-and-non-metallic-outlet-boxes-used-in-fire-rated-assembly/>, Sep. 16, 2000, 5 pages.
- “Metallic Outlet Boxes,” UL 514A, Underwriters Laboratories, Inc., Feb. 16, 2004 (Title Page Reprinted Aug. 10, 2007), 106 pages.
- “Outlet Boxes for Use in Fire Rated Assemblies,” [https://www.ul.com/wp-content/uploads/2014/04/UI\\_outletboxes.pdf](https://www.ul.com/wp-content/uploads/2014/04/UI_outletboxes.pdf), 2011, 2 pages.
- “Portland Bi-Color, Warm White/Red,” item:ILIM30941.Imtra Marine Products. 2012. 3 pages.
- “Undercabinet Pucks, Xyris Mini LED Puck Light,” ELCO Lighting. Septmeber 2018. 1 page.
- “VERSI LED Mini Flush,” Lithonia Lghting. 6 pages.
- <<https://www.zhagastandard.org/books/book18/>>, Mar. 2017, 5 pages.
- 2006 International Building Code, Section 712 Penetrations, 2006, 4 pages.
- Acrich COB Zhaga Module, Product Description, Seoul Semiconductor, Nov. 2016, 39 pages.
- Bortz, J. C. et al., “Optimal design of a nonimaging TIR doublet lens for an illumination system using an LED source”, Proc. SPIE 5529, Nonimaging Optics and Efficient Illumination Systems, (Sep. 29, 2004); doi: 10.1117/12.562598; <https://doi.org/10.1117/12.562598>, 10 pages.
- BXUV.GuidelInfo, Fire Resistance Ratings—ANSI/UL 263, UL Online Certifications Directory, last updated Nov. 3, 2016, 27 pages.
- Canadian Office Action dated Aug. 11, 2017 from Canadian Application No. 2,941,051, 4 pages.
- Canadian Office Action dated Dec. 23, 2013 from Canadian Application No. 2,778,581, 3 pages.
- Canadian Office Action dated Dec. 6, 2016 from Canadian Application No. 2,879,629, 3 pages.
- Canadian Office Action dated Feb. 1, 2016 from Canadian Application No. 2,879,486, 5 pages.
- Canadian Office Action dated Jun. 12, 2017 from Canadian Application No. 2,927,601, 4 pages.
- Canadian Office Action dated Mar. 22, 2016 from Canadian Application No. 2,879,629, 4 pages.
- Canadian Office Action dated Mar. 9, 2017 from Canadian Application No. 2,931,588, 5 pages.
- Carlson® Zip Box® Blue™ Switch and Outlet Boxes, Product Brochure, <http://www.carlonsales.com/brochures.php>, 2006, 22 pages.
- CEYY.GuidelInfo, Outlet Boxes and Fittings Certified for Fire Resistance, UL Online Certifications Directory, last updated May 16, 2013, 2 pages.
- Civil Action No. 2:18-cv-07090. Complaint for Infringement And Unfair Competition. *DMF, Inc. v. AMP Plus, Inc. d/b/a ELCO Lighting*. 52 pages. Dated Aug. 15, 2018.
- Cree LED Lamp Family Sales Sheet—Better light is beautiful light , Apr. 24, 2017, 2 pages.
- DME Series Installation Instructions, Oct. 18, 2011, 2 pages.
- DMF, Inc., “dmfLIGHTING: LED Recessed Downlighting,” DRD2 Product Brochure, Oct. 23, 2014, 50 pages.
- DMF, Inc., “dmfLIGHTING: LED Recessed Downlighting,” Product Catalog, Aug. 2012, 68 pages.
- DMF, Inc., “dmfLIGHTING: LED Recessed Lighting Solutions,” Info sheets, Mar. 15, 2012, 4 pages.
- Dross, O. et al., “Review of SMS design methods and real-world applications”, Proc. SPIE 5529, Nonimaging Optics and Efficient Illumination Systems, (Sep. 29, 2004); doi: 10.1117/12.561336; <https://doi.org/10.1117/12.561336>, 14 pages.
- Final Office Action dated Apr. 2, 2015 from U.S. Appl. No. 13/484,901, 13 pages.
- Final Office Action dated Apr. 27, 2016 from U.S. Appl. No. 14/184,601, 19 pages.
- Final Office Action dated Jan. 29, 2016 from U.S. Appl. No. 14/183,424, 21 pages.
- Final Office Action dated Jul. 26, 2017 from U.S. Appl. No. 14/184,601, 18 pages.
- Final Office Action dated Jun. 23, 2016 from U.S. Appl. No. 13/484,901, 18 pages.
- Halo, H7 LED Downlight Trims 49x Series, 6-inch LED Trims for Use with MI7x LED Modules, Cooper Lighting, ADV110422, rev. Aug. 12, 2011, 15 pages.
- Halo, Halo LED H4 H7 Collection, SustainabLEDesign, Cooper Lighting, (emphasis on p. 18 “H7 Collection LED Modules—Halo LED H7 Module Features,”) Mar. 28, 2012, 52 pages.
- Halo, LED Module ML706x, Cooper Lighting, General Installation for All Modules/p. 1; Tether Installation/pp. 2-3; Installation into HALO H750x Series LED—only (Non-Screw Based), Recessed Fixture, p. 4, Oct. 20, 2009, 4 pages.
- International Search Report and Written Opinion in International Patent Application No.: PCT/US18/39048 dated Dec. 14, 2018. 24 pages.
- International Search Report and Written Opinion in PCT/US2018/048357 dated Nov. 14, 2018, 13 pages.
- Medvedev, V. et al., “Uniform LED illuminator for miniature displays,” Proc. SPIE 3428, Illumination and Source Engineering, (Oct. 20, 1998); doi: 10.1117/12.327957; <https://doi.org/10.1117/12.327957>, 13 pages.
- Non-Final Office Action dated Apr. 12, 2018 for U.S. Appl. No. 29/638,259, 5 pages.
- Non-Final Office Action dated Apr. 30, 2010 from U.S. Appl. No. 12/173,232, 13 pages.
- Non-Final Office Action dated Dec. 15, 2016 from U.S. Appl. No. 14/184,601, 18 pages.
- Non-Final Office Action dated Dec. 5, 2018 from U.S. Appl. No. 14/942,937, 13 pages.
- Non-Final Office Action dated Feb. 6, 2018 from U.S. Appl. No. 15/167,682, 9 pages.
- Non-Final Office Action dated Jul. 20, 2015 from U.S. Appl. No. 14/184,601, 16 pages.
- Non-Final Office Action dated Jun. 2, 2015 from U.S. Appl. No. 14/183,424, 20 pages.
- Non-Final Office Action dated Jun. 25, 2018 for U.S. Appl. No. 29/541,565, 10 pages.
- Non-Final Office Action dated Mar. 15, 2010 from U.S. Appl. No. 12/100,148, 8 pages.
- Non-Final Office Action dated May 16, 2018 for U.S. Appl. No. 15/132,875, 18 pages.
- Non-Final Office Action dated May 17, 2017 from U.S. Appl. No. 14/183,424, 20 pages.
- Non-Final Office Action dated Oct. 16, 2014 from U.S. Appl. No. 13/484,901, 11 pages.
- Non-Final Office Action dated Oct. 24, 2018 for U.S. Appl. No. 15/688,266, 14 pages.
- Non-Final Office Action dated Sep. 15, 2015 from U.S. Appl. No. 13/484,901, 16 pages.
- Non-Final Office Action dated Sep. 5, 2014 from U.S. Appl. No. 13/791,087, 8 pages.
- Non-Final Office Action dated Sep. 6, 2017 from U.S. Appl. No. 14/726,064, 8 pages.
- Notice of Allowance dated Aug. 23, 2017 from Canadian Application No. 2,879,629, 1 page.
- Notice of Allowance dated Jan. 16, 2015 from U.S. Appl. No. 29/467,026, 9 pages.
- Notice of Allowance mailed Jan. 2, 2019 from U.S. Appl. No. 29/541,565, 6 pages.
- Notice of Allowance dated Jan. 30, 2015 from U.S. Appl. No. 13/791,087, 9 pages.
- Notice of Allowance dated Mar. 24, 2016 from U.S. Appl. No. 14/247,149, 8 pages.
- Notice of Allowance dated Mar. 26, 2018 for U.S. Appl. No. 14/184,601, 10 pages.
- Notice of Allowance dated May 10, 2018 from U.S. Appl. No. 14/726,064, 7 pages.
- Notice of Allowance dated May 22, 2018 from U.S. Appl. No. 14/183,424, 9 pages.
- Notice of Allowance mailed Nov. 27, 2018 from U.S. Appl. No. 15/167,682, 11 pages.



(56)

**References Cited**

## OTHER PUBLICATIONS

Notice of Allowance dated Oct. 21, 2016 from U.S. Appl. No. 13/484,901, 7 pages.

Notice of Allowance dated Oct. 4, 2018 from U.S. Appl. No. 15/947,065, 9 pages.

Notice of Allowance dated Oct. 9, 2018 from U.S. Appl. No. 29/653,142, 7 pages.

Notice of Allowance dated Sep. 19, 2018 from U.S. Appl. No. 15/167,682, 7 pages.

Notice of Allowance dated Sep. 21, 2018 from U.S. Appl. No. 29/645,941, 5 pages.

OneFrame Recessed LED Downlight. Dmflighting.com. Published Jun. 6, 2018. Retrieved at <https://www.dmflighting.com/product/oneframe> on Jun. 6, 2018. 11 pages.

RACO 4 in. Octagon Welded Concrete Ring, 3-1/2 in. Deep with 1/2 and 3/4 in. Knockouts and includes 890 cover (20-Pack). Model # 280. Accessed at <https://www.homedepot.com/p/RACO-4-in-Octagon-Welded-Concrete-Ring-3-1-2-in-Deep-with-1-2-and-3-4-in-Knockouts-and-includes-890-cover-20-Pack-280/203638679> on Jan. 18, 2019. 3 pages.

RACO 4 in. Octagon Welded Concrete Ring, 6 in. Deep with 1/2 and 3/4 in. Knockouts (10-Pack). Model # 276. Accessed at <https://www.homedepot.com/p/RACO-4-in-Octagon-Welded-Concrete-Ring-6-in-Deep-with-1-2-and-3-4-in-Knockouts-10-Pack-276/203638675> on Jan. 16, 2019. 4 pages.

Non-Final Office Action dated Feb. 7, 2019 from U.S. Appl. No. 16/200,393, 32 pages.

Non-Final Office Action dated Jul. 24, 2018 from U.S. Appl. No. 29/638,259, 5 pages.

Notice of Allowance dated Feb. 8, 2019 from U.S. Appl. No. 29/541,565, 5 pages.

Notice of Allowance dated Jan. 28, 2019 from U.S. Appl. No. 29/664,471, 8 pages (DMFI-008DUS03).

U.S. Appl. No. 29/683,730, filed Mar. 15, 2019, Danesh et al.

U.S. Appl. No. 29/694,475, filed Jun. 11, 2019, Peng et al.

Notice of Allowance dated Jul. 31, 2019 from U.S. Appl. No. 15/167,682, 7 pages.

Supplemental Notice of Allowance dated Aug. 5, 2019 from U.S. Appl. No. 15/947,065, 2 pages.

International Search Report and Written Opinion in International Patent Application No. PCT/US19/32281 dated Aug. 2, 2019, 18 pages.

4" Octagon Concrete Boxes and Back Plates. Appleton. Accessed at [www.appletonelec.com](http://www.appletonelec.com) on May 6, 2019. 1 page.

Cooper Lighting Halo ML56 LED System Product Sheet. Mar. 2, 2015. Accessed at [http://www.cooperindustries.com/content/dam/public/lighting/products/documents/halo/spec\\_sheets/halo-ml56600-80cri-141689-sss.pdf](http://www.cooperindustries.com/content/dam/public/lighting/products/documents/halo/spec_sheets/halo-ml56600-80cri-141689-sss.pdf). 8 pages.

CS&E PCT Collaborative Search and Examination Pilot Upload Peer Contribution in International Patent Application No. PCT/US18/62868 dated Mar. 14, 2019, 61 pages.

CS&E PCT Collaborative Search and Examination Pilot Upload Peer Contribution in International Patent Application No. PCT/US18/67614 dated Apr. 24, 2019, 53 pages.

Ex-Parte Quayle Action dated Jun. 27, 2019 from U.S. Appl. No. 29/683,730, 5 pages.

Final Office Action dated Jun. 6, 2019 from U.S. Appl. No. 15/688,266, 7 pages.

Final Office Action dated Mar. 15, 2019 from U.S. Appl. No. 15/132,875, 15 pages.

IC1JB Housing 4" IC-Rated New Construction Junction Box Housing. AcuityBrands. Accessed at <https://www.acuitybrands.com/en/products/detail/845886/juno/ic1jb-housing/4-ic-rated-new-construction-junction-box-housing> on Jun. 27, 2019.

Imtra Marine Lighting 2008 Catalog. 40 pages.

Imtra Marine Lighting 2009 Catalog. 32 pages.

Imtra Marine Lighting Spring 2007 Catalog. 36 pages.

International Search Report and Written Opinion in International Patent Application No. PCT/US18/62868 dated Mar. 14, 2019, 13 pages.

International Search Report and Written Opinion in International Patent Application No. PCT/US18/67614 dated Apr. 25, 2019, 20 pages.

Kwikbrace® New Construction Braces for Lighting Fixtures or Ceiling Fans 1-1/2 in. Depth. Hubbel. Accessed at <https://hubbellcdn.com/specsheet/926.pdf> on Jun. 27, 2019. 1 page.

Non-Final Office Action dated Apr. 4, 2019 from U.S. Appl. No. 29/678,482, 8 pages.

Non-Final Office Action dated Jun. 11, 2019 from U.S. Appl. No. 15/901,738, 6 pages.

Notice of Allowance dated Apr. 1, 2019 from U.S. Appl. No. 15/167,682, 7 pages.

Notice of Allowance dated Apr. 8, 2019 from U.S. Appl. No. 29/653,142, 8 pages.

Notice of Allowance dated Jun. 12, 2019 from U.S. Appl. No. 16/016,040, 8 pages.

RACO Commercial, Industrial and Residential Electrical Products. Hubbell. Accessed at [www.Hubbell-RTB.com](http://www.Hubbell-RTB.com) on May 6, 2019. 356 pages.

Specification & Features 4" Octagonal Concrete Box Covers. Orbit Industries, Inc. Accessed at <https://www.orbitelectric.com> on May 6, 2019. 1 page.

\* cited by examiner

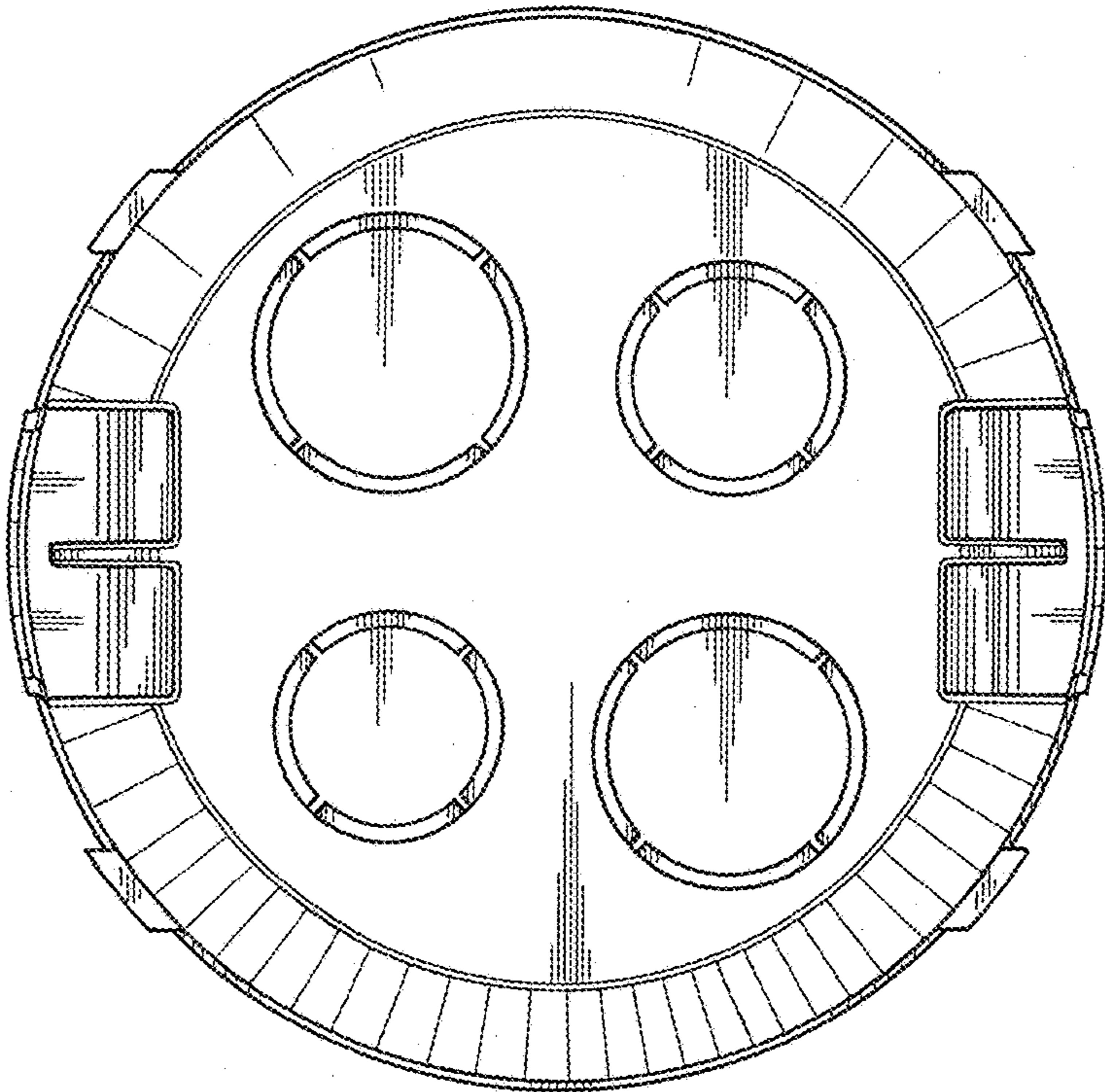

FIG. 1



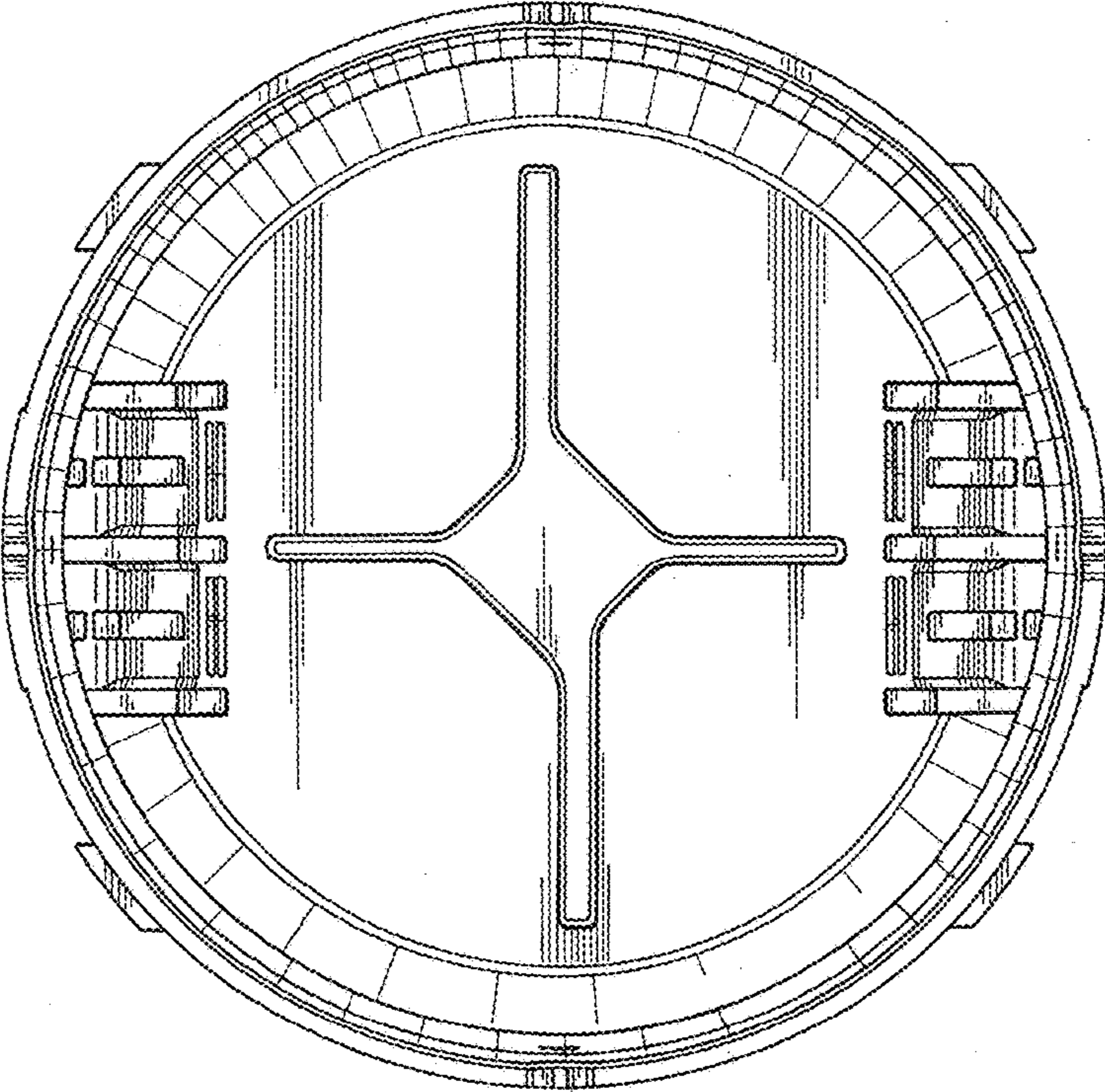

FIG. 2



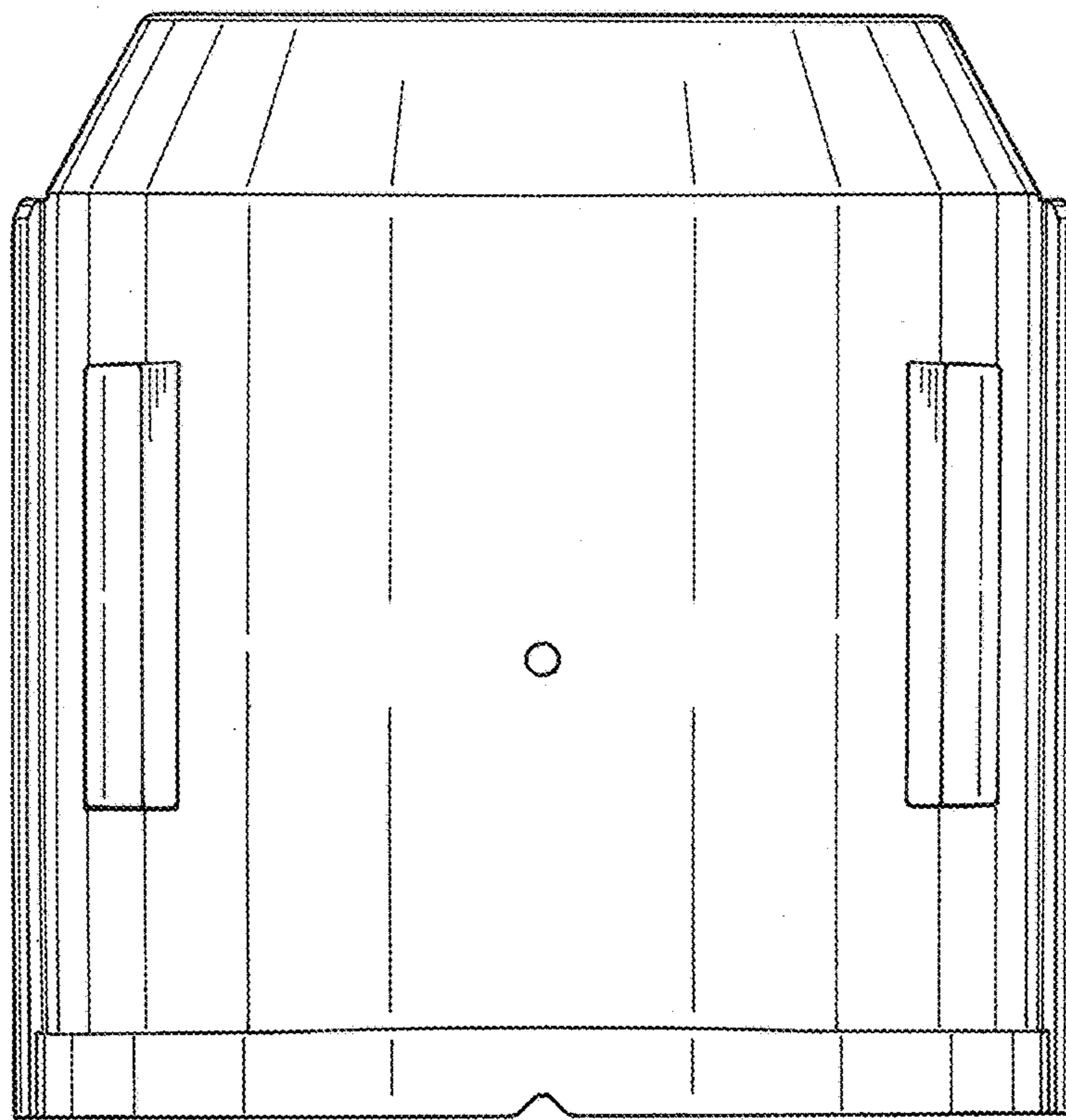

FIG. 3



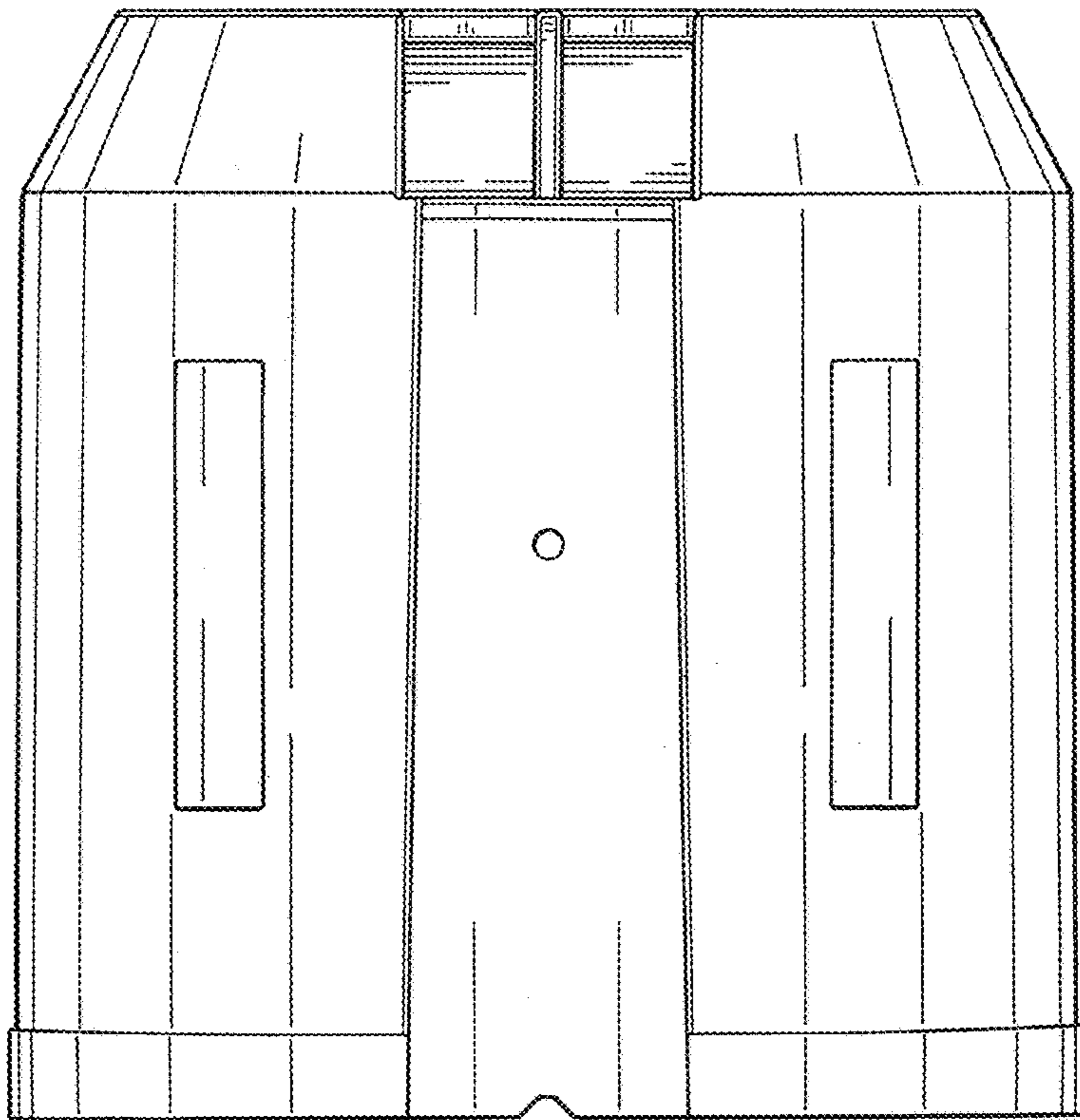

FIG. 4



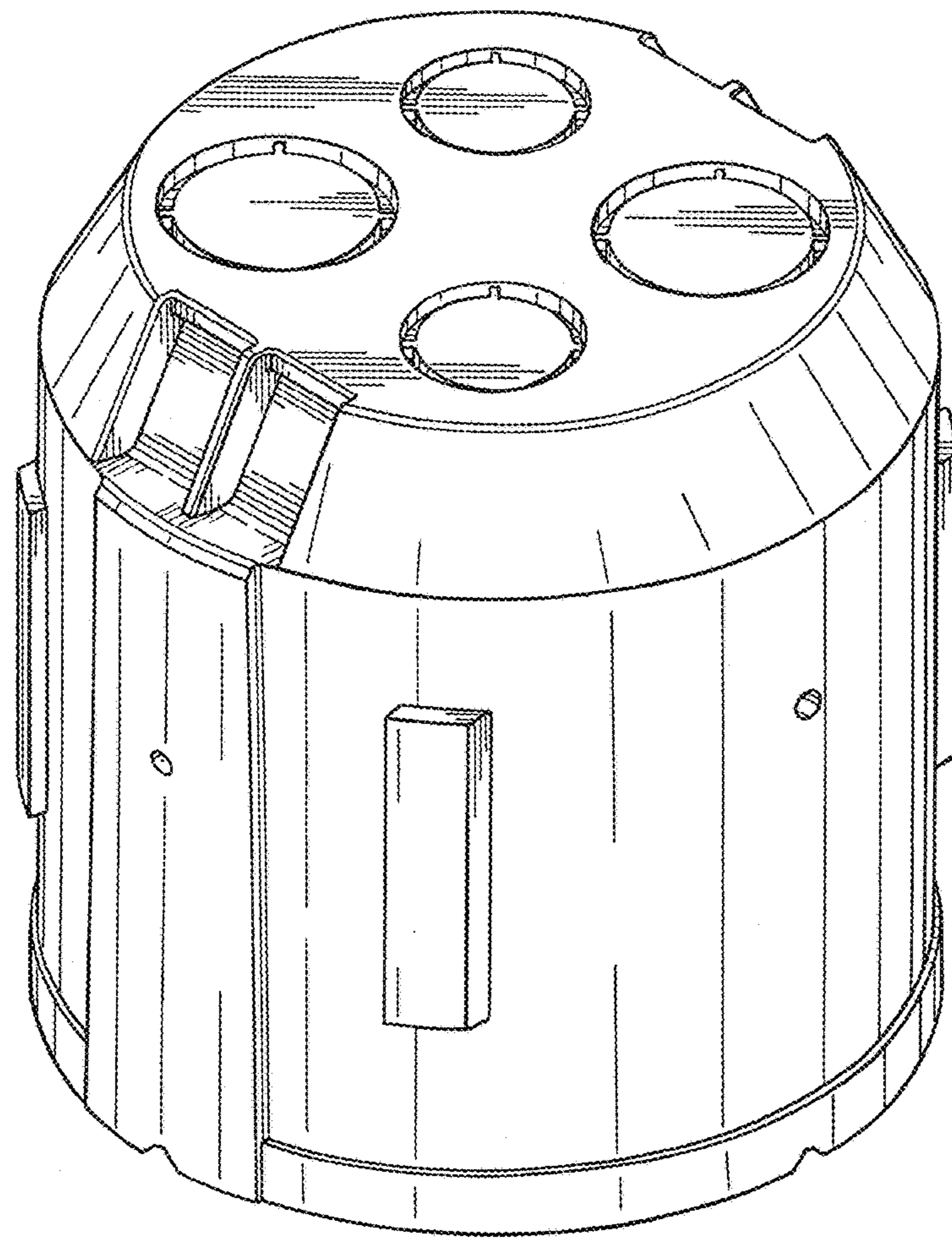

FIG. 5

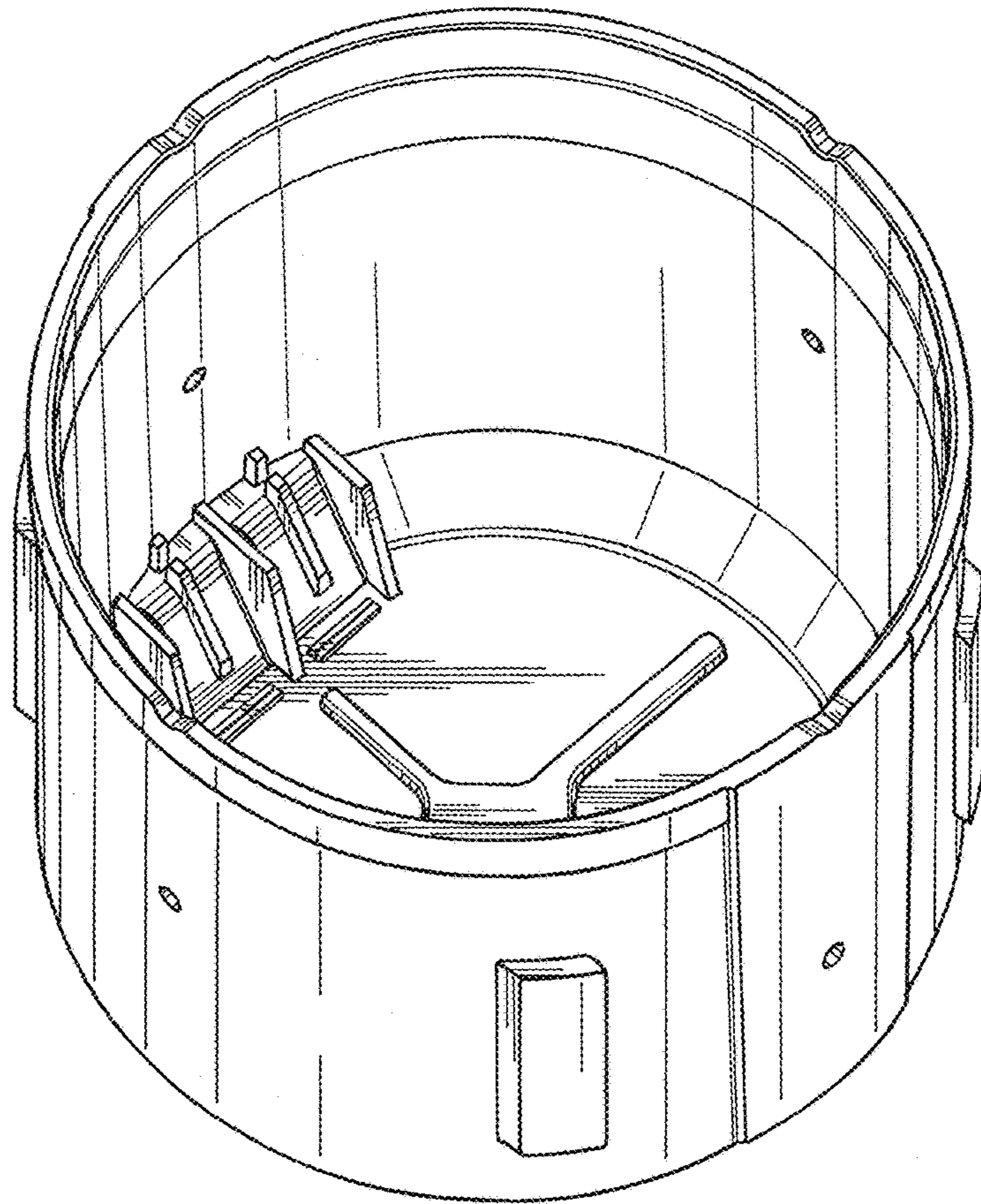

FIG. 6



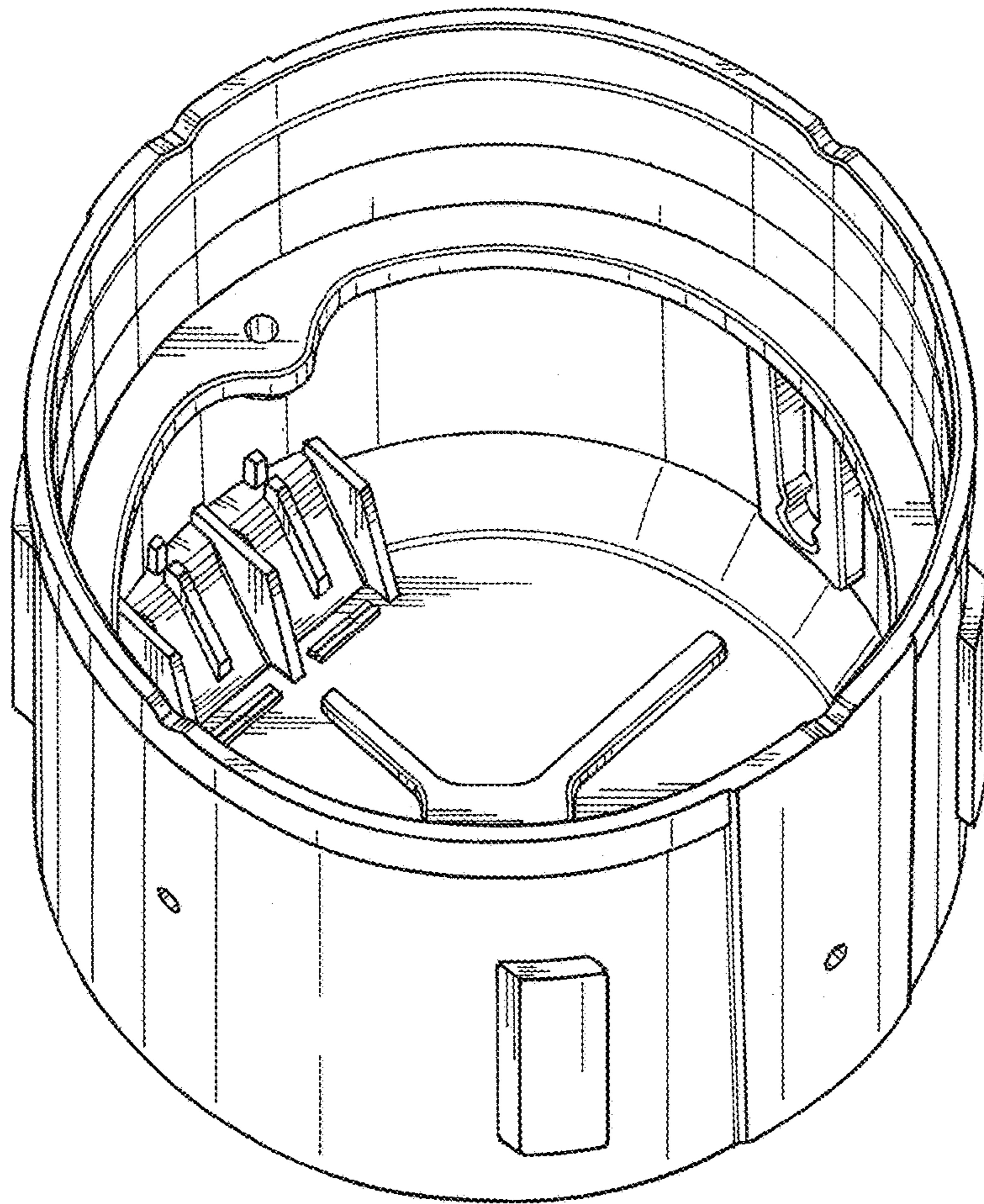

FIG. 7

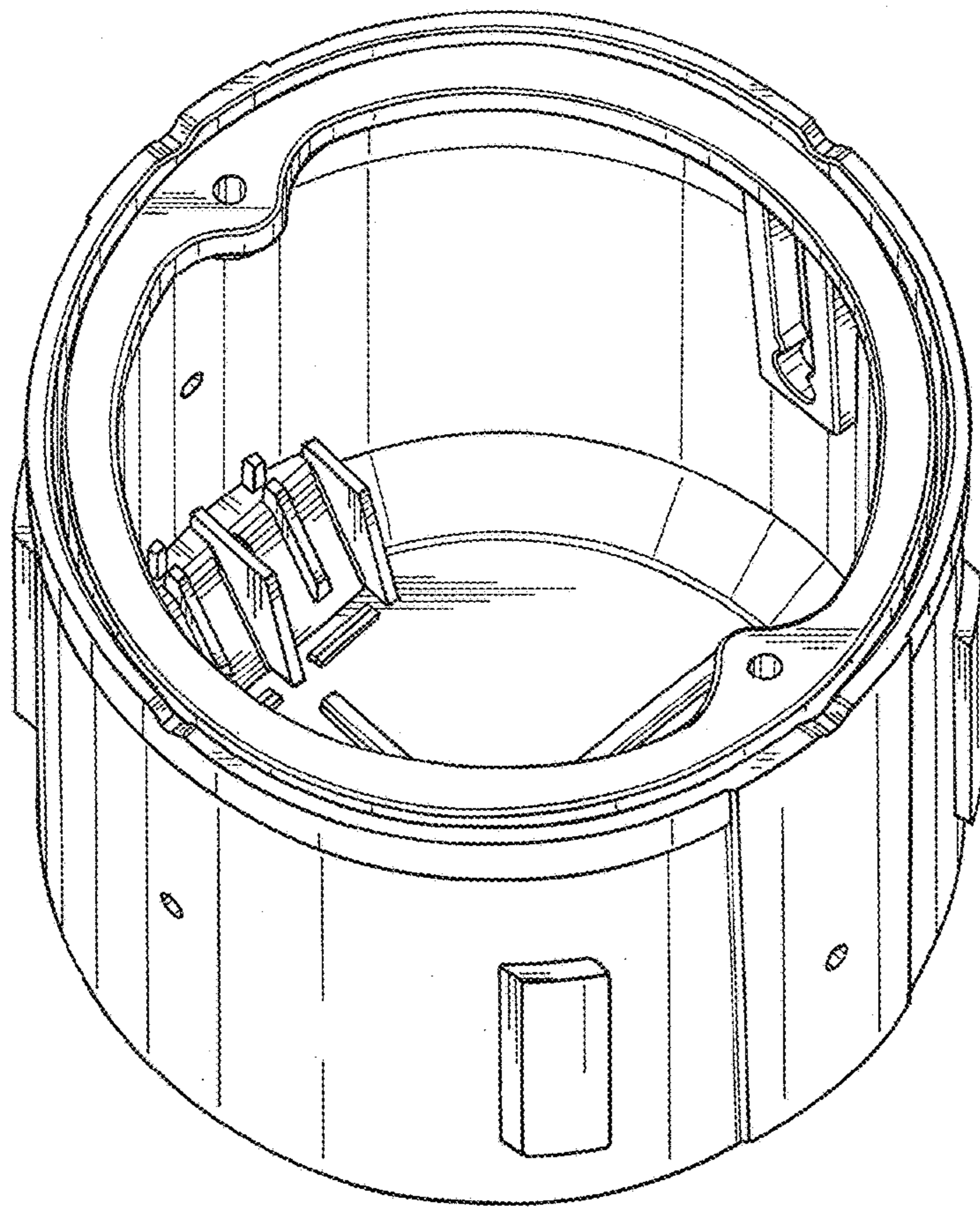

FIG. 8



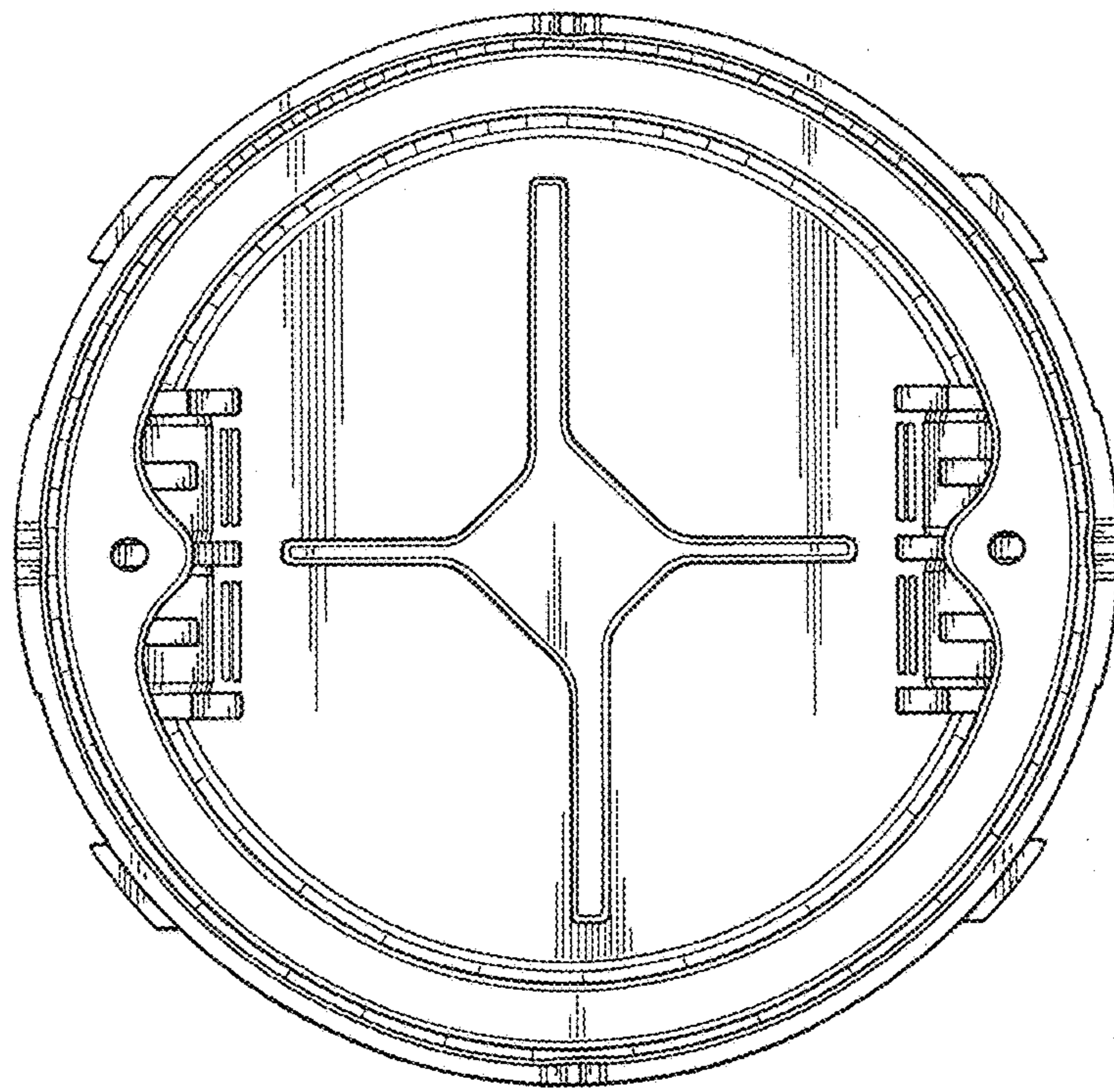

FIG. 9

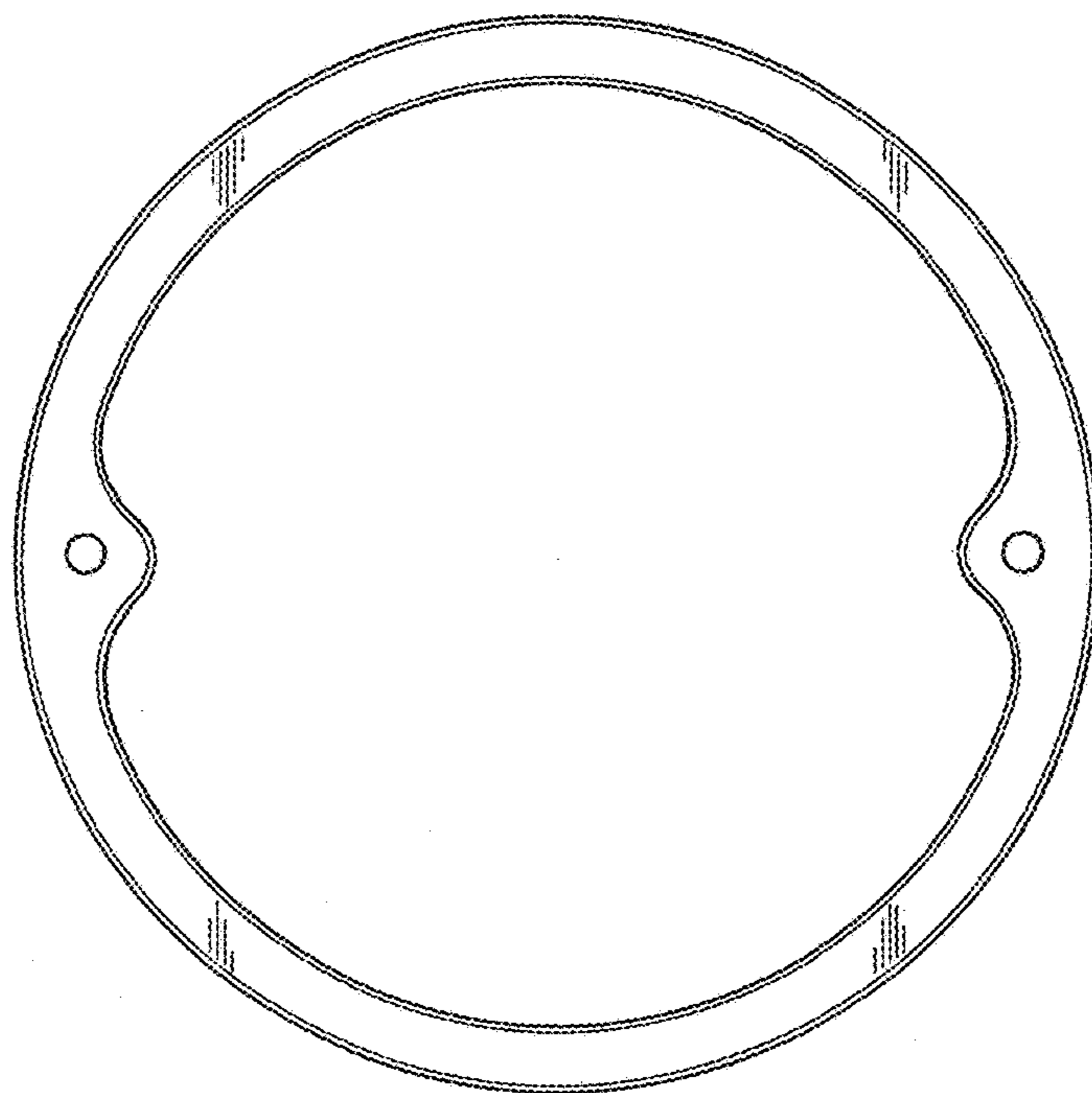

FIG. 10



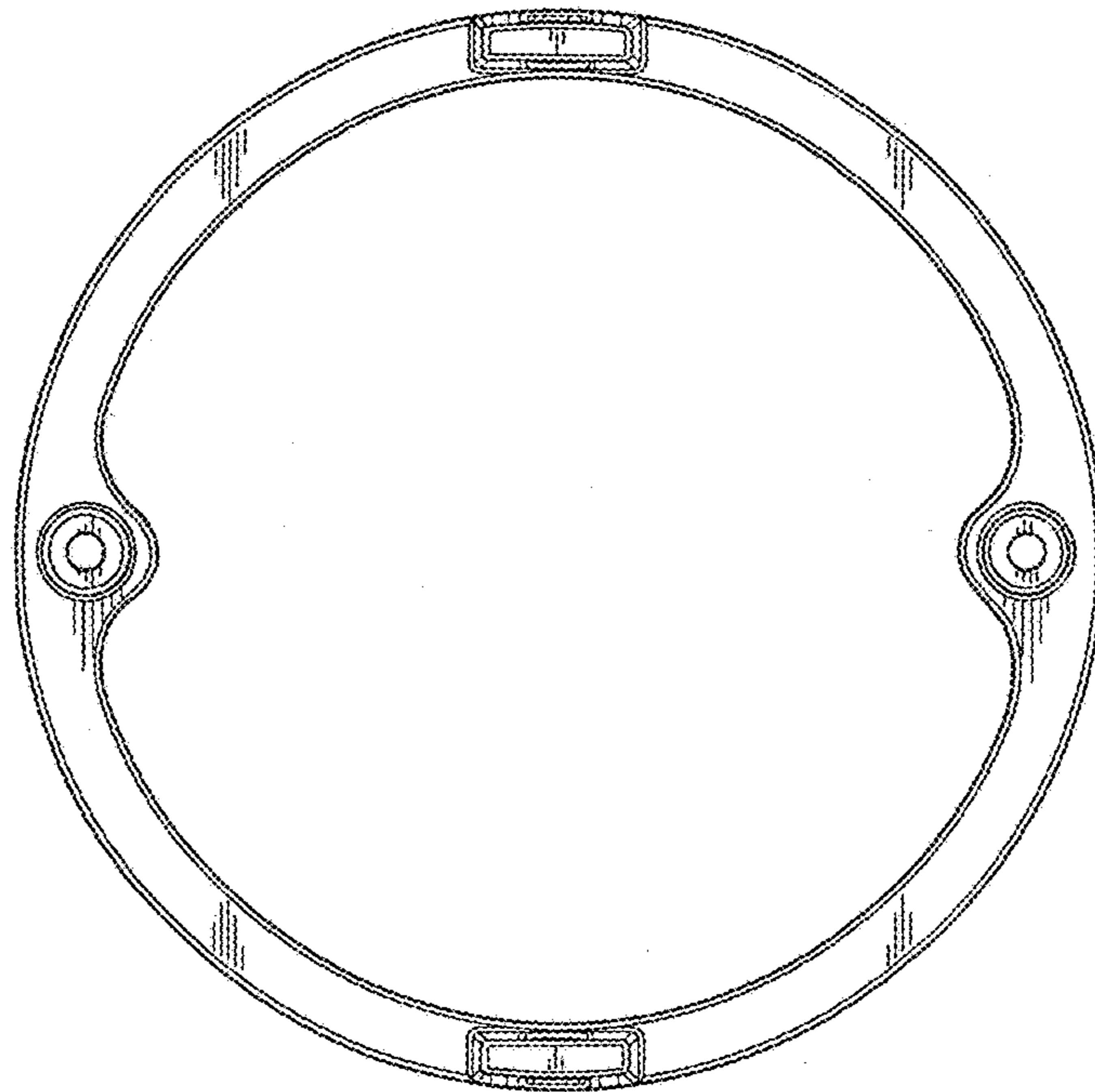

FIG. 11

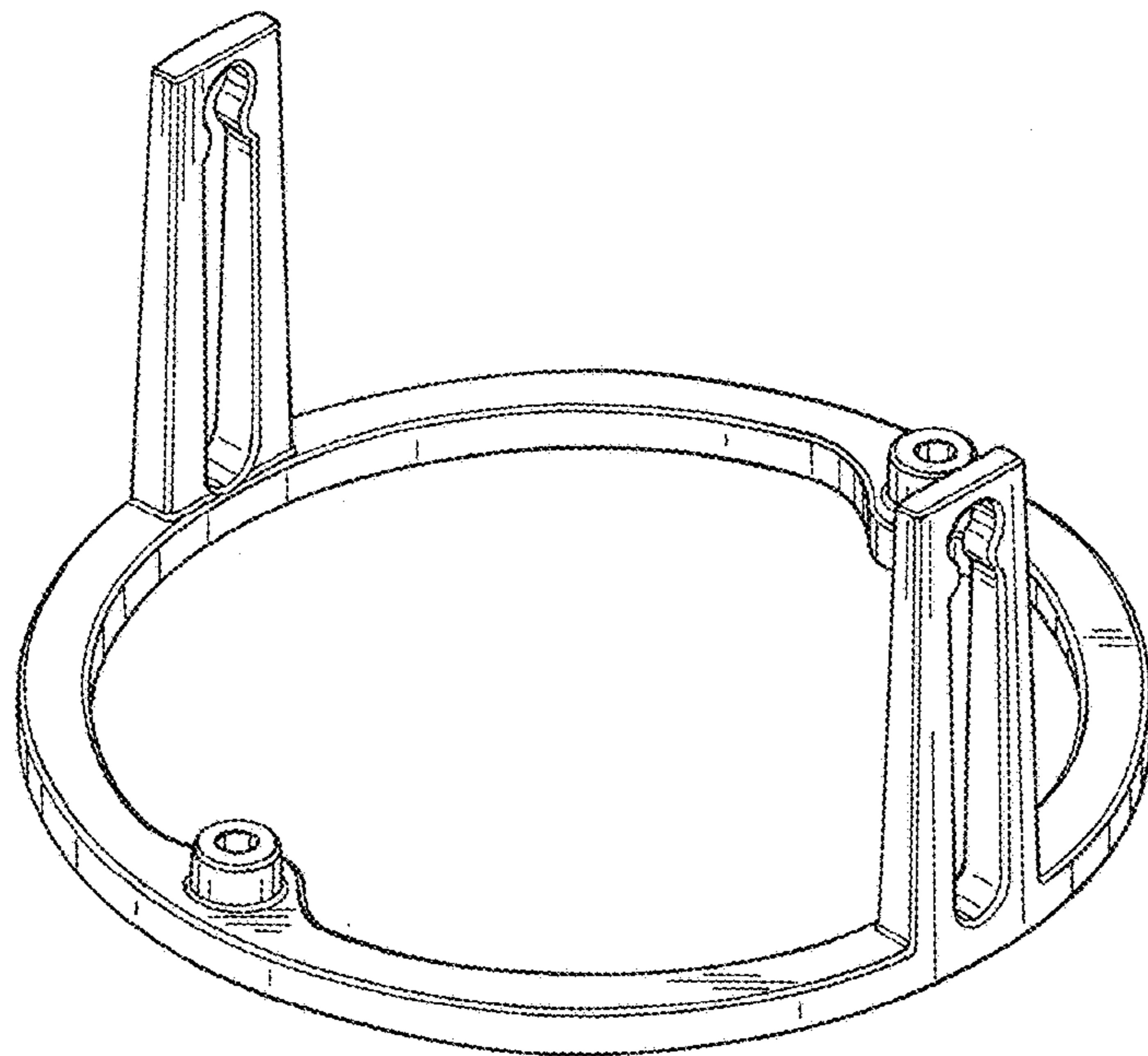

FIG. 12