



US00D864796S

(12) **United States Design Patent**
Grossjohann

(10) **Patent No.:** **US D864,796 S**

(45) **Date of Patent:** **** Oct. 29, 2019**

(54) **BALANCE BIKE**
(71) Applicant: **TRELOGO KG**, Noervenich (DE)
(72) Inventor: **Benjamin Grossjohann**, Bonn (DE)
(73) Assignee: **TRELOGO KG**, Noervenich (DE)
(**) Term: **15 Years**

(21) Appl. No.: **35/504,973**

(22) Filed: **Mar. 2, 2018**

(80) **Hague Agreement Data**

Int. Filing Date: **Mar. 2, 2018**
Int. Reg. No.: **DM/101022**
Int. Reg. Date: **Mar. 2, 2018**
Int. Reg. Pub. Date: **May 18, 2018**

(51) **LOC (12) Cl.** **12-11**

(52) **U.S. Cl.**
USPC **D12/111; D21/435**

(58) **Field of Classification Search**
USPC D12/11, 111; D21/432, 435, 538
CPC B62K 9/02; B62K 15/00; B62K 15/008;
B62K 21/00; B62J 17/08
See application file for complete search history.

(56) **References Cited**

U.S. PATENT DOCUMENTS

D326,247 S * 5/1992 Hess D12/111
D504,845 S * 5/2005 Coerschulte D12/111
D512,664 S * 12/2005 Schreier D12/111
D537,758 S * 3/2007 Grepper D12/111
D567,149 S * 4/2008 Grepper D12/111

D597,147 S * 7/2009 Verlinden D21/424
D629,049 S * 12/2010 McFarland B62K 9/00
D12/111
D659,597 S * 5/2012 Chen D12/111
D668,586 S * 10/2012 Golias D12/111
8,286,974 B2 * 10/2012 Chen B62K 9/00
280/1.188
D671,173 S * 11/2012 Tompkin D12/111
8,414,007 B2 * 4/2013 Chen B62K 15/006
280/278
D695,847 S * 12/2013 Liu D12/111
D729,700 S * 5/2015 De Roeck D12/111
D735,620 S * 8/2015 Pape B62K 9/00
D12/111
D739,308 S * 9/2015 Barnaby Latham D12/111
D781,753 S * 3/2017 Wunderlin D12/111

* cited by examiner

Primary Examiner — Darlington Ly
(74) *Attorney, Agent, or Firm* — McGlew and Tuttle, P.C.

(57) **CLAIM**

The ornamental design for a balance bike, as shown and described.

DESCRIPTION

1 . Balance bike
1.1 is a top, front, and right side perspective view of a balance bike showing my new design;
1.2 is a top, rear, and right side perspective view thereof;
1.3 is a top plan view thereof;
1.4 is a right side elevation view thereof; and
1.5 is a front elevation view thereof.
The broken lines in the drawings illustrate portions of the balance bike that form no part of the claimed design.

1 Claim, 5 Drawing Sheets

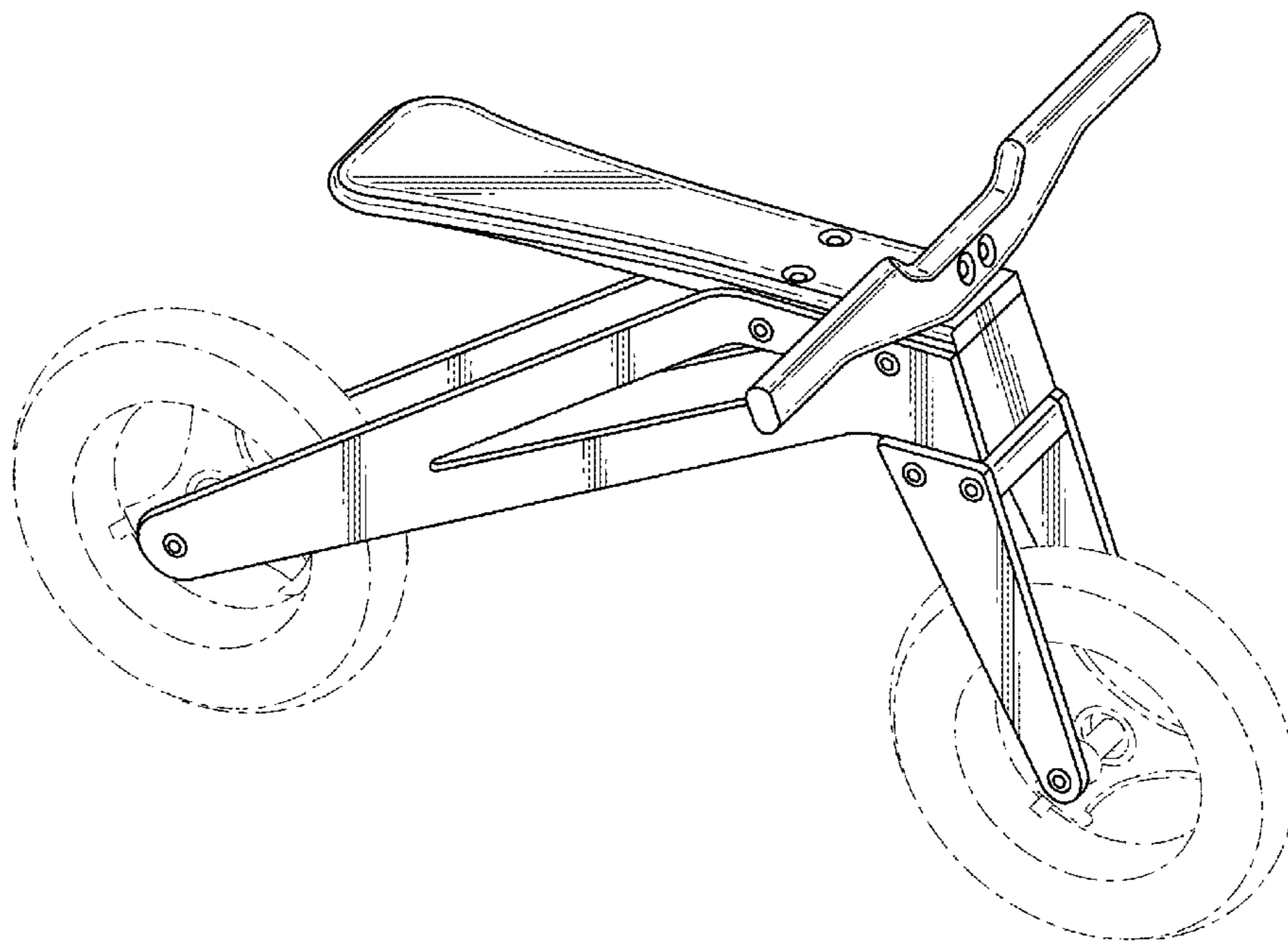

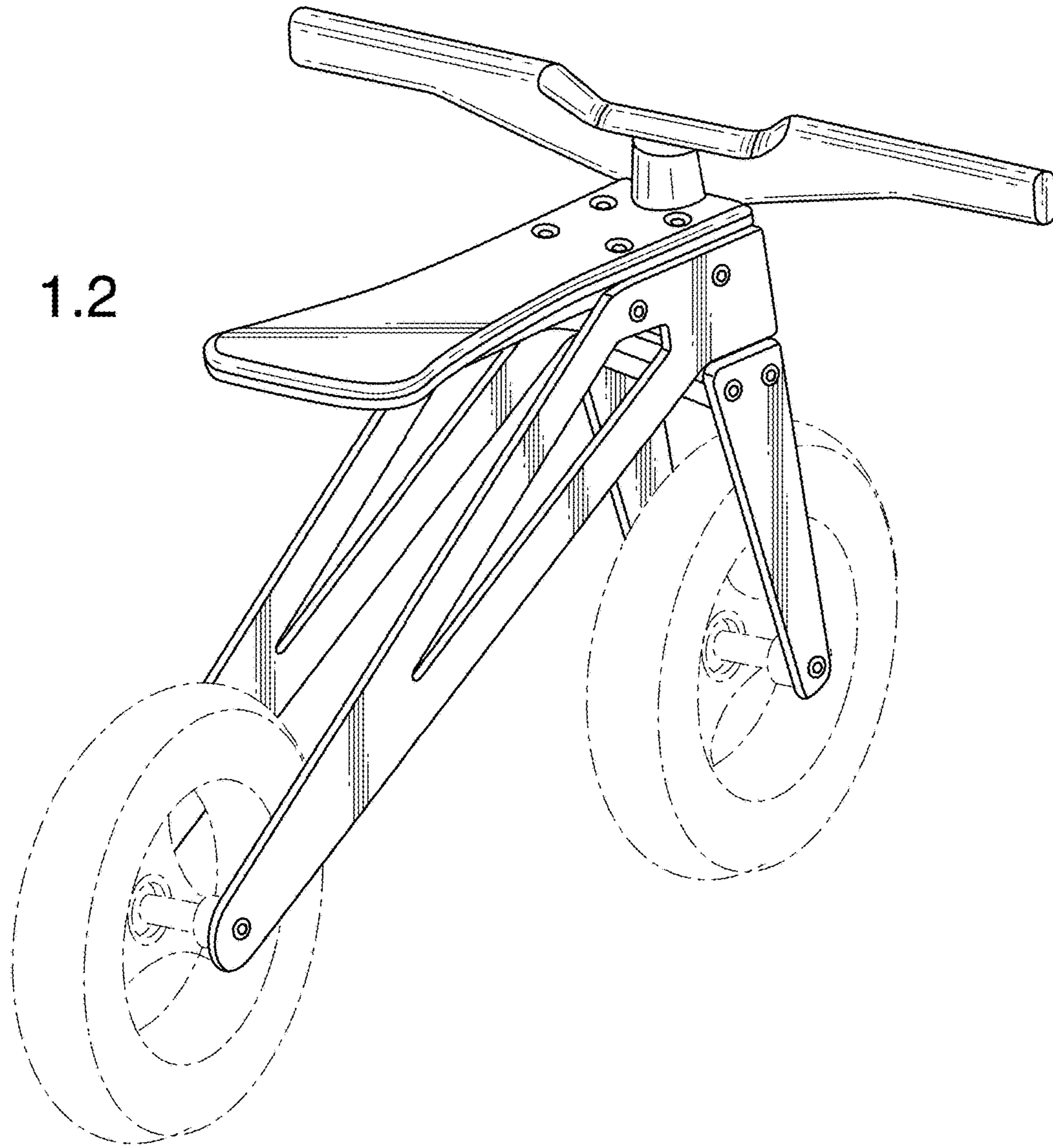

1.3

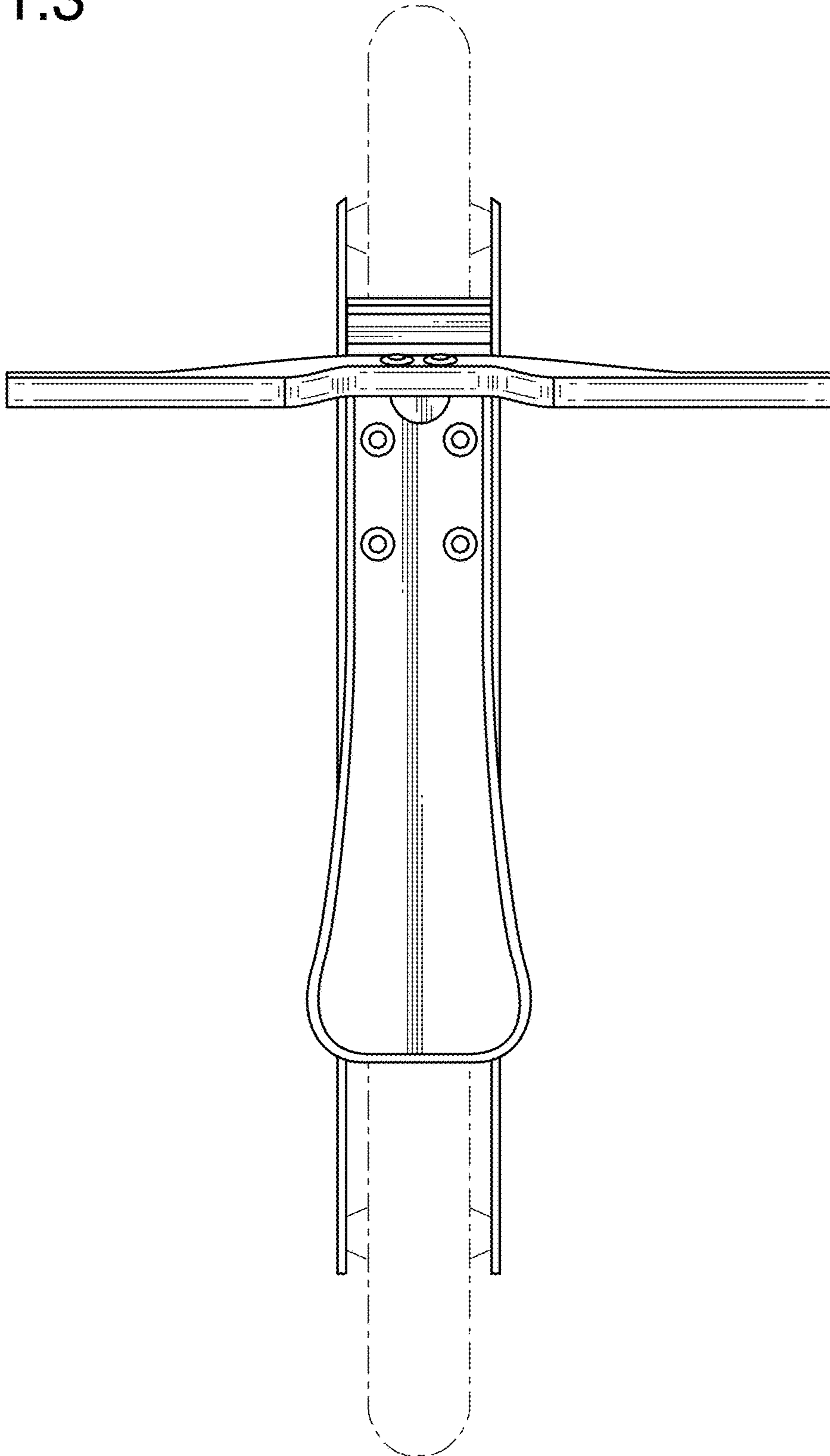

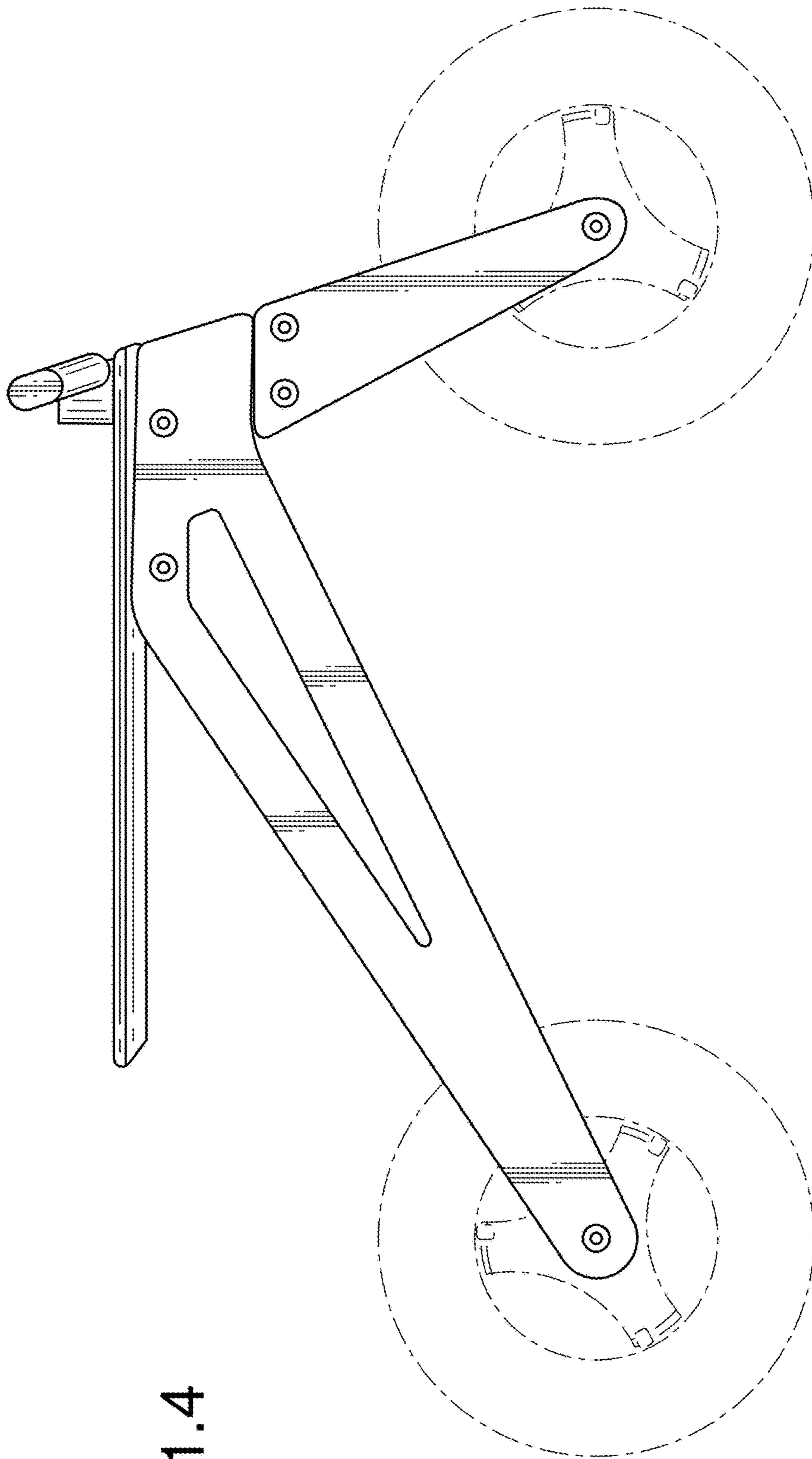

1.4

1.5

