



US00D864688S

(12) **United States Design Patent**  
**Hochstrasser**

(10) **Patent No.:** **US D864,688 S**  
(45) **Date of Patent:** **\*\* Oct. 29, 2019**

(54) **STRAPPING DEVICE**

- (71) Applicant: **Signode Industrial Group LLC**,  
Glenview, IL (US)
- (72) Inventor: **Samuel Hochstrasser**, Fällanden (CH)
- (73) Assignee: **Signode Industrial Group LLC**,  
Glenview, IL (US)
- (\*\*) Term: **15 Years**
- (21) Appl. No.: **29/598,733**
- (22) Filed: **Mar. 28, 2017**
- (51) **LOC (12) Cl.** ..... **08-01**
- (52) **U.S. Cl.**  
USPC ..... **D8/61; D15/145**
- (58) **Field of Classification Search**  
USPC ..... D8/41, 61, 67; D15/122, 145, 146, 199  
CPC ..... B65B 13/00; B65B 13/06; B65B 13/16;  
B65B 13/18; B65B 13/32; B65B 13/285;  
B65B 57/04; B65B 59/04; B65B 2210/12;  
E04G 21/122; E04G 21/123  
See application file for complete search history.

(56) **References Cited**

**U.S. PATENT DOCUMENTS**

- 2,194,108 A \* 3/1940 Wright ..... B65B 13/02  
100/26
- 2,707,429 A \* 5/1955 Leslie, II ..... B65B 13/06  
100/12
- 3,013,589 A 12/1961 Holford
- 3,120,171 A \* 2/1964 Hall ..... B65B 13/34  
100/26
- 3,232,217 A \* 2/1966 Harmon ..... B65B 13/06  
100/26
- 3,367,374 A 2/1968 Meier et al.
- 3,654,033 A 4/1972 Angarola et al.

(Continued)

**FOREIGN PATENT DOCUMENTS**

- CA 2 432 353 12/2003
- CH 705 745 5/2013

(Continued)

**OTHER PUBLICATIONS**

Orgapack ORT-250 Automatic Sealless Combo Strapping Tool, located online at [www.uline.com/Product/Detail/H-2385/Poly-Strapping\\_Tools/Orgapack-ORT-250-Automatic-Sealless-Combo-Strapping-Tool.com](http://www.uline.com/Product/Detail/H-2385/Poly-Strapping_Tools/Orgapack-ORT-250-Automatic-Sealless-Combo-Strapping-Tool.com), available prior to Jan. 30, 2017 (1 page).

(Continued)

*Primary Examiner* — Patricia A Palasik

(74) *Attorney, Agent, or Firm* — Neal, Gerber & Eisenberg LLP

(57) **CLAIM**

The ornamental design for a strapping device, as shown and described.

**DESCRIPTION**

FIG. 1 is a front top right-side perspective view of a strapping device of one embodiment of our new design. FIG. 2 is a front elevational view of the strapping device of FIG. 1. FIG. 3 is a rear elevational view of the strapping device of FIG. 1. FIG. 4 is a right-side elevational view of the strapping device of FIG. 1. FIG. 5 is a left-side elevational view of the strapping device of FIG. 1. FIG. 6 is a top plan view of the strapping device of FIG. 1. FIG. 7 is a bottom plan view of the strapping device of FIG. 1; and, FIG. 8 is a rear bottom left-side perspective view of the strapping device of FIG. 1. The broken lines showing parts of the drawings form no part of the claimed design.

**1 Claim, 8 Drawing Sheets**

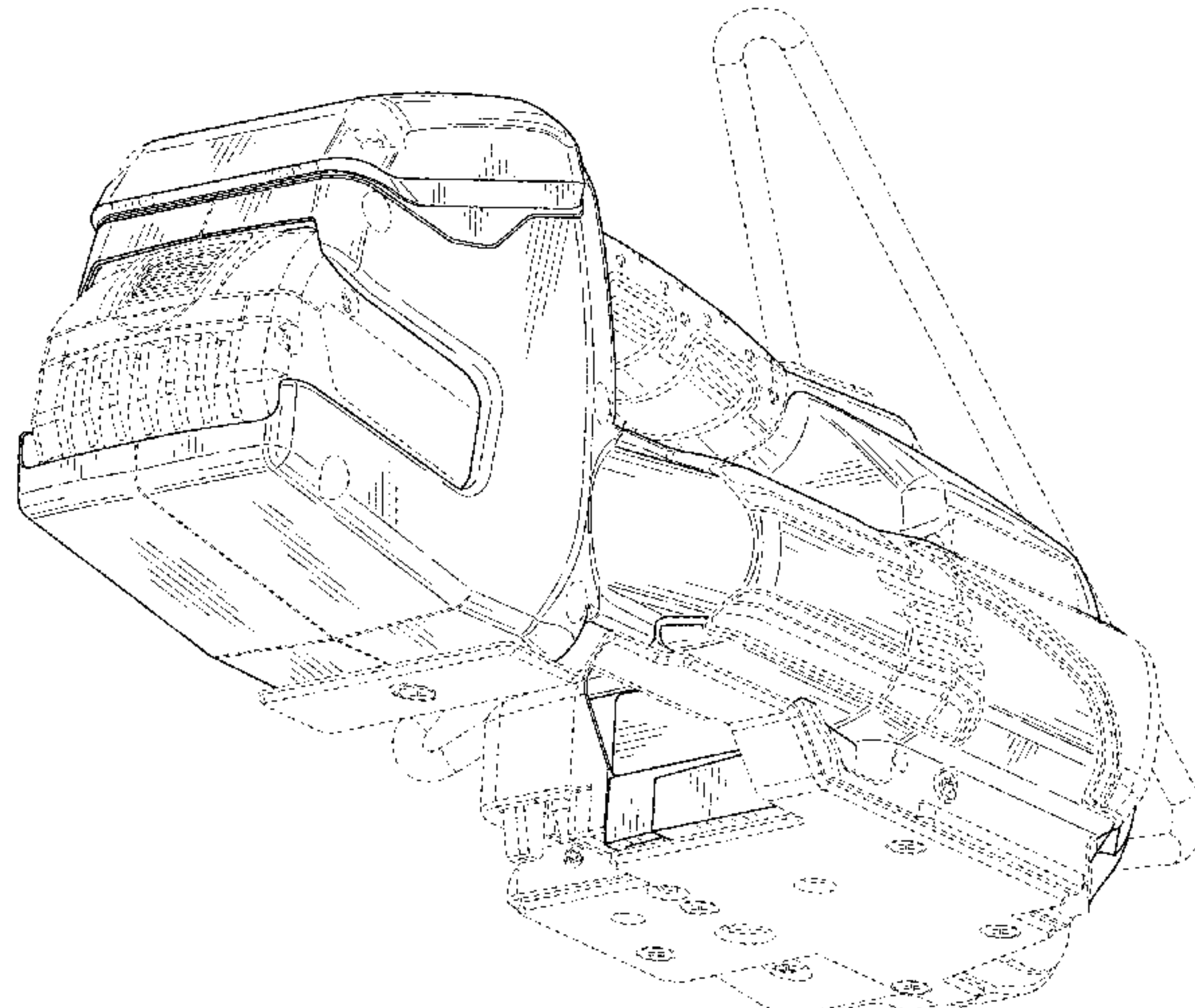
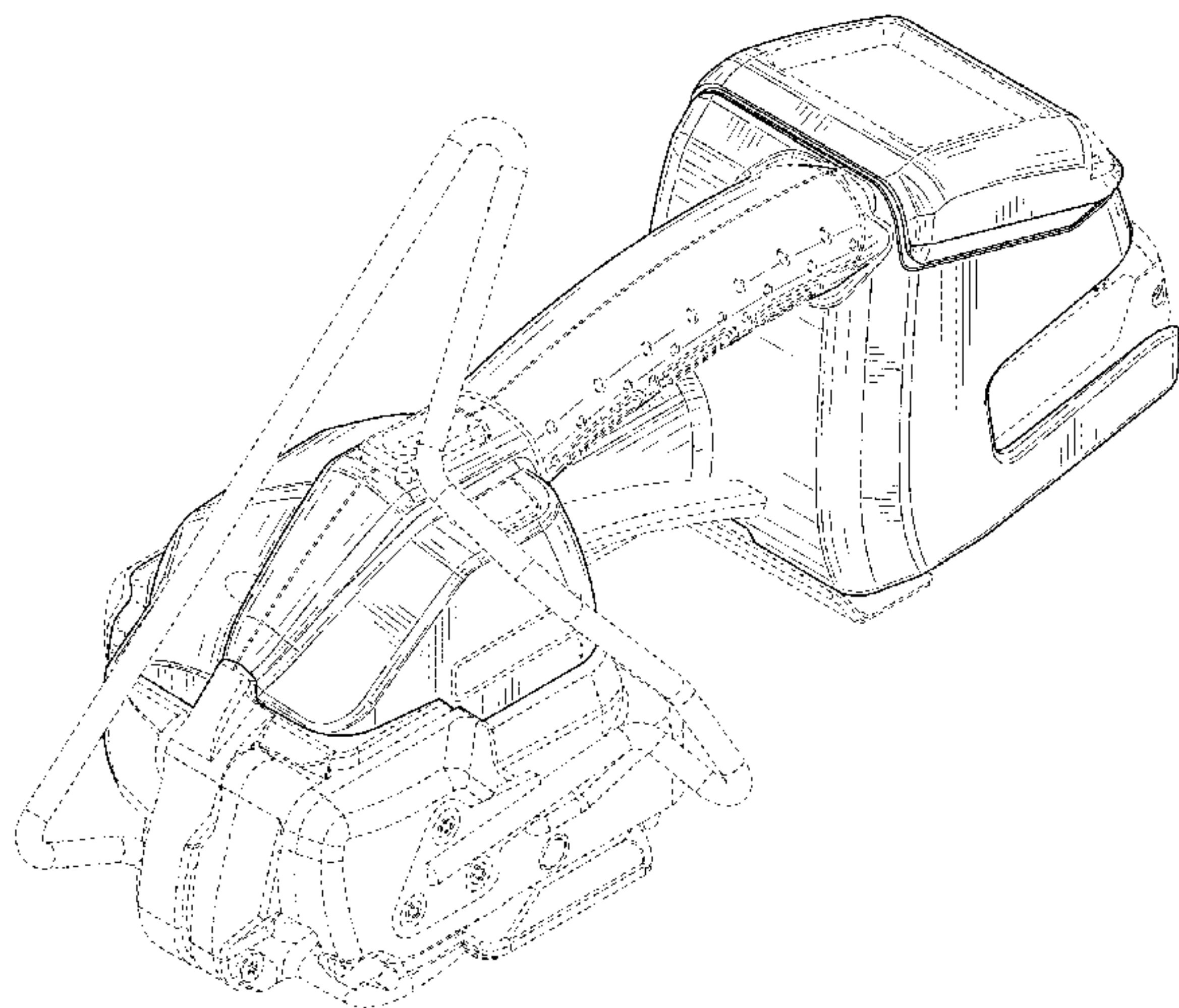



(56)		References Cited						
U.S. PATENT DOCUMENTS				7,263,928	B1 *	9/2007	Holden	B65B 13/06
								100/26
				7,270,055	B1 *	9/2007	Haberstroh	B65B 13/22
								100/26
4,011,807	A	3/1977	Kobiella	7,312,609	B2	12/2007	Schmollngruber et al.	
4,015,643	A	4/1977	Cheung	7,456,608	B2	11/2008	Kageler et al.	
4,050,372	A	9/1977	Kobiella	D629,321	S	12/2010	Neeser et al.	
4,240,865	A	12/1980	Kyts	D651,498	S	1/2012	Neeser et al.	
4,313,779	A	2/1982	Nix	D653,923	S	2/2012	Neeser et al.	
4,450,032	A	5/1984	Wehr	8,198,839	B2	6/2012	Katou et al.	
4,495,972	A	1/1985	Walker	8,378,600	B2	2/2013	Katou et al.	
4,502,911	A *	3/1985	Discavage	8,967,217	B2	3/2015	Gardner et al.	
								B65B 13/32
								100/33 PB
4,534,817	A	8/1985	O'Sullivan	9,174,752	B2	11/2015	Neeser et al.	
4,535,730	A	8/1985	Allen	9,193,486	B2	11/2015	Neeser et al.	
4,572,064	A	2/1986	Burton et al.	9,254,932	B2	2/2016	Neeser et al.	
4,707,390	A	11/1987	Cheung	9,284,080	B2	3/2016	Neeser et al.	
4,724,659	A *	2/1988	Mori	9,315,283	B2	4/2016	Neeser et al.	
								B65B 13/32
								100/29
D295,525	S *	5/1988	Sakaki	9,745,090	B2 *	8/2017	Haberstroh	B65B 13/04
4,776,905	A	10/1988	Cheung et al.	9,932,135	B2	4/2018	Finzo et al.	
D307,435	S *	4/1990	Sakaki	2002/0100146	A1	8/2002	Ko	
D308,977	S *	7/1990	Sakaki	2002/0129717	A1	9/2002	Helland et al.	
5,133,532	A	7/1992	Figiel et al.	2002/0134811	A1	9/2002	Napier et al.	
5,146,847	A	9/1992	Lyon et al.	2003/0010223	A1 *	1/2003	Lopez	B65B 13/06
5,155,982	A	10/1992	Boek et al.					100/4
5,159,218	A	10/1992	Murry et al.	2003/0024217	A1 *	2/2003	Schwede	B65B 25/14
5,267,508	A *	12/1993	Yoshino					53/586
								B65B 13/32
								100/26
5,379,576	A	1/1995	Koyama et al.	2003/0145900	A1	8/2003	Jensen et al.	
5,516,022	A	5/1996	Annis, Jr.	2004/0206251	A1	10/2004	Nix	
5,651,306	A *	7/1997	Hoshino	2004/0237806	A1 *	12/2004	Sickels	B65B 13/06
								100/26
5,689,943	A	11/1997	Wehr	2004/0244605	A1 *	12/2004	Pearson	B65B 13/06
5,690,023	A	11/1997	Stamm et al.					100/8
5,798,596	A	8/1998	Lordo	2004/0255562	A1 *	12/2004	Haberstroh	B65B 13/06
5,809,873	A *	9/1998	Chak					53/589
								B65B 13/06
								100/26
5,944,064	A	8/1999	Saito et al.	2004/0255797	A1 *	12/2004	Bobren	B65B 13/06
6,003,578	A	12/1999	Chang					100/26
D424,078	S *	5/2000	Chin-Chang	2005/0279198	A1	12/2005	Kushida et al.	
6,109,325	A	8/2000	Chang	2006/0108180	A1	5/2006	Grach et al.	
6,308,760	B1	10/2001	Finzo et al.	2006/0192527	A1	8/2006	Kageler et al.	
6,332,306	B1	12/2001	Finzo et al.	2007/0163452	A1 *	7/2007	Bobren	B65B 13/06
6,367,732	B1 *	4/2002	Bobren					100/26
								B65B 13/184
								242/535.3
6,405,766	B1	6/2002	Benjey	2008/0072539	A1 *	3/2008	Morrison	B65B 13/06
6,463,721	B1 *	10/2002	Su					53/399
								B65B 13/22
								100/29
6,516,715	B1	2/2003	Reiche	2009/0013656	A1	1/2009	Nasiatka et al.	
6,568,159	B2 *	5/2003	Kawai	2009/0114308	A1	5/2009	Marelin et al.	
								B65B 13/04
								100/25
6,578,337	B2	6/2003	Scholl et al.	2011/0056389	A1	3/2011	Neeser et al.	
6,606,766	B2	8/2003	Ko	2011/0056390	A1	3/2011	Neeser et al.	
6,644,713	B2	11/2003	Del Pozo Abejon et al.	2011/0056391	A1	3/2011	Neeser et al.	
D488,822	S *	4/2004	Shibazaki	2011/0056392	A1	3/2011	Neeser et al.	
6,715,375	B2	4/2004	Nestler	2011/0100233	A1	5/2011	Neeser et al.	
6,729,357	B2	5/2004	Marsche	2011/0146505	A1 *	6/2011	Schwede	B65B 13/185
6,732,638	B1	5/2004	Rometty et al.					100/8
6,745,678	B1 *	6/2004	Liu	2011/0253480	A1	10/2011	Goodman et al.	
								B65B 13/06
								100/26
6,789,469	B1 *	9/2004	Tipton	2012/0017780	A1	1/2012	Haberstroh et al.	
								B65B 27/08
								100/18
6,817,159	B2	11/2004	Sakaki et al.	2012/0160364	A1	6/2012	Katou et al.	
6,820,402	B1 *	11/2004	Haberstroh	2012/0210682	A1	8/2012	Gardner	
								B65B 13/06
								100/8
6,918,235	B2	7/2005	Nix	2012/0216688	A1 *	8/2012	Liu	B65B 13/06
6,931,986	B1 *	8/2005	Liu					100/8
								B65B 13/22
								100/32
6,994,019	B1 *	2/2006	Liu	2013/0014653	A1 *	1/2013	Lai	B65B 13/06
								100/32
								B65B 13/08
								100/26
7,011,000	B2	3/2006	Kushida et al.	2013/0098252	A1 *	4/2013	Haberstroh	B65B 13/18
7,073,431	B1	7/2006	Chen					100/8
D546,852	S *	7/2007	Shimajima	2013/0276415	A1 *	10/2013	Haberstroh	B65B 13/04
7,240,612	B1 *	7/2007	Kirar					53/589
								B65B 13/06
								100/18
7,249,862	B2	7/2007	Shirane	2014/0083310	A1 *	3/2014	Hohn	B65B 13/18
								100/2
				2014/0290179	A1	10/2014	Keller	

(56)

References Cited

U.S. PATENT DOCUMENTS

2015/0210411 A1 7/2015 Finzo et al.  
2016/0107775 A1 4/2016 Amacker et al.

FOREIGN PATENT DOCUMENTS

CN 1151129 6/1997  
CN 2266566 11/1997  
CN 1203878 1/1999  
CN 1253099 5/2000  
CN 3260241 D 10/2002  
CN 1418163 5/2003  
CN 1558842 12/2004  
CN 1660675 8/2005  
CN 3534469 D 6/2006  
CN 1859999 11/2006  
CN 101134308 3/2008  
CN 101164416 4/2008  
CN 101287578 10/2008  
CN 101486329 7/2009  
CN 301044699 D 10/2009  
CN 201411061 2/2010  
CN 101678903 3/2010  
CN 301199818 S 5/2010  
CN 101870367 10/2010  
CN 301492534 S 3/2011  
CN 102026873 4/2011  
CN 102026874 4/2011  
CN 102026875 4/2011  
CN 202100012 1/2012  
CN 302836585 S 6/2014  
CN 303949899 S 11/2016  
CN 303979302 S 12/2016  
DE 39 16 355 12/1989  
DE 40 14 305 11/1991  
DE 19751861 1/1999  
DE 10026200 11/2001  
DE 20321137 1/2006  
DE 10 2005 049130 4/2007  
DE 10 2006 007990 8/2007  
DE 10 2009 047443 6/2011  
DE 202011050797 11/2011  
EP 0095643 12/1983  
EP 0480627 4/1992  
EP 0603868 6/1994  
EP 0659525 6/1995  
EP 0744343 11/1996  
EP 0949146 10/1999  
EP 0997377 5/2000  
EP 0999133 5/2000  
EP 1177978 2/2002  
EP 1316506 6/2003  
EP 1413519 4/2004  
EP 1837279 A1 9/2007  
EP 2271553 4/2013  
GB 1 161 827 8/1969  
GB 2 041 869 9/1980  
GB 2 481 724 1/2012  
JP S5290398 7/1977  
JP S541238 1/1979  
JP S5638220 4/1981  
JP S6322320 1/1988  
JP H05198241 8/1993  
JP H07300108 11/1995  
JP H08258808 10/1996

JP H08324506 12/1996  
JP H09283103 10/1997  
JP 3044132 5/2000  
JP 2000128113 5/2000  
JP 2000128115 5/2000  
JP 3227693 11/2001  
JP 3242081 12/2001  
JP 2002235830 8/2002  
JP 2003170906 6/2003  
JP 2003231291 8/2003  
JP 2003348899 12/2003  
JP 2004108593 4/2004  
JP 3548622 7/2004  
JP 2004241150 8/2004  
JP 2004323111 11/2004  
JP 2007276042 10/2007  
JP 4406016 1/2010  
KR 840002211 12/1984  
KR 20000029337 5/2000  
RU 1772784 10/1992  
RU 2118277 8/1998  
RU 2161773 1/2001  
RU 2004115639 1/2006  
RU 2355821 5/2009  
SU 1134117 1/1985  
WO WO 01/89929 11/2001  
WO WO 2006/048738 5/2006  
WO WO 2007/116914 10/2007  
WO WO 2009/129633 10/2009  
WO WO 2009/129636 10/2009

OTHER PUBLICATIONS

Brushless DC Motor Drives, By Ali Emandi, in Energy-Efficient Electrical Motors, 3rd ed., Aug. 2004, ¶. 270-272, CRC Press & Marcel Dekker.  
Lithium ion technology: shaping power tool. By Bender, in Air conditioning, heating, and refrigeration news. vol. 228, Issue 14, p. 18 Jul. 31, 2006.  
Orgapack GmbH, "OR-T 100, Battery-Hand Tool For Plastic Strapping" Operating and Safety Instructions (53 pages) Nov. 1, 2004.  
Orgapack GmbH, "OR-T 120, Battery-Operated Hand Tool For Plastic Strapping" Operating Instructions (36 Pages) Sep. 1, 2012.  
Orgapack GmbH, "OR-T 200, Battery-Hand Tool For Plastic Strapping" Operating and Safety Instructions (53 pages) Feb. 1, 2004.  
Orgapack GmbH, "OR-T 250, Battery-Hand Tool For Plastic Strapping" Operating Instructions (36 pages) Sep. 1, 2009.  
Orgapack GmbH, "OR-T 300, Battery-Hand Tool For Plastic Strapping" Operating and Safety Instructions (53 pages) Mar. 1, 2005.  
Orgapack GmbH, "OR-T 400, Battery-Hand Tool For Plastic Strapping" Operating Instructions (19 pages) Sep. 1, 2009.  
Orgapack GmbH, "OR-T 50, Hand Tool for Plastic Strapping" Operating and Safety Instructions (53 pages) May 1, 2006.  
Orgapack GmbH, "OR-T 83, Hand Tool For Plastic Strapping" Operating Instructions (58 pages) Aug. 1, 2000.  
Orgapack GmbH, "OR-T 85, Hand Tool for Plastic Strapping" Operating Instructions (58 pages) Jun. 1, 2000.  
Orgapack GmbH, "OR-T 86, Hand Tool For Plastic Strapping" Operating Instructions (58 pages) Aug. 1, 1999.  
Orgapack GmbH, "OR-T 87, Hand Tool For Plastic Strapping" Operating and Safety Instructions (63 pages) May 1, 2002.  
"Evaluation Report of Design Patent", CNIPA, from corresponding Chinese Design Patent No. 201730340255.7, dated Jul. 23, 2019.

\* cited by examiner



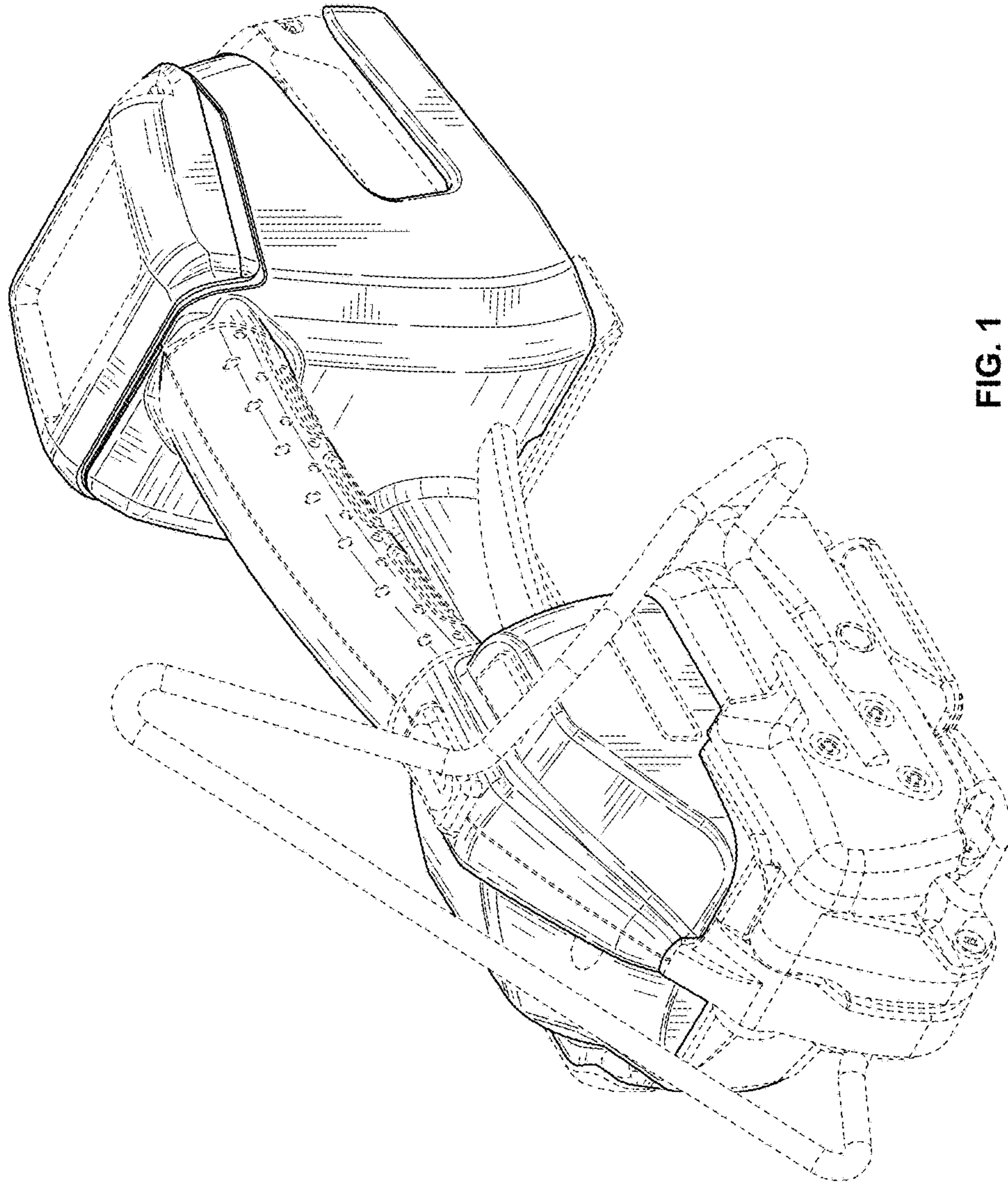

FIG. 1

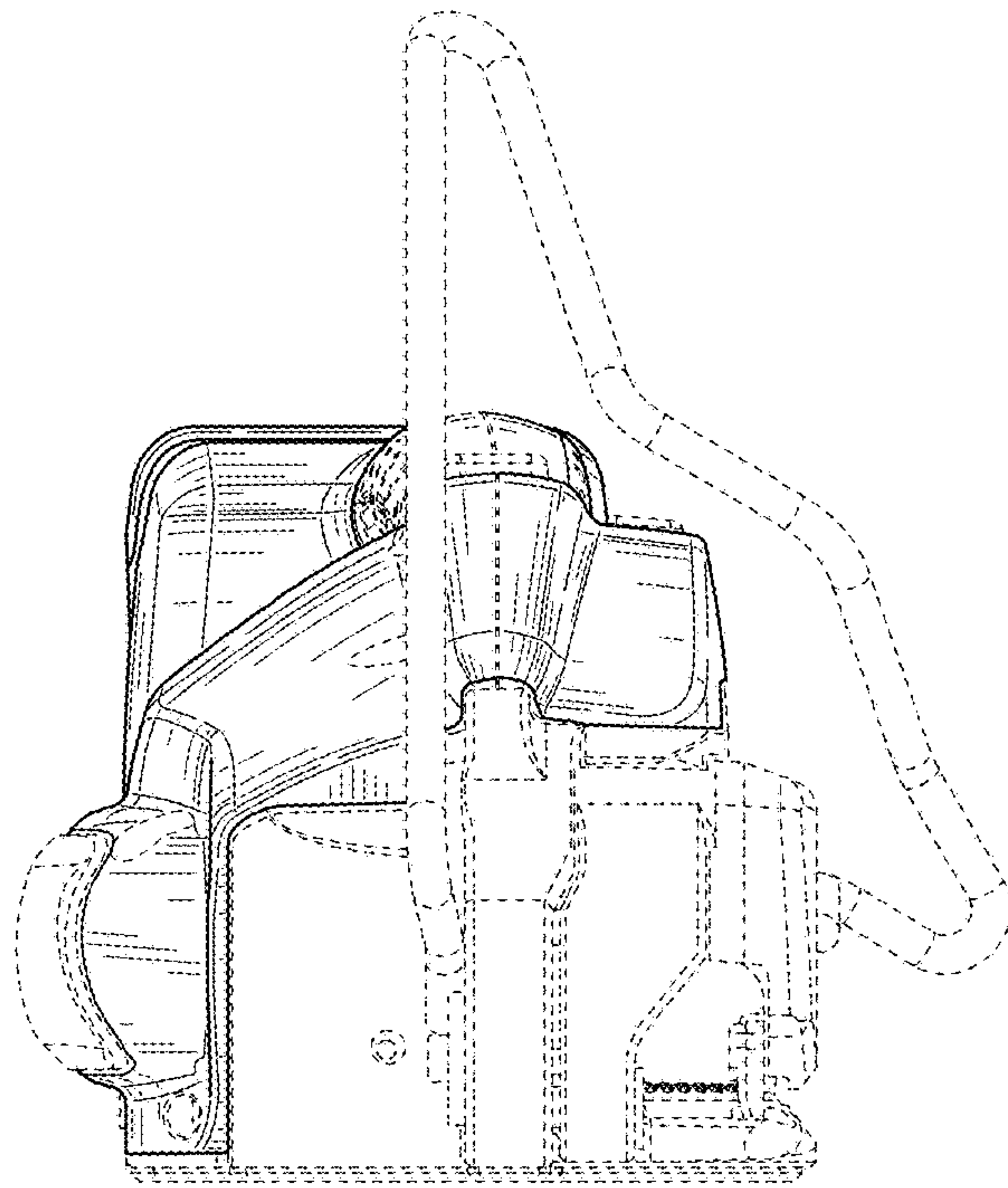

FIG. 2

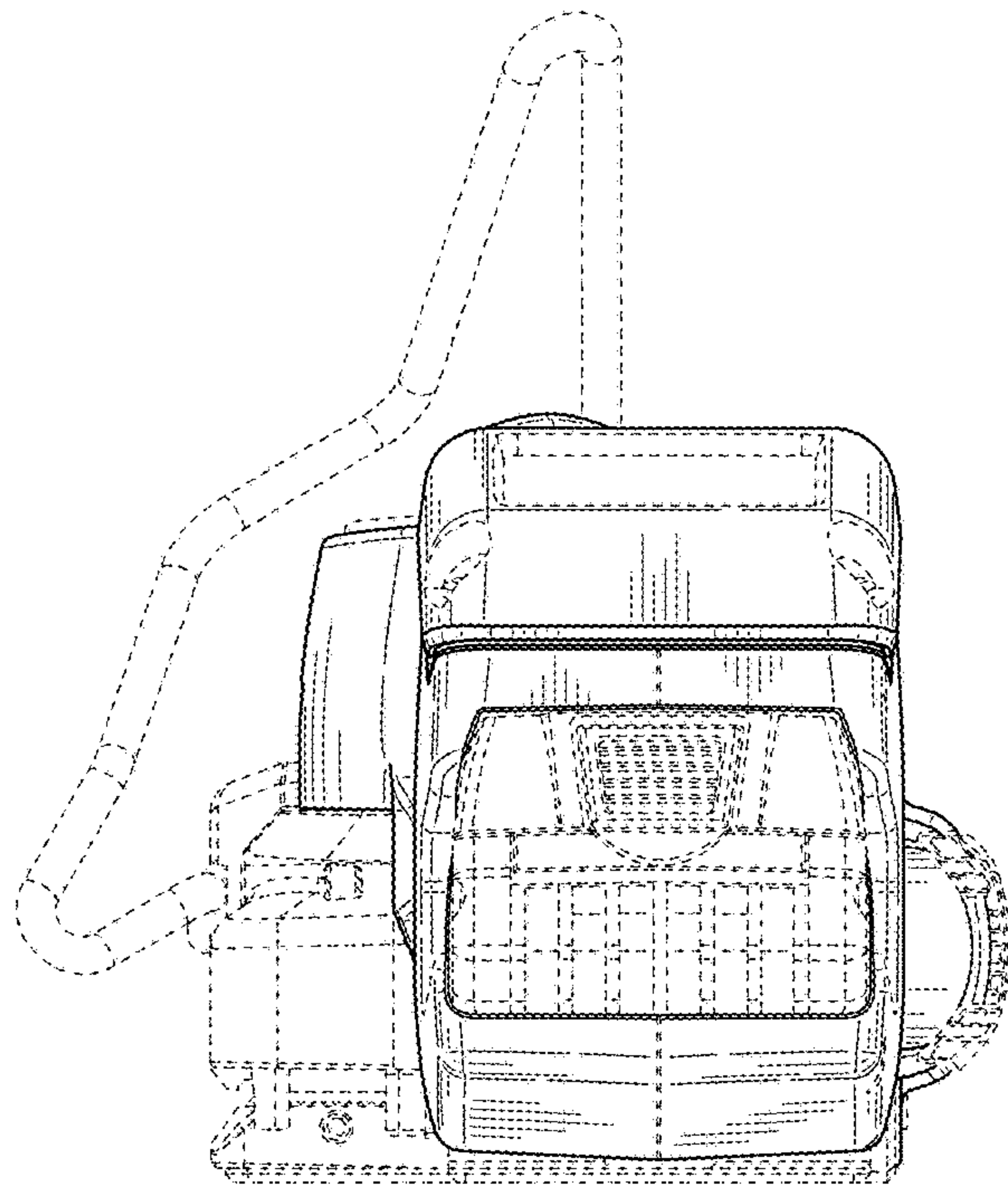

FIG. 3

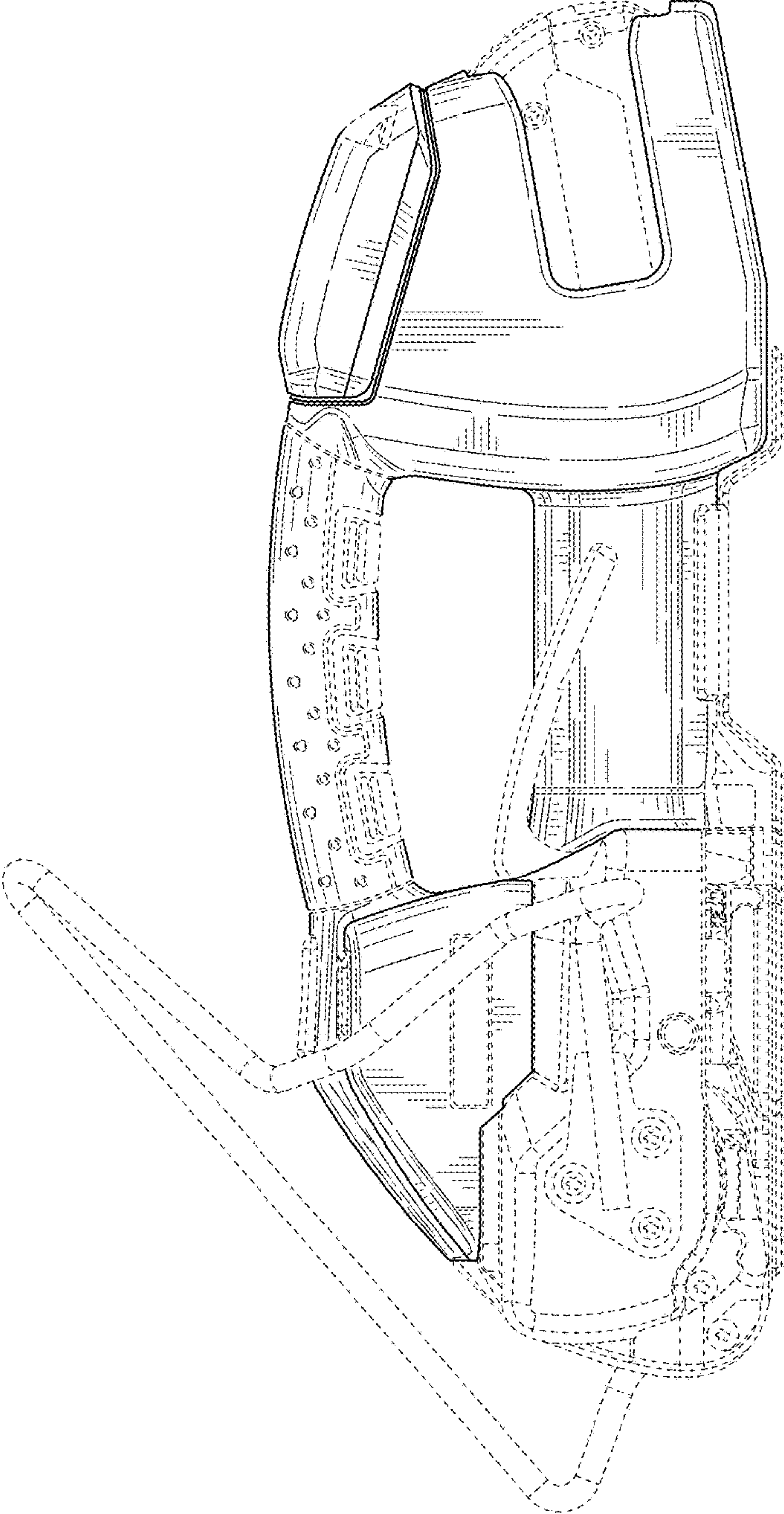

FIG. 4



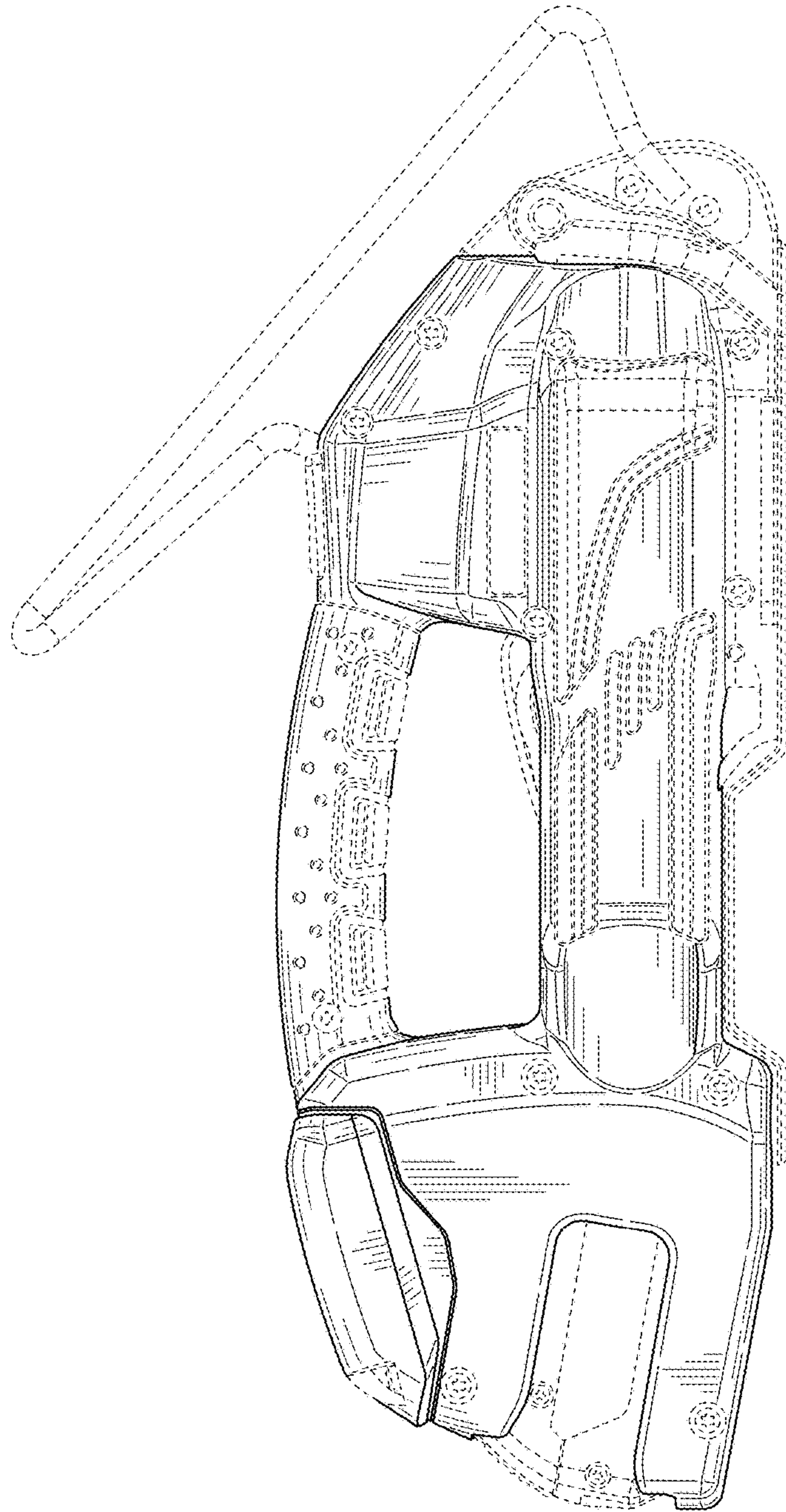

FIG. 5



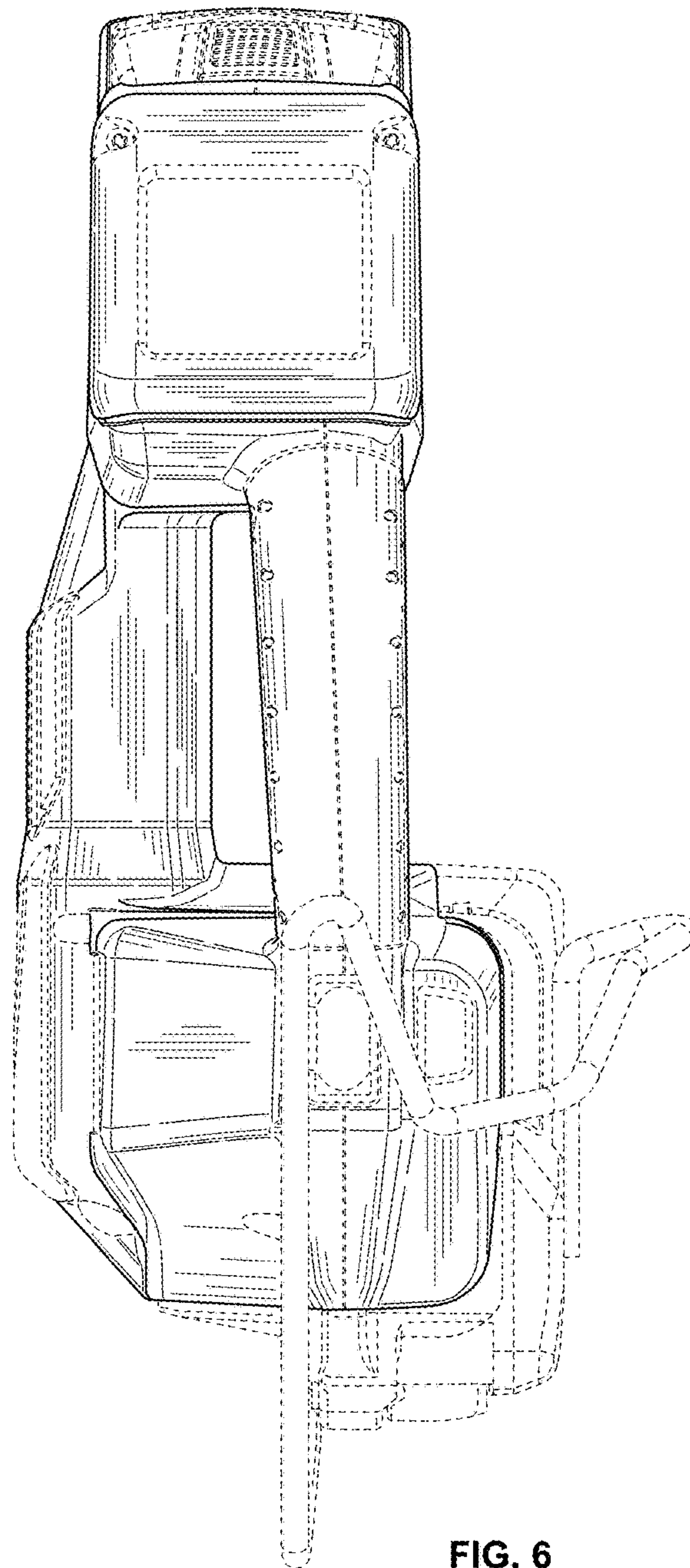

FIG. 6

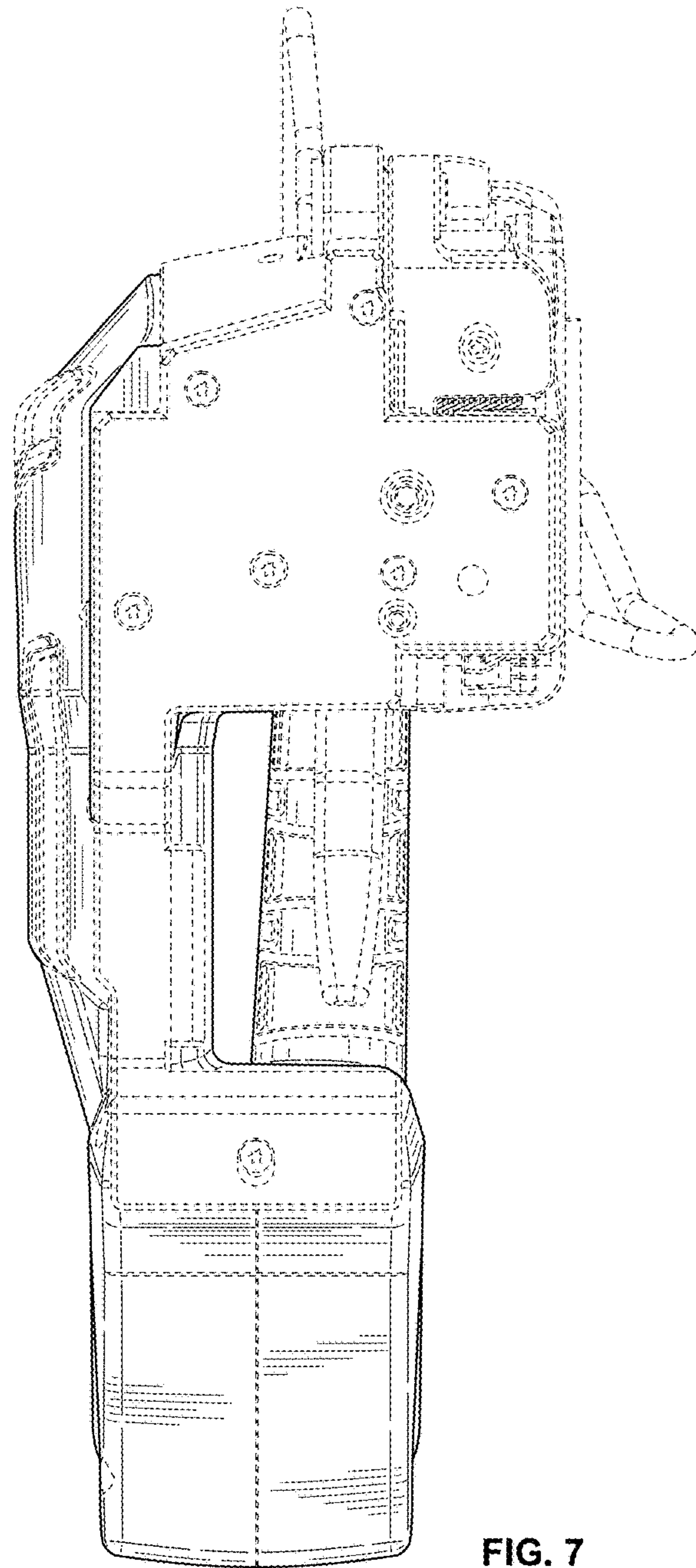

FIG. 7

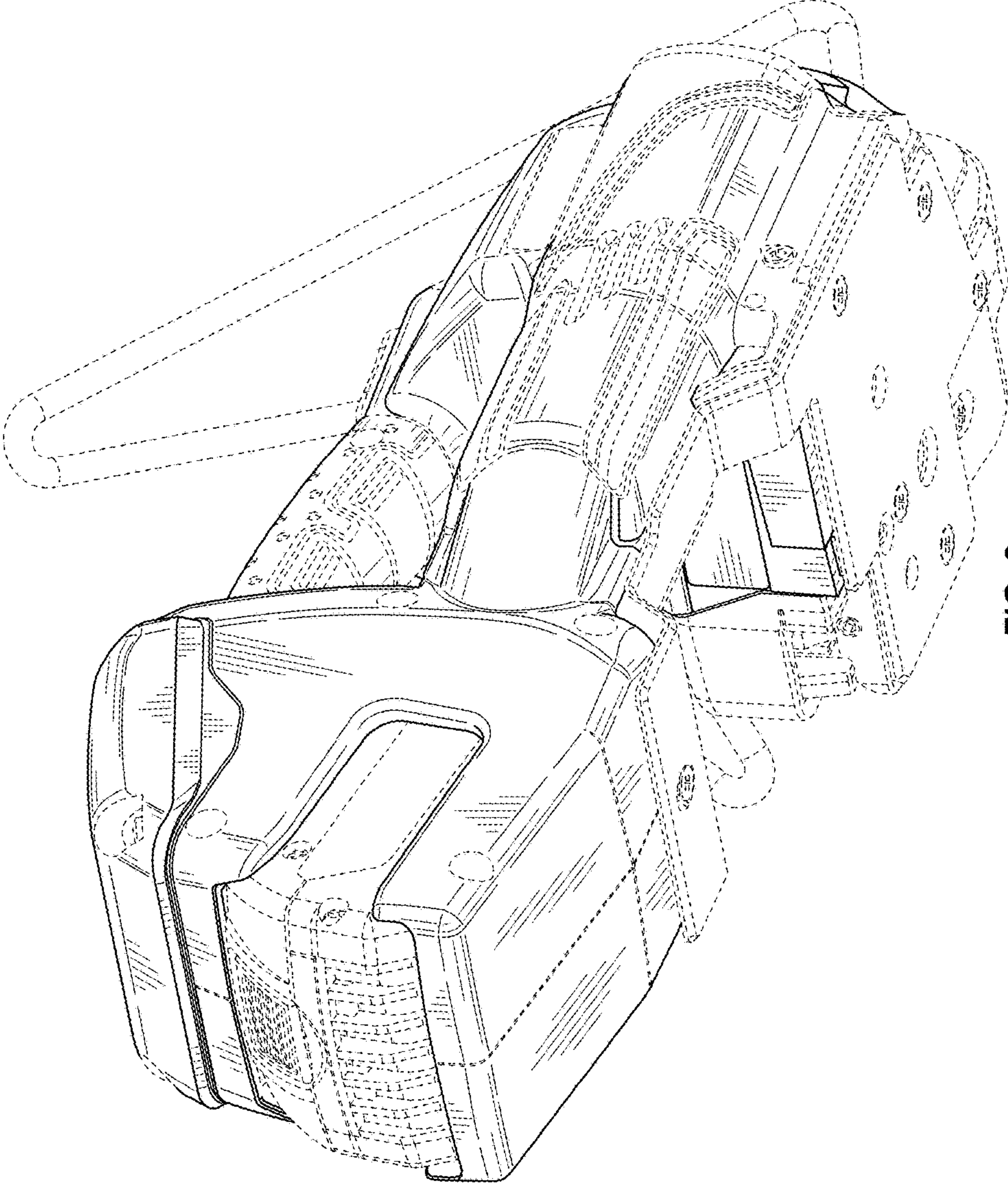

FIG. 8



UNITED STATES PATENT AND TRADEMARK OFFICE  
**CERTIFICATE OF CORRECTION**

PATENT NO. : D864,688 S  
APPLICATION NO. : 29/598733  
DATED : October 29, 2019  
INVENTOR(S) : Samuel Hochstrasser

Page 1 of 1

It is certified that error appears in the above-identified patent and that said Letters Patent is hereby corrected as shown below:

On the Title Page

Item (30) Foreign Application Priority Data:

Insert -- January 30, 2017 (DE) 402017200401.5 --

Signed and Sealed this  
Twentieth Day of July, 2021



Drew Hirshfeld  
*Performing the Functions and Duties of the  
Under Secretary of Commerce for Intellectual Property and  
Director of the United States Patent and Trademark Office*