

US00D864264S

(12) **United States Design Patent** (10) **Patent No.:** **US D864,264 S**  
**Tudor et al.** (45) **Date of Patent:** **\*\* Oct. 22, 2019**

(54) **FLUID BODY OF A DISPENSE VALVE**  
(71) Applicant: **NORDSON CORPORATION**,  
Westlake, OH (US)  
(72) Inventors: **Thomas R. Tudor**, Westland, MI (US);  
**William C. Paetow, II**, Pinckney, MI  
(US); **Jerry R. Routen**, Westland, MI  
(US)  
(73) Assignee: **Nordson Corporation**, Westlake, OH  
(US)  
(\*\*) Term: **15 Years**  
(21) Appl. No.: **29/624,112**  
(22) Filed: **Oct. 30, 2017**  
(51) **LOC (12) Cl.** ..... **15-09**  
(52) **U.S. Cl.**  
USPC ..... **D15/138**  
(58) **Field of Classification Search**  
USPC ..... D15/138, 144, 144.1, 144.2, 150, 151,  
D15/152; D23/213, 222-230  
CPC ..... B05B 11/306; B05B 11/3032  
See application file for complete search history.

D287,266 S \* 12/1986 Knetl ..... D23/226  
D290,993 S \* 7/1987 Clivio ..... D23/226  
4,708,292 A \* 11/1987 Gammons ..... B29B 7/7678  
239/414  
D293,127 S \* 12/1987 Hengesbach ..... D23/226  
D297,351 S \* 8/1988 Kitts ..... D23/226  
D301,366 S \* 5/1989 Fink, Jr. .... D23/226  
D308,094 S \* 5/1990 Hengesbach ..... D23/226  
D314,811 S \* 2/1991 Gammons ..... D23/226  
5,020,696 A \* 6/1991 Cater ..... B05B 11/3018  
222/321.2  
D318,316 S \* 7/1991 Hengesbach ..... D23/226  
D354,333 S \* 1/1995 Clivio ..... D23/223  
D354,545 S \* 1/1995 Haruch ..... D23/213  
D355,704 S \* 2/1995 Simpson ..... D23/223  
D385,010 S \* 10/1997 Hennessy ..... D23/213  
D390,630 S \* 2/1998 McKown ..... D23/213  
5,740,968 A \* 4/1998 Mueller ..... B05B 1/3046  
239/526

(Continued)

*Primary Examiner* — Patricia A Palasik  
(74) *Attorney, Agent, or Firm* — Baker & Hostetler LLP

(57) **CLAIM**

The ornamental design for a fluid body of a dispense valve,  
as shown and described.

**DESCRIPTION**

FIG. 1 is a top perspective view of a fluid body of a dispense  
valve.  
FIG. 2 is a left side view thereof;  
FIG. 3 is a right side view thereof;  
FIG. 4 is a top view thereof;  
FIG. 5 is a bottom view thereof;  
FIG. 6 is a front view thereof; and,  
FIG. 7 is a rear view thereof.  
The subject matter shown in dashed lines, and any surfaces  
of the design not shown, form no part of the claimed  
invention.

**1 Claim, 5 Drawing Sheets**

(56) **References Cited**  
U.S. PATENT DOCUMENTS  
D155,508 S \* 10/1949 Heimburger ..... D23/223  
2,659,628 A \* 11/1953 Beach ..... A23G 3/2092  
239/414  
3,001,723 A \* 9/1961 Bounds ..... B05B 1/308  
239/448  
3,670,967 A \* 6/1972 Fahlin ..... B05B 9/01  
239/412  
D259,733 S \* 6/1981 Tisserat ..... D23/226  
4,394,941 A \* 7/1983 Recine ..... A47G 19/34  
222/355  
4,534,512 A \* 8/1985 Chow ..... B05B 1/12  
239/394  
D284,301 S \* 6/1986 Hengesbach ..... D23/226

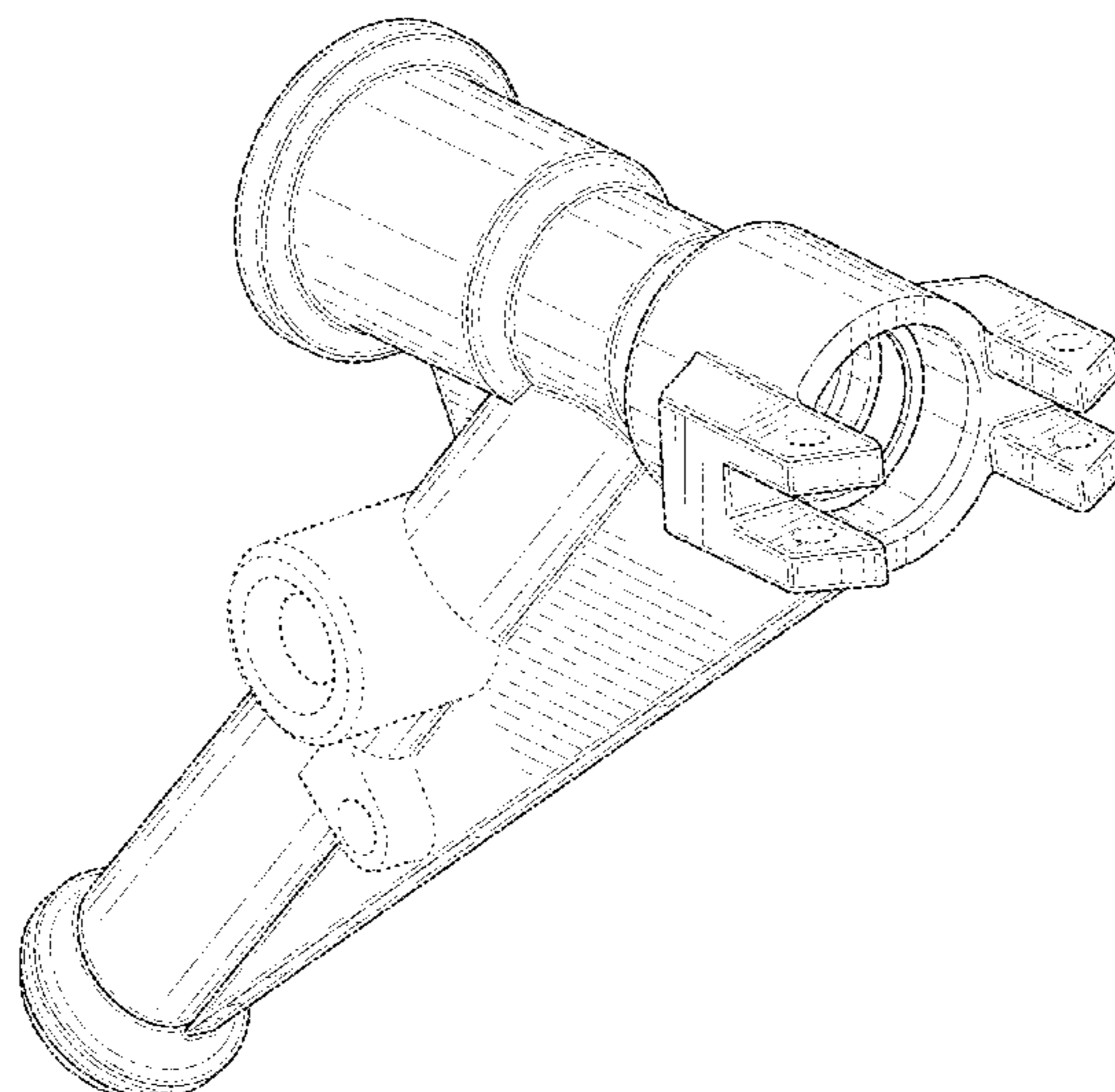

(56)

**References Cited**

U.S. PATENT DOCUMENTS

D396,995 S \* 8/1998 Miltenberger ..... D7/397  
D398,371 S \* 9/1998 Sundahl ..... D23/226  
D447,216 S \* 8/2001 Heren ..... D23/226  
D479,304 S \* 9/2003 Chen ..... D23/223  
7,163,130 B2 \* 1/2007 Lafond ..... B05C 17/00503  
222/326  
D542,376 S \* 5/2007 Blette ..... D23/213  
D623,264 S \* 9/2010 Parrott ..... D23/213  
D628,275 S \* 11/2010 Lammel ..... D23/238  
D648,417 S \* 11/2011 Varini ..... D23/226  
D650,047 S \* 12/2011 Varini ..... D23/226  
D659,536 S \* 5/2012 Bedford ..... D9/448  
8,240,513 B2 \* 8/2012 Voskuil ..... B01F 13/1058  
222/144  
D670,786 S \* 11/2012 Mauchle ..... D23/213  
D832,396 S \* 10/2018 Tabata ..... D23/213  
2017/0121069 A1 \* 5/2017 Clements ..... B65D 47/065

\* cited by examiner

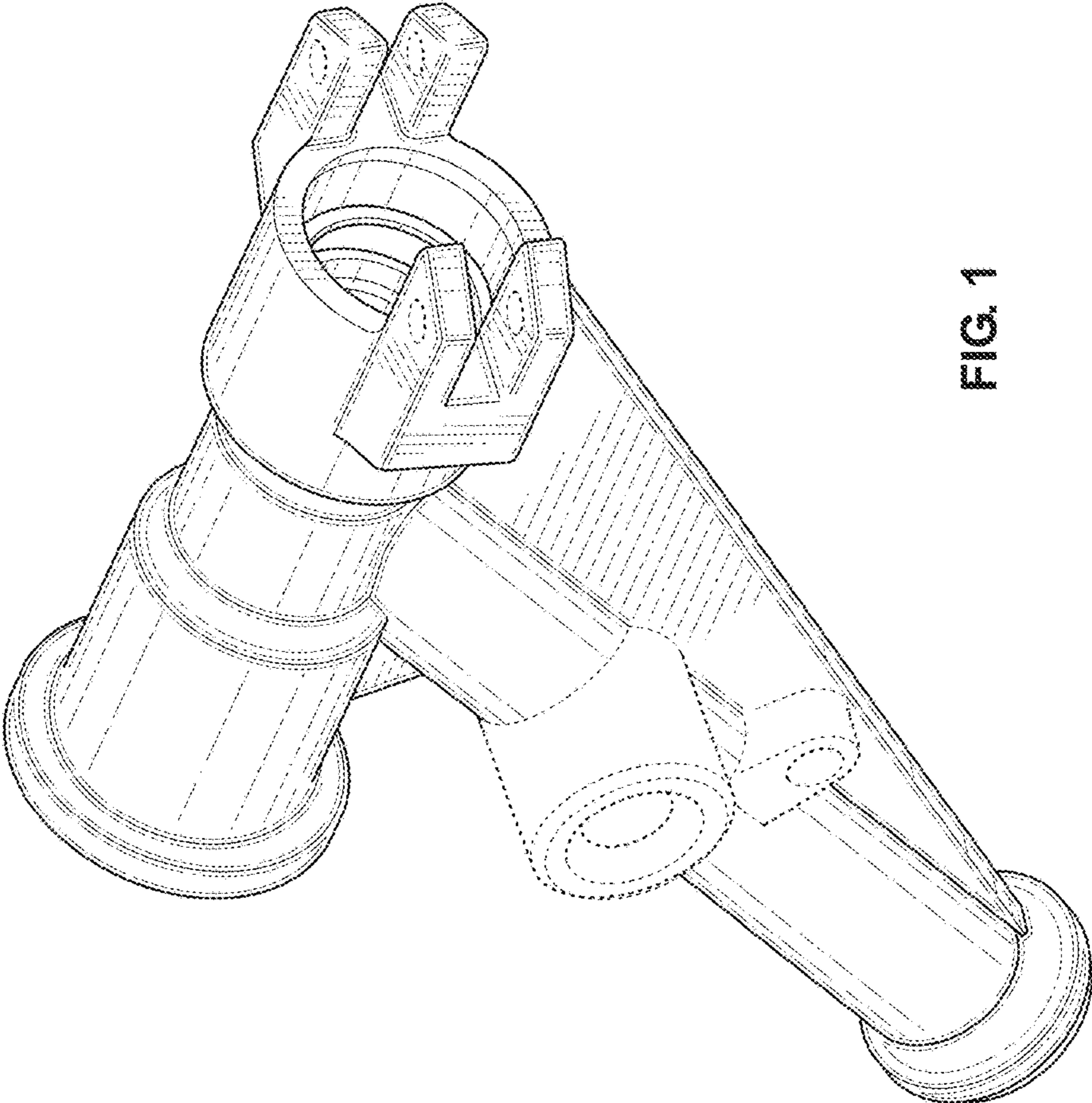

FIG. 1

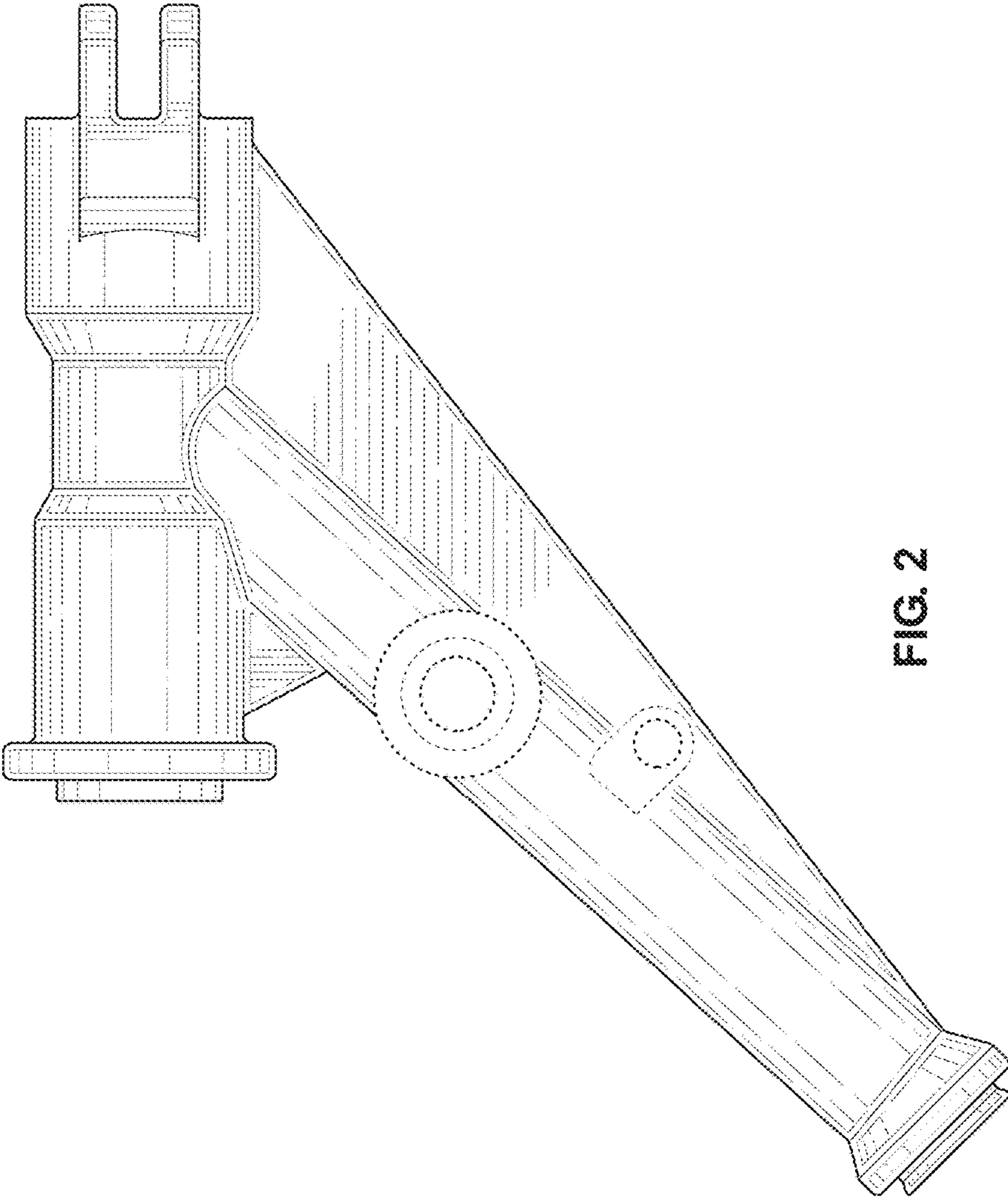

FIG. 2



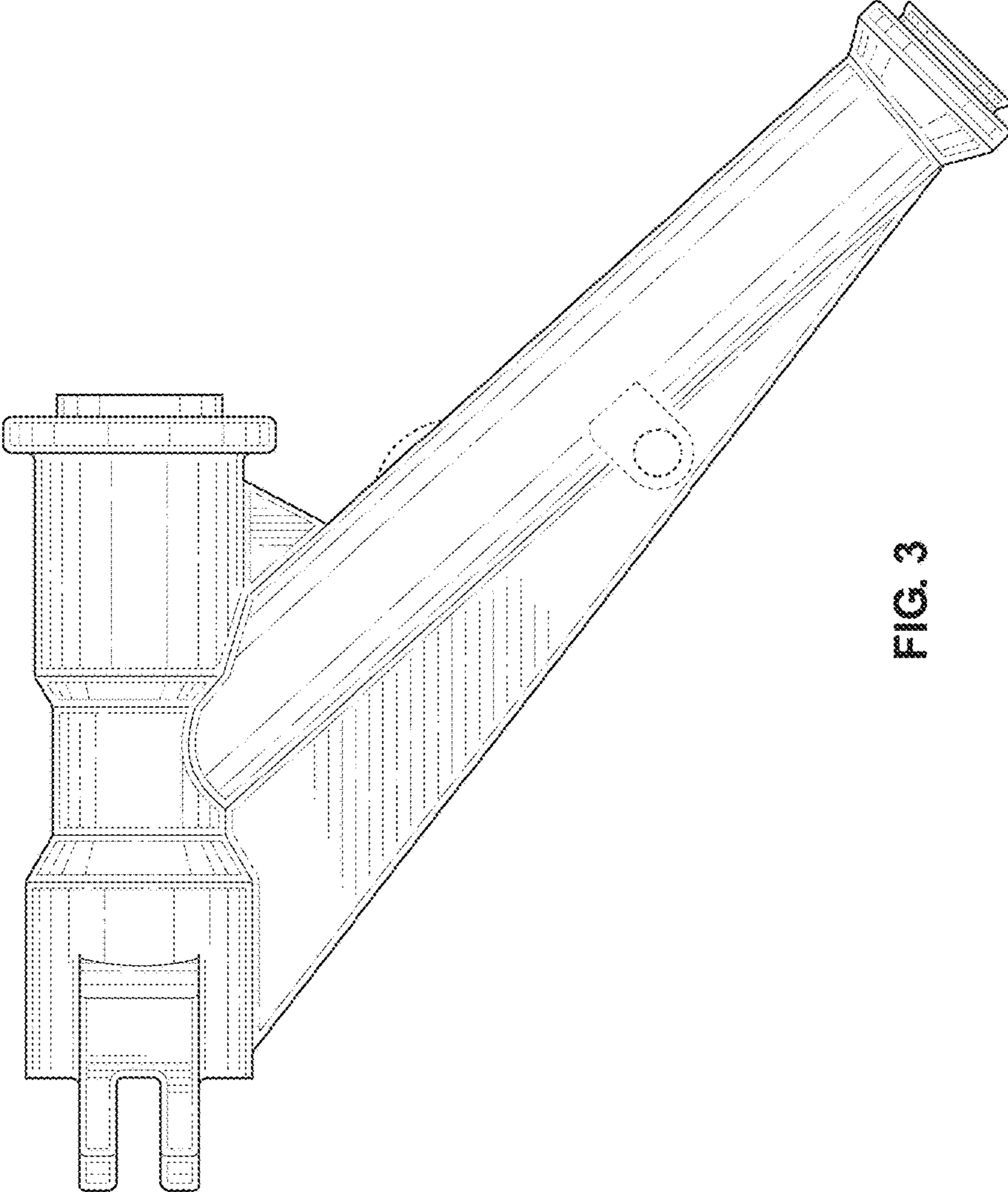

FIG. 3

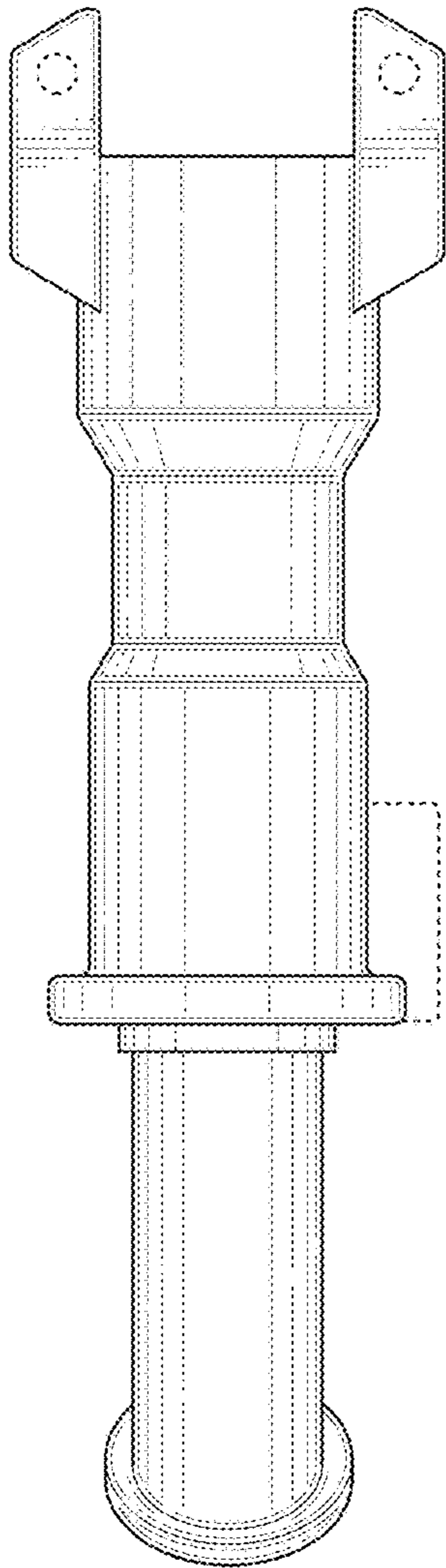

FIG. 4

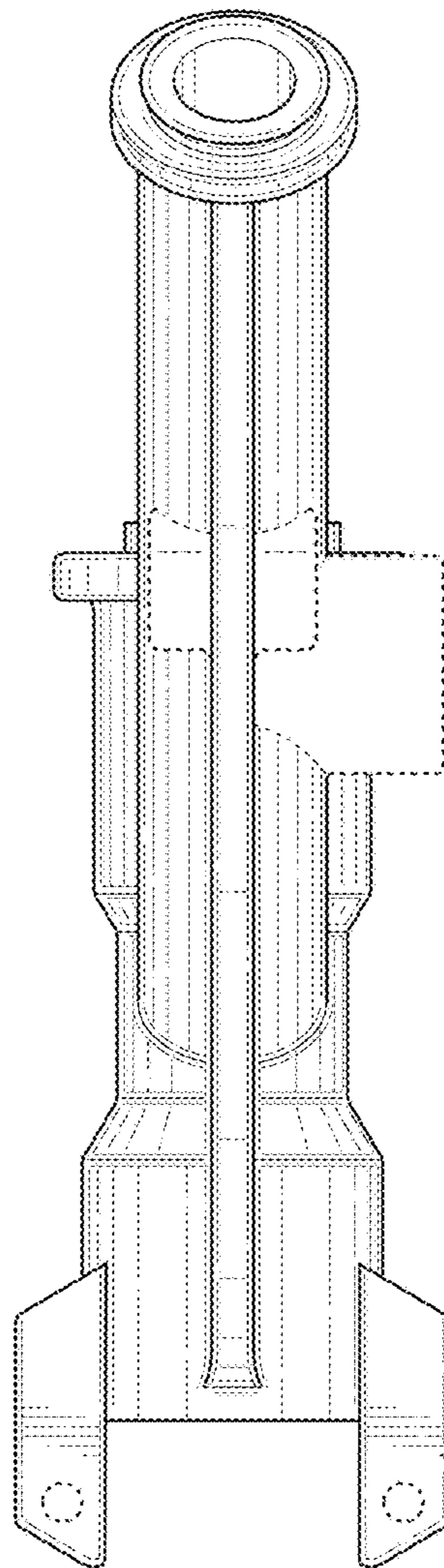

FIG. 5

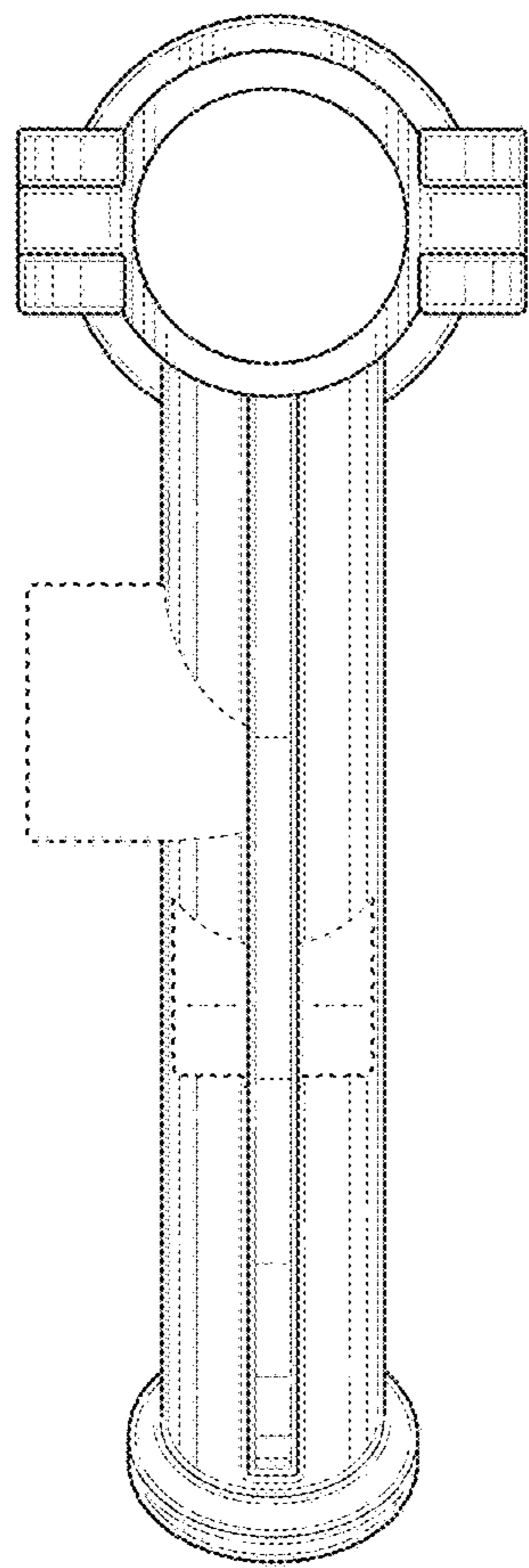

FIG. 6

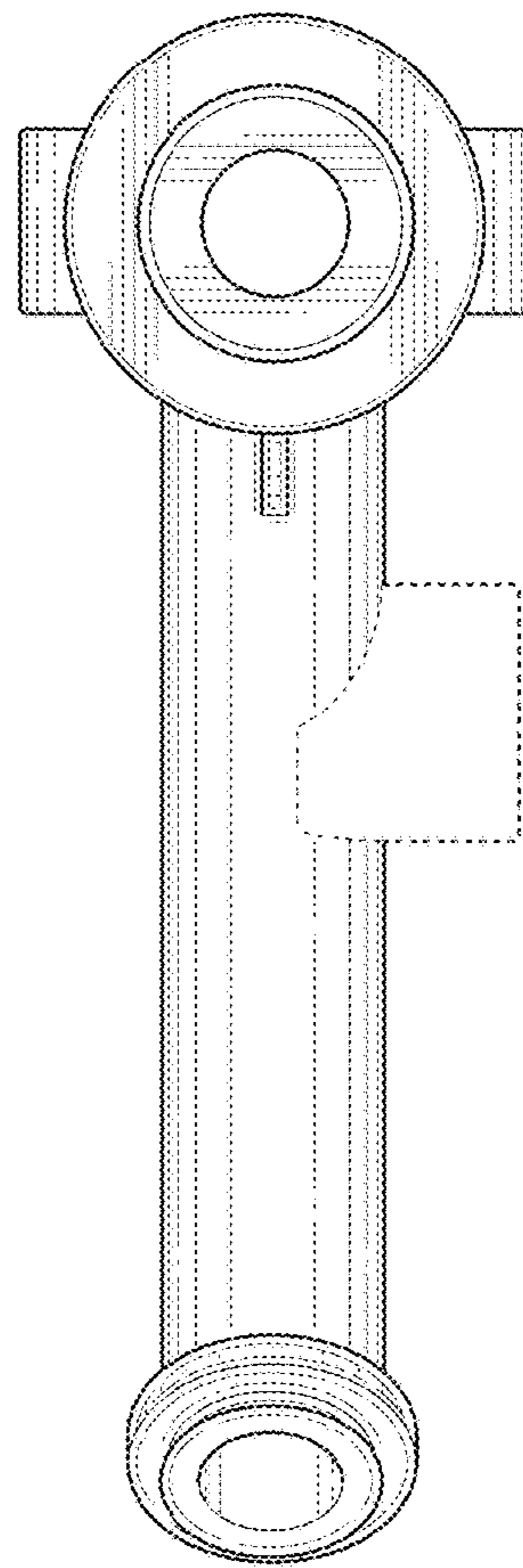

FIG. 7