



US00D864055S

(12) **United States Design Patent** (10) **Patent No.:** **US D864,055 S**
Chan et al. (45) **Date of Patent:** **** Oct. 22, 2019**

(54) **REAR BUMPER**
(71) Applicant: **Jaguar Land Rover Limited**, Whitley, Coventry (GB)
(72) Inventors: **Alex Chan**, Coventry (GB); **Paven Patel**, Coventry (GB)
(73) Assignee: **Jaguar Land Rover Limited**, Whitley, Coventry (GB)
(**) Term: **15 Years**

(21) Appl. No.: **29/629,401**
(22) Filed: **Dec. 13, 2017**

(30) **Foreign Application Priority Data**
Jun. 15, 2017 (EM) 004049054
(51) **LOC (12) Cl.** **12-16**
(52) **U.S. Cl.**
USPC **D12/169**
(58) **Field of Classification Search**
USPC D12/86, 90-92, 163, 164, 169, 171, 196, D12/216
CPC B60R 19/02; B60R 19/04; B62D 25/08
See application file for complete search history.

(56) **References Cited**
U.S. PATENT DOCUMENTS
D637,535 S * 5/2011 Yukawa D12/169
D793,927 S * 8/2017 Potter D12/169
D797,615 S * 9/2017 Hatton D12/169
D801,885 S * 11/2017 Melikian D12/169
D808,871 S * 1/2018 Peat D12/169
D814,985 S * 4/2018 Peat D12/169
D818,402 S * 5/2018 Kawakami D12/169
D820,175 S * 6/2018 Ishigaki D12/169
D824,816 S * 8/2018 Nakajima D12/169
D824,818 S * 8/2018 Morikawa D12/169

D825,409 S * 8/2018 Kayakabe D12/169
D825,413 S * 8/2018 Luk D12/169
D825,415 S * 8/2018 De Bono D12/169
(Continued)

OTHER PUBLICATIONS

<https://www.jaguar.com/jaguar-range/e-pace/index.html> Aug. 6, 2017 (Year: 2017).*

Primary Examiner — Leanne Was-Englehart
(74) *Attorney, Agent, or Firm* — Wood Herron & Evans LLP

(57) **CLAIM**
The ornamental design for a rear bumper, as shown and described.

DESCRIPTION

FIG. 1 is a front right perspective view of a rear bumper according to the present invention.
FIG. 2 is a front left perspective view of the rear bumper shown in FIG. 1.
FIG. 3 is a rear left perspective view thereof.
FIG. 4 is a rear right perspective view thereof.
FIG. 5 is a front view thereof.
FIG. 6 is a rear view thereof.
FIG. 7 is a right side view thereof.
FIG. 8 is a left side view thereof.
FIG. 9 is a top view thereof.
FIG. 10 is a bottom view thereof; and,
FIG. 11 is a front view of the rear bumper shown in FIGS. 1-10, but with the rear bumper mounted on a vehicle, and the rest of the vehicle shown in de-emphasized and half-tone portions so as to illustrate environmental structure. These portions form no part of the claimed invention. More particularly, in FIG. 11, the inventive rear bumper is shown within the broken line, and the elements shown outside the broken line form no part of the claimed invention, but are instead included to show environmental aspects thereof.

1 Claim, 11 Drawing Sheets

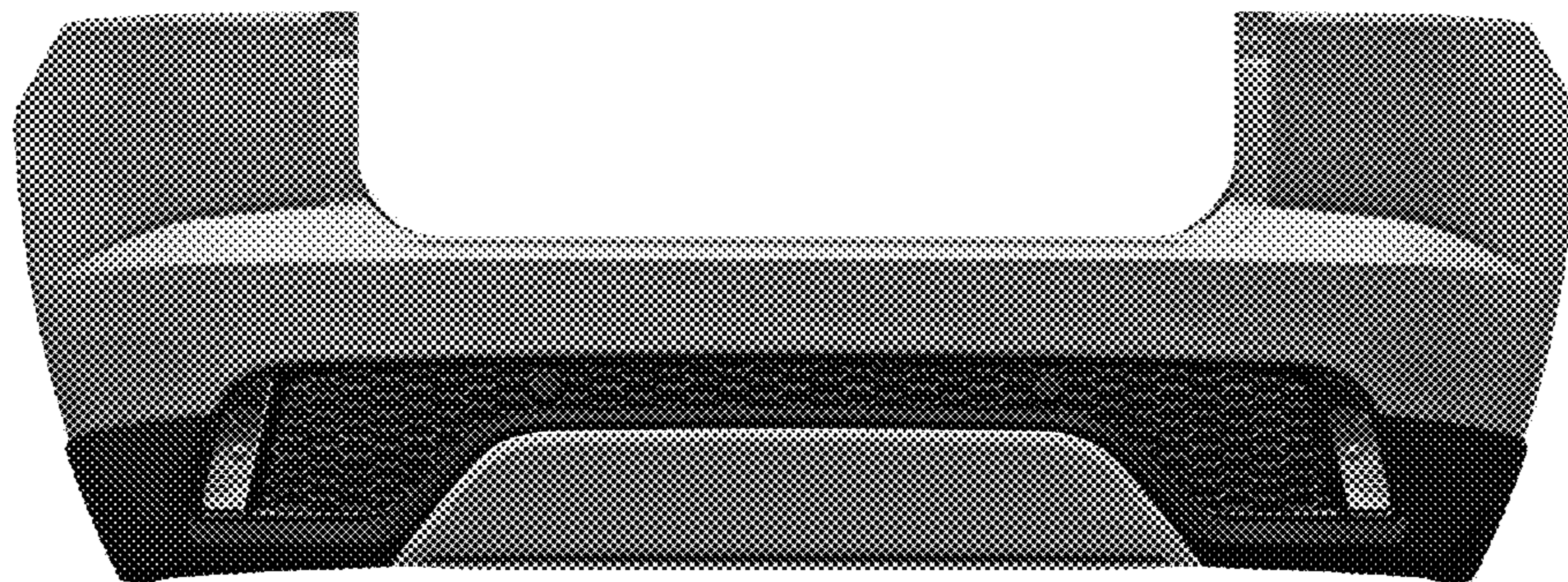

(56)

References Cited

U.S. PATENT DOCUMENTS

D827,517 S * 9/2018 Whang D12/169
D831,547 S * 10/2018 Granlund D12/163

* cited by examiner



FIG. 1

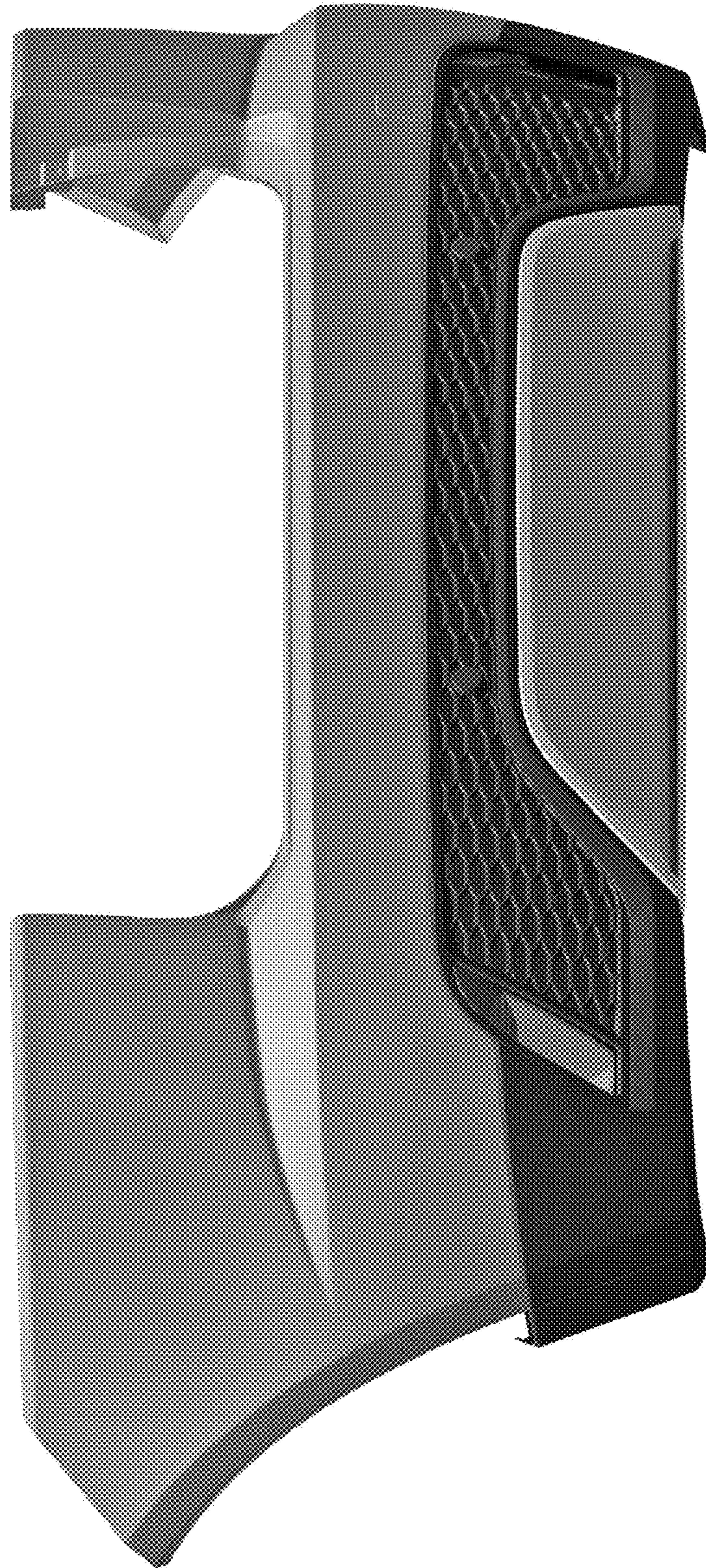

FIG. 2



FIG. 3



FIG. 4



FIG. 5

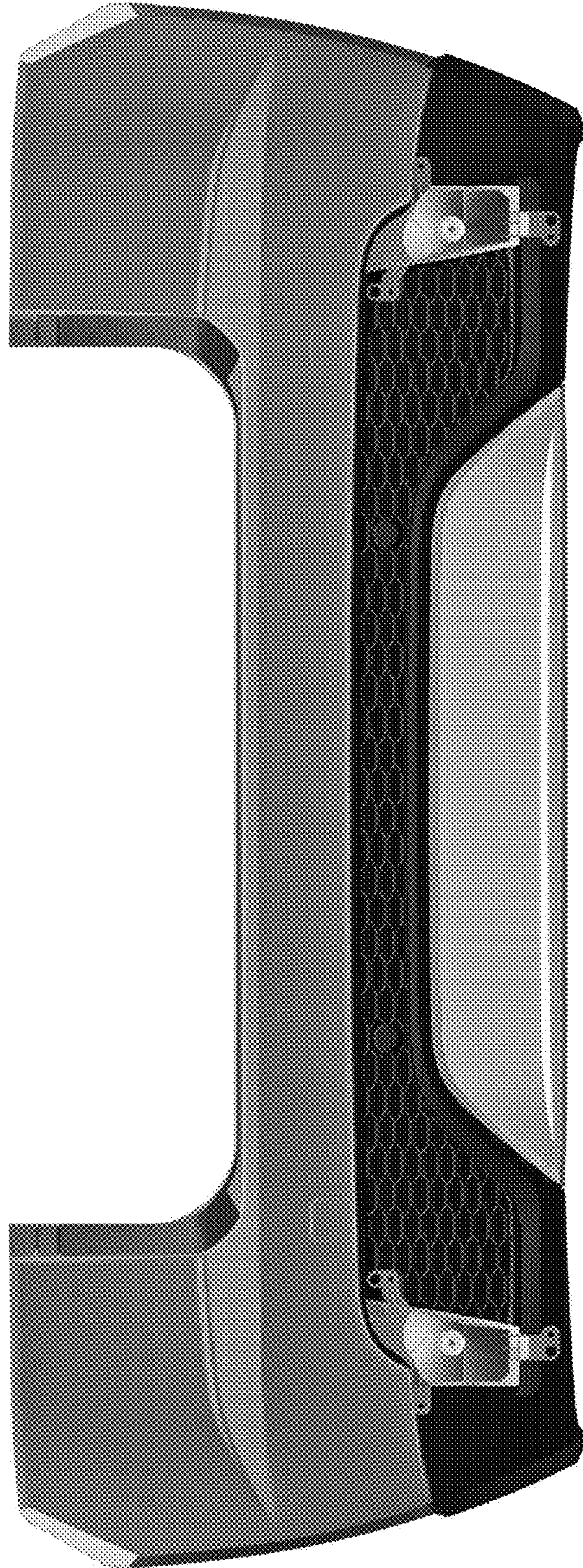

FIG. 6

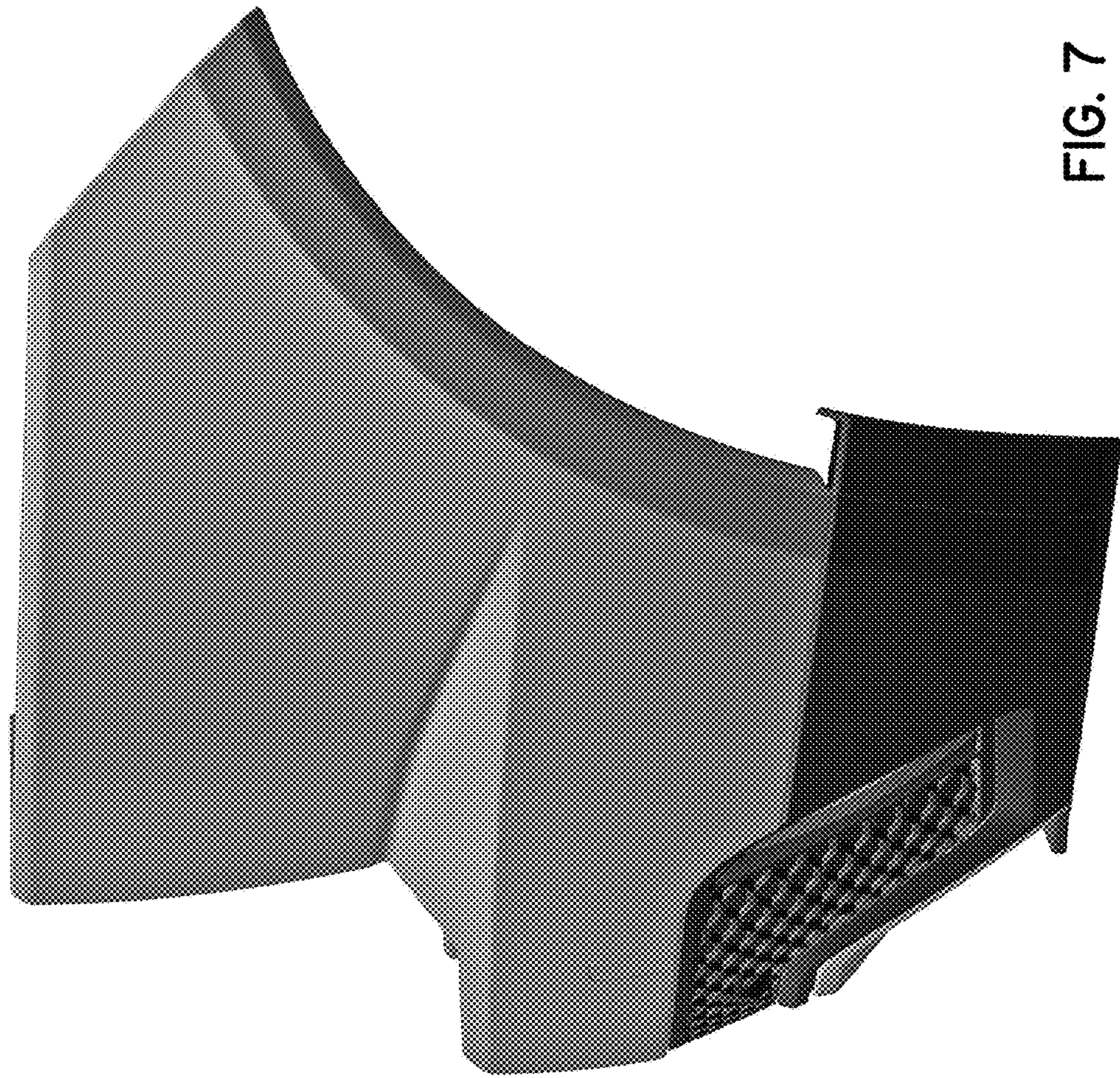

FIG. 7

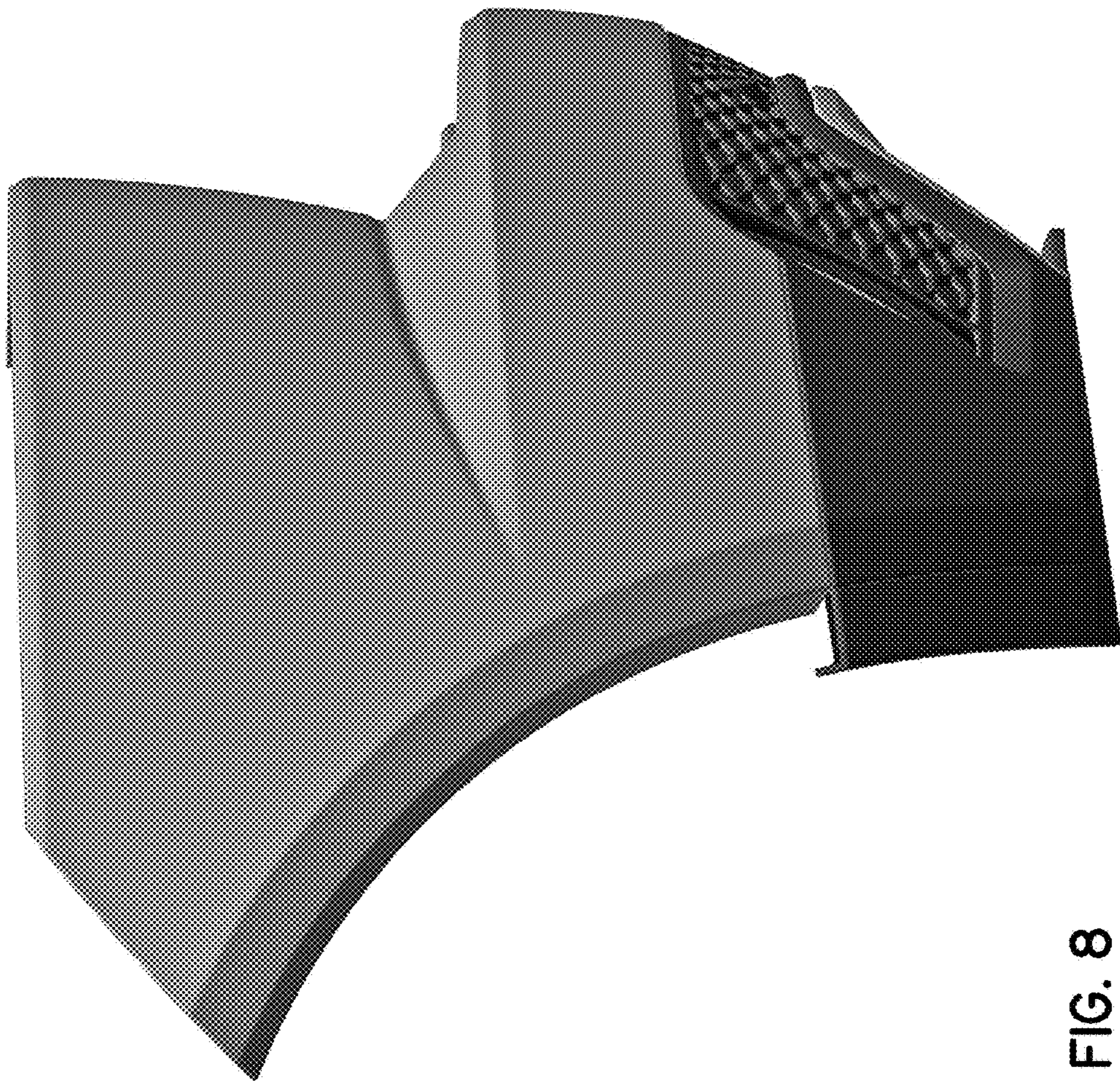

FIG. 8

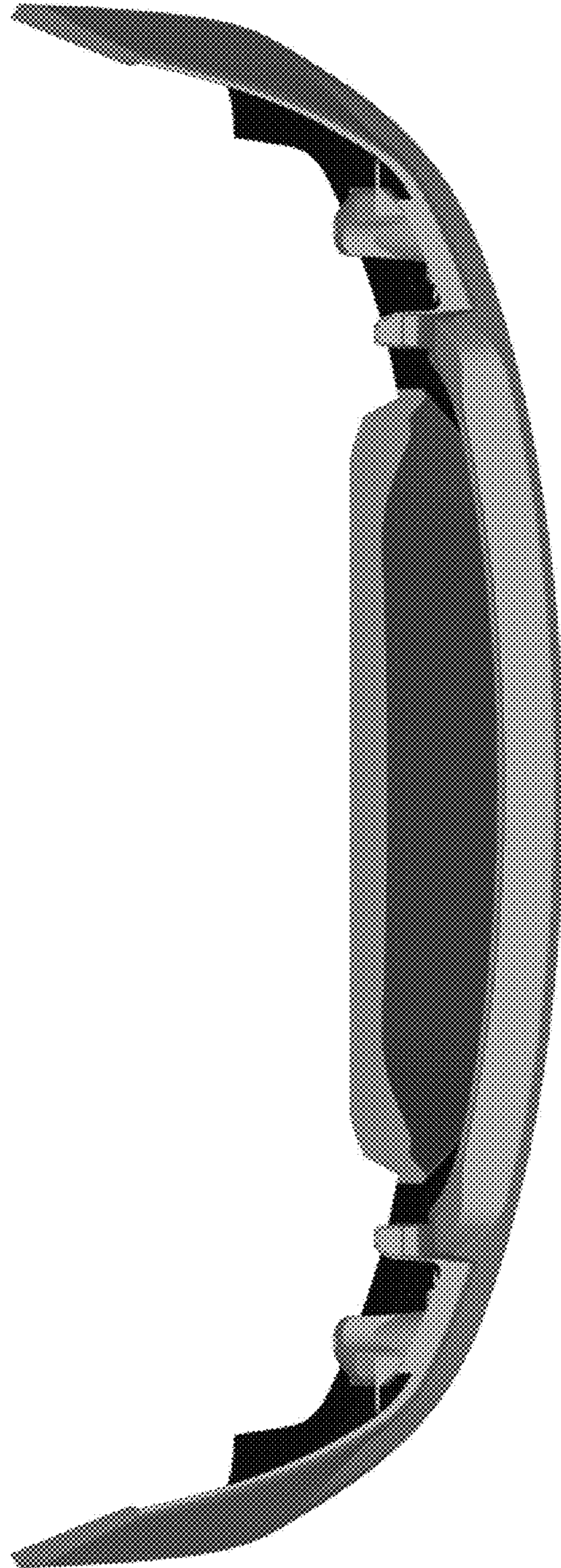

FIG. 9

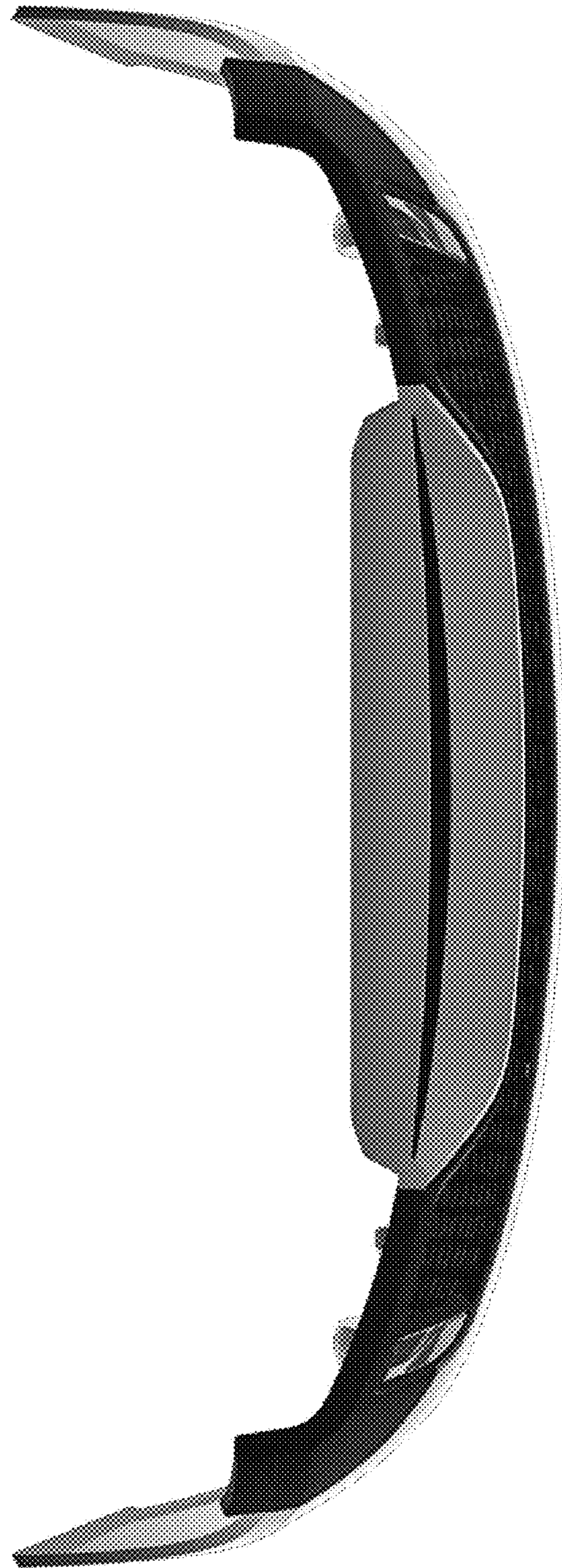

FIG. 10

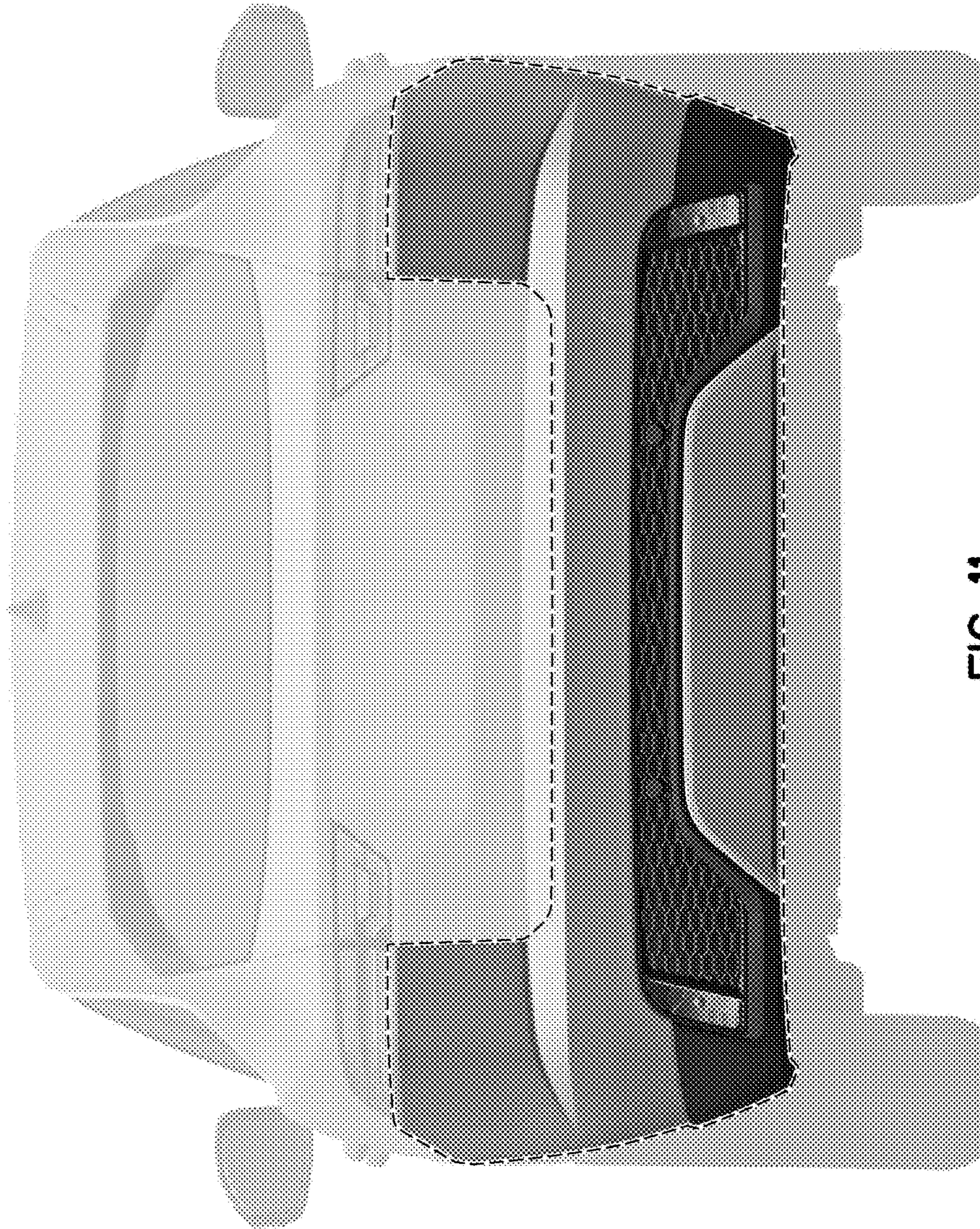

FIG. 11