

US00D862668S

(12) **United States Design Patent** (10) **Patent No.:** **US D862,668 S**
Moseley (45) **Date of Patent:** **** Oct. 8, 2019**

- (54) **AIR SHROUD ASSEMBLY**
- (71) Applicant: **DOMETIC SWEDEN AB**, Solna (SE)
- (72) Inventor: **Andrew Moseley**, Herborn (DE)
- (73) Assignee: **Dometic Sweden AB**, Solna (ES)
- (**) Term: **15 Years**
- (21) Appl. No.: **29/620,395**
- (22) Filed: **Oct. 4, 2017**

3,848,428 A 11/1974 Rieter, Jr.
 3,867,486 A 2/1975 Nagele
 3,885,398 A 5/1975 Dawkins
 (Continued)

FOREIGN PATENT DOCUMENTS

AU 3067405 3/2016
 AU 201612249 5/2016
 (Continued)

OTHER PUBLICATIONS

Transmittal Letter of Related Cases.
 (Continued)

Related U.S. Application Data

- (62) Division of application No. 29/552,019, filed on Jan. 19, 2016, now Pat. No. Des. 817,466.
- (51) **LOC (12) Cl.** **12-16**
- (52) **U.S. Cl.**
USPC **D23/325**
- (58) **Field of Classification Search**
USPC D23/325, 342, 314, 318, 324; D6/432,
D6/472; D10/49, 50
CPC B60H 1/3232; B60H 1/262; B60H 1/246;
B60H 1/26; B60H 1/00364; B60H
1/00535; B60P 3/20; F25D 23/00
See application file for complete search history.

Primary Examiner — T Chase Nelson
Assistant Examiner — Ania Aman
 (74) *Attorney, Agent, or Firm* — Middleton Reutlinger

(57) **CLAIM**

The ornamental design for an air shroud assembly, as shown and described.

DESCRIPTION

Cross-reference is made to U.S. Non-Provisional patent application Ser. No. 15/407,709 titled, "Parking Cooler" filed Jan. 17, 2017, which is expressly incorporated by reference herein.

FIG. 1 is a front perspective view of an air shroud assembly showing my new design;

FIG. 2 is a front elevation view of the design of FIG. 1;

FIG. 3 is a rear elevation view of the design of FIG. 1;

FIG. 4 is a first side elevation view of the design of FIG. 1;

FIG. 5 is a second side elevation view of the design of FIG. 1;

FIG. 6 is a top plan view of the design of FIG. 1; and,

FIG. 7 is a bottom plan view of the design of FIG. 1.

The broken line disclosure represents unclaimed portions of the air shroud assembly in which the design is embodied.

1 Claim, 7 Drawing Sheets

(56) **References Cited**

U.S. PATENT DOCUMENTS

964,146 A	7/1910	Clark
RE24,637 E	4/1959	Wulle
3,092,009 A	6/1963	Goettl
3,115,082 A	12/1963	Sanoff
3,528,359 A	9/1970	Sand
3,680,468 A	8/1972	Schueler
D226,381 S	2/1973	Harty
3,719,058 A	3/1973	Waygood
3,727,537 A	4/1973	Harty

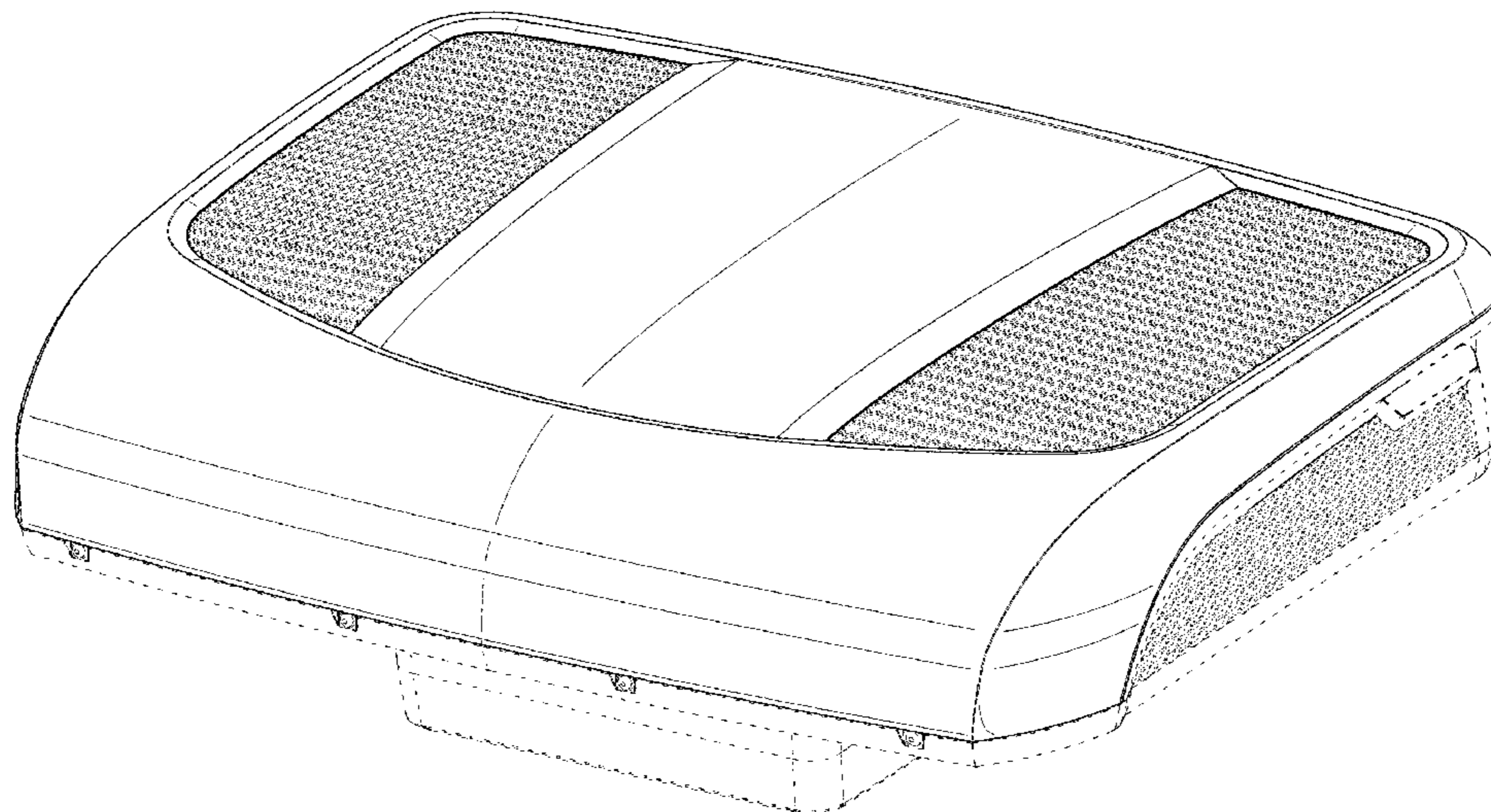

(56)

References Cited

U.S. PATENT DOCUMENTS

3,974,755 A	8/1976	Honmann	6,761,038 B1	7/2004	Bushnell et al.
4,043,143 A	8/1977	Fluder et al.	D495,041 S	8/2004	Thomas
4,051,691 A	10/1977	Dawkins	6,814,660 B1	11/2004	Cavett
4,189,987 A	2/1980	Amberg et al.	6,857,953 B2	2/2005	Malott
D257,637 S	12/1980	Armbruster	6,889,762 B2	5/2005	Zeigler et al.
4,502,368 A	3/1985	Hempel	7,086,740 B2	8/2006	Sample
4,502,467 A	3/1985	Smith	7,140,192 B2	11/2006	Allen et al.
4,550,648 A	11/1985	Eagle	7,171,822 B2	2/2007	Allen et al.
D284,025 S	5/1986	Armstrong	D538,413 S	3/2007	Lyu et al.
4,608,834 A	9/1986	Rummer	7,201,010 B2	4/2007	Homan et al.
4,637,299 A	1/1987	Harding	D541,917 S	5/2007	Pfeiffer
4,641,502 A	2/1987	Aldrich et al.	7,234,315 B2	6/2007	Allen et al.
4,665,804 A	5/1987	Muyasaka	7,237,397 B2	7/2007	Allen
4,672,818 A	6/1987	Roth	D554,544 S	11/2007	Englert
4,690,040 A	9/1987	Barnett	D560,785 S	1/2008	Galeazzi
4,693,174 A	9/1987	Anderson	7,316,119 B2	1/2008	Allen
4,709,623 A	12/1987	Roth et al.	7,334,834 B2	2/2008	Hill et al.
D296,583 S	7/1988	Barradas	7,441,414 B2	10/2008	Ziehr et al.
4,760,773 A	8/1988	Pezzulli	7,448,227 B2	11/2008	Zeigler et al.
D300,777 S	4/1989	Bales et al.	7,454,922 B2	11/2008	Zeigler et al.
D306,341 S	2/1990	Bales et al.	7,591,143 B2	9/2009	Zeigler et al.
5,056,262 A	10/1991	Schweiss et al.	7,591,303 B2	9/2009	Zeigler et al.
5,176,570 A	1/1993	Leidl	D619,151 S	7/2010	Tsuji
D343,894 S	2/1994	Anderson	7,797,958 B2	9/2010	Alston et al.
5,307,645 A	5/1994	Pannell	7,832,221 B2	11/2010	Wijaya et al.
5,366,149 A	11/1994	Kline	D629,094 S	12/2010	Thomas
5,403,183 A	4/1995	Andersson et al.	7,845,187 B2	12/2010	Patel et al.
D360,681 S	7/1995	Chopko	7,934,387 B2	5/2011	Lee et al.
5,435,781 A	7/1995	Kitchens	7,963,117 B2	6/2011	Allen et al.
D367,524 S	2/1996	Waldschmidt et al.	8,015,833 B2	9/2011	Cikanek et al.
5,494,244 A	2/1996	Walton	8,096,482 B2	1/2012	Dage
5,501,634 A	3/1996	Wilder	8,171,866 B2	5/2012	Dunstan
5,531,641 A	7/1996	Aldrich et al.	D661,386 S	6/2012	Bergin
5,556,335 A	9/1996	Holyoake	8,249,749 B2	8/2012	Dage et al.
5,588,910 A	12/1996	Hutter et al.	D672,450 S	12/2012	Milks et al.
5,632,156 A	5/1997	Takeo et al.	8,453,722 B2	6/2013	Zeigler et al.
5,643,081 A	7/1997	Klein	8,535,127 B2	9/2013	Malott
D391,632 S	3/1998	Thomas	8,568,209 B2	10/2013	Boxum
5,727,998 A	3/1998	Kreuger et al.	D712,531 S	9/2014	Bergin
5,752,877 A	5/1998	Sun	D715,907 S	10/2014	Bergin
5,765,383 A	6/1998	Inoue	D716,925 S	11/2014	Bergin
5,860,856 A	1/1999	Teich et al.	D782,939 S	4/2017	Allard
5,863,310 A	1/1999	Brown et al.	9,631,832 B2	4/2017	Malott
5,964,910 A	10/1999	Keele	D785,771 S	5/2017	Bergin et al.
D424,184 S	5/2000	Chang-Kwon	D785,772 S	5/2017	Bergin et al.
6,066,041 A	5/2000	Hernandez et al.	D811,566 S *	2/2018	Liu D23/325
6,073,456 A	6/2000	Kawai et al.	D824,499 S *	7/2018	Williamson D23/325
6,076,370 A	6/2000	Da Silva	2001/0053668 A1	12/2001	Berger
D428,480 S	7/2000	Flanagan	2003/0162492 A1	8/2003	Caferro et al.
6,101,829 A	8/2000	Robinson	2003/0220070 A1	11/2003	Orendorff et al.
6,116,037 A	9/2000	Burnett	2004/0005854 A1	1/2004	Shin
6,149,513 A	11/2000	Lyu	2004/0038643 A1	2/2004	Katagiri et al.
D435,639 S	12/2000	Slavonia et al.	2004/0072532 A1	4/2004	Cho
6,171,062 B1	1/2001	Bucher et al.	2004/0127152 A1	7/2004	Malott
D437,396 S	2/2001	Flanagan	2005/0087332 A1	4/2005	Umeo et al.
6,196,914 B1	3/2001	Lyu	2005/0227609 A1	10/2005	Koessler
6,234,893 B1	5/2001	Meredith	2006/0026936 A1	2/2006	Paumier et al.
6,241,794 B1	6/2001	Jadran et al.	2006/0052050 A1	3/2006	Malott et al.
6,250,373 B1	6/2001	Vecchi et al.	2006/0083889 A1	4/2006	Schuckers
6,257,976 B1	7/2001	Richardson, III	2006/0179871 A1	8/2006	Wagner
6,302,780 B1	10/2001	Ahn et al.	2007/0000265 A1	1/2007	McEnaney et al.
6,339,934 B1	1/2002	Yoon	2007/0066215 A1	3/2007	Song et al.
D454,625 S	3/2002	Flanagan	2007/0131408 A1	6/2007	Zeigler et al.
6,351,957 B2	3/2002	Hara	2007/0157522 A1	7/2007	Hebert et al.
6,367,270 B2	4/2002	Niimi et al.	2007/0227168 A1	10/2007	Simmons
6,370,899 B1	4/2002	Hobbs et al.	2007/0227693 A1	10/2007	Allen et al.
6,370,906 B1	4/2002	Kuo	2007/0287374 A1	12/2007	Day et al.
6,415,622 B2	7/2002	Kim et al.	2007/0298702 A1	12/2007	Boxum
6,536,222 B1	3/2003	Ahn et al.	2007/0299560 A1	12/2007	LaHue et al.
6,554,880 B1	4/2003	Northcutt	2008/0014852 A1	1/2008	Mielke et al.
6,571,572 B2	6/2003	Hobbs et al.	2008/0034767 A1	2/2008	Ziehr et al.
6,601,356 B2	8/2003	Snyder	2008/0146136 A1	6/2008	Degutis et al.
6,616,523 B1	9/2003	Tani et al.	2009/0098820 A1	4/2009	Yabu
6,626,003 B1	9/2003	Kortum et al.	2009/0107743 A1	4/2009	Alston et al.
6,745,586 B1	6/2004	Reimann et al.	2010/0089563 A1	4/2010	Sundhar
			2010/0224754 A1	9/2010	Khan
			2011/0016894 A1	1/2011	Lemon et al.
			2011/0067420 A1	3/2011	Alston et al.
			2011/0302942 A1	12/2011	Birchard

(56)

References Cited

U.S. PATENT DOCUMENTS

2012/0210733	A1	8/2012	Kolavennu et al.
2012/0247131	A1	10/2012	Esch
2012/0324927	A1	12/2012	Suzuki
2013/0047648	A1	2/2013	Zeigler et al.
2013/0109294	A1	5/2013	Tolinski et al.
2013/0157557	A1	6/2013	Malott
2013/0185939	A1	7/2013	Zapotocky et al.
2013/0205811	A1	8/2013	Esch
2014/0033742	A1	2/2014	Esch
2014/0188313	A1	7/2014	Huang
2014/0223928	A1	8/2014	Esch
2014/0260393	A1	9/2014	Siddiqui
2015/0087216	A1	3/2015	Stover et al.
2015/0107814	A1	4/2015	Jeong
2015/0251521	A1	9/2015	Brauer et al.
2015/0352924	A1	12/2015	Allard
2016/0076271	A1	3/2016	Reinking
2016/0207372	A1	7/2016	Parry
2017/0203632	A1	7/2017	Westendarp et al.

FOREIGN PATENT DOCUMENTS

AU	201613590	7/2016
AU	201613591	7/2016
AU	201613592	7/2016
AU	201613593	7/2016
AU	201712794	5/2017
AU	201712798	5/2017
CA	1011592	6/1977
CA	167431	3/2016
CA	172872	3/2016
CA	172873	3/2016
CA	172874	3/2016
CA	165232	5/2016
CA	165233	5/2016
CN	202419811	U 9/2012
CN	2016303225243.2	4/2017
CN	106976376	7/2017
EM	003323740	7/2016
EM	003421643	10/2016
EM	003479179	11/2016
EP	0180053	10/1985
EP	0064769	8/1986
EP	1681517	7/2006
EP	1832452	9/2007
FR	2087220	12/1971
GB	2297157	7/1996
JP	52137854	11/1977
JP	2004125338	4/2004
KR	2005119747	A 12/2005
KR	10-2013-0001913	A 1/2013
WO	2004099681	11/2004
WO	2014143181	9/2014
WO	2015/126019	A1 8/2015
WO	15134185	9/2015

OTHER PUBLICATIONS

10-Minute Tech, Trailer Life, Jul. 1996, pp. 69-70 dated Jul. 1, 1996.
 American RV Company, Dometic 459530 Duo Therm 13,500 BTU Brisk Air Conditioner High Efficiency Upper Unit Trailer Camper RV, Mar. 23, 2014 <https://web.archive.org/web/20140323013456/http://www.americanrvcompany.com/Dometic-459530-Duo-Therm-13500-BTU-Brisk-Air-Conditioner-High-Efficiency-Upper-Unit-Trailer-Camper-RV> Mar. 23, 2014.
 American RV Company, Dometic 541815 High Performance 13,500 BTU Air Conditioner Upper Unit CCC2 Required Electronics Pre-Installed Camper Trailer RV, <http://www.americanrvcompany.com/Dometic-541815-High-Performance-13500-BTU-Air-Conditioner-Upper-Unit-CCC2-Required-Electronics-Pre-Installed-Camper-Trailer-RV> Mar. 23, 2014.
 American RV Company, Dometic 541816 High Performance 15,000 BTU Air Conditioner Upper Unit CCC2 Required Electronics

Pre-Installed Camper Trailer RV, <http://www.americanrvcompany.com/Dometic-541816-High-Performance-15000-BTU-Air-Conditioner-Upper-Unit-CCC2-Required-Electronics-Pre-Installed-Camper-Trailer-RV> Mar. 23, 2014.
 American RV Company, Dometic 541916 High Performance 15,000 BTU Air Conditioner Upper Unit Single Zone LCD Thermostat Required Electronics Pre-Installed Camper Trailer RV, <http://www.americanrvcompany.com/Dometic-541916-High-Performance-15000-BTU-Air-Conditioner-Upper-Unit-Single-Zone-LCD-Thermostat-Required-Electronics-Pre-Installed-Camper-Trailer-RV> Mar. 23, 2014.
 American RV Company, Dometic 551816 High Performance 15,000 BTU Heat Pump for Comfort Control Center II Camper Trailer RV, <http://www.americanrvcompany.com/Dometic-551816-High-Performance-15000-BTU-Heat-Pump-for-Comfort-Control-Center-II-Camper-Trailer-RV> Mar. 23, 2014.
 Australian Patent Application 2017220186 entitled "Parking Cooler" filed Jan. 11, 2017.
 Chinese Patent Application 201710040123.1 entitled "Parking Cooler" filed Jan. 18, 2017.
 European Patent Application 17152275.8 entitled "Parking Cooler" filed Jan. 19, 2017.
 Canadian Patent Application 2,906,348 entitled "Modular Air Grill Assembly" as filed Sep. 14, 2016 (national stage entry date).
 Dirna Bergstrom: Parking Coolers—No-Idle Electrical A/C—MiniCool Compact 1.4; <http://www.dirna.com/parking-coolers-no-idle-electrical-ac-compact/> Mar. 17, 2015.
 Dirna Bergstrom: Slim Cool; <http://www.dirna.com/files/dirna-manuals/220RE00183.pdf> May 21, 2014.
 Dometic Corporation, Dometic High Performance Air Conditioners, 2 pages, Jan. 1, 2011.
 Dometic Duo-Therm, p. 140. Feb. 22, 2013.
 Dometic Group: "Climate Control", <http://www.dometic.com/enus/Americas/USA/RV-Products/climate>, 2 pages, printed on Dec. 14, 2011.
 Dometic Waeco Coolair RT 880; <http://www.dometic.co.uk/product/waeco-coolair-rt-880-2/> May 14, 2015.
 Eberspacher Cooltronic Parking Coolers with High Efficiency with the Engine OFF; <http://www.eberspacher.com/products/air-conditioning/cooltronic-truck-parking-coolers.html> Jun. 23, 2015.
 European Design Patent Application No. 003300219 entitled "Air Shroud Assembly" filed Jul. 8, 2016.
 Indelb; WO Oblo'; Sleeping Well Oblo; http://www.indelb.com/products/parking_air_cooler/sleeping_well/sw_oblo Apr. 1, 2016.
 International Search Report and Written Opinion for PCT/US2013/065458 dated Jan. 29, 2014.
 Design U.S. Appl. No. 29/542,555 entitled "Modular Air Grill Design" filed Oct. 15, 2015.
 Design U.S. Appl. No. 29/552,019 entitled "Air Shroud Assembly" dated Jan. 19, 2016.
 Design U.S. Appl. No. 29/581,176 entitled "Air-Conditioning Unit" dated Oct. 17, 2016.
 Design U.S. Appl. No. 29/573,473 entitled "Recreational Vehicle Air-Conditioning Unit" filed Aug. 5, 2016.
 Design U.S. Appl. No. 29/594,476 entitled "Shroud Assembly" filed Feb. 17, 2017.
 Design U.S. Appl. No. 29/604,433 entitled "Air Conditioning Apparatus" filed May 17, 2017.
 Utility U.S. Appl. No. 15/407,709 entitled "Parking Cooler" filed Jan. 17, 2017.
 Webasto: Rooftop air conditioning systems: Rooftop 3.5-9.9 kw; <http://www.eberspacher.com/products/air-conditioning/cooltronic-truck-parking-coolers.html> May 14, 2014.
 Webasto; Truck parking cooler: Cool Top Vario 10 E; <http://www.webasto.com/gb/markets-products/truck/air-conditioning/products/cool-top-vario/> Apr. 25, 2016.
 Youtube; Viesa Kompressor; <https://www.youtube.com/watch?v=SPK17XEvVL0> May 22, 2012 (https://www.google.com/?gws_rd=ssl#q=https://www.youtube.com/watch?v%3DSPK17XEvVL0&spf=1495819902591), May 22, 2012.
 U.S. Patent and Trademark Office, Restriction Requirement for U.S. Appl. No. 29/552,019 dated May 19, 2017.
 U.S. Patent and Trademark Office, Office Action for U.S. Appl. No. 29/552,019 dated Aug. 4, 2017.

(56)

References Cited

OTHER PUBLICATIONS

U.S. Patent and Trademark Office, Notice of Allowance for U.S. Appl. No. 29/552,019 dated Jan. 11, 2018.

Design U.S. Appl. No. 29/620,394 entitled "Air Shroud Assembly" filed Oct. 4, 2017.

Partial European Search Report and Written Opinion for European Application No. 17152275.8 dated Sep. 17, 2017.

Extended European Search Report and Written Opinion for European Application No. 17152275.8 dated Mar. 7, 2018.

Office Action for European Application No. 17152275.8 dated Nov. 22, 2018.

Non-Final Office Action for U.S. Appl. No 15/407,709 dated May 15, 2019.

* cited by examiner

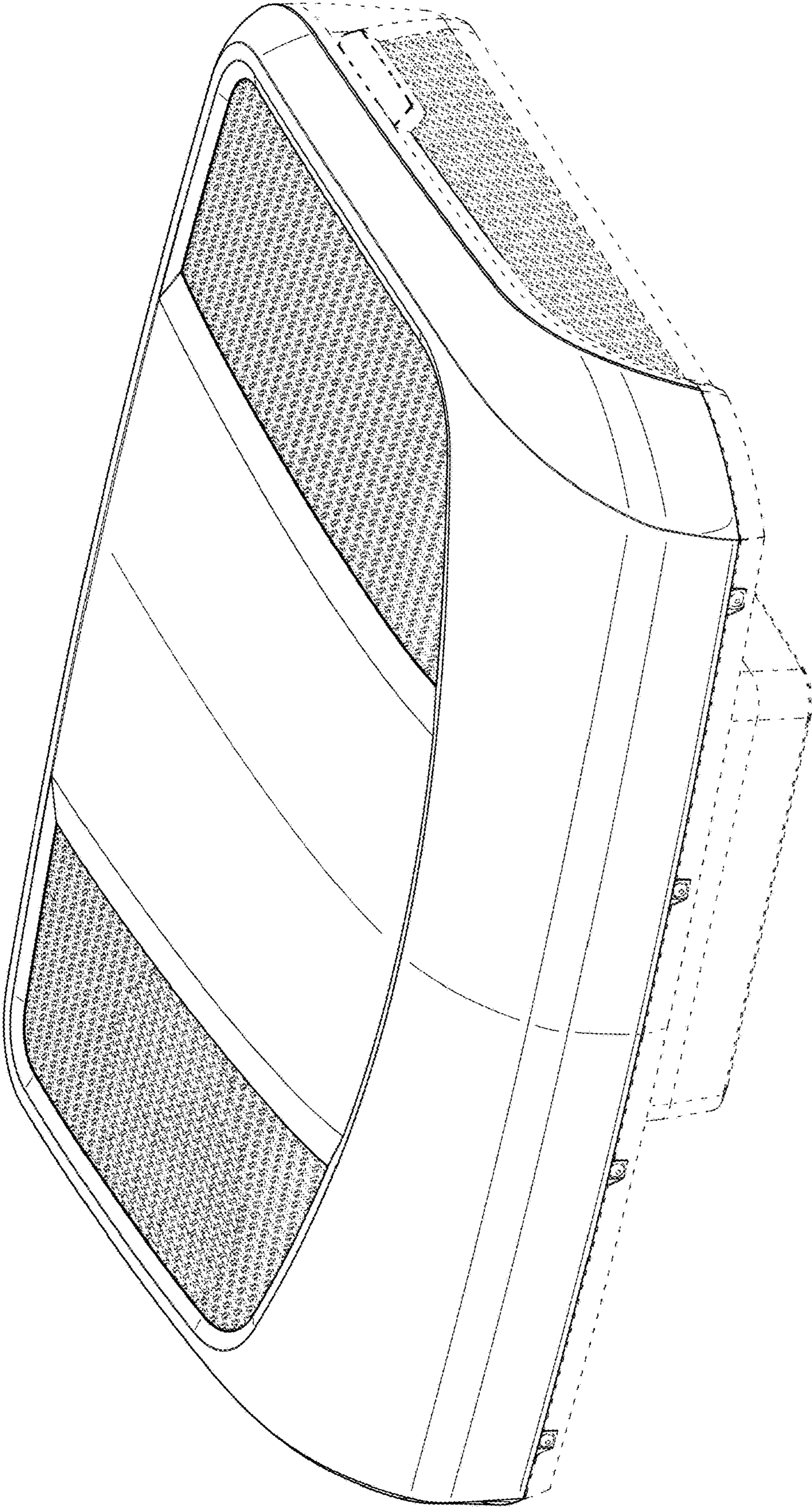

FIG. 1

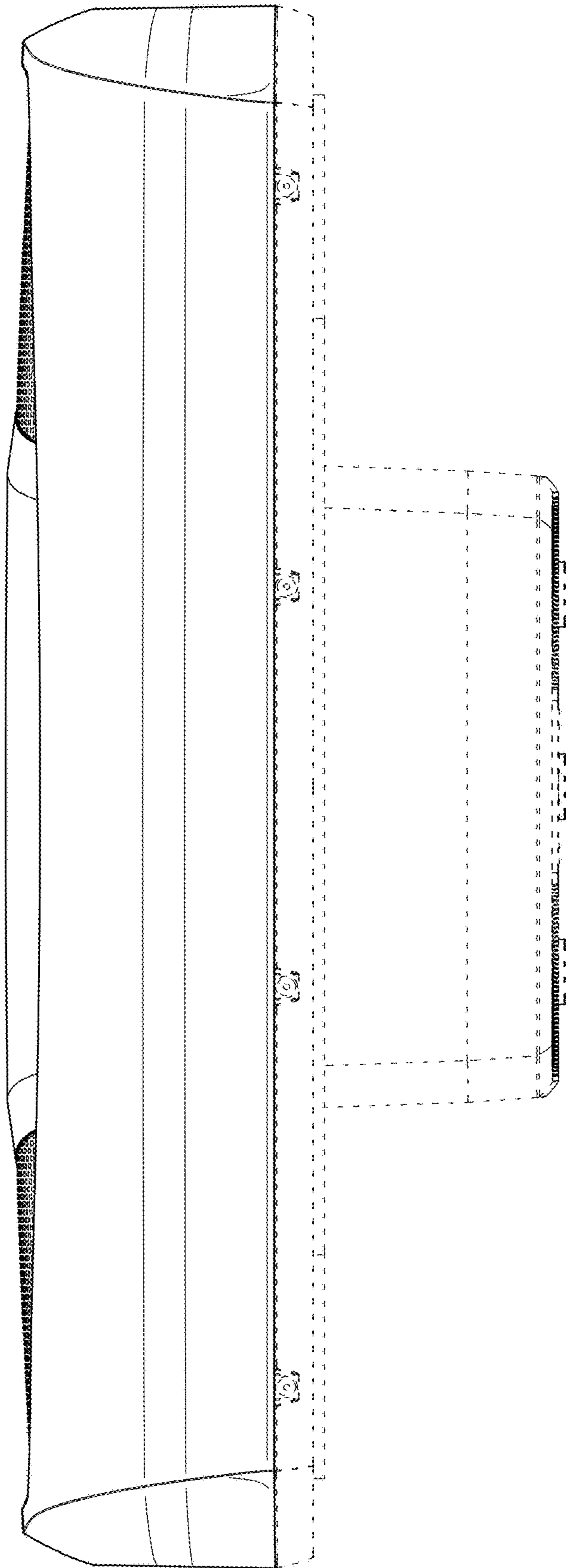

FIG. 2

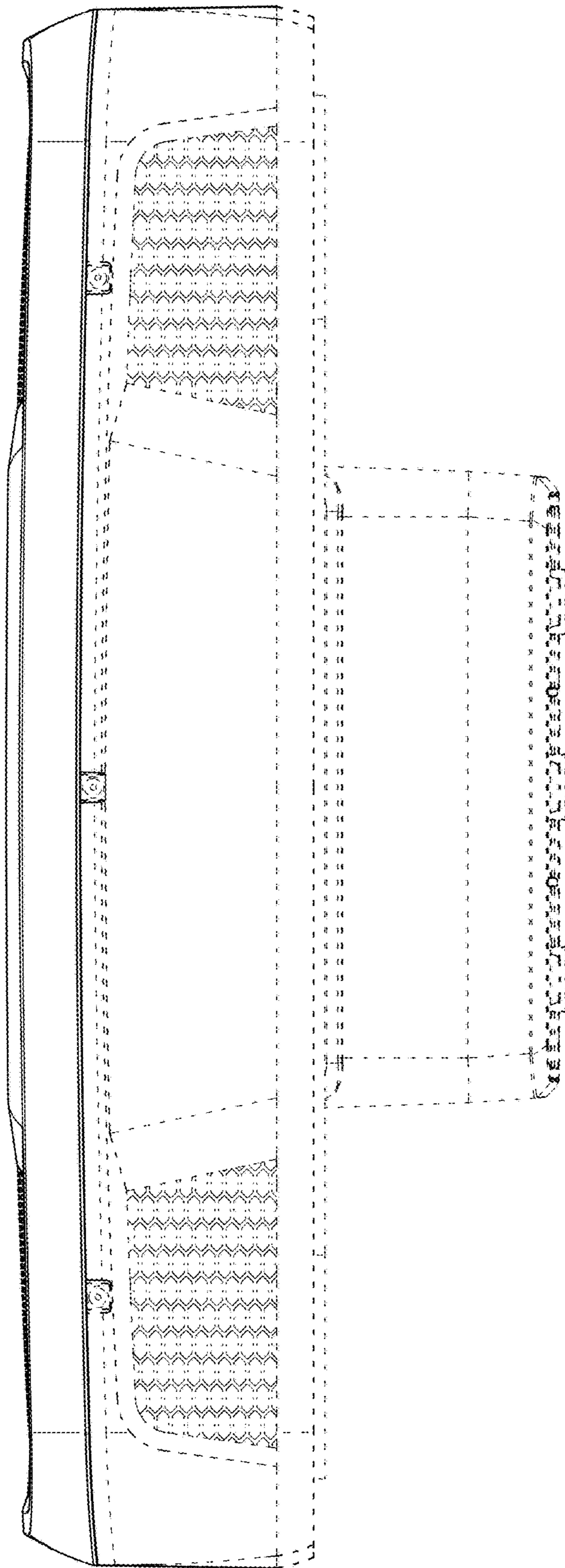

FIG. 3

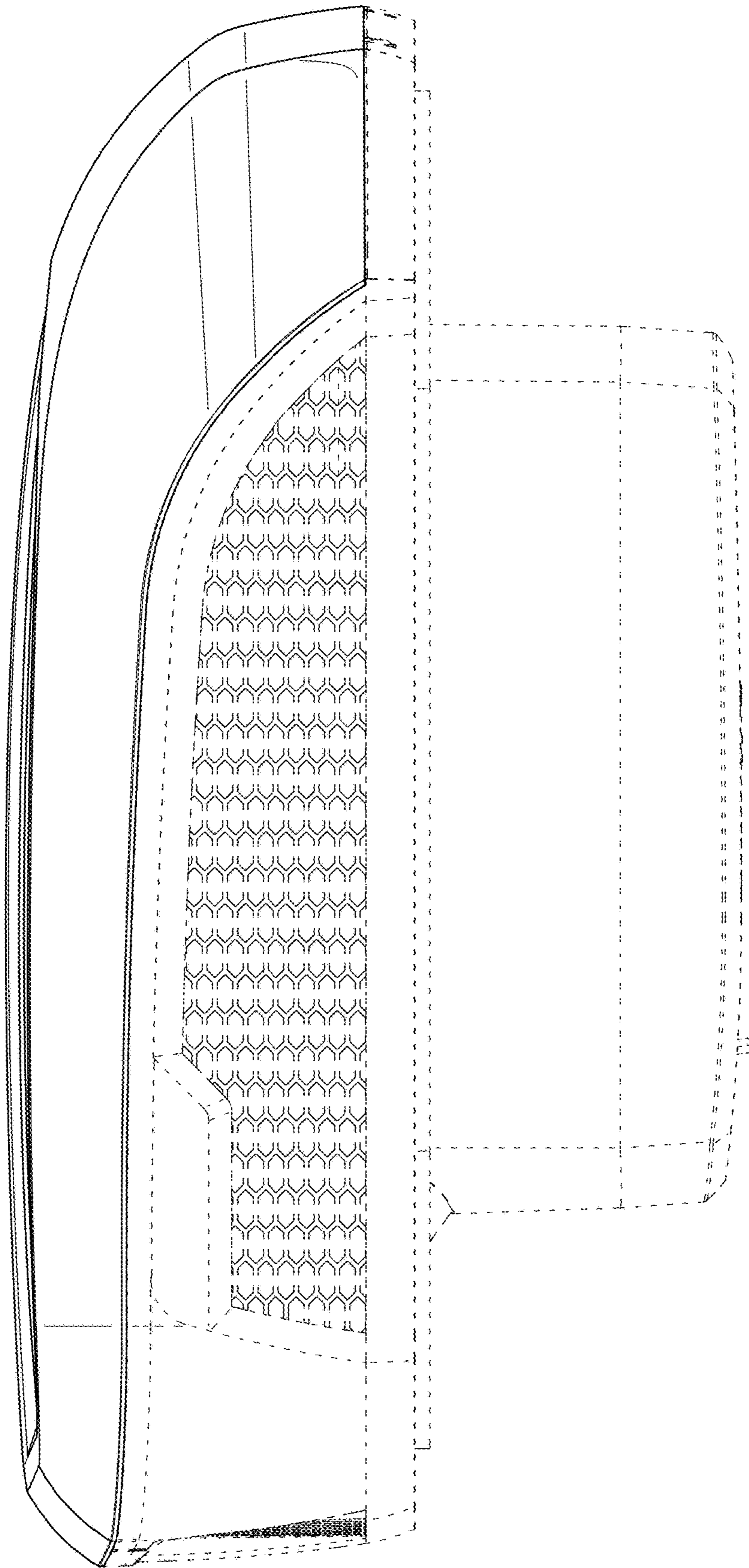

FIG. 4

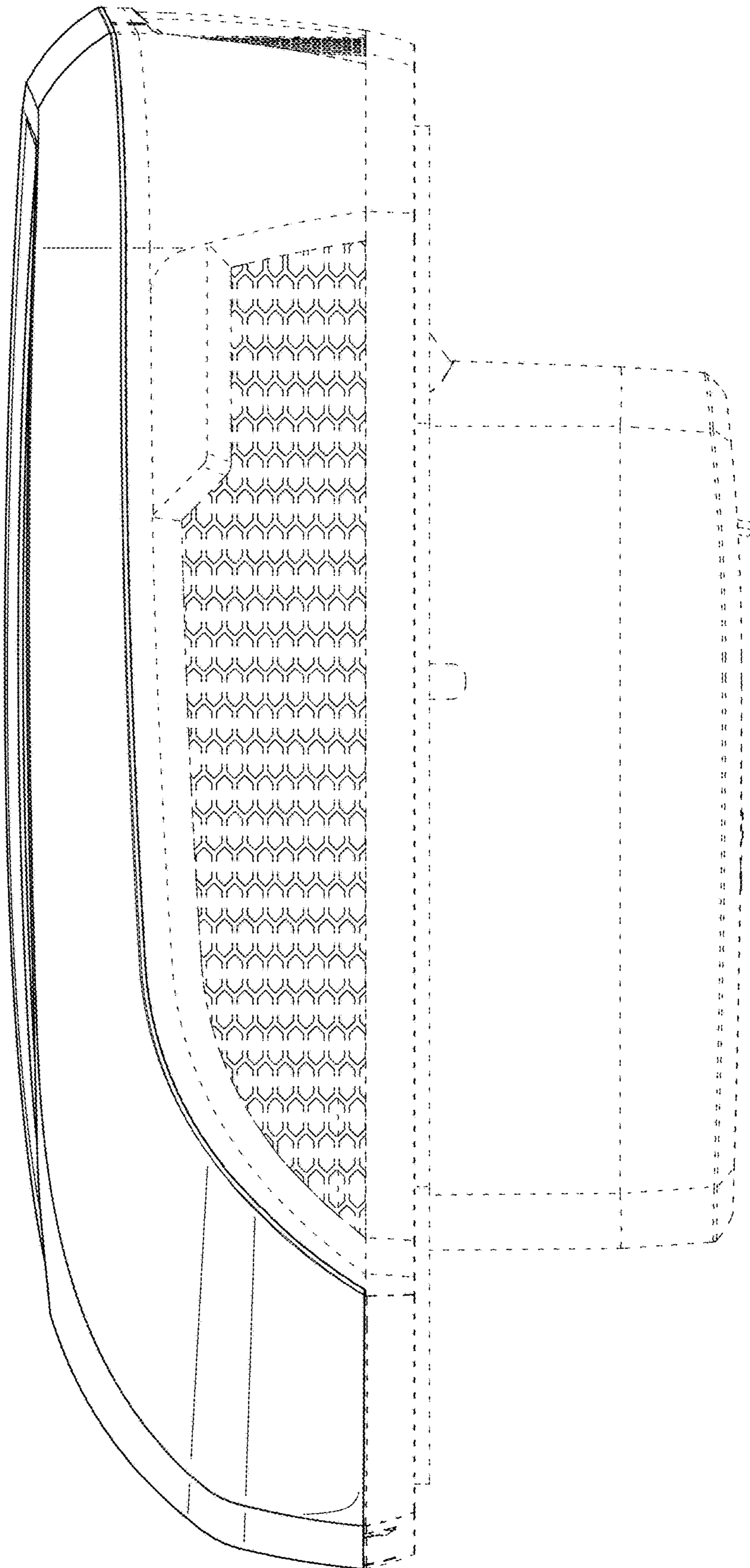

FIG. 5

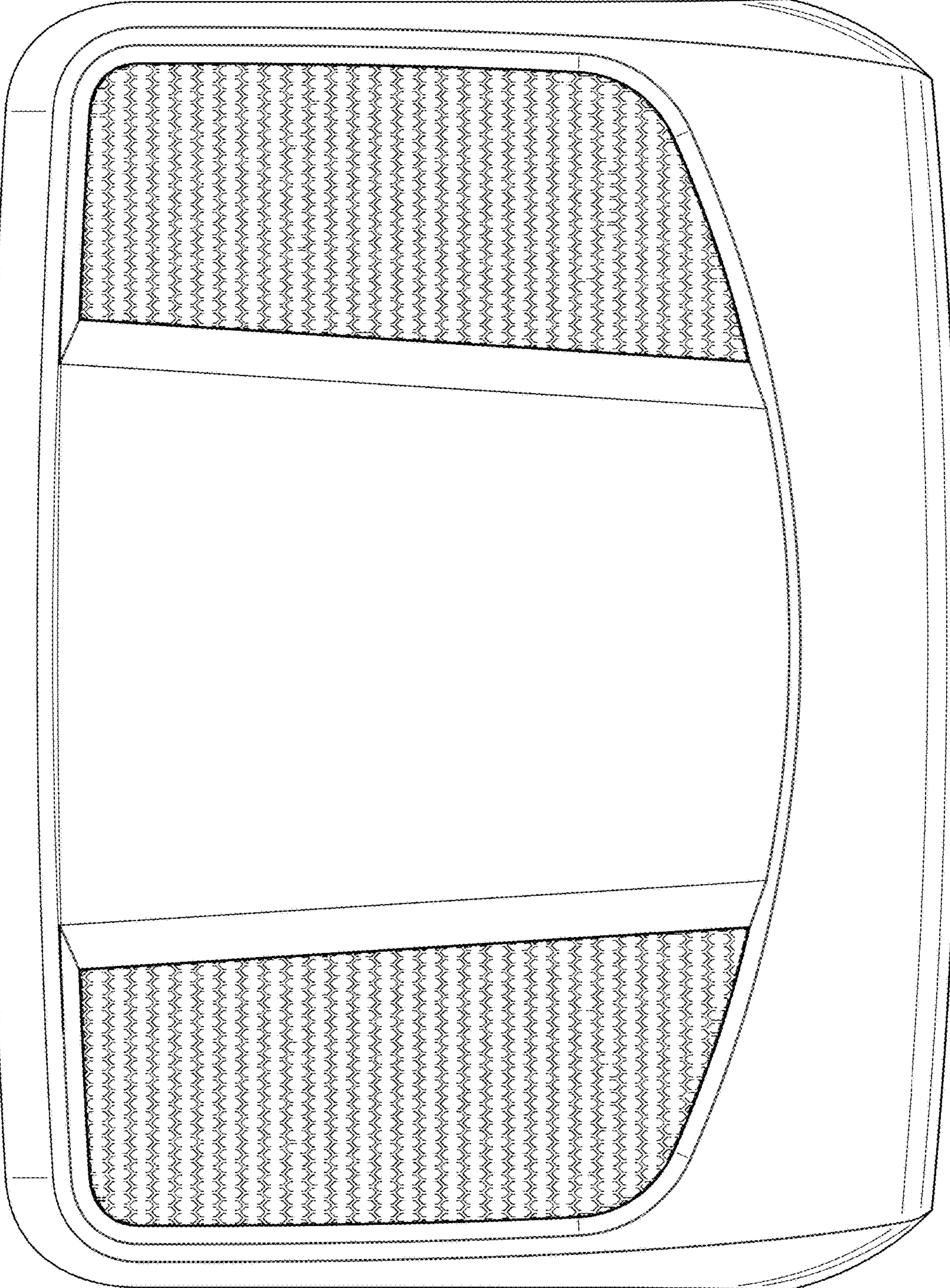

FIG. 6

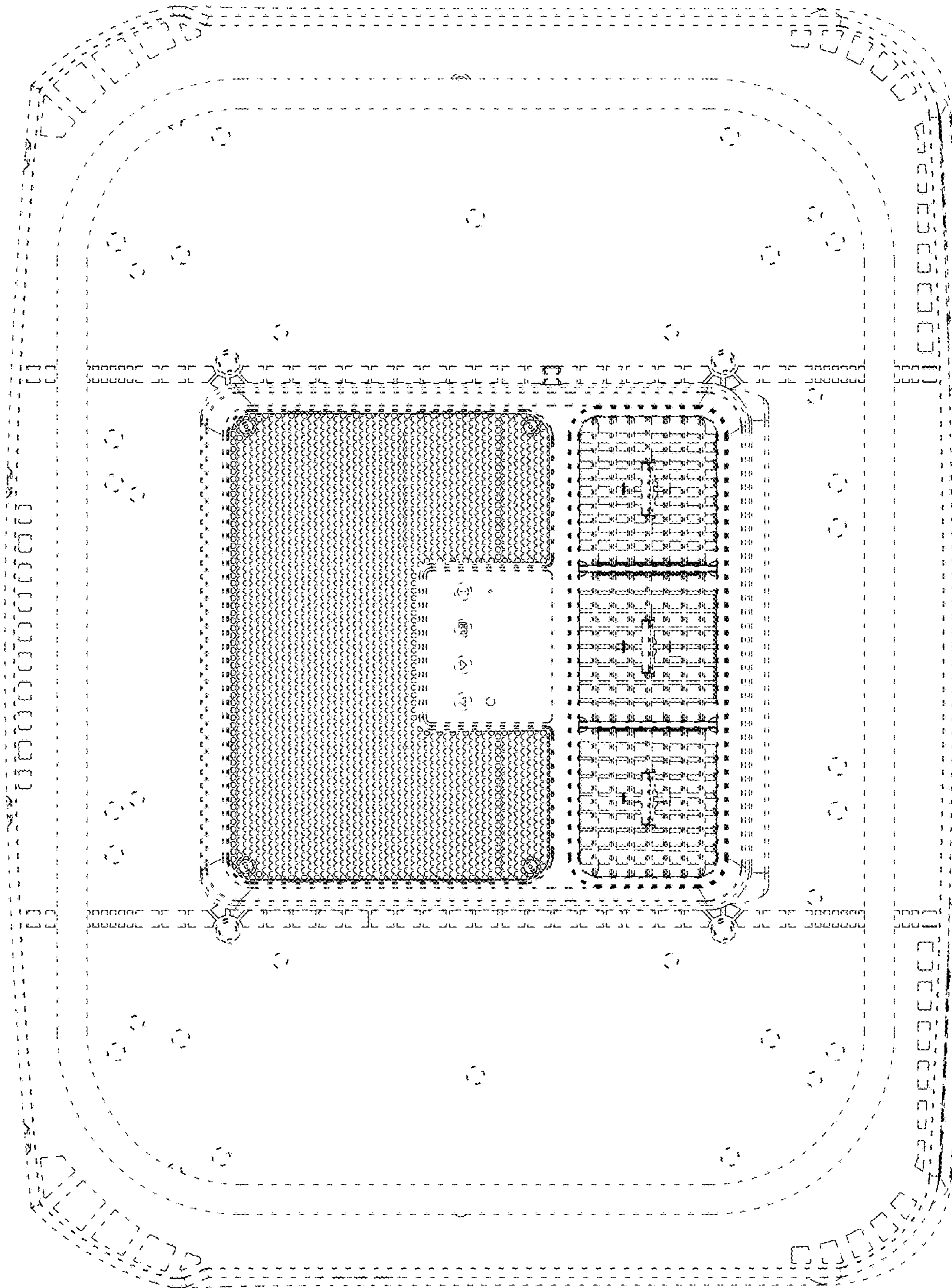

FIG. 7