



US00D862610S

(12) **United States Design Patent**
Barajas et al.

(10) **Patent No.:** **US D862,610 S**

(45) **Date of Patent:** **** Oct. 8, 2019**

(54) **BODY FOR A MODEL VEHICLE**

D293,310 S 12/1987 Clark et al.
D307,248 S 4/1990 Dettling
5,102,367 A 4/1992 Mullaney et al.

(71) Applicant: **TRAXXAS LP**, McKinney, TX (US)

(Continued)

(72) Inventors: **Jaime Felix Barajas**, Dallas, TX (US);
Otto Karl Allmendinger, Rowlett, TX
(US); **Casey Christen Jens**
Christensen, McKinney, TX (US); **Jory**
Sprowl, Wolfe City, TX (US); **Kent**
Poteet, Lucas, TX (US)

OTHER PUBLICATIONS

Hot Wheels Skull Crusher Diecast Toy Car-Race Vehicle by Mattel-
Auto Racing Toys Cars Collection, Feb. 22, 2012, [online], [Retrieved
on Aug. 10, 2015] URL: <https://www.youtube.com/watch?v=fR1BWC9bqzM>.

(Continued)

(73) Assignee: **TRAXXAS LP**, McKinney, TX (US)

Primary Examiner — Manpreet S Matharu

(**) Term: **15 Years**

Assistant Examiner — Keith J Wilson

(21) Appl. No.: **29/633,364**

(74) *Attorney, Agent, or Firm* — Daryl R. Wright; Greg
Carr

(22) Filed: **Jan. 12, 2018**

(57) **CLAIM**

(51) **LOC (12) Cl.** **21-01**

We claim the ornamental design for a body for a model
vehicle, as shown and described.

(52) **U.S. Cl.**

DESCRIPTION

USPC **D21/548**; D12/86

(58) **Field of Classification Search**

USPC D12/86, 88, 90–92, 164, 173, 184–186,
D12/190, 196; D21/419, 421, 423,
D21/424–426, 433–434, 548, 549, 550,
D21/552, 559, 561

CPC A63H 17/26; A63H 17/262; A63H 17/264;
A63H 17/266; A63H 17/36; A63H 17/38;
A63H 29/00; A63H 29/22; A63H 29/24;
A63H 30/04

See application file for complete search history.

FIG. 1 is an upper, right, front perspective view of a body for
a model vehicle;
FIG. 2 is front elevation view thereof;
FIG. 3 is a rear elevation view thereof;
FIG. 4 is a left side elevation view thereof;
FIG. 5 is a right side elevation view thereof;
FIG. 6 is a top plan view thereof;
FIG. 7 is a bottom plan view thereof;
FIG. 8 is an upper, left, rear perspective view; and,
FIG. 9 is an upper, left, front perspective environmental use
view.

(56) **References Cited**

U.S. PATENT DOCUMENTS

D203,841 S 2/1966 Power
D243,595 S 3/1977 Belz
D251,725 S 5/1979 Cesaro
D253,406 S 11/1979 Carabetta
D254,128 S 2/1980 Carabetta
D277,494 S * 2/1985 Lerch D21/559
D281,000 S * 10/1985 Kuna D21/559

In the drawings, the broken line showing of features of body
for a model vehicle illustrate portions of the body for a
model vehicle that form no part of the claimed design;
whereas, the broken line showing of the environmental use
view depicts environmental subject matter and is provided
for the purposes of illustrating environmental use structure
and context.

1 Claim, 7 Drawing Sheets

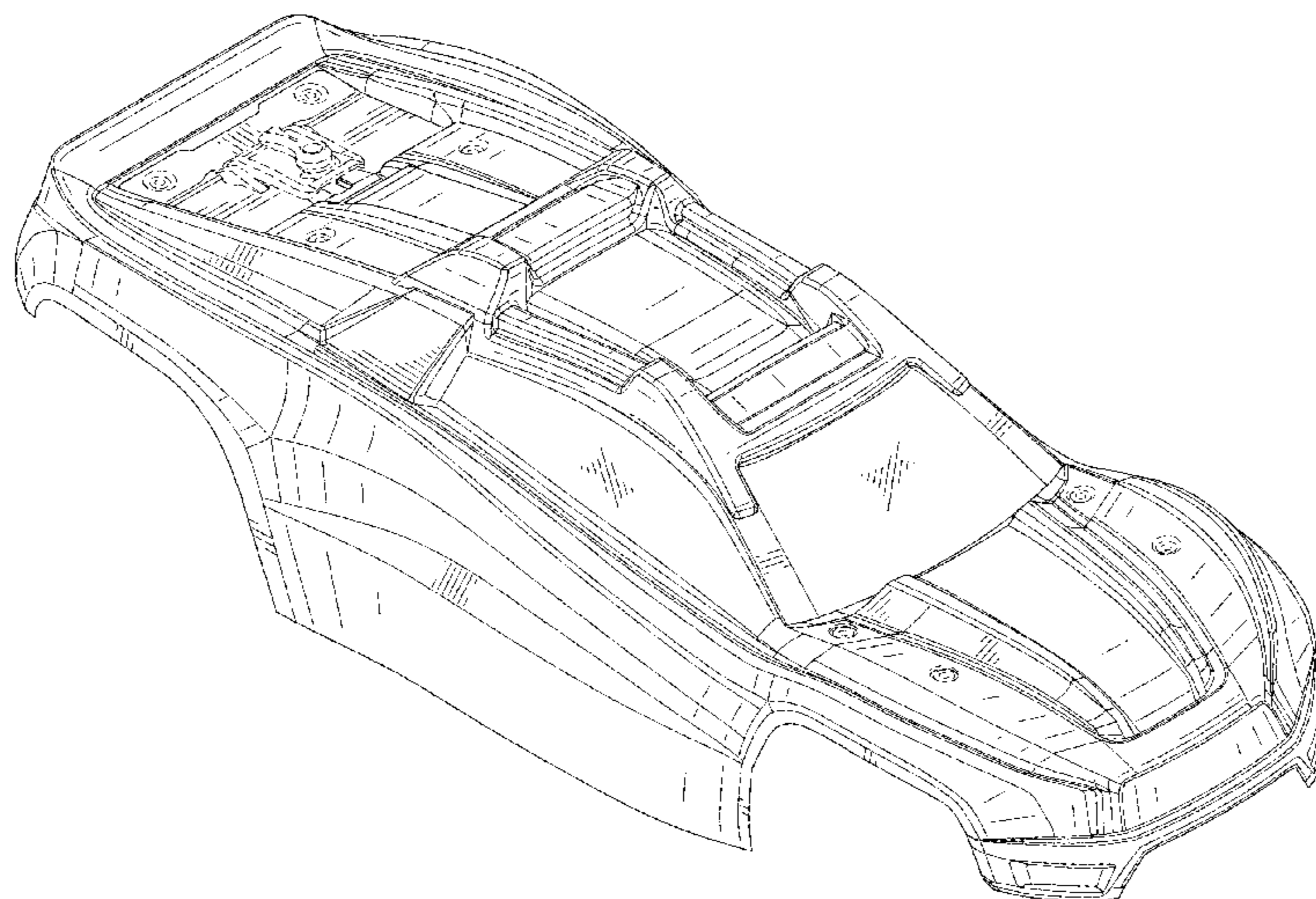

(56)

References Cited

U.S. PATENT DOCUMENTS

5,228,880 A 7/1993 Meyer et al.
 5,334,078 A 8/1994 Hippely et al.
 D385,245 S 10/1997 Gallitzendoerfer et al.
 D404,691 S 1/1999 Gerisch et al.
 D425,141 S 5/2000 Park
 D458,188 S 6/2002 Wyszogrod et al.
 D496,409 S * 9/2004 Tilbor D21/559
 D529,967 S 10/2006 Bowen et al.
 D538,861 S 3/2007 Takahashi
 7,217,170 B2 5/2007 Moll et al.
 D547,249 S * 7/2007 Kurtz D12/190
 D550,311 S 9/2007 Chen
 D566,788 S 4/2008 Pasko
 D566,789 S * 4/2008 Idiot D21/552
 D566,790 S * 4/2008 Idiot D21/552
 D567,301 S * 4/2008 Idiot D21/549
 7,387,558 B2 6/2008 Swisher et al.
 D579,823 S 11/2008 Choi
 D592,256 S 5/2009 Yaguchi
 D593,163 S 5/2009 Torres et al.
 D603,295 S * 11/2009 Honeycutt D12/86
 D605,083 S * 12/2009 Manoogian, II D12/86
 D612,767 S * 3/2010 Barkan D12/86
 D617,851 S 6/2010 Stoddard
 D630,971 S 1/2011 Jung
 D671,454 S 11/2012 Davidson et al.
 8,342,904 B2 1/2013 Torres

D693,737 S 11/2013 Hammoud et al.
 D707,608 S 6/2014 Smith
 D709,007 S 7/2014 Henry et al.
 D709,008 S 7/2014 Brzustowicz et al.
 D709,009 S 7/2014 Brzustowicz et al.
 D728,037 S * 4/2015 Barajas D21/548
 D741,416 S 10/2015 Barajas et al.
 D741,956 S 10/2015 Barajas et al.
 D769,378 S * 10/2016 Belker D21/549
 D770,339 S 11/2016 Lindsey
 D770,350 S 11/2016 Lindsey
 D770,575 S * 11/2016 Belker D21/549
 D771,202 S * 11/2016 Gan D21/552
 D771,203 S * 11/2016 Gan D21/552
 D792,526 S * 7/2017 Belker D21/561
 D802,685 S * 11/2017 Barajas D21/562
 D826,341 S 8/2018 Poteet et al.
 D826,342 S 8/2018 Poteet et al.
 D826,343 S 8/2018 Poteet et al.
 D827,056 S 8/2018 Poteet et al.
 D841,743 S 2/2019 Barajas et al.
 D842,386 S 3/2019 Barajas et al.
 D842,387 S 3/2019 Barajas et al.

OTHER PUBLICATIONS

PROTOform; Protoform Ford GT 2017; <http://racepf.com/on-road-1-10-1-12/ford-gt-clear-body/>; Sep. 2016.

* cited by examiner

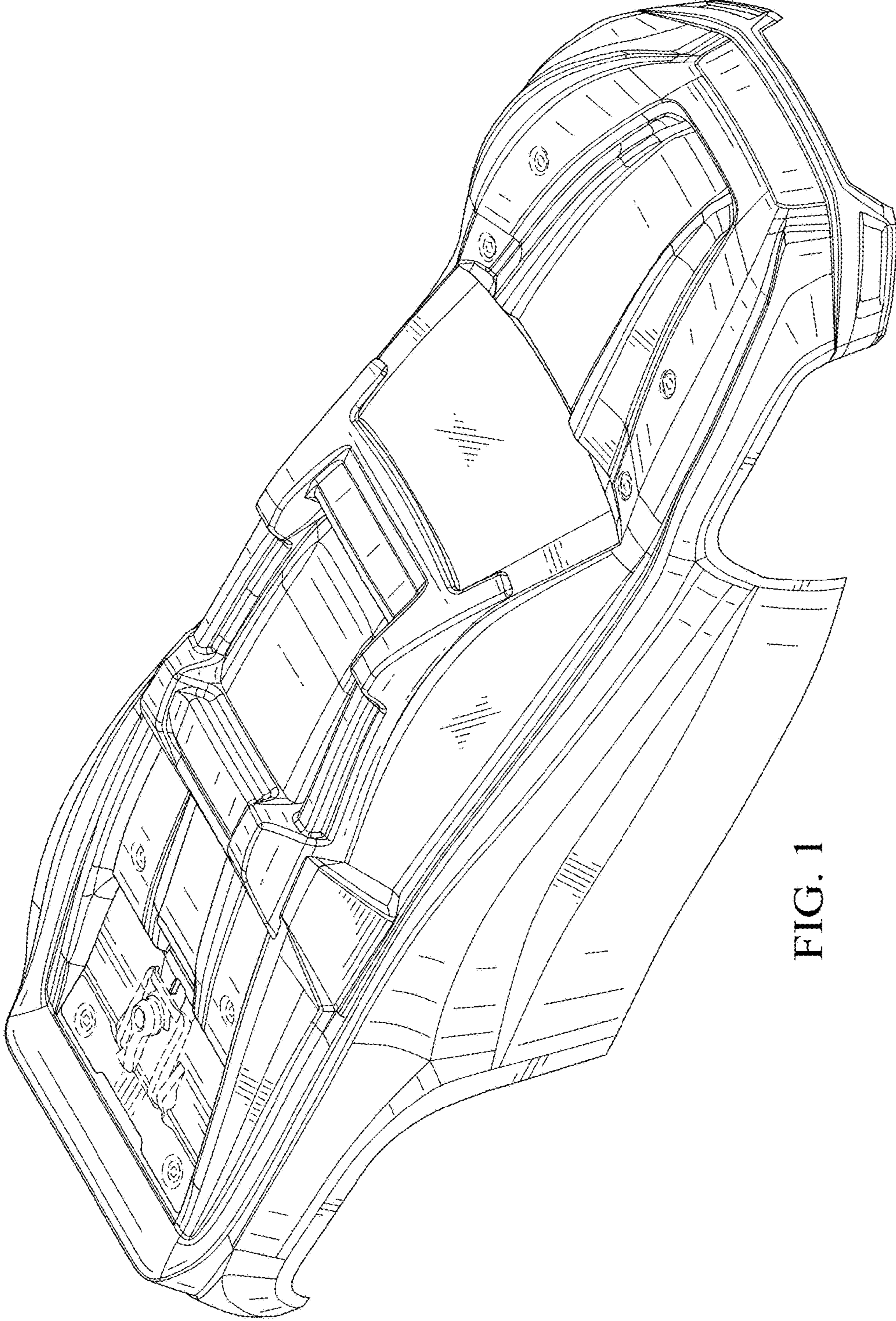

FIG. 1

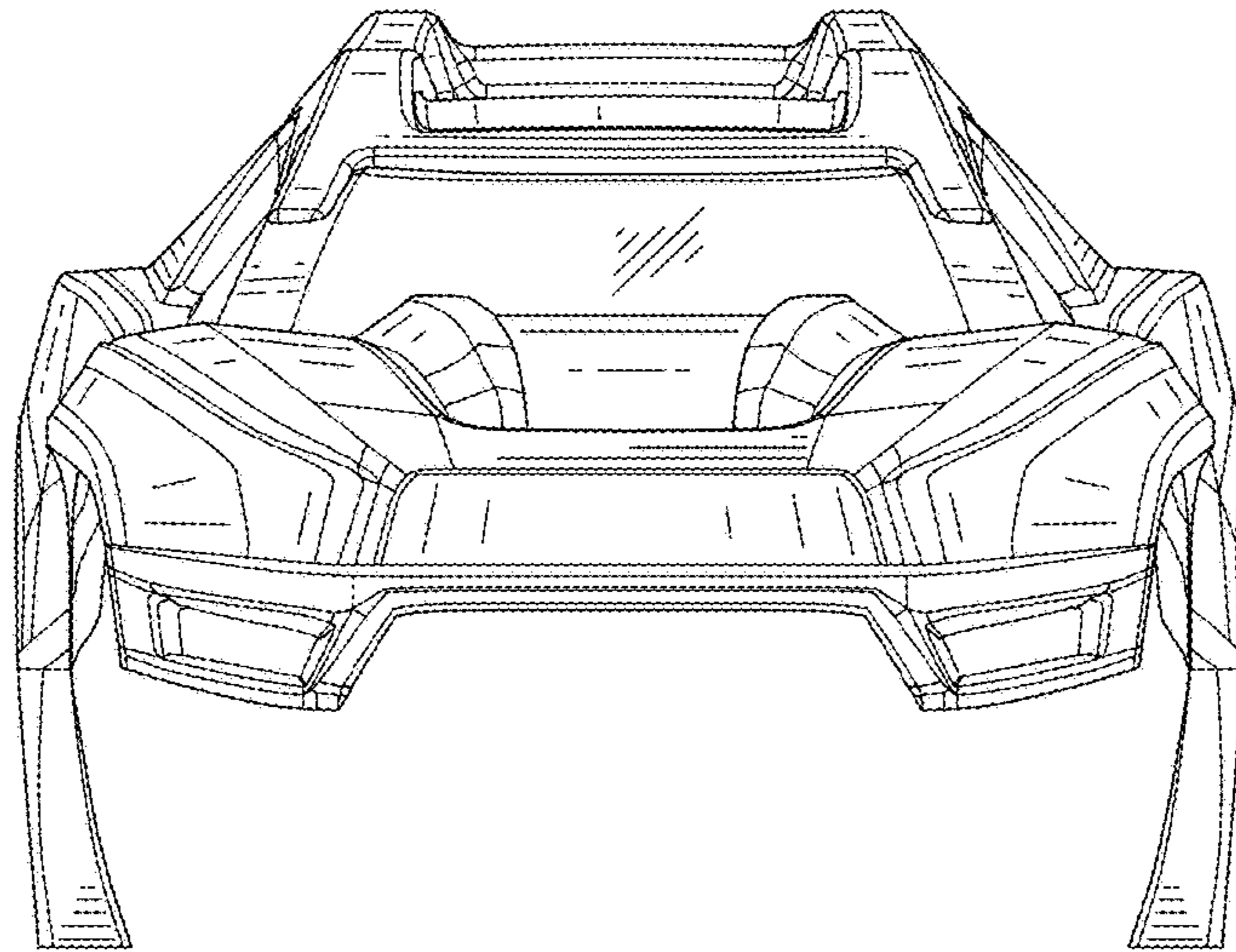

FIG. 2

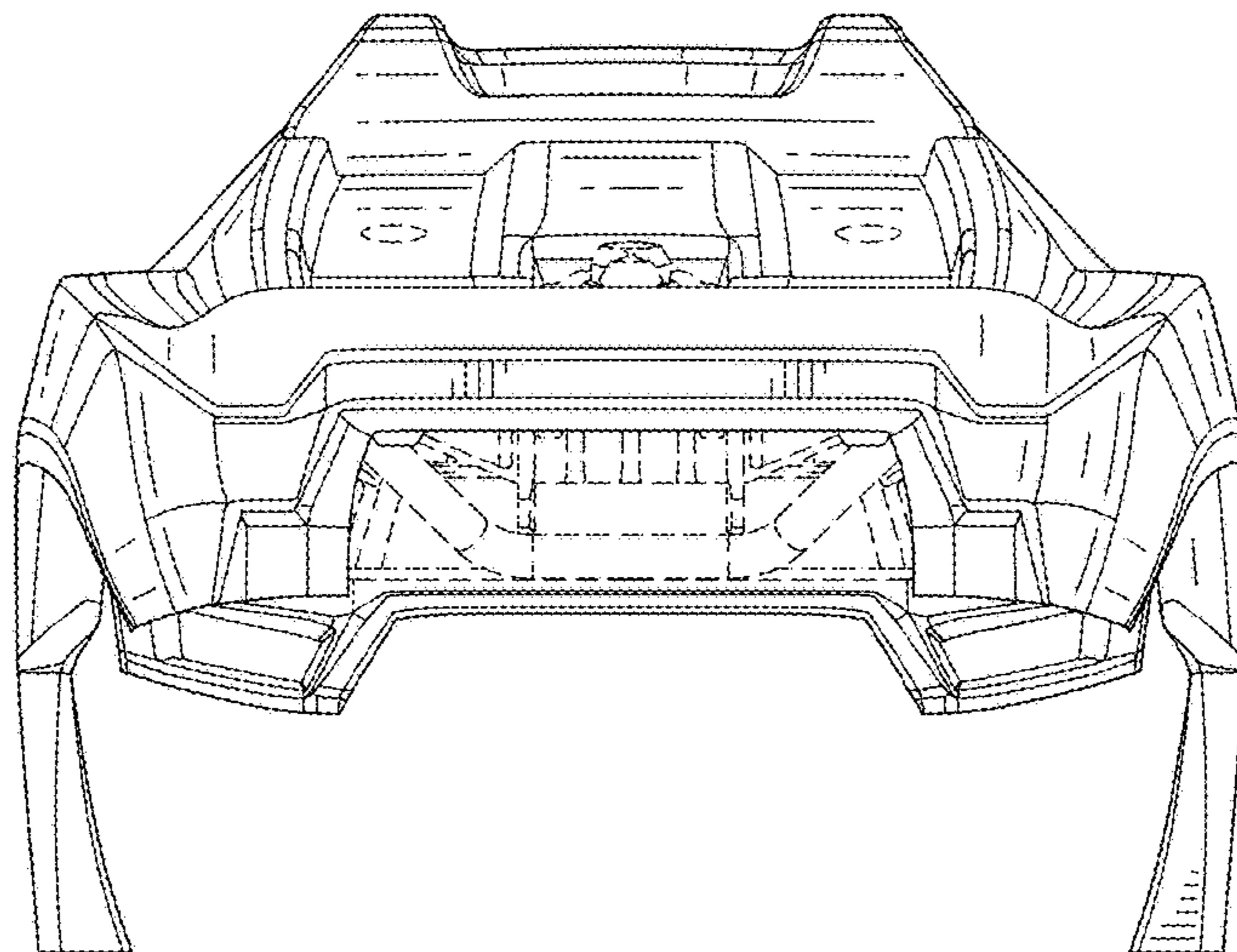

FIG. 3

FIG. 4

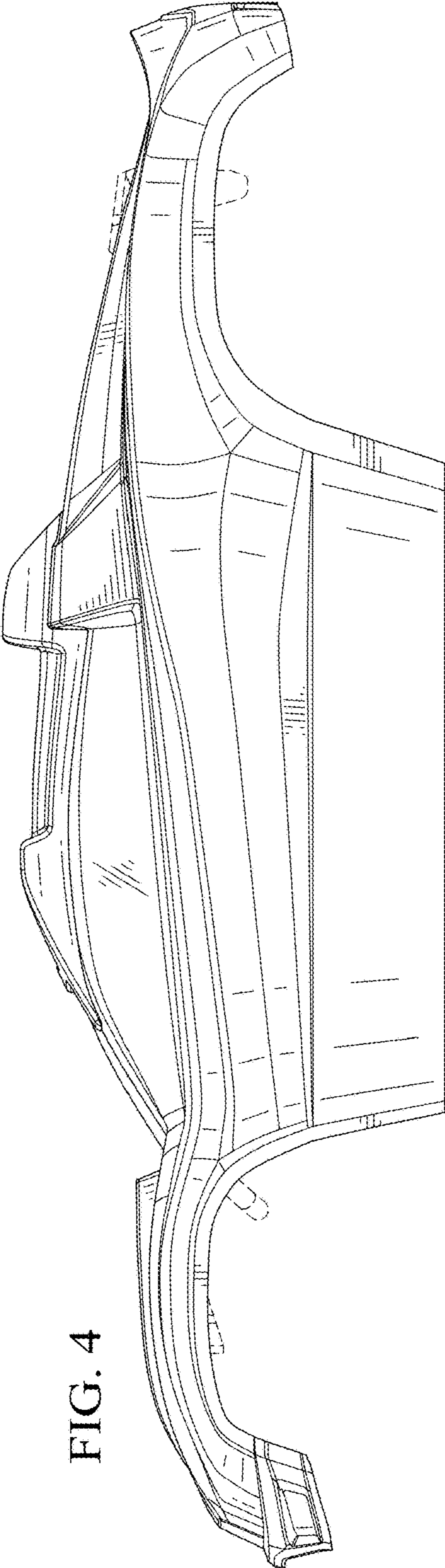
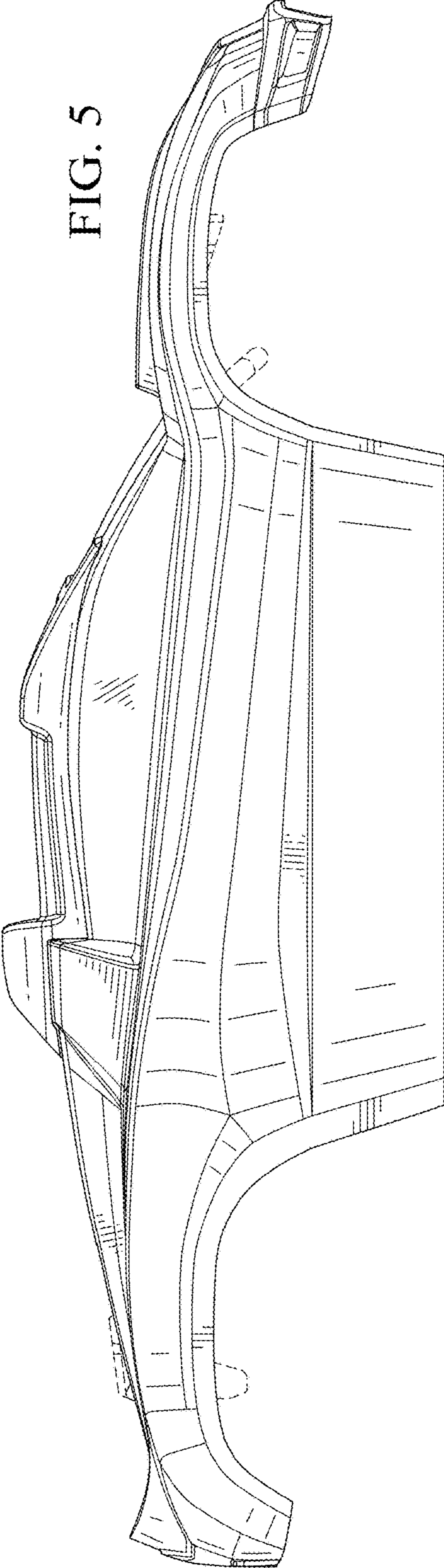

FIG. 5



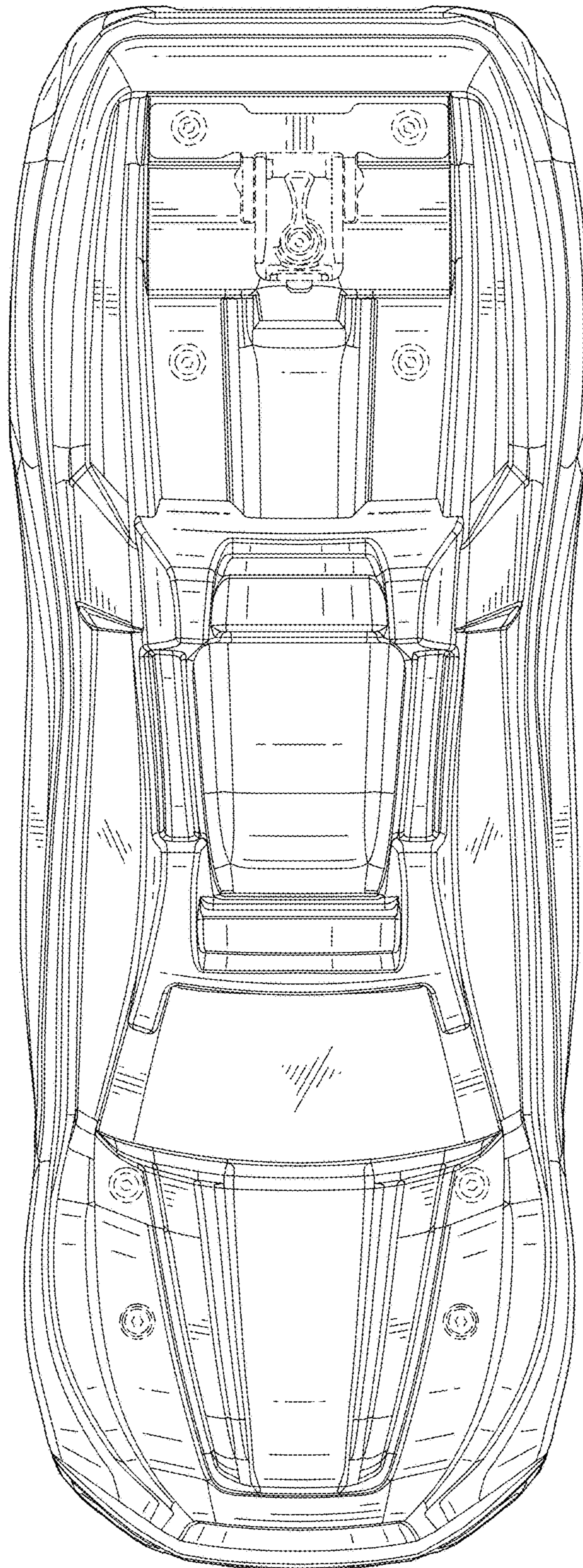

FIG. 6

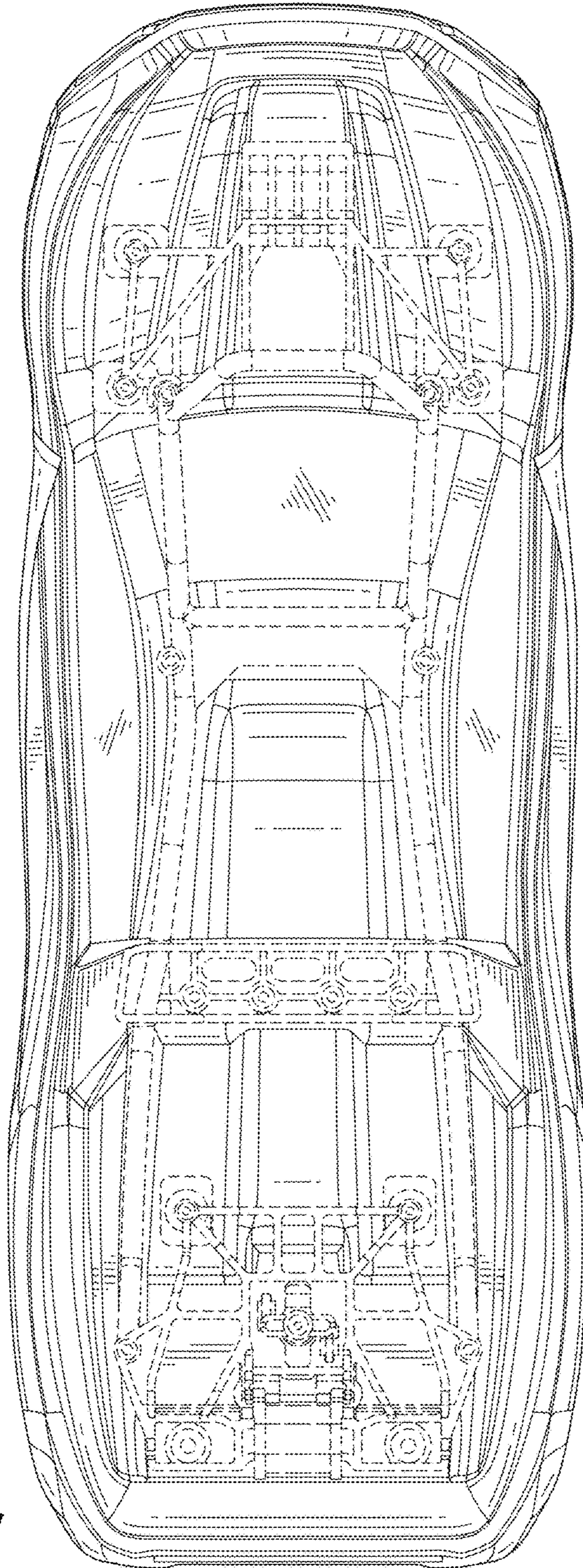

FIG. 7

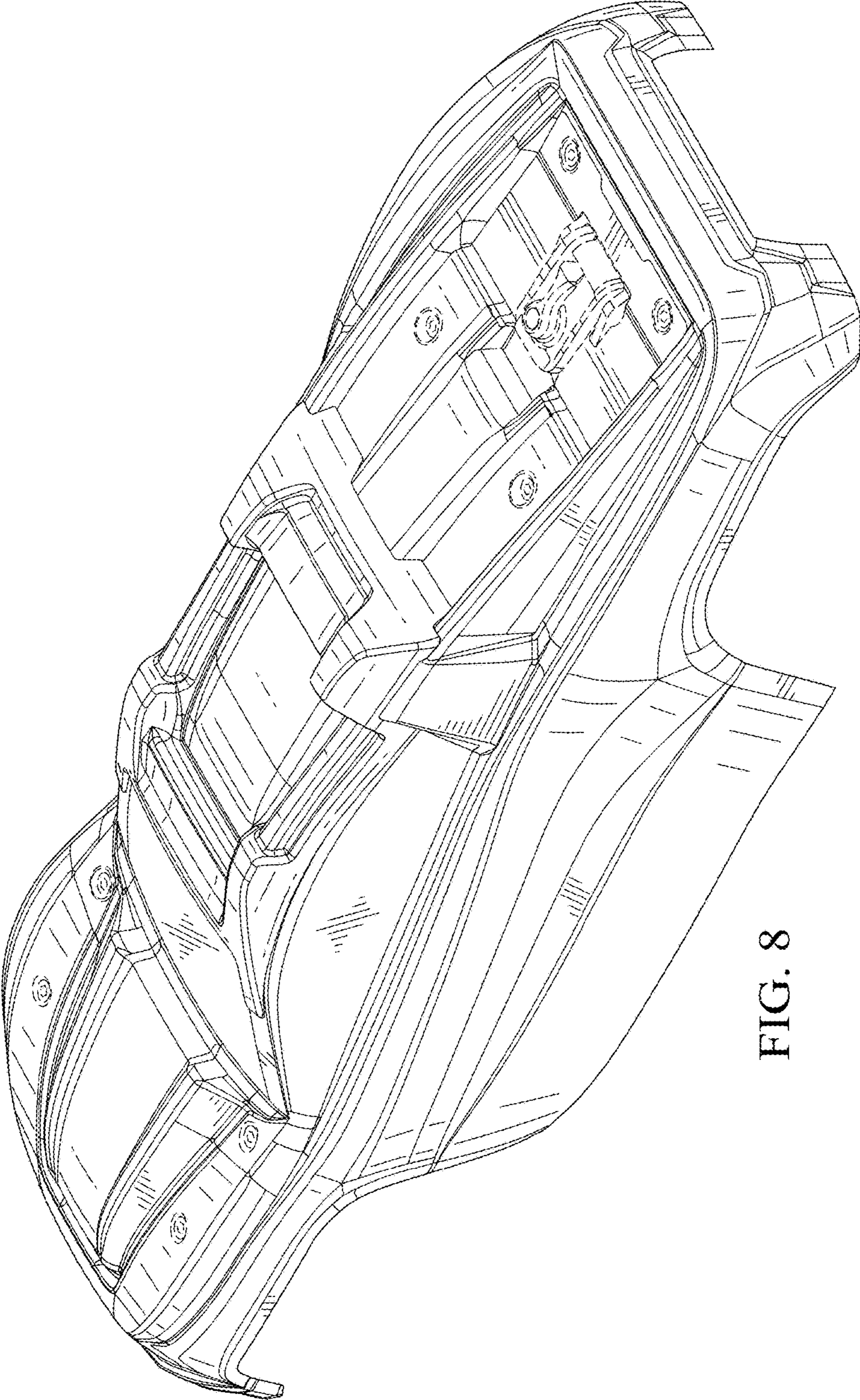

FIG. 8

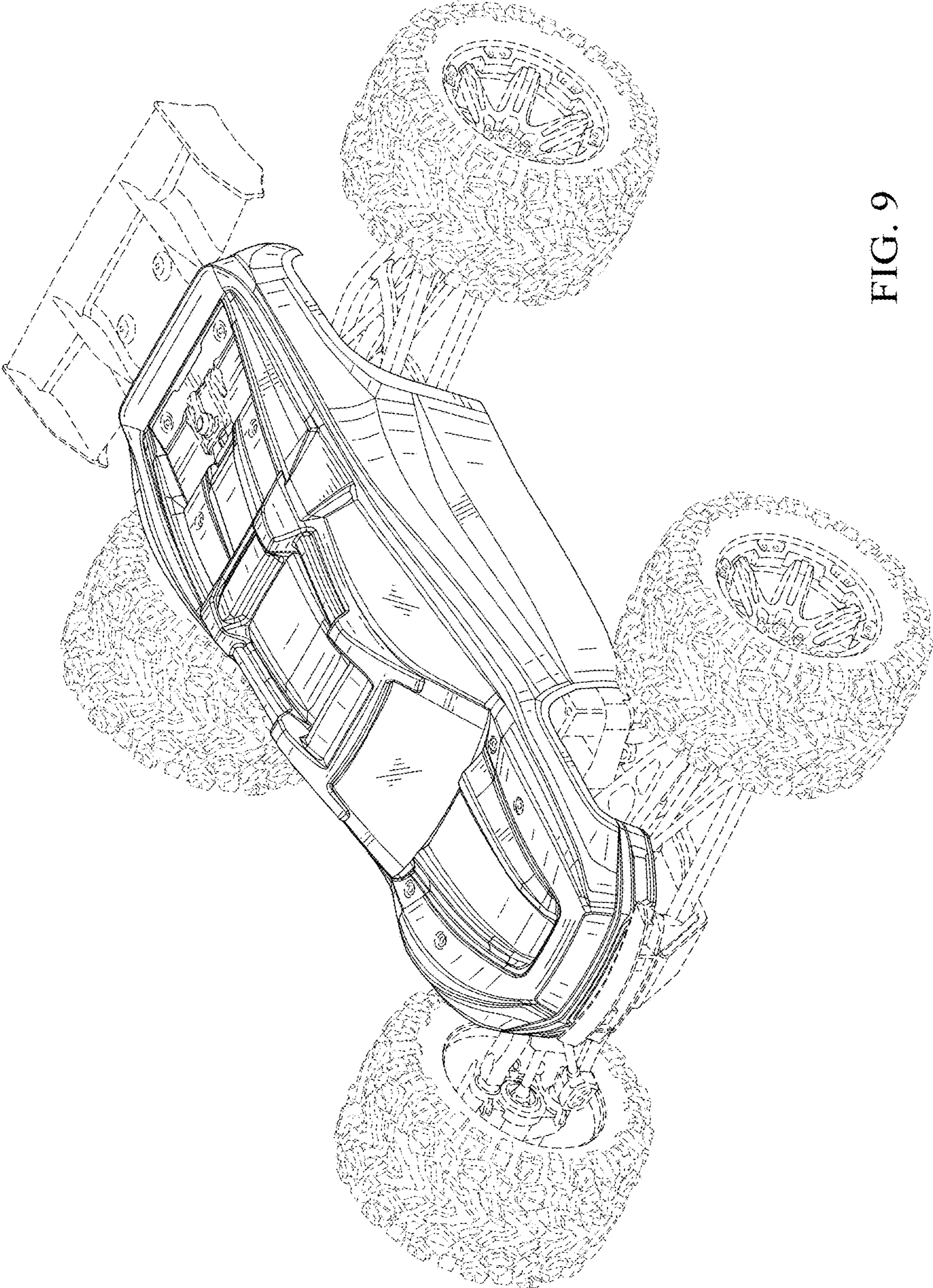

FIG. 9